



UNIVERSITY OF
PLYMOUTH



School of Engineering, Computing and Mathematics Theses
Faculty of Science and Engineering Theses

1998

A soft systems approach to the formulation of a manufacturing strategy

Tammy Jane Greswell

Let us know how access to this document benefits you

General rights

All content in PEARL is protected by copyright law. Author manuscripts are made available in accordance with publisher policies. Please cite only the published version using the details provided on the item record or document. In the absence of an open licence (e.g. Creative Commons), permissions for further reuse of content should be sought from the publisher or author.

Take down policy

If you believe that this document breaches copyright please [contact the library](#) providing details, and we will remove access to the work immediately and investigate your claim.

Follow this and additional works at: <https://pearl.plymouth.ac.uk/secam-theses>

Recommended Citation

Greswell, T. (1998) *A soft systems approach to the formulation of a manufacturing strategy*. Thesis. University of Plymouth. Retrieved from <https://pearl.plymouth.ac.uk/secam-theses/490>

This Thesis is brought to you for free and open access by the Faculty of Science and Engineering Theses at PEARL. It has been accepted for inclusion in School of Engineering, Computing and Mathematics Theses by an authorized administrator of PEARL. For more information, please contact openresearch@plymouth.ac.uk.



UNIVERSITY OF
PLYMOUTH

PEARL

PHD

A soft systems approach to the formulation of a manufacturing strategy

Greswell, Tammy Jane

Award date:
1998

Awarding institution:
University of Plymouth

[Link to publication in PEARL](#)

All content in PEARL is protected by copyright law.

The author assigns certain rights to the University of Plymouth including the right to make the thesis accessible and discoverable via the British Library's Electronic Thesis Online Service (EThOS) and the University research repository (PEARL), and to undertake activities to migrate, preserve and maintain the medium, format and integrity of the deposited file for future discovery and use.

Copyright and Moral rights arising from original work in this thesis and (where relevant), any accompanying data, rests with the Author unless stated otherwise*.

Re-use of the work is allowed under fair dealing exceptions outlined in the Copyright, Designs and Patents Act 1988 (amended), and the terms of the copyright licence assigned to the thesis by the Author.

In practice, and unless the copyright licence assigned by the author allows for more permissive use, this means,

That any content or accompanying data cannot be extensively quoted, reproduced or changed without the written permission of the author / rights holder

That the work in whole or part may not be sold commercially in any format or medium without the written permission of the author / rights holder

* Any third-party copyright material in this thesis remains the property of the original owner. Such third-party copyright work included in the thesis will be clearly marked and attributed, and the original licence under which it was released will be specified. This material is not covered by the licence or terms assigned to the wider thesis and must be used in accordance with the original licence; or separate permission must be sought from the copyright holder.

**A SOFT SYSTEMS APPROACH TO THE FORMULATION OF A
MANUFACTURING STRATEGY**

By

TAMMY JANE GRESWELL

A thesis submitted to the University of Plymouth
in partial fulfilment of the degree of

DOCTOR OF PHILOSOPHY

School of Computing
Faculty of Technology
In collaboration with British Aerospace PLC

September 1998

Copyright Statement

This copy of the thesis has been supplied on condition that anyone who consults it is understood to recognise that its copyright rests with its author and that no quotation from the thesis and no information derived from it may be published without the author's prior written consent.

Signed.....*Frederick*.....

Date.....*17-11-98*.....

A soft systems approach to the formulation of a manufacturing strategy

Tammy Jane Greswell

September 1998

Abstract

This work investigated the understanding and use of current manufacturing strategy methods within the UK aerospace industry. Several key issues were identified which suggested a need to rethink the process of manufacturing strategy formulation. The set of issues included: the lack of explicit manufacturing strategies by several case organisations, a lack of the general use of developed manufacturing strategy tools and techniques, and a general evolution of organisations from functionally based to a business process focus. These issues suggested that the current approaches to manufacturing strategy were not reaching their target audience practitioners, and that further development of the manufacturing strategy formulation process was necessary to improve the usability and subsequent use of manufacturing strategy concepts.

Taking these issues into account, the research used three cycles of learning using the soft systems methodology to develop a greater understanding of the domain of manufacturing strategy. Cycle One identified the process of manufacturing strategy formulation as a problem situation and used systems concepts and soft systems methods to develop three manufacturing strategy archetypes. These included a customer focussed / market led approach, a best practice approach and a knowledge-based approach to manufacturing strategy. Each archetype was developed using systems concepts by defining a root definition and developing conceptual models in order to make the thinking explicit, systemic, and useful to practitioners. Cycle Two explored the manufacturing strategy formulation processes of aerospace organisations and provided a sound base to identify appropriate changes to current manufacturing strategy methods based on both functionally orientated and business process focussed organisations.

The third cycle developed a modified approach to the formulation of a manufacturing strategy using soft systems concepts, which was incorporated into a workbook format in order to test out the changes identified and learning experienced in the previous cycles. The format and use of the approach were validated using several case organisations, using the criteria that research results should be useful to practitioners within the production and operations management domain.

The contribution of the work comes from the critical evaluation of existing manufacturing strategy methods and techniques, the development of three manufacturing strategy making systems and the development of a modified approach for developing a manufacturing strategy. The evaluation determined that the above were not well enough developed for the evolving aerospace industry. Opportunities for improvement were identified which were incorporated into an improved method for formulating a manufacturing strategy. The method makes use of three manufacturing strategy archetypes, developed using systems theory to ensure the thinking surrounding manufacturing strategy is made explicit and systemic. The approach is based around Checklands' (1990) soft systems methodology and each iteration of the methodology should be seen as a cycle of learning.

TABLE OF CONTENTS

COPYRIGHT STATEMENT	1
ABSTRACT	3
TABLE OF CONTENTS.....	4
LIST OF TABLES.....	12
LIST OF FIGURES.....	13
ACKNOWLEDGEMENTS.....	14
AUTHOR’S DECLARATION.....	15
1 CHAPTER ONE – INTRODUCTION.....	17
1.1 Background	17
1.2 Evolution of the research	20
1.3 The research questions.....	22
1.4 Objectives	23
1.5 The development of principles and key concepts.....	24
1.6 Contribution.....	28
1.7 Thesis structure.....	30
1.8 Summary	31
2 CHAPTER TWO - THE CHALLENGES FACING THE UK AEROSPACE INDUSTRY	32
2.1 Evolution of the UK aerospace industry	32
2.2 The global environment and effects on competition.	35
2.3 Key issues facing the industry.....	36
2.4 The role of manufacturing and manufacturing strategy	39
3 CHAPTER THREE - MANUFACTURING STRATEGY.....	41

3.1	An introduction to strategy.....	41
3.2	Hierarchies of Strategy	42
3.3	Manufacturing strategy	43
3.4	The manufacturing strategy research domain.....	44
3.5	The benefits of researching manufacturing strategy	45
3.6	Researching manufacturing strategy.....	45
3.7	Manufacturing Strategy – Content and Process.....	47
3.7.1	Manufacturing Strategy – Content	47
3.7.2	Manufacturing Strategy – Process.....	50
3.7.2.1	Point of Entry	50
3.7.2.2	Participation	52
3.7.2.3	Procedure	52
3.7.2.4	Project Management	53
3.8	Frameworks used to describe manufacturing strategy.....	53
3.9	Three manufacturing strategy archetypes	56
3.9.1	The market led / customer focussed approach to manufacturing strategy.....	58
3.9.1.1	Evolution.....	58
3.9.1.2	Content of market led / customer focussed archetype.....	58
3.9.1.3	Process of the market led / customer focussed archetype.....	59
3.9.1.4	Summary of market led / customer focussed archetype for manufacturing strategy	61
3.9.2	The ‘best practice’ approach to manufacturing strategy	62
3.9.2.1	Evolution.....	62
3.9.2.2	Content of the best practice archetype.....	62
3.9.2.3	Process of the best practice manufacturing strategy archetype.....	64
3.9.2.4	Summary of the best practice archetype for manufacturing strategy	66
3.9.3	The knowledge-based approach to manufacturing strategy	67
3.9.3.1	Evolution.....	67
3.9.3.2	Content of the knowledge-based archetype	67
3.9.3.3	Process of the knowledge-based archetype for Manufacturing Strategy.....	69
3.9.3.4	Summary of the knowledge-based approach to manufacturing strategy	72
3.10	Summary of manufacturing strategy archetypes.....	72
3.11	The hard systems approach to manufacturing strategy	74
3.12	Discussion	75
4	CHAPTER FOUR - EMPIRICAL ANALYSIS (PHASE ONE).....	76
4.1	Introduction.....	76
4.2	Initial case study framework	77
4.3	Case study research plan	78

4.4	Conducting the case studies	79
4.5	Initial case Studies.....	79
4.5.1	Themes.....	79
4.5.2	Summary of the initial case studies.....	80
4.5.2.1	Case A.....	80
4.5.2.2	Case B.....	81
4.5.2.3	Case C.....	82
4.5.3	Analysis of initial case studies	83
4.5.3.1	The key issues	83
4.5.3.2	The manufacturing strategy process	83
4.5.3.3	Point of entry.....	83
4.5.3.4	Participation– who participated in the process within the organisation	84
4.5.3.5	Archetypes	84
4.5.3.6	Change programmes	84
4.5.3.7	Hard systems approach	84
4.5.4	Inferences and findings from cases	85
4.5.5	Summary of case study results.....	86
5	CHAPTER FIVE - RESEARCH METHODOLOGY.....	88
5.1	Objectives of chapter	88
5.2	The objective of the research	88
5.3	Evolution of the research methodology	89
5.3.1	The Research Cycle.....	90
5.3.2	The needs of the Production and Operations Management practitioner	92
5.3.3	Research methods and strategies.....	95
5.3.4	Case studies as a research tool	97
5.4	Research requirements for the POM practitioner.....	98
5.5	The research methodology used in this research programme.....	99
5.5.1	Phase One.....	100
5.5.1.1	Description (problem definition).....	101
5.5.1.2	Explanation (conceptualisation).....	101
5.5.1.3	Testing (validation).....	101
5.5.1.4	Summary of Phase One.....	102
5.5.2	Phase Two.....	102
5.6	Discussion	103
6	CHAPTER SIX - SYSTEMS THEORY AND THE BUSINESS PROCESS PARADIGM	105
6.1	Introduction.....	105
6.2	Systems thinking	106
6.3	Evolution of systems thinking.....	106
6.4	The nature of systems thinking.....	107
6.4.1	Hard Systems Thinking (HST)	111

6.4.2	Soft Systems Thinking (SST)	112
6.5	Soft systems thinking and manufacturing strategy formulation research.....	121
6.6	Business Processes and Business Process re-engineering	123
6.6.1	The business process paradigm and systems theory	124
6.7	Discussion	125
6.8	Conclusion	127
7	CHAPTER SEVEN - DEVELOPMENT OF A MARKET LED / CUSTOMER FOCUSED MANUFACTURING STRATEGY-MAKING SYSTEM	128
7.1	Introduction.....	128
7.2	The approach.....	128
7.3	Systems Parameters and Concepts which are omitted from the definition and development of the three manufacturing strategy-making systems	129
7.3.1	Customers	130
7.3.2	Mechanisms	130
7.3.3	Environment.....	130
7.3.4	Owner	130
7.4	Development of a rich picture for a customer focussed / market led manufacturing strategy-making system.....	131
7.5	Development of the root definition	133
7.5.1	Actors	133
7.5.2	Transformation.....	134
7.5.3	Weltanschauung / world view.....	134
7.6	Development of the system parameters.....	134
7.6.1	Sources.....	134
7.6.2	Inputs	135
7.6.3	Process	135
7.6.4	Outputs.....	135
7.6.5	Feedback.....	136
7.7	The Conceptual model	136
7.8	Summary	139
8	CHAPTER EIGHT - DEVELOPMENT OF A BEST PRACTICE MANUFACTURING STRATEGY-MAKING SYSTEM.....	140
8.1	The development of a rich picture for a best practice manufacturing strategy-making system.....	140
8.2	Development of the root definition.....	142
8.2.1	Actors	142
8.2.2	Transformation.....	143
8.2.3	Weltanschauung / world view.....	143

8.3	Development of the system parameters.....	143
8.3.1	Sources.....	143
8.3.2	Inputs.....	143
8.3.3	Process.....	144
8.3.4	Outputs.....	144
8.3.5	Feedback.....	145
8.4	The Conceptual model.....	145
8.5	Summary.....	149
9	CHAPTER NINE - DEVELOPMENT OF A KNOWLEDGE-BASED MANUFACTURING STRATEGY-MAKING SYSTEM AND COMPARISON OF THE THREE MANUFACTURING STRATEGY MAKING SYSTEMS.....	150
9.1	The development of a rich picture for a knowledge-based manufacturing strategy-making system.....	150
9.2	Development of the root definition.....	152
9.2.1	Actors.....	152
9.2.2	Transformation.....	153
9.2.3	Weltanschauung / world view.....	153
9.3	Development of the system parameters.....	153
9.3.1	Sources.....	153
9.3.2	Inputs.....	153
9.3.3	Process.....	154
9.3.4	Outputs.....	154
9.3.5	Feedback.....	154
9.4	The conceptual model.....	155
9.5	Discussion.....	158
9.6	Summary of the three manufacturing strategy-making systems.....	158
10	CHAPTER TEN - EMPIRICAL ANALYSIS - PHASE TWO.....	162
10.1	Introduction.....	162
10.2	Phase Two.....	163
10.3	Summary of the empirical cases for phase two.....	164
10.3.1	Case D.....	164
10.3.2	Case E.....	165
10.3.3	Case F.....	166
10.3.4	Case G.....	169
10.3.5	Case H.....	171
10.3.6	Case I.....	173
10.3.7	Case J.....	175
10.4	Cycle Two of the Soft System Methodology.....	177
10.4.1	Stage one - the problem situation:.....	178
10.4.2	Stage Two - identification of systems relevant to the problem situation.....	179

10.4.3	Stage Three and Four - development of root definitions and conceptual models for each case	181
10.4.4	Stage Five – analysis of cases	182
10.4.4.1	Comparison of the themes between the empirical cases (case with case analysis)	182
10.4.4.2	Inferences from findings from case to case analysis	184
10.4.4.3	Comparison of cases with the rich picture	185
10.4.4.4	Inferences from findings of cases to rich picture analysis	186
10.4.4.5	Comparison of cases with three manufacturing strategy-making systems ..	186
10.4.4.5.1	Market led / customer manufacturing strategy-making system	186
10.4.4.5.2	Best practice manufacturing strategy-making system	186
10.4.4.5.3	Knowledge-based manufacturing strategy-making system	187
10.4.4.5.4	A hybrid	187
10.4.4.6	Inferences from findings of the cases and the manufacturing strategy-making systems.....	188
10.4.4.7	Summary of key findings and results	189
10.4.5	Stage Six - identification of feasible and systemically desirable changes to current manufacturing strategy-making systems.....	191
10.4.6	Implications of using a soft systems approach to develop a manufacturing strategy	193
10.4.6.1	Market led / customer focussed approach to manufacturing strategy ...	193
10.4.6.2	Best practice approach to manufacturing strategy.....	193
10.4.6.3	Knowledge-based manufacturing strategy approach.....	194
10.5	Discussion	194
11	CHAPTER ELEVEN - DEVELOPMENT OF ‘A MODIFIED APPROACH TO THE FORMULATION OF A MANUFACTURING STRATEGY’ USING SYSTEMS THINKING (CYCLE THREE).....	196
11.1	Objectives	196
11.2	The need for a modified manufacturing strategy approach	197
11.2.1	The literature.....	197
11.2.2	The UK aerospace industry.....	198
11.2.3	The empirical cases	198
11.2.4	The practitioners.....	199
11.3	Summary of requirements for a manufacturing strategy making process	199
11.4	The development of the approach.....	200
11.5	The Approach.....	201
11.5.1	Stage One – does the organisation see the need for change?.....	202
11.5.2	Stage Two – the manufacturing organisation and its effect on the competitiveness of the organisation.....	202
11.5.3	Stage Three – the problem situation – development of the manufacturing strategy	202
11.5.4	Stage Four – development of the root definitions for each relevant system..	203
11.5.5	Stage Five – development of conceptual models.....	203
11.5.6	Stage Six – comparison of the conceptual models with the real world situation.	204

11.5.7	Stage Seven – identification of feasible changes delivered as an action plan. 204	
11.5.8	Notes for implementation	204
11.6	Delivery	204
11.7	The workbook.....	206
11.7.1	Section One – the theoretical base	206
11.7.2	Section Two – the soft systems approach to manufacturing strategy	207
11.7.2.1	Stage One – does the organisation see the need for change?	207
11.7.2.2	Stage Two – The manufacturing organisation and its effect on the competitiveness of the organisation (the real world problem situation – unstructured)..	208
11.7.2.3	Stage Three – The problem situation – the development of the manufacturing strategy? – what do we want manufacturing to achieve and how do we want the relevant systems to support it?.....	208
11.7.2.4	Stage Four – the development of the root definition for each relevant system selected in stage three.....	209
11.7.2.5	Stage Five – the development of conceptual models derived from the root definitions from each relevant system.....	209
11.7.2.6	Stage Six – Comparison of the conceptual models to the real world situation	210
11.7.2.7	Stage Seven – identification of feasible and desirable changes to the manufacturing strategy system – output – the direction of the manufacturing system – the manufacturing strategy	210
11.7.3	Section Three – Additional information.....	210
11.7.4	Section Four – feedback of approach	211
11.7.5	Section Five – process model of the approach.....	211
11.8	Validation of the approach.....	211
11.8.1	Validation through use.....	212
11.8.1.1	Case L	212
11.8.1.2	Case M	213
11.8.1.3	Case N.....	214
11.8.2	Validation through debate.....	215
11.9	Future development of the approach.....	215
11.10	Discussion	216
12	CHAPTER TWELVE – DISCUSSION AND CONCLUSIONS.....	217
12.1	Introduction.....	217
12.2	Research problem.....	218
12.3	Research methodology	219
12.4	Exploratory research.....	220
12.5	The development of three manufacturing strategy-making systems.....	221
12.6	The empirical evidence.....	222

12.7	The need for a modified approach to the formulation of a manufacturing strategy	223
12.8	Manufacturing strategy requirements for UK aerospace organisations....	223
12.9	Validation of the approach.....	225
12.10	The contribution.....	225
12.11	Future research	227
REFERENCES		228
APPENDICES		242
APPENDIX ONE.....		244
APPENDIX TWO.....		245
APPENDIX THREE – MODIFIED APPROACH TO THE FORMULATION OF A MANUFACTURING STRATEGY.....		246
APPENDIX FOUR – VALIDATION OF THE MODIFIED APPROACH TO THE FORMULATION OF A MANUFACTURING STRATEGY.....		247
PUBLICATIONS.....		248

List of Tables

Table 1.	Manufacturing strategy decision areas by Hayes and Wheelwright	Chapter 3
Table 2.	Summary of initial case study research findings	Chapter 4
Table 3.	Summary of soft systems thinking research approach	Chapter 6
Table 4.	Summary of approach for Chapters 7 8 and 9	Chapter 6
Table 5.	Summary of parameters for the market led customer focussed manufacturing strategy-making system	Chapter 7
Table 6.	Summary of parameters for a best practice manufacturing strategy making systems	Chapter 8
Table 7.	Summary of parameters for a knowledge-based manufacturing strategy-making system	Chapter 9
Table 8.	Summary of manufacturing strategy archetypes	Chapter 9
Table 9.	Summary of approach for Chapter Ten	Chapter 10
Table 10.	Case study research methods summary	Chapter 10
Table 11.	Root definitions for each case study	Chapter 10

LIST OF FIGURES

Figure	1.	Thesis structure	Chapter 1
Figure	2.	The structure of the UK aerospace industry	Chapter 2
Figure	3.	The SBAC competitiveness challenge	Chapter 2
Figure	4.	Competitive profiles (Platts and Gregory, 1989)	Chapter 3
Figure	5.	Manufacturing strategy framework (Mills et al, 1995)	Chapter 3
Figure	6.	Closed loop deployment and feedback systems to the performance measurement process	Chapter 3
Figure	7.	Model of best practice framework	Chapter 3
Figure	8.	Capability process model	Chapter 3
Figure	9.	Manufacturing strategy archetype framework	Chapter 3
Figure	10.	Meredith's research cycle	Chapter 5
Figure	11.	Phase One – Research Cycle	Chapter 5
Figure	12.	Phase Two – Research Cycle	Chapter 5
Figure	13.	Systems parameters	Chapter 6
Figure	14.	The Stream of logic based analysis in SSM	Chapter 6
Figure	15.	Rich picture of critical success factors for the UK aerospace industry	Chapter 6
Figure	16.	A conceptual model of a manufacturing strategy process	Chapter 6
Figure	17.	The stream of cultural analysis in SSM	Chapter 6
Figure	18.	A rich picture for the market led / customer focussed approach to manufacturing strategy	Chapter 7
Figure	19.	IDEFo conceptual model for the market led / customer focussed manufacturing strategy-making system	Chapter 7
Figure	20.	A rich picture for the best practice approach to manufacturing strategy	Chapter 8
Figure	21.	IDEFo conceptual model for the best practice approach manufacturing strategy-making system	Chapter 8
Figure	22.	A rich picture for the knowledge-based approach to manufacturing strategy	Chapter 9
Figure	23.	IDEFo conceptual model for the knowledge-based manufacturing strategy-making system	Chapter 9
Figure	24.	Rich picture for case F	Chapter 10
Figure	25.	Road map for the modified approach to the formulation of a manufacturing strategy	Chapter 11

Acknowledgements

I would like to express my thanks to Bablu, Mum and Dad and all the people who have supported and encouraged me during my years at Plymouth and at BAe.

A special thank-you to Dr Stephen Childe and Dr Roger Maull for all your insights and comments! And also to the Manufacturing and Business Systems Group at the University of Plymouth - especially Jim O'Brien who supported me through 3 years with numerous cups of tea. Not forgetting Miss Zoe Nash, Miss Cita Wood, Dr Andi Smart, Dr Jan Bennett, Mr. Tom Rogers, Mr. John Bradford, Mrs Donna Sanders and Mrs. Debbie Boyne for their support!

The work was supported with facilities provided by Professor Patricia Pearce, Head of the School of Computing, University of Plymouth and by the Engineering and Physical Sciences Research Council. I would also like to express my thanks to British Aerospace Plc for providing me with a three -year career break in which to carry out my PhD, especially Christene Macbeth, Kevin Wadsworth and Callum Menzies.

Author's declaration

At no time during the registration for the degree of Doctor of Philosophy has the author been registered for any other University award.

The research was undertaken while the author was employed as a research student funded by the Engineering and Physical Sciences Research Council (EPSRC) whilst on a career break from British Aerospace Plc. The research described in this thesis was the result of work undertaken by the author.

The publications that have been produced during the research are presented at the end of the thesis. These are:

Greswell T, Childe S J, Maull R S, Bennett J, (1995) 'A Two fold approach to manufacturing improvement', *Proceedings of the 12th Conference of the Irish Manufacturing Committee*, 6-8th September, University College Cork, pp. 429-436

Greswell T, Childe S J, Maull R S, Bennett J (1995), 'Linking manufacturing strategy to process improvement', *Advances in Manufacturing Technology IX, Proceedings of the 11th National Conference on Manufacturing Research* 12-14 September, De-Montfort University Leicester, pp 656-60

Greswell T, Childe S J, Maull R S, Bennett J, Campbell N (1995) 'The role of manufacturing strategy within a Business Process Re-engineering change programme', *Proceedings of the 13th International Conference on Production Research*, Jerusalem, Israel 6-10 August, pp 144-146

Greswell T, Maull R, Childe S, Bennett J (1996) 'The linking of manufacturing strategy to business process re-engineering', *Proceedings of the 3rd International Conference of the European Operations Management Association*, 2-4 June, London.

Greswell T, Childe S, Maull R, Nash Z (1998) 'A soft systems approach to the formulation of a manufacturing strategy' *Operations management future issues and competitive responses Proceedings of the 5th International Conference of the European Operations Management Association*, Dublin, Eire 14-17 June

Greswell T, Childe S, Maull R (1998) 'Three manufacturing strategy archetypes – a framework for the aerospace industry' *Proceedings of the IFIP WG 5.7 Working conference Strategic management of the manufacturing value chain* 26 – 28 August University of Strathclyde

Greswell T, Childe S, Maull R, Smart P A (1998) 'The development of three manufacturing strategy-making systems' *Proceedings of the 3rd International conference – Managing Innovative Manufacturing (MIM'98)* University of Nottingham 6 – 8 July

The following conferences and presentations were attended during the research period:

- Oct 94
- Visit to Pilkington Glass
 - MBA Quality Presentation on Quality Systems

- Nov 94*
 - Visit to Dresser Rand ref. BPR
 - Visit to TripleX - part of Pilkington Glass
- Feb 95*
 - Research Methodology Workshop at Cambridge University - Churchill College - presented initial research ideas
 - Visit to Barclays Bank
 - Visit to Royal Mail
- Apr 95*
 - BPR Course at Plymouth University
- June 95*
 - BPR Course at Plymouth University
 - Management of Innovation Conference at Aston
- Sept 95*
 - IMC Conference at Cork Ireland presented conference paper
 - NCMR Conference at De Montfort University presented conference paper
- Oct 95*
 - Speed Reading Workshop
- Jan 96*
 - West of England Aerospace Forum meeting: contacts in local industry
- Mar 96*
 - Research Methodology Workshop at Cambridge University - Churchill College - Invited to speak
- May 96*
 - Case A visits
 - Case C visits
 - Case E visits
 - Writing Academic Papers – Workshop Dartington Hall
- June 96*
 - Euroma Conference Stakis St Ermins Hotel London: presented conference paper
- July 96*
 - EPSRC Graduate School at Sheffield
- Oct 96*
 - Graduate Teaching Assistants Course
- Nov 96*
 - Graduate Teaching Assistants Course
 - Collaboration with Cranfield on Manufacturing Strategy
- Dec 96*
 - Graduate Teaching Assistants Course
 - Teaching Manufacturing Strategy Course at London Business School with Terry Hill
- Jan 97*
 - Graduate Teaching Assistants Course
- Mar 97*
 - Manufacturing and Business Systems Group Research workshop
 - Mind Mapping Workshop
- Apr 97*
 - 2 week placement at Case F – initial contact with Project Team and the use of SSM in developing their strategy, and the head of BPR, Operations Development
 - Mind mapping workshop
 - Dave Tranfield - TQM framework and archetypes lecture
- May 97*
 - Manufacturing and Business Systems Group Research meeting
- July 97*
 - 9th Workshop for validation of Soft Systems Approach to the Formulation of a Manufacturing Strategy
 - Proposal developed for SSM and the Eurofighter Manufacturing Strategy
- Aug 97*
 - SSM Course with Peter Checkland at University of Central Lancashire
- Oct 97 – April 98*
 - Employed as a manufacturing engineer at BAe MA&A Samlesbury
- April 98 - date*
 - Employed as a research assistant at the University of Plymouth

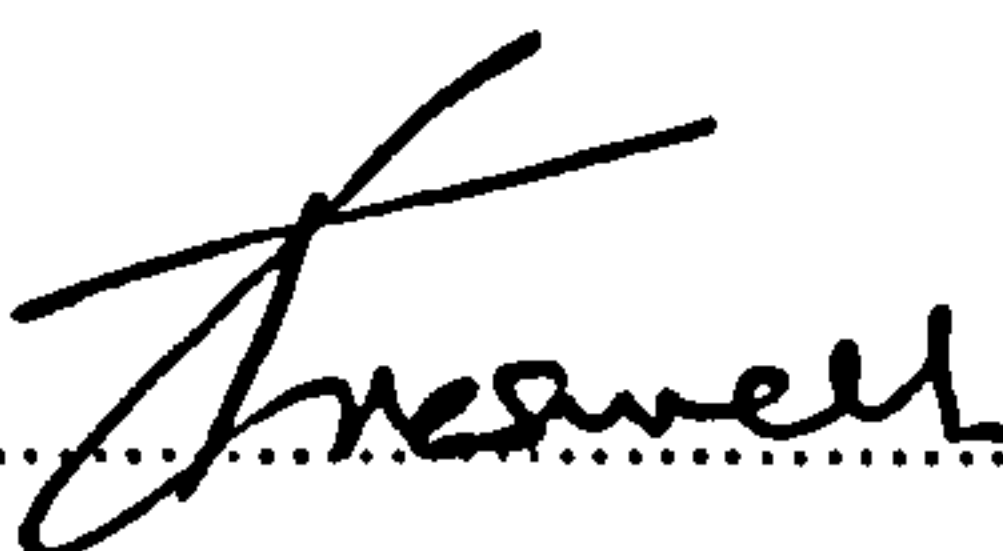
Signed..........

Date.....*2nd Sept '98*.....

1 Chapter One – Introduction

The research described in this thesis was carried out by the author as a research student at the University of Plymouth whilst on a career break and in collaboration with British Aerospace Military Aircraft and Aerostructures Ltd. The research was supported by the Engineering and Physical Sciences Research Council (EPSRC), the Manufacturing and Business Systems Research Group (MABS) and the School of Computing at the University of Plymouth.

This chapter has the following objectives: To introduce and describe the evolution of the research project entitled ‘A soft systems approach to the formulation of a manufacturing strategy’. This will set the scene for the thesis by introducing the research question set and subsequent objectives, and the research domain. The research domain will be described by presenting the key concepts which underpin the research. The key concepts include the challenges facing the UK aerospace industry, manufacturing strategy, the business process paradigm and systems thinking. The chapter concludes with a description of the thesis structure.

1.1 Background

‘Strategy problems are complex. To resolve them a company needs first, concepts to give insights and to help choose between outcomes, second, a recognition that it is a problem requiring an intellectual resolution and, third, a willingness to work hard’ Terry Hill (1994)

The research project ‘A soft systems approach to the formulation of a manufacturing strategy’ is the result of a three -year EPSRC research studentship. The work initially investigated and questioned the manufacturing operation’s role in improving the competitiveness of the UK aerospace industry. This identified the area of

manufacturing strategy as a useful and powerful tool to enhance the competitiveness of the UK aerospace industry through its manufacturing capability.

Skinner (1969) identified manufacturing strategy as an invaluable asset in developing the competitiveness of an organisation. His paper described the use of manufacturing as a competitive weapon, which can support or shape corporate and business strategy. In the current dynamic competitive environment, it is critical to ensure manufacturing is capable of supporting the business strategy and to develop manufacturing capabilities that will enable the organisation to remain competitive.

Several streams have emerged over the past decade, which are providing researchers with real opportunities to provide the practitioner with useful and powerful concepts and techniques to enable them to develop manufacturing as a competitive weapon. These streams have been described by Whittle et al (1994) as the market led / customer focussed approach, the best practice approach and the knowledge-based approach to manufacturing strategy.

The market led / customer focussed approach focuses on the order winners and order qualifiers of products and services. The approach is well developed and is grounded in empirical research by researchers such as Hill (1985), Buffa (1984), De Meyer (1996), Filippini (1997), Anderson et al (1991), Schroeder et al (1991), Hum and Leow (1996), Platts (1995), and Hayes and Wheelwright (1984). The essence of the approach is to achieve competitive advantage by satisfying the customers' needs. The approach focuses on the identification of order winners and order qualifiers and the alignment of the manufacturing systems to those order winners and qualifiers of the product. The approach incorporates the view that trade offs will be required within the system, that is, a focus is required which is supported by the work of Skinner (1974).

The best practice approach is efficiency-based and has evolved from viewing the phenomenal success of Japanese organisations. The Toyota Production System (Ohno, 1988) has had a profound effect on the development and evolution of the best practice

approach. The approach has evolved incorporating a plethora of philosophies which western organisations have adopted to try to match the operational effectiveness of the Japanese. Schonberger (1982, 1986, and 1996) has developed the world class manufacturing approach and this 'label' has been adopted by many organisations wanting to emulate their competitors.

The best practice approach is characterised by the large number of change programmes, which encapsulate philosophies such as:

- Business Process Re-engineering (BPR) (Childe et al 1996, Koch et al, 1997),
- Benchmarking (Armistead et al, 1995),
- Total Quality Management (TQM),
- World Class Manufacturing (Schonberger, 1996) and Lean Operations (Womack et al, 1990).

The approach uses benchmarking and performance measures as the enablers to drive through change and to identify changes required (Neely et al, 1994).

The knowledge-based approach has evolved from the stance that it is unlikely that an organisation can achieve sustained competitive advantage by only emulating best practice as described by Hayes and Pisano (1994). The approach holds the view that an organisation should focus on the development of core competencies within their processes, people, and technology to enable the development of new markets and directions (Prahalad and Hamel, 1990). These core competencies must be difficult to replicate in order to sustain competitive advantage (Hayes and Pisano 1994, Teece, Pisano and Shuen 1997, Knott et al 1996, Nonaka 1991). The approach focuses on the resources and assets required for learning and the development of these competencies and capabilities. Hayes and Pisano (1994) have reintroduced the knowledge-based approach to manufacturing strategy research.

The work of Teece et al (1997) and Senge (1990) who developed the concept of 'The Fifth Discipline' also strengthens this view of manufacturing strategy from the work done to develop the domain of core competencies and systems thinking in organisations.

The concept of the learning organisation had been developed earlier by Argyris and Schon (1978). The approach has been receiving a surge in interest with authors such as Lewis and Gregory (1993), Cleveland et al (1989), and Fine and Whitney (1996) making contributions to the area.

The three approaches are not mutually exclusive and organisations will not necessarily focus on one approach and disregard the others. It has been useful to describe the manufacturing strategy domain in this way to bound and clarify the different aspects associated within the field.

The aerospace industry has changed dramatically to respond to globalisation of the market and competitive changes which have occurred over the past decade (Bishop, 1997). To ensure that the remaining aerospace organisations survive, it is crucial that the operations practitioners utilise the powerful concepts that manufacturing strategy provides (Hesford, 1997). It is therefore also critical to ensure that manufacturing strategy develops to tackle the challenges that evolve with them. It is important that the production and operation management practitioners are provided with a set of concepts, tools and techniques which can assist them in the demanding task of formulating and implementing a manufacturing strategy which is applicable to their needs (Thomas and Tymon, 1982).

1.2 Evolution of the research

Three initial case studies were developed following the identification of manufacturing strategy as a powerful concept in the role of enhancing the competitiveness of the UK aerospace industry. The case studies A, B and C can be found in Appendix One. These case studies explored the use and understanding of manufacturing strategy methods

within the industry. The cases identified several issues that were considered worthy of additional analysis and helped to shape the research question set and subsequent research direction.

The aerospace market has changed dramatically due to several factors. The market has become increasingly more competitive whilst shrinking due to changes in defence policy and a fall then a rise in commercial traffic (Smith D J, 1997). The ending of the cold war changed the way procurement agencies place orders and the size of orders placed. This may be due to the perceived threat of aggression diminishing and the procurement agencies having to justify their expenditure more vigorously (Bishop, 1997). However the major implication for the defence industry is the move from 'cost plus' to 'fixed price' contracts (Roe, 1997).

The move from 'cost plus' to 'fixed price' has had a profound effect on the supply chain from the prime contractors through to the systems integrators, systems suppliers and component suppliers, which is evident from the massive restructuring programmes that have occurred in the industry. More details can be found in cases A, B and C in Appendix One. The industry had to focus on becoming more efficient and competitive in their operations if they were to compete in the global market place (Papin and Kleiner, 1998). Manufacturing strategy was identified as a powerful tool that could and should be used in ensuring the industry is well placed to face the global challenge (Roe, 1997).

The structures of both the industry and of individual organisations continue to change dramatically. The functional organisations which have evolved over the past century from Taylor's (1911) principles, may no longer be appropriate for the dynamic global business environment of the current UK aerospace industry, an environment where lead times, cost and effectiveness in manufacturing are crucial in winning new business (SBAC, 1998). Organisations are still predominantly arranged with the segmentation of work into specialised functions and tasks. However the organisational development paradigm appears to be shifting towards business process focussed organisations (Maull et al 1995).

These organisations are breaking down functional barriers and are creating an organisational architecture of business processes as opposed to functions.

The implication of this change in organisational architecture, is the shift of focus towards the integration and evolution of the organisation as a whole. This may mean that taking a systemic view of the organisation, as opposed to a reductionist, functional view will be useful (Kay and Bawden, 1996). Process teams will need to align their business processes with the business and corporate strategy and may benefit from the exposure of different points of view (Weltanschauungs) due to the different cultures which have evolved in specialist disciplines. This issue was illustrated in Case A. This will be important to ensure that barriers to implementation of any manufacturing strategy are identified and dealt with in the formulation stage of the manufacturing strategy process. The impressions of these changes in the aerospace industry were confirmed by the initial cases which will be discussed in Chapter Four.

1.3 The research questions

The considerations described in section 1.2 are described fully in Chapters Two, Three and Four and helped to form the research questions and the subsequent objectives, which evolved from them.

These are the research questions:

1. Are manufacturing strategy methods and techniques currently used within the UK aerospace industry?
2. Are current manufacturing strategy methods and techniques adequate for use within the changing UK aerospace industry? (bearing in mind the change in focus from functions to business processes)

3. Are there opportunities for developing the current manufacturing strategy methods to support the evolution of UK aerospace organisations from functional orientation to a systemic view?

The following objectives were developed from the research questions set to direct and focus the research.

1.4 Objectives

1. To critically review current manufacturing strategy literature.
2. To determine if manufacturing strategy methods and techniques are currently used within the UK aerospace industry.
3. To identify opportunities for improvement to current manufacturing strategy methods.
4. To develop a tool to address any findings and problems derived from the previous objectives to be useful to the UK aerospace practitioner.

The research objectives were critically evaluated to determine which research domain would best address the research question. The production and operations management (POM) domain was identified as being the most appropriate research area of description and is concerned with the ‘integration of procedures, processes, operating decisions, company policies and technologies to maximise the competitiveness of the organisation’ (Voss, 1984). This puts manufacturing strategy at the heart of the POM domain, as the outcome of the manufacturing strategy formulation process is the journey and direction of the manufacturing organisation. However the contribution may be beneficial to other sectors of industry, as indicated by the validation comments received and which are included in Appendix Four.

The research methodology used within the research programme evolved using Meredith et al's (1989) research cycle of description, explanation and testing and Checkland and Scholes' (1990) 'Soft Systems Methodology'. Meredith's (1989) cycle was used in all phases of the research, but was initially used to develop the literature review and to produce initial findings to move the research forward. Checkland's soft systems methodology was used to develop the research in three cycles of learning using systems concepts. These cycles will be explained and used to develop the research output in Chapters Seven to Eleven.

1.5 The development of principles and key concepts

The following concepts were identified as key to the research.

- The challenges facing the aerospace industry and the role of manufacturing in meeting those challenges are dealt with in Chapter Two.
- The content and process of manufacturing strategy is examined in Chapter Three.
- Systems theory and the business process paradigm are considered in Chapter Six.
- The use of the Soft Systems Methodology (Checkland and Scholes, 1990) as a tool to learn about manufacturing strategy and to identify systemically desirable and feasible modifications to current methods is presented in Chapters Seven to Eleven.
- The use of case study research to develop the empirical data described in Chapters Four, Five, and Ten.

The development of key principles is illustrated in figure 1 which shows the thesis structure.

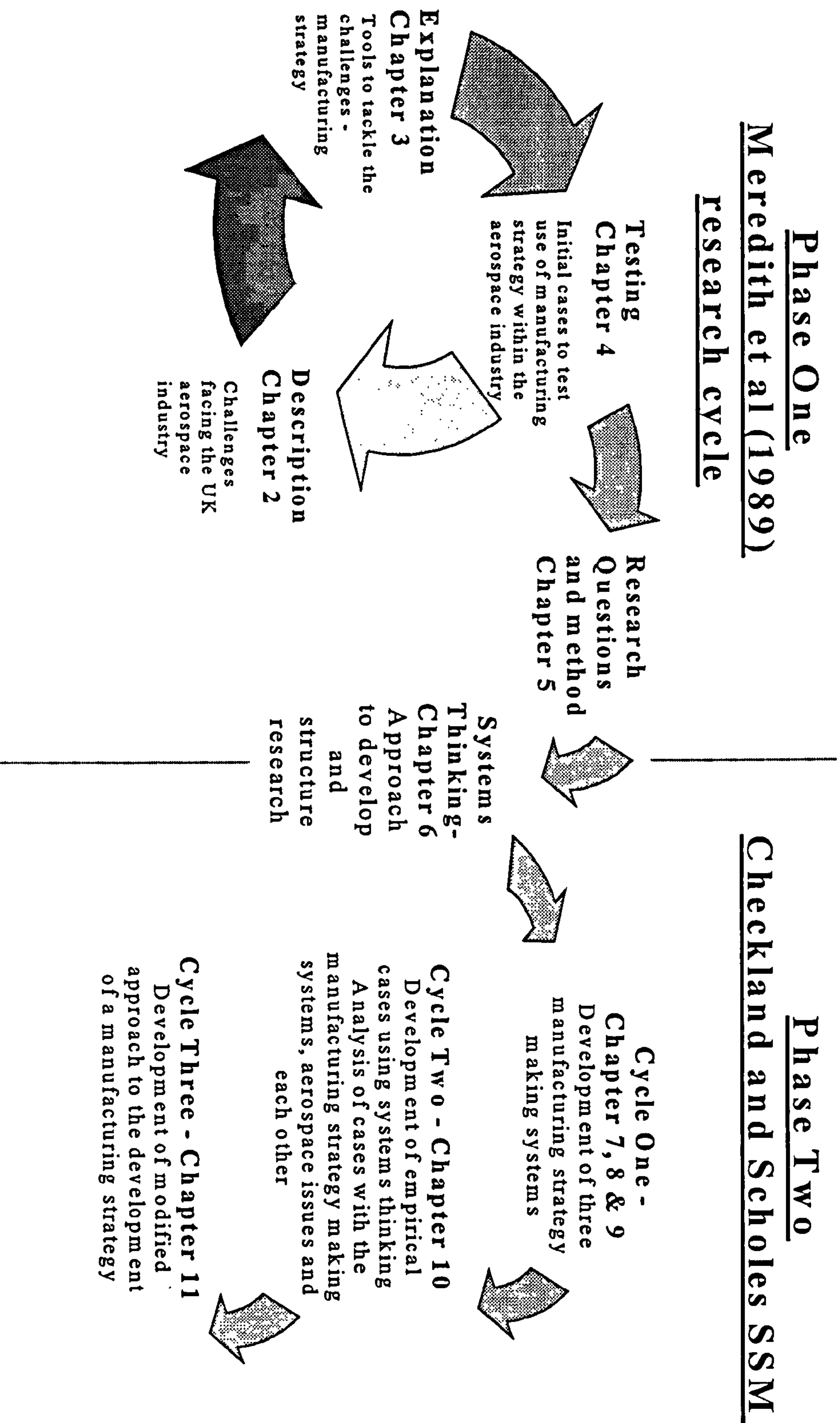

Figure One – Thesis Structure

The above principles were established from the current literature and developed using three cycles of learning using systems concepts and the soft systems methodology developed by Checkland and Scholes (1990) as illustrated in figure one – thesis structure. Cycle One identified the use of manufacturing strategy within the UK aerospace industry as a ‘problem situation’ which was worthy of further study. Using current literature as a starting point, three manufacturing strategy archetypes were developed using root definitions, conceptual models and systems concepts to provide three manufacturing strategy-making systems. The archetypes were identified as the customer focussed / market led approach, the best practice approach and the knowledge-based approach to manufacturing strategy.

Cycle Two explored the manufacturing strategy formulation process experiences of seven UK aerospace organisations and provided a base to identify changes to current manufacturing strategy methods, which would be appropriate to the aerospace industry. The outcome of this cycle indicated that the majority of cases visited did not have a formal manufacturing strategy-making system in place, although tended to use the best practice approach with some evidence of a market led focus. Only Case I was considering the competence / knowledge-based view. Few case organisations had a formal process by which to develop their manufacturing strategy and to keep the momentum going within their change programmes. However all recognised the need and the benefits of applying strategic thinking to their manufacturing processes.

The implications of the findings were that either the current manufacturing strategy methods were not presented in a manner which was compatible to the aerospace industry’s evolution or that a structured systemic method which was capable of dealing with manufacturing competitiveness within a business process focussed organisation was not available. The results of this cycle are described in Chapter Ten. This cycle identified the benefits of taking a soft systems approach to the formulation of a manufacturing strategy

due to the different views held by manufacturing stakeholders, the messy problem of manufacturing strategy and ensuring participation of key stakeholders.

Cycle Three developed a modified approach to the formulation of a manufacturing strategy from the results of Cycles One and Two. The approach was developed using the soft systems methodology as a frame of reference, and the concepts of systemicity, debate, and continuity. The approach developed existing manufacturing strategy methods and evolved them into a format that may be compatible with a process-focussed organisation, such as one that incorporates a business process view across traditional functions and disciplines.

The approach enables the practitioner to question the current business strategy and manufacturing's contribution to achieving the targets set in the business strategy. The approach leads the practitioner through the process of understanding the current manufacturing organisation, assimilating data from the key stakeholders, reaching consensus on contentious issues and producing a shared understanding of the current manufacturing operation.

The next phase of the approach develops a statement of what is expected from the manufacturing organisation, linked to the business strategy and a discussion of the appropriate manufacturing strategy archetypes which could be useful and fit their particular organisation. Objectives are developed from the manufacturing strategy statement, and relevant systems which may be people based, process based or technology based (or a mixture) are identified which will have a significant role in achieving those objectives. These systems may or may not exist at this stage. The systems identified are described using a root definition, which focuses the practitioner in defining exactly what the system is to deliver. The root definitions are used to develop conceptual models based on the different worldviews expressed by the stakeholders.

The conceptual models are compared with the real world situation to identify systemically feasible and desirable changes to the current manufacturing organisation in

line with the business strategy and manufacturing objectives. The mechanism chosen to deliver the approach was a facilitated workbook, which was tested and validated in two aerospace organisations and one Small to Medium sized Enterprise, (an enterprise with less than 250 employees) using the criteria that research should be useful to practitioners within the production and operations management domain (Thomas and Tymon, 1982).

The approach was successfully validated in the organisations through the use of discussion, focus groups, and workshops. The validation played an important role in developing the usability of the approach, as the concepts underpinning the approach were designed to be useful to operations and production management practitioners. The development of a rich picture of the manufacturing operation in two cases, L and M, exposed different worldviews, which were held by the key stakeholders. This was felt to be extremely beneficial in future stages of the approach when identifying the preferred direction of manufacturing and the systems required to deliver the strategy. Both organisations articulated the usefulness of the structure of the approach and the identification of relevant systems to support the business strategy and manufacturing objectives as being very useful. These comments are included in Appendix Four.

The practitioners felt that the use of systems concepts and the principles of debate, continuity and systemicity was beneficial in developing an understanding of the current manufacturing operation and the required changes to support the business strategy being followed. This cycle is described and discussed in Chapter Eleven.

1.6 Contribution

The contribution of the work comes from the critical evaluation of existing manufacturing strategy methods and techniques against the needs of the evolving UK aerospace industry. This evaluation determined that the above were not well enough developed for the industry due to the change from predominantly functionally aligned

organisations towards a business process focus. Platts et al (1996) identified the need and usefulness of using a manufacturing strategy formulation process to enable manufacturing organisations to become remain competitive. Opportunities for improvement were identified by the author to current manufacturing strategy methods, which were incorporated into a modified approach for formulating a manufacturing strategy. The method addressed the issues identified.

The approach makes use of three manufacturing strategy archetypes, defined using systems theory, to ensure the thinking surrounding the manufacturing strategy is explicit and is systemic. The three archetypes have been incorporated into a manufacturing strategy meta model, which describes the linkages and suggests the preferred position of each archetype in a manufacturing strategy hierarchy. The mechanism for disseminating the contribution was a workbook which is included in Appendix Three.

The modified approach to manufacturing strategy formulation has been successfully validated on the premise of the work being useful to the practitioner and has been identified as being a useful and exciting approach to formulating manufacturing strategy. The approach was developed for use within the UK aerospace industry, however the practitioners involved in the validation believe the approach could be useful in other sectors of industry. The approach has continued to be developed in industry.

The use of soft systems methods as a tool to understand manufacturing strategy-making systems is also part of the contribution of this thesis. Three cycles of Checklands (1990) Soft System Methodology were used to:

- define three manufacturing strategy archetypes in systems terms,
- develop seven empirical cases of aerospace organisations approaches to manufacturing strategy,
- compare three manufacturing strategy archetypes with the empirical cases,
- identify feasible changes to current manufacturing strategy-making systems and

- develop a modified approach to the formulation of a manufacturing strategy using soft systems thinking.

1.7 Thesis structure

Chapter One introduces the research and describes the evolution of the project. **Chapter Two** introduces the UK aerospace industry and describes the evolution of the manufacturing operation and organisation within the industry. The importance of the industry to the UK economy is discussed and the potential contribution of manufacturing to competitiveness of the industry is explored. **Chapter Three** develops the concept that manufacturing can be used as a key enabler to organisations becoming competitive. The chapter reviews the current manufacturing strategy literature and demonstrates how the manufacturing operation contributes to the competitiveness of an organisation. Three manufacturing strategy archetypes are described and discussed. **Chapter Four** introduces the initial case studies (A, B and C) which identified the need for further research into the UK aerospace's use of manufacturing strategy.

Chapter Five develops the research methodology introduced in this chapter and identifies the needs of the practitioner as a key research success measure (Thomas and Tymon, 1982). The description, explanation and testing phases of Meredith's (1989) research cycle are developed and integrated with the learning cycles of the Checkland and Scholes (1990) Soft Systems Methodology. The use of case study research is introduced and discussed. **Chapter Six** introduces the concepts underpinning systems theory and the business process paradigm and describes the suitability and usefulness of systems to underpin the research.

Chapters Seven, Eight, and Nine use the systems approach introduced in Chapter Six, using the bridging research strategy to develop the theoretical base of manufacturing strategy. Systems thinking is used to develop three manufacturing strategy archetypes

identified in Chapter Four into manufacturing strategy-making systems. **Chapter Ten** continues the cycle of learning by presenting the experiences of seven UK aerospace organisations of manufacturing strategy in systems terms as a manufacturing strategy-making system. The conceptual models were compared with the three manufacturing strategy-making systems developed in Chapters Seven, Eight, and Nine. The comparisons were used as a basis to identify possible changes and improvements to current manufacturing strategy formulation processes.

Chapter Eleven incorporated the changes identified in Chapter Ten into a modified approach to a manufacturing strategy formulation process. The modified approach uses the principles of systemicity, debate, and consensus to develop current manufacturing strategy methods to suit the current evolutionary path of the UK aerospace industry. The approach is delivered as a workbook format and validated with the point of view that it should be useful to operations practitioners. The evolution and validation of the approach are described and discussed. **Chapter Twelve** presents results of the work, conclusions and the contribution,.

1.8 Summary

The introductory chapter has provided the foundation for the research and an overview of the thesis content. The evolution of the research has been presented and the key concepts underpinning the research have been introduced. The following chapter – ‘Issues facing the UK aerospace industry’ will explore the evolution of the industry and the current issues that it is currently facing.

2 Chapter Two - The challenges facing the UK aerospace

industry

Chapter Two has the following objectives:

- to describe the evolution of the UK aerospace industry and its position in the global competitive arena,
- to assess the key challenges that the industry will face in the future, and
- to discuss how the industry could address these challenges through its manufacturing capability.

The chapter concludes with identifying manufacturing strategy as a key competitive enabler that is necessary in ensuring the aerospace industry can meet the opportunities and demands of the global market place.

2.1 Evolution of the UK aerospace industry

The industry can trace its origins back to the early twentieth century, and the subsequent economic and technical developments of World War One, which formed the catalyst for the emergence of the aerospace industry in the UK. The emergence of the industry coincided with the work of Frederick Taylor (1911) who developed Adam Smith's (1910) Pin Factory experience into the principles of scientific management. This influenced the evolution of aerospace organisations into the functional hierarchical structure that we have today.

Following the end of the war, several organisations embraced civil aircraft production, these included de Havilland with the Moth, and Shorts Brothers with the monoplane Empire flying boats. In 1937 the first jet engine was designed and built by Sir

Frank Whittle. With the onset of World War Two most aerospace companies switched back to military aircraft production.

The 1950's heralded the new age of the commercial jet aircraft passenger service The Comet - with mainstream airliners being introduced in the 1960's. The 1970's were a turbulent time for the UK aerospace industry. The economics of aviation were transformed by the rapid increases in oil prices and fierce competition between commercial airlines to reduce prices. This gave rise to the need for lighter and stronger materials to improve fuel economy. In the defence arm of the industry cost-plus contracts were the norm. This meant that industry was paid the cost of developing and producing the aircraft with a guaranteed percentage of profit built in. Demand rapidly expanded and the industry enjoyed large profits. These profits concealed the actual performance of the industry in terms of efficiency and effectiveness (Roe, 1997).

In the early 1980's the industry enjoyed a period of prosperity. Military contracts were still awarded on a cost-plus basis and the philosophy was "quality at any cost". However, during the late 1980's both the defence and civil markets declined due to several events that resulted in a reduction in demand. A fall in expenditure of 15% was recorded between 1987 and 1990 (Bishop, 1997)

The collapse of the Warsaw Pact and the 1980's recession had a profound effect on the global industry (Papin and Kleiner, 1998). The 'peace dividend' changed the way the procurement agencies awarded contracts. Fixed price contracts replaced cost-plus, and were paid according to milestones with severe penalties for milestones missed. This gradually changed the operating philosophy of the industry and is still having an impact. Competition increased through mergers of existing manufacturers and the development of new products from the Far East, and became a major issue in the industry's survival. Expenditure within the aerospace market fell a further 10% in the first half of the 1990's (Bishop, 1997).

Order winners and qualifiers of the market changed dramatically. Customers in both the defence and commercial aerospace market became more aware of the issues concerned with quality, value for money and lower life cycle costs teamed with greater reliability and maintainability. Numerous contracts were cancelled or reduced, such as the Tornado contract that led to a need to rationalise to remain competitive. Continuous improvement at the operational level was identified as a factor of survival (SBAC, 1998).

The industry had to change to meet the competitive pressures that included a shrinking market due to changes in procurement policy and the erosion of the barriers to entry to the market due to the development of technology. The civil market is now picking up again with new orders being placed by the airlines to cope with the increase in passengers (Papin and Kleiner, 1998). Prime contractors and systems integrators responded to these changes by seeking to involve their suppliers in improvement projects and by forging closer links (Papin and Kleiner, 1998)

Globalisation of the industry was slightly moderated by the proliferation of technology transfer agreements, and further collaboration in the design and manufacturing of products. In the new millennium survivors of the global aerospace industry will need to achieve performance standards that match the best in their field. It was predicted that only three major organisations would survive into the 21st century (SBAC, 1996).

The aerospace industry is an important wealth creation sector of the UK economy and needs to respond to these competitive pressures. This is reflected in the latest figures released by the Society of British Aerospace Companies (SBAC). The industry contributed £2.9 billion to the UK's balance of payments in 1996, provides 3% of the UK manufacturing employment, 2.2% of GDP, provides direct employment for 93,000 people, and indirect employment for a further 250,000 (SBAC, 1998). The industry was once characterised as being reactive to opportunities, reactive to problems, with rigid command organisations, multi customer interfaces all controlled by a bureaucracy (Roe, 1997). This

is slowly changing and must continue to change. The industry is now global and therefore the threat to the industry is global (Hesford, 1997).

2.2 The global environment and effects on competition.

The industry is characterised as being 'internationally competitive with surplus capacity' (Ranger, 1997). The globalisation of the industry has made the market more competitive as the former barriers to entry have been overcome. This has occurred through the development of contracts using technology transfer, and collaborations on current contracts such as co-operation agreements between BAe and Malaysia (BAe press release 1997).

The supply chain of the industry is becoming increasingly linked due to the preferred supplier programmes run by organisations such as McDonnell Douglas and British Aerospace (European Community Document, 1995). Suppliers are developing relationships which nurture the need for continuous improvement. Cost reductions are being passed on through the supply chain and the need for continuous innovation has been recognised by the industry (SBAC, 1996).

Roe (1996) identified four major considerations which aerospace organisations should consider when positioning themselves in the market place - politics, demand, technology and supply. The political climate will have a major effect on the defence sector of the industry and will affect budgets and exports. Demand has been in slow decline for a decade and is shaped by changes in need, economic pressures and changes in procurement policy. Technology is changing at an exponential rate and the costs associated with developing and using the latest technology are a problem. Supply has been affected by over capacity in the market (which is being addressed at a national level by industrial collaboration), globalisation, and the question of whether to collaborate or compete (Ranger, 1997).

2.3 Key issues facing the industry

One of the critical issues facing the defence arm of the industry is the shrinking of defence budgets due to pressure from other areas of government spending, which has an effect on the life cycle and procurement cost of products. This has increased pressure on the manufacturing operation within this sector to look closely at their processes and initiate improvement programmes to reduce costs and lead-times, and to increase effectiveness and efficiency in order to maintain competitiveness.

Papin and Kleiner (1998) identified three approaches to the key issues. Organisations are either looking at flexibility to achieve cost reduction strategies, core competencies to achieve a niche strategy or looking at Total Quality Management (TQM) and human resources.

The competition for global dominance was and remains the major factor concerning the fate of the aerospace industry as a whole. Competition is coming from all angles with cheap, second-hand aircraft being made available from the former Soviet Union. Contracts are increasingly linked to offset deals and technology transfer with the effect of reducing the barriers to entry to the market (SCRIA, 1997)

The costs of developing new aircraft are high, therefore collaboration between aerospace companies is increasing. The consequence of this is that improvement initiatives pursued by one aerospace organisation will have implications for the rest of the industry through the supply chain (SCRIA, 1997).

The industry operates as a hierarchy with prime contractors being awarded major contracts. The prime contractor is responsible for the final assembly of the aircraft or complete weapon system. Contracts are filtered throughout the industry through a tier system of systems integrators, sub assemblers, detailed manufacturing (component parts) and consumables, as shown in Figure 2.

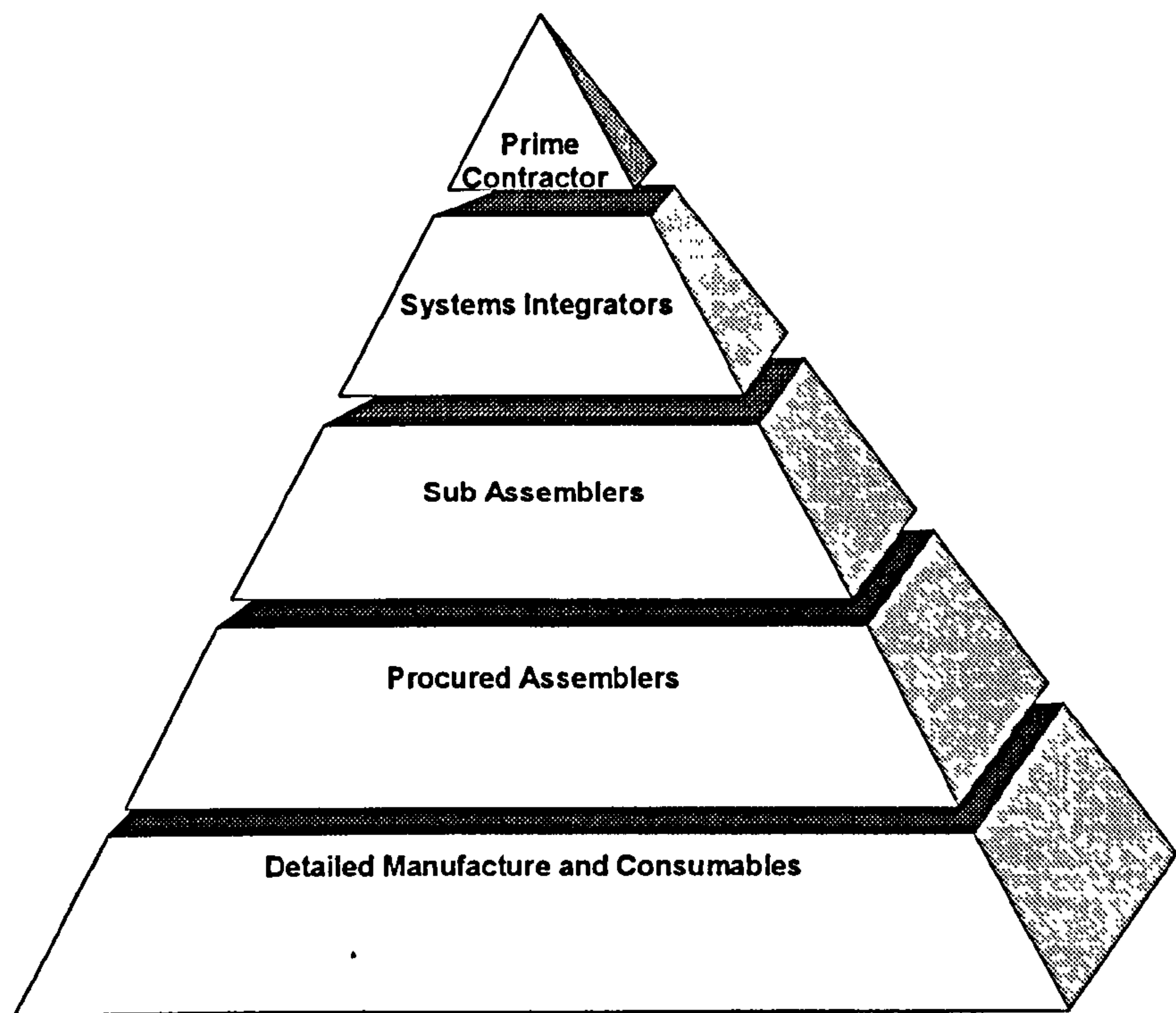

Figure 2 - The structure of the UK aerospace industry

Best practice has filtered through the industry through the SBAC Competitive Challenge Initiative and the Engineering and Physical Sciences Research council's Innovative Manufacturing Initiatives (IMI). Larger aerospace companies are aligning their organisations around key business processes and have identified the importance of manufacturing as a key role in defining and developing the competitiveness of the industry.

SBAC was formed to promote the interests of the industry to various bodies such as the government. The SBAC launched a competitiveness challenge to provide aerospace companies with the opportunity to learn from each other and to adopt best practice in several key areas. The following are the key factors identified by industry which affect competitiveness (The SBAC competitive challenge pack, 1996, 1998)

Key Factors Affecting Competitiveness

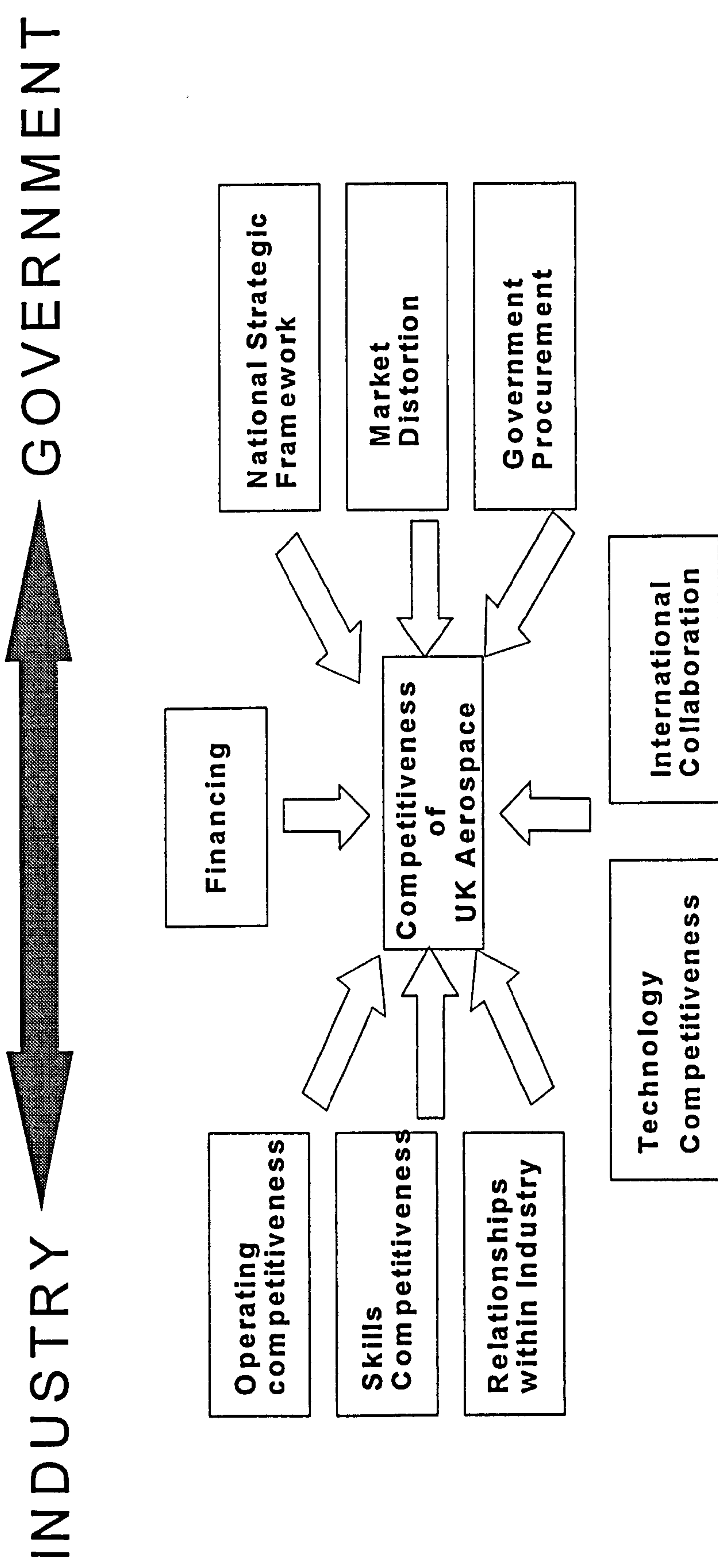

Figure 3 - The SBAC Competitiveness Challenge

The key challenges facing the industry have been summarised by the SBAC as the following:

- to maximise the effective and efficiency of individual organisations
- to maximise the effectiveness and efficiency of the supply chain
- to focus on concurrent engineering and reducing the lead times of current and future projects
- to focus on continuous improvement (SBAC, 1996, 1998)

It is important to point out that strategy and manufacturing strategy appears to be missing and it is important to consider the role of the manufacturing operation and strategy in meeting these challenges.

2.4 The role of manufacturing and manufacturing strategy

The effect of cost plus contracts on the evolution of manufacturing within the aerospace industry was to place the emphasis on technological excellence in the design of aerospace systems as opposed to operational excellence. The impact of this was brought home when the procurement philosophy changed to fixed price contracts.

Manufacturing had to respond to completely different success factors and the manufacturing systems that had evolved were not capable of meeting these challenges. This has been evident throughout the supply chain and especially evident in the early 1990's when a large proportion of the aerospace industry reassessed their operations resulting in massive restructuring. Factories were closed and the ones that remain are slowly changing their operating philosophies.

However with the emergence of stiffer competition, it is becoming even more critical to rationalise and remove non-value added activities. It is also crucial for aerospace organisations to focus on customer requirements and to ensure that the

manufacturing operations are able to support these requirements. With all of these changes, the manufacturing operations within aerospace organisations can no longer behave in the way that they historically did. Strategic decisions need to be taken within manufacturing to ensure the value adding features of manufacturing are considered as part of the overall journey of the organisation and are not seen as an add on.

Manufacturing strategy has been identified as a critical tool that is essential in the restructuring of the aerospace operational base. The current move to business process focussed organisations reinforces the view that manufacturing operations must be aligned to customer requirements and must be used as a competitive asset rather than a millstone (Skinner, 1969).

The following Chapter introduces the concepts of manufacturing strategy and puts into context how the challenges facing the UK aerospace industry can be met through the development and use of manufacturing strategy methods.

3 Chapter Three - Manufacturing Strategy

The preceding chapter introduced the UK aerospace industry as the focus for the research and identified the issues affecting the competitiveness of the industry. The role of manufacturing in developing the competitiveness of the industry was presented. Manufacturing strategy was identified as a critical component in developing the role of manufacturing in enabling the overall competitive success of the industry.

This chapter describes and evaluates the usefulness of current manufacturing strategy theory and presents the current literature using the three manufacturing strategy archetypes identified by Whittle et al (1994).

3.1 An introduction to strategy

Before introducing the reader to manufacturing strategy it is important to briefly describe strategy in general. Quinn et al (1988) have articulated strategy as:

'The pattern or plan that integrates an organisation's major goals, policies, and action sequences into a cohesive whole. A well formulated strategy helps to marshal and allocate an organisation's resources into a unique and viable posture based on its relative internal competencies and shortcomings, anticipated changes in environment and contingent moves by intelligent opponents.'

But why is strategy so important? Strategy is all about positioning people, processes, and technology within the organisation to ensure it is competitive and to ensure survival. Strategy is about making choices about the essence of the organisation, the direction the organisation wants to go in, and the journey that the organisation takes to get there. It is therefore a critical component of Production and Operations Management and is of interest to researchers who are concerned with the contribution that the production

and operations field can make to the competitiveness of an organisation and the economy as a whole.

Numerous authors such as Porter (1990), Ackoff (1981), Ansoff (1965), Peters and Waterman (1982), and Harrison and Pelletier (1998) have written about the foundations of strategy and its effect on organisations and its importance. Hamel and Prahalad (1993) have also talked about the importance of strategic intent and the importance of leveraging and stretching core competencies in order to provide a competitive advantage.

3.2 Hierarchies of Strategy

In business, strategy is usually developed as a hierarchy (Johnson and Scholes, 1997). The hierarchy generally includes a corporate strategy, which addresses the core business of the organisation and sits at the top of the hierarchy. The questions asked are 'what business are we in?' An example of this could be 'is it the 'bit' making business, the assembly business, or the after sales support business?' The 'core business' of an organisation is the reason why the organisation exists. The next level in the hierarchy addresses the business strategy. This addresses how the organisation should compete in the chosen core businesses and finally the functional strategies determine how specific functions contribute to the achievement of business goals and subsequently the competitive advantage of the business. An example of this would be the manufacturing organisation aligned to provide the customer with delivery reliability if for example the customer was working to a Just-in-time philosophy. Stobaugh and Telesio (1983) reiterate this point by talking about matching manufacturing policies with product strategies. Manufacturing strategy can be at various positions within the hierarchy, either as a functional strategy or at the business level.

3.3 Manufacturing strategy

Manufacturing strategy has been defined as

'The decisions and plans affecting resources and policies directly relating to the sourcing, production and delivery of tangible products'

(Swink and Way, 1995). Another definition presented by (Swamidass and Newell, 1987) is:

'The effective use of manufacturing strengths as a competitive weapon for the achievement of business and corporate goals'.

Manufacturing strategy can be described as both a journey and a direction, with the direction being the focusing of the manufacturing operation within its market and competence base, and the journey encompassing the methods used to achieve that focus. The journey can include a specific change programme for example.

Mintzberg and Waters (1985) have tackled the question of whether a strategy emerges or is planned. Mintzberg's view is that 'strategy emerges as the result of an organisations learning and market conditions'. Strategy formulation is seen as a messy process rather than a rational planned process. This has been verbalised by Martin et al (1994) who described the experiences of managers who say 'strategies have emerged.... It was the only action they could take at the time'. They continue 'manufacturing strategy formulation does not appear to involve a rational process of decision making or choosing between alternatives, decisions are taken because of managers preferred models of manufacturing competences'. These models include customer focused manufacturing, lean production, world class manufacturing and the learning organisation. Hill (1996), Skinner (1978, 1985) and Kaplan (1991) take the view that a 'process for rational planning' is useful and that 'generic strategies give a road map to planning'. Two states of strategy have emerged from the literature – intended and realised, and two types of implementation process – deliberate and emergent. Quinn et al (1988) suggest that purely deliberate or purely emergent strategy are unlikely.

A manufacturing strategy is a useful concept in enabling an organisation to position its people, processes and technology to enable the development and creation of new markets as and when appropriate (Hayes and Wheelwright, 1984).

Before reviewing the literature it is necessary to consider why it is important to research the area.

3.4 The manufacturing strategy research domain

Specific interest in manufacturing strategy can be traced back to Skinner's seminal paper (1969). He described the use of manufacturing as a competitive weapon as opposed to a function which is passive to its competitive environment. Skinner also introduced the concept of the focussed factory (1974) that advocated splitting factories into separate units based on a market focus.

Buffa (1984) has identified three main phases of operations management which have a bearing on the development of the manufacturing strategy domain. In the 1950's researchers were interested in industrial and factory management. Studies included time and motion, plant layout, production control and queuing theory. At this time the main assumptions were that the production was cut off from the surrounding environment, technical issues were the most pressing, and the objective was to achieve maximum production output from employees (Fillipini, 1998).

In the 1960s and 70s the scope was broadened to look at operations management with the result of applications becoming more abstract with little use to the production and operations management practitioner (Filippini, 1997). In the 1980's manufacturing strategy was perceived as being important and operations management began to emerge as a functional field of management.

The 1990's have provided a lot more scope. Manufacturing is now recognised as being strategically important and operations management is becoming more integrated

with other areas of research. Voss (1995) has identified three main elements to manufacturing strategy that will be discussed in more detail later - competing through manufacturing, strategic choices and best practice. Operations management research has been criticised for being too implicit or difficult for researchers to articulate and suffers from a lack of theory development and empirical research. This will be considered when formulating subsequent research questions and the research methodology.

3.5 The benefits of researching manufacturing strategy

Manufacturing is a critical value adding operation within an aerospace manufacturing organisation and the ability to develop and sustain manufacturing capabilities to support and/or to develop the strategic direction of that organisation is an asset. Poor operating performance has been attributed not only to operating inefficiencies but also to poor strategic decisions (New and Myers, 1986). Researching the area of manufacturing strategy should provide the practitioner with useful methods to enable them to develop a feasible and useful manufacturing strategy.

Feurer and Chaharbaghi (1995) and Westbrook (1995) reiterate the need for research into strategy formulation to provide integrated and holistic research to enable the practitioner to gain the optimum benefit from any theories or methodologies developed.

3.6 Researching manufacturing strategy

Manufacturing Strategy has been the basis of many empirical studies and has led to the development of models in order to describe and understand the phenomenon. Hayes and Wheelwright (1984) developed a four-stage framework indicating the evolution of the manufacturing function as a strategic entity. The framework is used in the analysis of the initial case study data to provide a scale for the view of manufacturing and its role within each organisation. The four stages are internally neutral, externally neutral, internally

supportive, and externally supportive. The following narrative is developed from Hayes and Wheelwright (1984):

Stage one - internally neutral: The objective of the manufacturer at this stage is to minimise the negative impact of the manufacturing function. The manufacturing function is described as 'inward looking' and tends to be reactive to problems (as opposed to proactive) with a great deal of effort expended on 'fire fighting'.

Stage Two - externally neutral: The objective of this stage is to be as good as the competitor by 'obtaining parity with competitors' (Hayes and Wheelwright, 1984). This may be achieved by following industry best practice. Stage Two may be achieved when the manufacturing organisation begins to look beyond its boundaries to see what other similar entities are doing and to identify appropriate best practice

Stage Three - internally supportive: In this stage manufacturing exists to support business strategy. Manufacturing management is consulted when changes are made in business strategy to ensure congruence within the manufacturing operation.

Stage Four - externally supportive: The fourth stage of the framework describes the phase where manufacturing capabilities shape business strategy in terms of the types of products developed and the ways in which markets are addressed. Manufacturing is seen as the basis for the long term health and success of the organisation. Manufacturing is seen as being proactive and innovative in its approach to development and everyday operations.

Hayes and Wheelwright's (1984) framework is useful for analysing the manufacturing operations' strategic role in an organisation. The Hayes and Wheelwright framework has been further developed by Hum and Leow (1996). They began to populate the stages with methods and philosophies. It appears that a large amount of manufacturing strategy literature

focuses on Stage Three of the model, that is, where the manufacturing operation supports the business strategy. A great deal of the empirical research into manufacturing strategy suggests that the majority of manufacturing organisations are at Stage One or Two (Voss, 1995). Questions should be asked as to why this is the case. One possible reason could be that current manufacturing strategy methods are not well enough developed to take manufacturing organisations to the next phase. This is supported by the view of Feurer and Chaharbaghi (1995) who believe that many models have a narrow focus and a lack of relevance. They perceive the need for a holistic approach to strategy research that uses a number of learning cycles.

3.7 Manufacturing Strategy – Content and Process

Manufacturing strategy has traditionally been divided into content and process (Swink and Way, 1995). The content of manufacturing strategy can be described as the ‘what’ of manufacturing strategy, and the process of manufacturing strategy the ‘how’.

3.7.1 Manufacturing Strategy – Content

Various descriptions of content include, ‘the ‘what’ of strategy, objectives, decisions and final result (Anderson et al, 1991), and the ‘the behaviours, policies, plans and values that are espoused within the strategy’ (Swink and Way, 1995). However the model used to describe the content of manufacturing strategy within this research comes from Boyer (1998).

The content of manufacturing strategy according to Boyer (1998) consists of the:

- competitive priorities that are similar to Hill (1989) order winners and qualifiers, which will be explained later in this chapter.
- structure of manufacturing that consists of the decision areas of capacity, facilities, technology, and vertical integration.
- manufacturing infrastructure that consists of the workforce, quality, production planning, and the organisation.

Hayes and Wheelwright (1984) have also identified key decision areas within a manufacturing strategy, which are useful reference points in describing each different manufacturing strategy archetype and their attributes.

These decision areas include: performance measures, organisation, new product development, capacity, facilities, process technologies, vertical integration, human resources, quality policy, production planning and manufacturing control, and customer focus. These will be described in more detail below in Table 1.

Table to identify the decision areas in manufacturing strategy

<i>Capacity</i>	<ul style="list-style-type: none"> • Product plans, resource – people and equipment, flexibility, similarity of products, planning accuracy
<i>Facilities</i>	<ul style="list-style-type: none"> • Number, location and focus. Multi site? Single plant? Product line?
<i>Process technologies</i>	<ul style="list-style-type: none"> • Requirements of product technologies and markets. Technological availability and risk implications.
<i>Vertical Integration</i>	<ul style="list-style-type: none"> • Direction and extent of product span
<i>Human resources</i>	<ul style="list-style-type: none"> • Definition of job structure. Technical competencies, problem solving capabilities, use of teams. Integrating the human-machine interface
<i>Quality Policy</i>	<ul style="list-style-type: none"> • Fitness of process and product for purpose
<i>Production planning / materials control</i>	<ul style="list-style-type: none"> • Project and financial control systems to suit the organisational structure
<i>New product development</i>	<ul style="list-style-type: none"> • Selection, cultivation and development of new products
<i>Organisation</i>	<ul style="list-style-type: none"> • Organisation structure to suit the product and market requirements and altering it as the requirements change
<i>Performance measurement and reward</i>	<ul style="list-style-type: none"> • Development and operations of systems to generate data about functional performance against financial and non financial parameters
<i>Customer focus</i>	<ul style="list-style-type: none"> • Future and current needs of the customer - are these addressed?

Table 1 – Decision areas (Hayes and Wheelwright, 1984)

3.7.2 Manufacturing Strategy – Process

The process of manufacturing strategy is characterised by the activities, issues and models associated with developing a strategy for a specific organisation (Adam and Swamidass, 1989). The importance of the process of manufacturing strategy formulation has been well documented by Adam and Swamidass (1989), Voss (1992), Hill (1985), and Platts and Gregory (1989 and 1990).

Platts (1993) introduced four aspects that could be useful in analysing and explaining the constructs involved in the process of manufacturing strategy formulation. These include the point of entry, participation in the formulation process, the procedure or methodology followed and the project management of the process such as the timing and frequency of the process. These aspects will be developed in more detail below.

3.7.2.1 Point of Entry

Platts (1993) argues that an organisation must see the benefits of using a manufacturing strategy approach before any such process can commence. Therefore it is important that the key process stakeholders are provided with some form of evidence that the process will be useful. Hill (1985) and Platts (1993) both suggest some form of competitive profiling, to show any misalignment between how products compete in the market place and how the manufacturing function supports the business objectives.

Competitive profiling is used to show the mismatch between market requirements and achieved performance, resulting in the identification of the benefits of a particular manufacturing strategy approach. An example of competitive profiling is shown below in Figure 4., provided by Platts and Gregory (1989).

Market Requirements

Achieved Performance

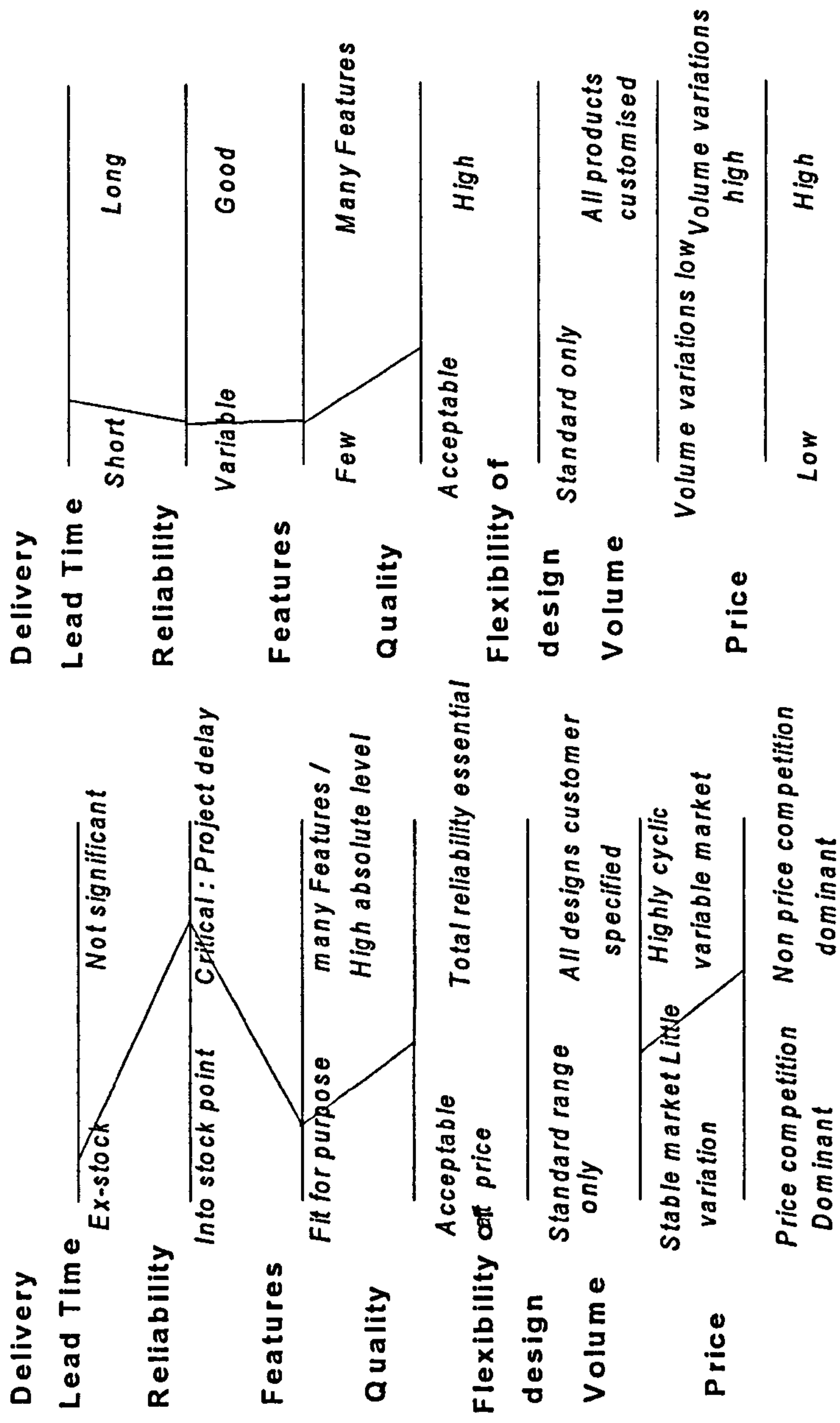

Figure 4 Competitive profiling (Platts and Gregory, 1989)

The market requirements are what the customer expects from the product and can be related to Hill's (1985) concepts of order winners and order qualifiers. Order winners and qualifiers will be explained fully in the description of the market led / customer focussed manufacturing strategy archetype. The achieved performance is what the manufacturing systems can currently delivery. The profiles are overlaid to identify any mismatches. This is a very powerful trigger to show what aligning the manufacturing system to customer's requirements can achieve and has been used as part of the modified approach which is included in Appendix Three.

3.7.2.2 Participation

The participation aspect of the manufacturing strategy formulation process addresses the identification of the stakeholders from other functions or processes within the organisation who should be involved. It is widely accepted that manufacturing should be closely aligned to market requirements, (Hill 1985, Platts and Gregory 1989, Voss 1992). Therefore it is important to ensure that marketing factors such as product / project order winners and order qualifiers within the market are addressed and considered in the development of a manufacturing strategy. Therefore it is important to ensure the marketing stakeholder is included in the process.

3.7.2.3 Procedure

The actual procedure or process that is followed in the development of a manufacturing strategy can be a planned activity following a developed methodology such as from Hill (1985) or Mills (1995). The process can alternatively be seen as a result of a series of significant events resulting from the pattern of actions implemented (Mintzberg and Waters, 1985). This has been described as an emergent form of strategy making, and is useful

to determine how the company has evolved to identify those factors that may affect the successful implementation of a strategy in the future.

3.7.2.4 Project Management

The fourth aspect introduced by Platts (1993) is that of project management. The two major issues identified are those of adequate resourcing for the management, support and operations groups and a specific timescale for producing a strategy. Strategy making should be considered as a continuous process as the strategy should be responding to the environment and competitive pressures and changing accordingly. It is important to include specific timescales within the manufacturing strategy formulation process to ensure that any major changes in infrastructure or the development of a new technology are linked to the business planning cycle within any particular organisation.

3.8 Frameworks used to describe manufacturing strategy

Empirical research into the domain of manufacturing strategy has provided the operations practitioner with several prescriptive models and generic strategies to aid in developing and implementing a manufacturing strategy.

Various authors have developed frameworks to help to describe the manufacturing strategy domain. These include Mills et al (1995) which is shown in Figure 5, Voss (1995) who identified three main paradigms for manufacturing strategy. Hayes and Wheelwright (1984) developed the four stage methodology which was described earlier. Bolden et al (1997) which is used to describe a framework for the content of manufacturing strategy. Keong and Ward (1995) who introduce the 6 P's of manufacturing strategy which include planning, proactiveness, pattern of actions, portfolio of manufacturing capabilities, programme of improvements and performance measurement. Miller and Roth (1994)

introduced the concept of generic manufacturing strategies that incorporated a caretaker, marketer, or innovator approach.

Mills et al's (1995) manufacturing strategy framework has been used to develop the research. The framework describes the field using the common themes of content and process. They also introduce the concept of 'Qualities of the process outcome' which places performance measures within the process of manufacturing strategy formulation. As a framework to describe manufacturing strategy it has several merits. The framework divides the area into content, process, and qualities of process outcomes and provides a starting point to show what is involved in each strand. Manufacturing strategy content is presented as including the objectives, decision areas and hints at the three manufacturing strategy archetypes by mentioning best practice strategies, and capability and competence. The process of manufacturing strategy is presented as the point of entry, participation, procedure and process management which have been discussed previously. The qualities of the process outcome are the reality checking of the manufacturing strategy. The framework is presented in Figure 5.

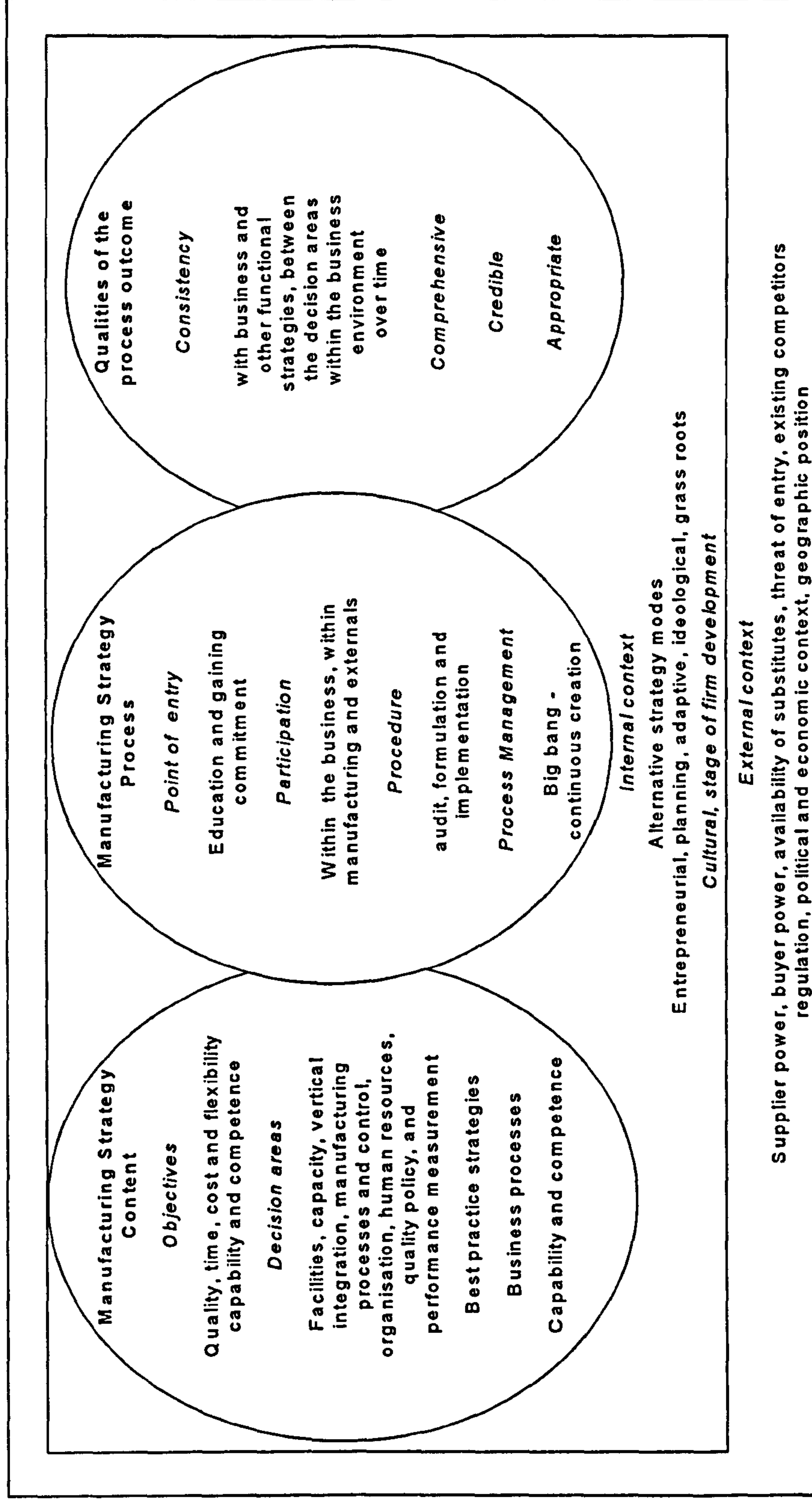

Figure 5 Manufacturing strategy framework (Mills et al, 1995)

The framework provided by Voss (1995) has been very useful in framing the research. Voss presents three different ways of looking at manufacturing strategy. The three paradigms articulated by Voss include:

- Competing through manufacturing which takes into consideration order winners, key success factors, capabilities, generic manufacturing strategies and shared vision.
- Strategic choices which includes the contingency approach, internal and external consistencies, choice of process, manufacturing infrastructure and kaisen.
- Best practice includes world class manufacturing, benchmarking, business process re-engineering, total quality management, Japanese production methods and kaisen.

These three paradigms are described by Voss (1995) as occurring in cycles. The paradigms are used in the research, but are slightly modified to become the approaches identified by Whittle et al (1994) as the market led approach, best practice approach and the knowledge-based approach. These approaches will be described in more detail in this chapter.

When considering the current manufacturing strategy literature, archetypes have been useful in setting a boundary around the area under consideration. Archetypes have been defined as

'Clusters of prescribed emergent structures and systems given order and coherence by an underpinning set of ideas, values, and beliefs for example an interpretation system'

(Hining and Greenwood, 1989).

3.9 Three manufacturing strategy archetypes

The approaches that have been identified by Whittle et al (1994) are defined in this section. Each archetype is described using the following criteria:

- Evolution of manufacturing strategy archetype
- Content of manufacturing strategy archetype, which includes the main theme, objectives, general policies, plans, values and behaviours (Swink and Way, 1995), competitive priorities, infrastructure and structure (Boyer, 1998).
- Process of manufacturing strategy archetype, which includes the conceptual models developed, and tools and techniques available.

Conceptual models have been developed to facilitate the use of manufacturing strategy process methods and ideas, such as Hills methodology (1985 and 1993). In this research a concept is defined as:

'a bundle of meanings or characteristics associated with certain events, objects or conditions and is used for representation, identification, communication or understanding'

(Meredith, 1993)

Therefore a conceptual model as derived in this research is used as a model of a concept. These conceptual models assume that the process of manufacturing strategy formulation is a rational process, however Mintzberg (1978) takes the view that strategies can emerge as a result of a variety of factors. He argues that a strategy can be planned or it can emerge as a pattern can be seen retrospectively. He considers that it is important for the manufacturing organisation to recognise emergent strategies, as the emergent strategy will have an impact on the process of formulating a planned manufacturing strategy. An emergent strategy will have played a part in the formulation of current behaviours and values held within the manufacturing operation and the organisation as a whole.

3.9.1 The market led / customer focussed approach to manufacturing strategy

3.9.1.1 Evolution

The evolution of the market led / customer focussed approach to gaining competitive advantage within manufacturing began with Skinner's (1969) view of the focussed factory and corresponding decision areas. The approach is linked to business strategy, and is developed by gaining an understanding of the customer and market. Whittle et al (1994) have labelled this approach as 'Outside-in'. This is because the customer requirements shape the manufacturing organisation. Thus initiatives come in from the outside.

3.9.1.2 Content of market led / customer focussed archetype

The main theme for this approach has been articulated by Voss (1995) as 'increase in market share by giving customers exceptional customer service and satisfaction'. The objectives of the approach are to align the manufacturing system with the customers' requirement (Platts and Gregory, 1989) and are generally achieved by driving down lead times, customising products, incorporating special design features of products and services (Hill 1991, Skinner 1971).

The general policies of a market focussed manufacturing organisation tend to focus on several key decision areas, which may include product quality and performance, after sales service, on time delivery and product cost. The values of the organisation (such as what the organisation places most importance on) would be predominantly customer orientated.

The behaviours of an organisation employing this approach tend to be focussed on increasing market share by giving customers exceptional customer service (Voss, 1995).

Competitive priorities are linked to the customers' requirements and have been defined by Hill (1993) as order winners and order qualifiers. Order qualifiers (OQ) have been defined as 'attributes essential to be in the market place, unless products meet this criteria, they will lose orders to competitors' (Hill, 1993). The OWs are the reason why a customer would pick one organisation over another. An order winner is defined 'as the attributes essential to regain market share from a competitor' (Hill, 1993). Order winners/qualifiers (OW/OQ) can also be described as competitive priorities and could be quality, cost, delivery reliability, delivery flexibility, product reliability, after sales service, functionality, or customisation. The order winners and order qualifiers can also be described as the "key drivers" of the manufacturing organisation as identified by Schonberger and Knod (1988).

Hill's (1993) approach is described in section 3.9.1.3. The approach analyses the products of an organisation to determine which specific order winners and order qualifiers are important. The market focussed organisation will seek to align their manufacturing systems and infrastructure with their markets according to the OW and OQ identified (Hill, 1985). For example if delivery flexibility is a key order winner, the manufacturing system would be required to cope with changes in demand quickly, and flexible manufacturing systems may be appropriate.

3.9.1.3 Process of the market led / customer focussed archetype

Several methodologies which embody the essence of the market led / customer focussed approach have been developed by Hill (1993) and Mills (1995) to aid organisations in the development and implementation of their manufacturing strategy. Descriptions of these methodologies are included below. Other authors of note in this area include Draaijer and Boer (1995), who are concerned with designing market oriented production systems. Fry et al (1994) take a service orientated approach to manufacturing

strategy and Bozarth (1997) measures the congruence between market requirements and manufacturing. Gupta et al (1991) reinforce the importance between the relationship between manufacturing strategy and marketing objectives.

Current methodologies for the market led approach concentrate on aligning the manufacturing strategy to the order winners and qualifiers of the current products (OW and OQ are attributes of the product). Relevant production processes are developed to deliver what is required (Hill, 1993). Hill (1994) also says that *'have bought from us before'* can be a qualifier.

Within this archetype, the process of manufacturing strategy formulation has been developed into several usable methodologies (Hill 1985, Mills 1995) that have been tested in industry. An overview of the structure of these methodologies is presented below.

Hill's (1989, 1994) methodology consists of five stages:

1. Define corporate objectives – such as growth or survival, return on investment and other financial measures
2. Determine marketing strategies, such as the product markets, segments and range, incorporating the following: mix, volumes, standardisation versus customisation, level of innovation and leader versus follower alternatives
3. Assess order winners and order qualifiers – how do products win orders in the market place – such as delivery speed and reliability, demand increases, product range, design leadership, technical support
4. Choose and group appropriate processes, which includes the choice of alternative processes, trade-offs embodied in the process choice, capacity, size, timing and location and the role of inventory
5. Design infrastructure and structure. This includes the function support, manufacturing planning and control systems, work structuring, skill levels and organisational structure.

The methodology developed by Mills et al (1995) is described as an iterative process and is presented as a workbook. It consists of six stages.

1. Group products
2. Determine objectives of business
3. Identify current strategy
4. Determine whether current strategy can achieve objectives
5. Align actions with business objectives
6. Install an ongoing process of strategy making

Both methodologies require input from the marketing function to identify the order winners and order qualifiers in the marketplace.

3.9.1.4 Summary of market led / customer focussed archetype for manufacturing strategy

The distinguishing characteristics of this archetype are the linking of manufacturing strategy to business strategy and the focusing on the customer to determine order winners and order qualifiers. The decision areas most important to the values and philosophy of the archetype include product quality and performance, after sales service, on time delivery and product cost. Two methodologies for the formulation process of manufacturing strategy within this archetype have been developed.

3.9.2 The ‘best practice’ approach to manufacturing strategy

3.9.2.1 Evolution

The evolution of the best practice approach to manufacturing strategy began with the phenomenal success of the Japanese to improve their processes and products (Womack et al, 1990). Western industry began to look at how they had achieved such an amazing turnaround and strove to apply principles used in Japanese industry to Western industry. Striving to achieve ‘best practice’ has since become a driving force amongst industry and therefore an important dimension for manufacturing strategy.

The transformation enjoyed by some organisations such as Rover and Milleken through World Class Manufacturing has been attributed to ‘simplicity, overwhelming logic, quick visible results, low cost and personal excitement, fulfilment and rejuvenation’ (Schonberger, 1986). Both these organisations have won the European Foundation for Quality Management award.

The approach is built up around identifying and understanding current issues surrounding people, processes and technology, identifying current best practice through benchmarking and implementing a plan to achieve best practice. This can be achieved via an incremental route, which encapsulates philosophies such as total quality management, and quality awards such as the European Foundation for Quality Management business excellence model. An alternative approach is to go for radical change and improvement using business process reengineering methodologies.

3.9.2.2 Content of the best practice archetype.

The best practice approach to manufacturing strategy encapsulates the ‘World Class Manufacturing’ (New 1992) philosophy and benchmarking, with the assumption that:

'The continuous improvement of 'best practice' in all areas of the organisation will lead to superior performance capability leading to increased competitiveness'
Voss (1995).

The approach:

'captures the breadth and essence of fundamental changes taking place in larger industrial enterprises'
(Schonberger, 1986 and 1996).

The approach has been dominated by Japanese practices (Schonberger, 1986).

Schonberger has described World Class Manufacturing as

'a goal and task that focuses on continual and rapid improvement'.

World Class Manufacturing was initially defined as the use of best practices which were found in excellent companies (Hill 1993, Schonberger 1986).

The objectives of the approach are to achieve world class manufacturing status, to reduce inventory by 50%, reduce lead times by 50%, reduce costs by 30%, and reduce support labour by 50% (New, 1992). Jones (1992) has supported this view but articulates it thus: 'lean production produces 2 to 1 differences in performance between mass production and lean production in every activity from research and development, design, manufacturing, supply and distribution'.

The behaviours, policies, plans and values that drive the approach are driven by the characteristics of simplicity and learning from best practice. Schonberger (1996) describes this approach as principles based management. These include:

The competitive priorities for the best practice archetype have been defined as: Management commitment, Quality, Customer satisfaction, Operations flexibility, Innovation and technology, Facility control, Vendor management, Price / cost leadership, Global competition (Delbridge et al, 1995).

The above are the cornerstones of the best practice archetype which has seen organisations cut lead times by up to 50%, reduce costs and waste, and improve customer satisfaction. Voss (1995) suggests that the origins of best practice have included Manufacturing Resource Planning (MRP II), Optimised Production Technology - Theory of

Constraints, Flexible Manufacturing Systems (FMS), Group Technology, Just In Time manufacturing, Lean Production, Total Quality Management, EFQM, Concurrent Engineering and Business Process Re-engineering.

3.9.2.3 Process of the best practice manufacturing strategy archetype

Voss (1995) has suggested three stimuli for the prominence of best practice within manufacturing. These include Japanese performance, business process approaches, and quality awards such as the Baldrige award and the European Foundation for Quality Management (EFQM) business excellence model. The models for developing this type of approach concentrate on benchmarking and learning from best practice.

The process of benchmarking as described by Camp (1989), Codling (1992), Neely et al (1994), Hanson and Voss (1995) and Watson (1992) incorporate the steps of identifying the current industry best practice by benchmarking other organisations, auditing the manufacturing organisation, carrying out a gap analysis and developing an action plan to close the gap.

Benchmarking has been described as ‘the use of process to learn about an organisations’ own strengths and weaknesses and of other industrial leaders and to incorporate best practice into its operations’ (Camp, 1989). Camp (1989) goes onto described benchmarking as a continual process of measurements of product, services and practices against the toughest competitors’. Three drivers are identified as global competition, breakthrough improvements’ and quality awards. These include Pickering and Chambers (1991), Bititci et al (1997) who talk about the importance of performance measures and have provided a useful model for the ‘closed loop deployment and feed back system to the performance management process’. This is shown in figure 6. Hanson and Voss (1995) have also provided a model which aims to drive organisations towards best practice. This is shown in Figure 7.

BPR is described as an enabler for best practice, this concept is covered in chapter six. The EFQM awards are also described as an enabler.

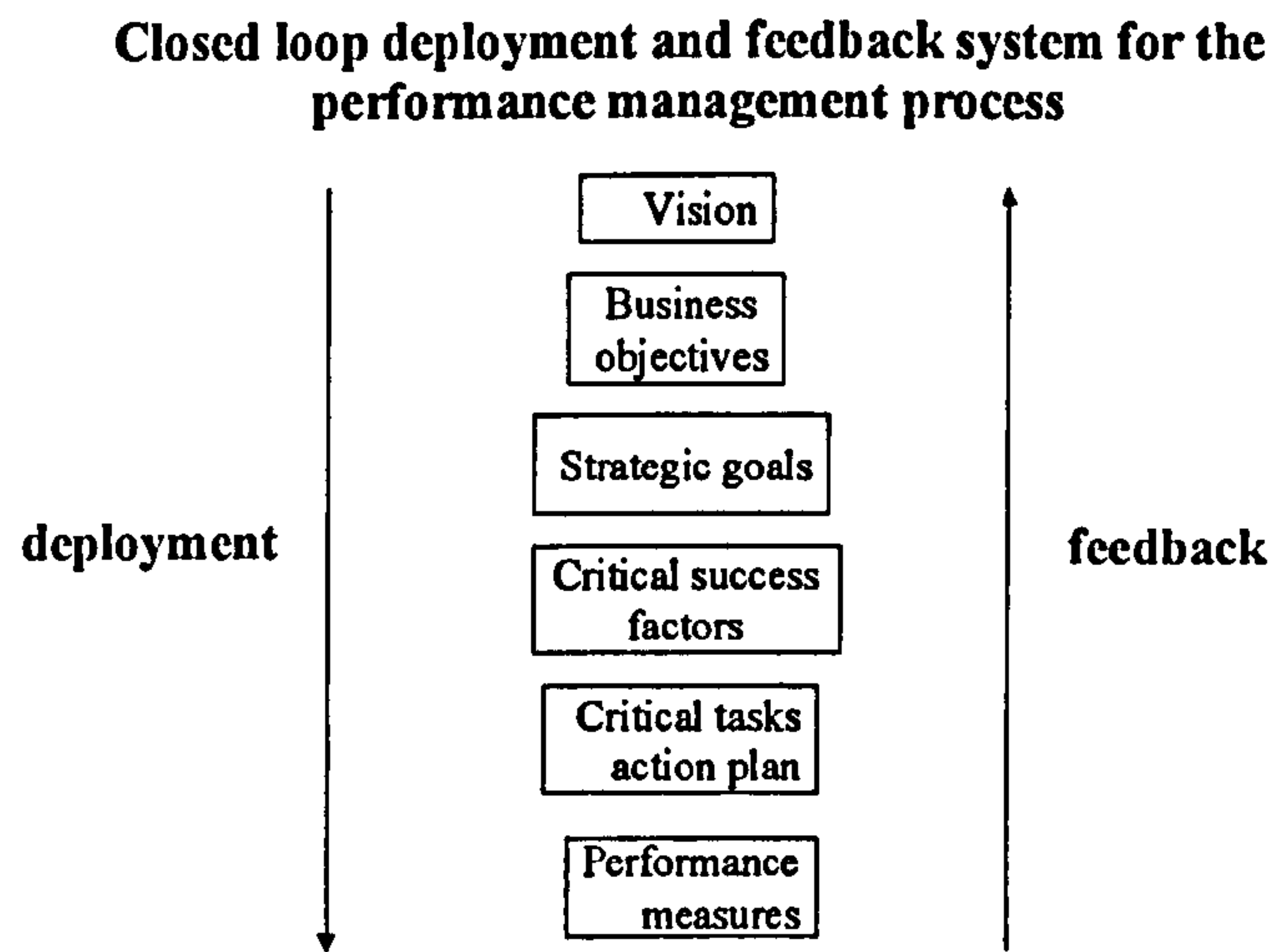

Figure 6 – Closed loop deployment and feedback system for the performance management process (Bititci et al, 1997)

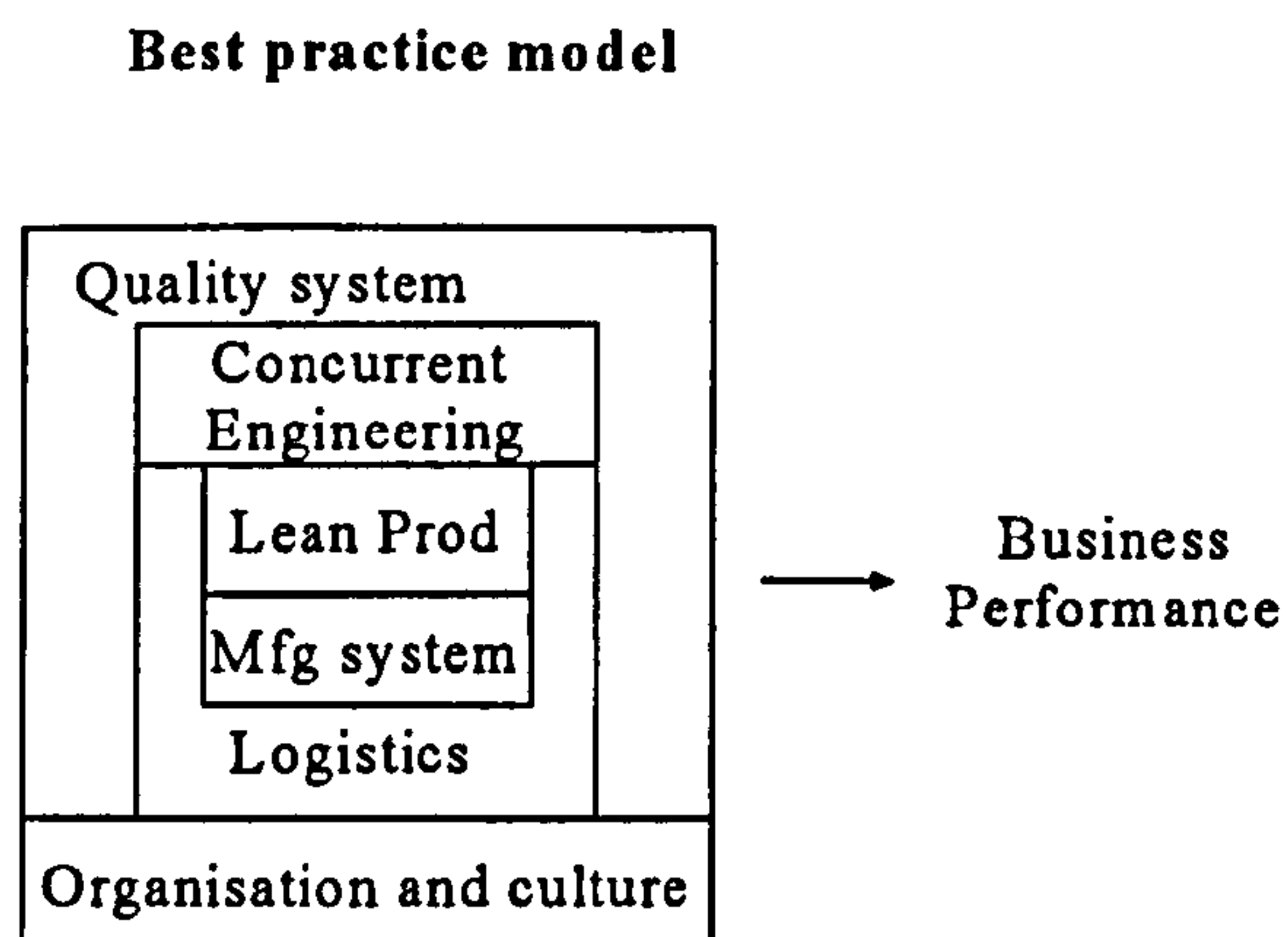

Figure 7 – Best practice model (Hanson and Voss, 1995)

Numerous processes for benchmarking have been developed. Harland (1994) from Rover suggests this approach.

- Establish improvement priorities – what to benchmark
- Identify business processes, measures and benchmarks – how to benchmark
- Set about improvement - closing the gap.

3.9.2.4 Summary of the best practice archetype for manufacturing strategy

The essence of this approach is that continuous identification of ‘best practice’ in all areas in the organisation will lead to superior performance and capability leading to increased competitiveness. According to Schonberger (1996) the most important concept from the above is to ‘manage the process’. However the distinguishing characteristics of the archetype are based on what is working best within the industry at any one time. The decision areas will therefore be in a state of flux depending on what is considered as ‘best practice’. The main methods for achieving best practice are based on benchmarking other organisations and learning from their experiences in similar areas. It is important to note that trade offs are not considered in this archetype due to the philosophy of continuous improvement (CI). These approaches may cross functions and include the whole organisation, which is a wider view than the previous archetype.

3.9.3 The knowledge-based approach to manufacturing strategy

3.9.3.1 Evolution

The evolution of the knowledge-based approach to manufacturing strategy was fuelled by the concept that manufacturing strategy may also look internally at the business in order to identify the organisational core competencies to be able to develop new markets from these core competencies. The view is supported by Long and Vickers-Kock (1996) who talk about the core competencies required to create competitive advantage, Dawes (1995) who talks about using a core competence approach to linking business and operations strategy, and Davis and Botkin (1991) who envisage the coming of the knowledge-based business. Miller and Friesen (1984) support this view by suggesting that companies create their market places and craft their delivery systems.

3.9.3.2 Content of the knowledge-based archetype

The main theme of the knowledge-based approach to manufacturing strategy is the belief that an organisation can not achieve competitive advantage by replicating the success of its competitors, and should concentrate on what manufacturing does well and develop new markets around these competencies (Hayes and Pisano, 1994).

A core competence is something that an organisation does well which has evolved over a period of time. Prahalad and Hamel (1990) have defined core competencies as

'The collective learning in the organisation especially how to co-ordinate diverse production skills and integrate multiple streams of technologies'.

Competitive advantage will rest in the possession of unique, difficult to imitate skills, knowledge, resources, and competencies. The manufacturing organisation may use the development of core competencies as a strategic decision to develop a specific

competence and to cease developing others. This may include developing new technologies or subcontracting out work, which may require new technology development (Probert et al, 1993).

These core competencies may be exploited to move the organisation in different directions with regards to developing markets. This archetype has been described as the 'inside-out' approach (Whittle et al, 1994) to manufacturing strategy or the "knowledge-based" view of the organisation. 'Inside-out' (as opposed to 'outside-in') looks at the core competencies that make the manufacturing organisation successful. These core competencies are then developed and thought is applied as to the development or entry into new markets using these core competencies.

The 'inside-out' viewpoint has been described as developing core technologies and knowledge that are difficult for competitors to duplicate in order to become market leaders, or 'firm specific assets'. Prahalad and Hamel (1994) have explored the concept of competing on capabilities, but further work specifically based around the manufacturing sector would help to clarify how organisations can develop their manufacturing core competencies in order to develop new markets.

Research carried out by Martin et al (1994) and Teece, Pisano and Shuen (1997) has shown that this archetype '*is not well articulated*'. They continue with

'As an emergent way of thinking, capability-led manufacture has not yet achieved paradigmatic neatness...it requires the reinstatement of strategy making as a creative, future oriented and entrepreneurial activity framing experience, know how and assets in new ways.'

Stalk et al (1992) defines capabilities based competition as:

'the ability to emphasise behaviour' looking at the 'organisational practices and business processes in which capabilities are rooted'.

Organisations may benefit from being able to learn from past mistakes and to evolve into an organisation that thrives on knowledge and skills to enable the organisation to determine its own markets.

The behaviours, policies, plans and values associated with this approach are based around the identification, development and nurturing of specific manufacturing core competencies which will give the organisation a competitive advantage.

Tranfield and Smith (1998) suggest that a core competence should be one of organisational learning. The concept of the 'Learning Organisation' which was developed by Argyris and Schon (1978) and Argyris (1992) may be useful to consider when defining the 'paradigmatic neatness' of this archetype. The learning organisation approach has recently been brought to the forefront by Senge (1990) and has been described as:

'The continuous testing of experience, and the transformation of that experience into knowledge - accessible to the whole organisation, and relevant to its core purpose'

The learning organisation understands the fundamental importance of teamworking, individual skills and knowledge, the importance of creativity and the building of the knowledge-based organisation. The competitive edge provided by such an approach also encompasses which organisations can learn and adapt the fastest and bring in new products and services derived from the organisation's knowledge to the market place.

3.9.3.3 Process of the knowledge-based archetype for Manufacturing

Strategy

The processes associated with the development of manufacturing strategy along the archetype of developing core competencies and the learning organisation are still in the

development phase. Research is ongoing into the development of the archetype such as the Themes grant held by Tranfield and Smith (1998).

A model developed by Long and Vickers-Koch (1996) is shown in Figure 8. They talk about the core competencies which are the special knowledge, skills and technology which distinguish the organisation from any other plus the strategic processes which are the business processes used to delivery the special know how. The special know how equals a core capability.

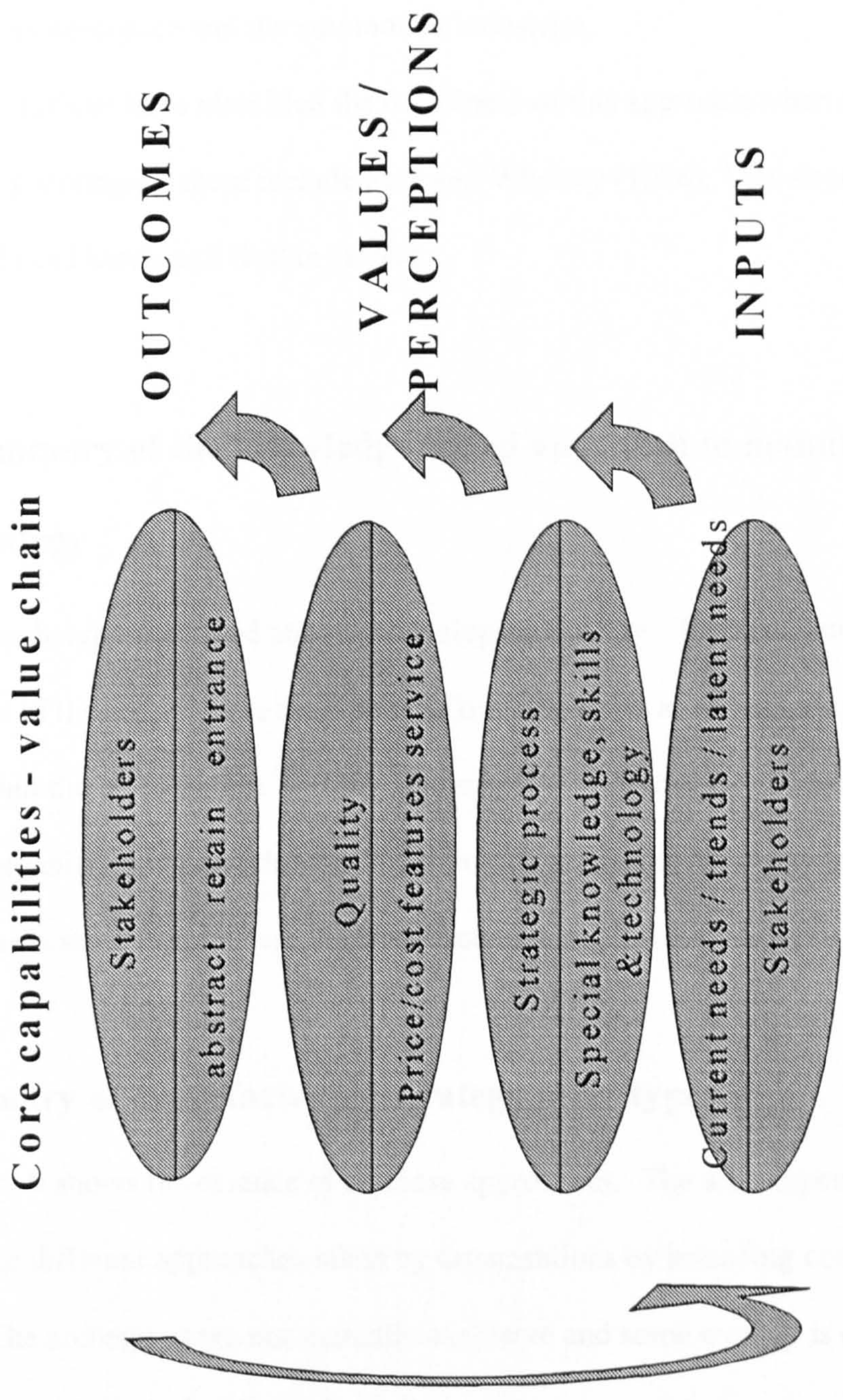

Figure 8 – Core capabilities value chain (Long and Vickers – Kock, 1996)

The identification of the importance of core competencies and the need to identify, develop and nurture core competencies has been recognised by numerous industrial sectors, such as aerospace and the automotive industries.

Other authors have identified the usefulness of this approach when developing manufacturing strategies, these include Fine and Whitney (1996), Cleveland et al (1989), Dawes (1995) and Davis and Botkin (1991).

3.9.3.4 Summary of the knowledge-based approach to manufacturing strategy

The archetype described above is developing quickly. The predominant characteristic of the archetype is the emphasis on knowledge as an important and critical resource within the organisation. Within Hayes and Wheelwright's Four stage model (1984), the organisation taking this type of approach to manufacturing strategy would be moving towards stage Four, where the manufacturing capabilities shape business strategy.

3.10 Summary of manufacturing strategy archetypes

Figure 9 shows the essence of all these approaches. The archetypes are useful in describing the different approaches taken by organisations by bounding content and processes. The archetypes are not mutually exclusive and some overlap is expected. However it could be beneficial to pull all the useful aspects of each archetype into a meta manufacturing strategy model.

Framework for current Manufacturing Strategy Archetypes

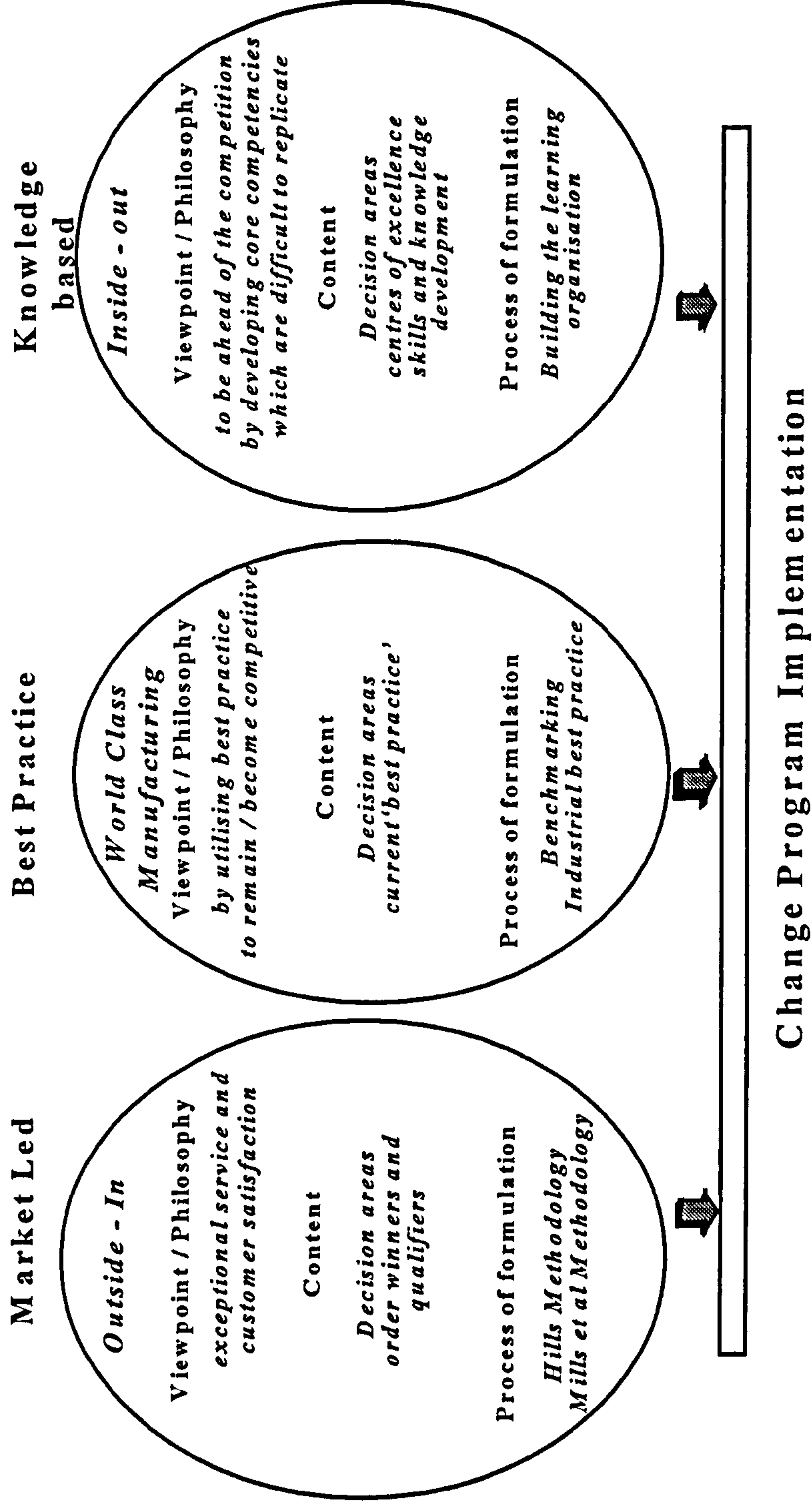

Figure 9 – Manufacturing Strategy Archetypes Framework

The differences between the archetypes are shown in figure 9 and are developed further in Chapter Seven, Eight and Nine using systems thinking and systems concepts into manufacturing strategy-making systems.

3.11 The hard systems approach to manufacturing strategy

The majority of models such as Hill (1985) and Mills (1995) describing manufacturing strategy appear to be based on hard systems thinking, which will be explained fully in Chapter Six. In the majority of methods, the objective is assumed to be clear and the practitioner follows systematic steps, which the practitioner assumes will provide a coherent and usable manufacturing strategy. Only one world view is taken into account when developing the strategy and the models do not appear to take into account the 'softer' issues which are critical to the successful implementation of any manufacturing strategy. The approaches appear to be very rational and planned. This is important as the concepts of viewpoints and whether the approaches taken by the initial case companies are considered during the analysis of the initial empirical data.

However several issues which fall out of the manufacturing strategy formulation process are people - and culture related and can be described as 'messy' and 'ill defined'. These issues are difficult to address using typically systematic engineering methodologies as described by Checkland et al (1984).

The problem of how to improve the competitiveness of manufacturing can be viewed as a 'problem situation' which could be seen from numerous viewpoints of the key stakeholders within a business. For example a marketing professional may have a different perspective on what manufacturing should deliver compared to a manufacturing engineer within the same organisation.

It appears that most models of manufacturing strategy formulation are based on the assumption that a systematic method with one viewpoint expressed, is useful in developing

a manufacturing strategy. This view and other options will be examined in subsequent chapters.

3.12 Discussion

The view that competitive advantage comes from responding to the external environment and by aligning products and processes to 'generic external criteria' has been effective in improving manufacturing. However Hayes and Pisano (1994) argue that

'Simply improving manufacturing ...is not a strategy for using manufacturing to achieve competitive advantage'.

The thinking behind this statement is that you do not achieve competitive advantage by being as good as the best in class. The concept of capability led manufacture or inside-out strategy is a different way of looking at using manufacturing as a competitive weapon.

The emergence of the extended enterprise (Childe, 1998) has reiterated the need for integration of these ideas. This is supported by Platts (1995) who recommends an integrated strategic approach for manufacturing, Morita and Flynn (1997) who support the systems view of manufacturing strategy and Vinodrai et al (1997) who talk about the manufacturing enterprise of the future organised around business processes.

The current literature does not appear to provide the practitioner with further insight into the strands of manufacturing strategy and it is the authors view that developing three archetypes into manufacturing strategy-making systems will provide the practitioner with further insights into the different approaches that are available to them.

The following chapter introduces the initial empirical cases, which are used to develop the research questions.

4 Chapter Four - Empirical Analysis (Phase One)

The preceding chapter introduced manufacturing strategy as a powerful concept to enable organisations to use their manufacturing capabilities to support business strategy. The current manufacturing strategy literature was presented and indicated the importance of manufacturing strategy in developing the competitiveness of the UK aerospace industry.

This chapter introduces the first phase of the empirical research, which consisted of three initial case studies into the use of current manufacturing strategy methods within the UK aerospace industry. The initial empirical evidence provides the foundation for the remainder of the research. The cases portray the organisations' views and approaches to the process of manufacturing strategy formulation.

4.1 Introduction

The chapter has the following objectives:

- To explore the use of manufacturing strategy within the industrial context.
- To collect and analyse empirical data derived from experiences of the UK aerospace industry using manufacturing as a competitive enabler to determine what methods were being used and if these methods were useful to the practitioner.
- To provide a basis for further empirical research within the UK aerospace industry.
- To determine whether companies fall into any of the archetypes identified in Chapter Three.

The focus of the chapter is to provide the initial empirical data concerning evidence of UK aerospace organisations' use of current manufacturing strategy methods. The

method of obtaining the empirical data consisted of interviews, company visits, use of company documentation and triangulation. Meredith et al's (1989) research method of description, explanation and testing was used in the initial research as follows:

- Chapters Two described the aerospace industries current issues.
- Chapter Three explained the potential use of manufacturing strategy concepts to address those issues.
- Chapter Four tests the use of the frames and theories described in Chapter Three to determine whether opportunities for improvement can be identified to address the issues facing the industry.

The initial phase of the research was carried out in the period 1995 to 1996. The objectives of this phase were to test the initial ideas derived from the manufacturing strategy literature and to discuss the methods with practitioners. It was decided to determine whether UK aerospace organisations' use of manufacturing strategy matched the concepts and methods portrayed in the POM literature. From this, the research could develop its focus and research question set in order to make a useful contribution to the field.

Objective Three of the initial research was to 'determine the methods used within the UK aerospace industry'. Carrying out three initial case studies into the experiences of three UK aerospace companies completed this objective.

4.2 Initial case study framework

The design of the initial case studies was developed from Platts and Gregory (1989) and the work done on the process of formulated manufacturing strategy by the Cambridge Manufacturing Engineering Research Group. The following criteria were presented as

being useful when researching Manufacturing Strategy: *Point of entry, participation, procedure, and project management*. A full description of the criteria is included in Chapter Three - Manufacturing Strategy. These criteria were examined, investigated and verified with general questions on organisation structure, the evolution of the manufacturing organisation, and core business processes (if the organisation was a process-focussed organisation).

4.3 Case study research plan

The following case study research plan was sent out to the three initial case organisations. The plan outlined the general objectives of the research and identified what would be covered at the company visits. The objectives were:

1. To identify the current techniques and concepts used in the formulation of manufacturing strategy.
2. To determine the methods used within the UK aerospace industry - including both prime contractors and suppliers.

The case studies include the following

- General background to the manufacturing organisation
- General issues concerning the manufacturing strategy process
- An examination of the process of manufacturing strategy formulation within the organisation, looking at how corporate and business objectives affect the manufacturing strategy chosen. Focusing on the following: The point of entry - when and if manufacturing was identified as a competitive asset. Participation - the different functions involved in the formulation process. Procedure - the actual process used and Project management - the timescales and resources involved.

- Change programmes within the manufacturing organisation
- To determine whether a market led / customer focussed, best practice or knowledge-based manufacturing strategy making process (or a hybrid) is followed (Platts and Gregory, 1989).

4.4 Conducting the case studies

Three organisations provided data through open ended and structured interviews with key manufacturing stakeholders, focus groups and work placements. Talking to people at different levels in the organisational hierarchy enriched the data. Generally, the author was given access to the Manufacturing or Operations Director, Manufacturing Managers, and Manufacturing Engineers. Other sources of data included the use of the Internet, company reports, video and public domain material.

4.5 Initial case Studies

4.5.1 Themes

The case studies were analysed for the following themes.

- **Point of entry** – what triggered the interest in manufacturing strategy methods, if any?
- **Process** – was any formal process in place to help and enable the strategist or operations manager to make best use of the current manufacturing strategy methods?
Was the process planned or emergent?
- **Participation** – who participated in the process within the organisation?
- **Archetypes** – which manufacturing strategy archetype was followed – best practice, market led / customer focussed or the knowledge-based approach?
- **Change programmes** – were companies taking a business process view of organisational change?

- **Hard systems approach** – was the approach taken systematic and based on one worldview of manufacturing?

4.5.2 Summary of the initial case studies

The following is a summary of the key points of interest from the initial case studies. The full cases can be found in Appendix One.

4.5.2.1 Case A

Case A is a prime contractor and systems supplier and sits at the top of the value chain within the UK aerospace industry. At the time of the initial study – March 1995, the organisation was experiencing radical changes in the market place and had suffered financial problems and job losses. The interviewees for the case study were the manufacturing strategy executive, a manufacturing strategist and a manufacturing engineering manager. The role of the manufacturing strategy executive was to co-ordinate manufacturing improvements and to chair an Improvement Forum which encompassed directors from four sites within the organisation. The research method for the case consisted of structure and unstructured interviews. All interviewees were sent a transcript of the interviews to enable validation.

At the time of writing, the decision to shut two sites had been taken. This was the result of the current build programme and current head count. A framework of 2 feeder sites and 2 final assembly sites was implemented.

The interviewees reported that no formal manufacturing strategy existed, although the organisation had a robust business planning cycle that was reviewed on a monthly basis. Key performance indicators (KPI) and critical success factors (CSF) were set for each site, directorate and department. Objectives were then set for employees from the KPI and CSF that were linked to a management of performance system. The key issues

affecting manufacturing was cited as ‘the rate of change of technology’ and being ‘financially driven’.

The point of entry for the organisation to start thinking about manufacturing as a competitive asset was described as ‘due to the change in market condition’, the move to ‘fixed price contracts as opposed to cost plus’ and the ‘cancellation of a large order’.

The participation issue of the business planning cycle consisted of four site directors, the logistics director and the manufacturing strategy executive. Regarding project management, three years was considered short term and consisted of moving labour and work packages around the organisation and five years was considered as the business planning timescale.

The main decision areas considered were performance measures, schedule adherence and statistical process control. The manufacturing philosophies which were being considered at this time included Just in time, lean manufacturing, management of technology and the reduction of lead times. The manufacturing strategy formulation process was described as emergent.

The change programme at this time was called ‘Operational improvement initiative’, which incorporated the philosophies of lean production and world class manufacturing.

4.5.2.2 Case B

Case B is a prime contractor within the UK aerospace industry. At the time of the initial study – March 1995, the organisation had just merged to form a new organisation. The interviewee for the case study was the production strategy executive. The role of the production strategy executive was to form the strategic plan for the operations elements of the newly formed organisation. The research method for the case consisted of a structured interview. The interviewee was sent a transcript of the interview to enable validation.

Due to the timing of the interview the company was under pressure from its parent company to reduce costs. The company had just lost 1400 people and it was reported that it would take a while to recover from the loss of expertise.

The point of entry for the organisation to start to look at manufacturing strategy seriously came due to a change in technologies and in the market place. Participation was solely manufacturing based, and no formal method was in place. The planned approach was to define the strategic architecture, to initiate a programme of continuous improvement and to identify the core competencies of the organisation. The current manufacturing strategy process was emergent in nature.

No change programmes were ongoing due to the merger, however it was planned to follow the lean enterprise model with a project named 'project competitive edge'. Benchmarking was seen as being critical to the process and a move towards a business process focus was favoured.

4.5.2.3 Case C

Case C is a systems and components supplier within the UK aerospace industry. The interviewees for the case study were the manufacturing director, chief engineer, the research and development manager, the manufacturing team leaders, and manufacturing graduates. The research method for the case consisted of structured and unstructured interviews, workshops, meetings and viewing company documents. Due to the longitudinal nature of the study, interviewees were continually validating the material provided.

At the time of writing the case was moving towards a business process focus, resource managers had been appointed and key processes had been identified. These included: finance, personnel, resource management, manufacturing, business development and engineering.

The key issues around manufacturing consisted of investment in new technologies and the development of cellular manufacturing.

At this time the point of entry for the organisation to view manufacturing strategically had not happened. The role of manufacturing was seen as 'support the business in filling and selling the order book'. No formal process was identified but the people involved in thinking about manufacturing strategy included the chief engineer, the research and development manager and the manufacturing team leaders. Any manufacturing strategy was emergent in nature.

4.5.3 Analysis of initial case studies

4.5.3.1 The key issues

The key issues facing the organisations ranged from the rate of change of technology to the pressure to reduce costs and to get the orders out of the door. The industry had just emerged from a recession and the effects were just beginning to filter into the organisations to trigger them to think about manufacturing strategy issues.

4.5.3.2 The manufacturing strategy process

No formal manufacturing strategy process was identified or reported in any of the cases. Any action plans or change programmes which were apparent within the manufacturing organisations at this time were emergent, rather than deliberate.

4.5.3.3 Point of entry

The point of entry for Case A and Case B was the changes in market conditions and the need to respond to those changes. The change from cost plus to fixed price contracts was cited as being critical. Case C did not appear to have reached the point of entry at this

stage, although several of the interviewees certainly realised the benefits of using manufacturing as a competitive tool.

4.5.3.4 Participation– who participated in the process within the organisation

Case A was the only organisation who involved logistics within the emergent process. Case B and Case C reported that only manufacturing personnel were included in any discussions concerning manufacturing strategy.

4.5.3.5 Archetypes

The best practice manufacturing strategy archetype was loosely followed by all cases. Case A was embarking on an operational efficiency improvement programme, Case B was embarking on an improvement program and Case C was implementing cellular manufacturing. The market led / customer focussed approach and knowledge-based approaches were not used in any case, although Case B expressed an intention to identify the core competencies within the organisation.

4.5.3.6 Change programmes

Cases A and B were taking a business processes view of organisational change, whereas Case C was firmly embedding in a functional mindset, even though the case had identified business processes.

4.5.3.7 Hard systems approach

In all three cases, only one view of manufacturing was expressed as being important. Each case appeared to take a systematic approach as opposed to a systemic approach.

4.5.4 Inferences and findings from cases

The case studies provided initial evidence that whilst the theory of manufacturing strategy may be well developed in academia, the needs of the practitioner appear to have moved on from the market led, functional paradigm of manufacturing strategy. The needs of the practitioner now encompass the competence based view of the firm, which was identified as an intention from Case B and the business process focussed view of the firm which was apparent from the change program from Case A. The best practice approach to manufacturing strategy was the only approach visible from the cases presented, and the potential benefits from the market led / customer focussed and knowledge-based approaches had not been realised. No case had a planned process for manufacturing strategy in place, and all cases had an emergent process that was orientated towards the best practice archetype.

The case studies provided initial evidence that the current theory of manufacturing strategy is not widely used. However the interviewees acknowledged the need for a coherent manufacturing strategy.

Case A and B both had major change programmes in progress at the time of the study. Case A was moving towards a process focussed organisation with a major business process re-engineering programme under way. Case B was re-structured six weeks prior to the study and major changes were in the planning stage.

From the above cases, it was concluded that theory does not appear to be in use, for some reason. At this stage propositions were developed that organisations were moving from a functional orientation to a business process focus, and current manufacturing strategy models appeared to be predominantly based on the function. It was also concluded that Hayes and Wheelwright's Four-stage model (1984) was useful in identifying the strategic positioning of manufacturing within an organisation.

4.5.5 Summary of case study results

The initial findings were presented to the 1996 EUROMA Conference in the form of a paper (Greswell et al, 1996) 'The linking of manufacturing strategy to business process re-engineering'. The discussion following the presentation was most useful in directing the second phase of the research and the identification of the need to develop the manufacturing strategy field to incorporate the changing view of manufacturing from a functional orientation to a business process focus. The full case studies are attached as cases A B and C in Appendix One. The results of the initial investigation are summarised in Table 2.

Research Element	Case A	Case B	Case C
<i>Major Customers</i>	Military and Civil	Civil	Military and Civil
<i>Process</i>	Emergent - no formal process	Emergent - no formal process	Emergent - no formal process
<i>Point of Entry</i>	Peace dividend - the change from cost plus to fixed price	Change in market and technology	Still needed. Interviewee saw the need for a manufacturing strategy- senior management still to be convinced
<i>Participation</i>	Site Directors Manufacturing Directors Logistics Director Manufacturing Strategy Executive	Engineering Strategy Executive	Manufacturing Director Chief Engineer Manufacturing Team Leaders Supervisors
<i>Hayes and Wheelwright Four stage model</i>	2-3 externally neutral to internally supportive	3-4 internally supportive to externally supportive	1-2 Internally neutral to internally supportive
<i>Market led, best practice or knowledge-based</i>	Mostly best practice	Planned to use combination of the market led and knowledge-based approach	Mostly best practice approach
<i>Change programme business process focussed</i>	Major BPR programme initiated at time of initial case.	Not yet defined at time of initial case.	Not at time of initial case, however a business process focus was being considered

Table 2 Summary of initial case study analysis

The full cases show that current manufacturing strategy methods were not widely used within the three initial case organisations. The findings from the initial case studies led to the development of the research question set and research programme which is described in the following chapter – Chapter Five – Research Methodology.

5 Chapter Five - Research Methodology

Chapters Two, Three and Four have provided the initial foundation for the research and have provided a focus for the research questions. This chapter describes the research methods literature that helped to form the research methodology used to progress the research.

5.1 Objectives of chapter

The objectives of this chapter are to evaluate current research methods available to researchers within the POM domain and to identify suitable research strategies and tools to ensure the output of this research is useful to POM practitioners.

5.2 The objective of the research

The objectives of the research are:

1. To critically review current manufacturing strategy literature, which was carried out in Chapter Three.
2. To determine if manufacturing strategy methods and techniques are currently used within the UK aerospace industry, (this was initially carried out in Chapter Four to determine if the research was useful.)
3. To identify opportunities for improvement to current manufacturing strategy methods.
4. To develop a useful tool to address any findings derived from the research.

The research has focussed on theory generation in order to:

- develop ideas and concepts that are useful to operations management practitioners (Thomas and Tymon, 1982),

- progress manufacturing strategy's theoretical base which was identified as important by Platts (1993), and
- provide an enabler for an aerospace organisation's move towards a systemic view of strategy formulation which would benefit a business process architecture.

The research identified the UK aerospace industry as a suitable research area due to the following considerations:

1. The industry has changed in the past decade because of several factors. These factors include, changes in the boundaries of Europe, the peace dividend, customer procurement policy changes, the cost of developing new products and subsequent collaboration, and globalisation (Hesford, 1997). These factors were discussed in Chapter Two.
2. The manufacturing element within the industry is crucial to the economic success of the UK economy and has been included as a major part of the Engineering and Physical Sciences Engineering Council's Innovative Manufacturing Initiative (IMI, 1996).
3. Several aerospace companies have embarked on business process re-engineering programmes and are becoming increasingly process focussed with a consequent blurring of functions. This was described in Chapter Four.

These considerations were discussed in Chapter Three – the challenges facing the UK aerospace industry and the manufacturing role in meeting those challenges.

5.3 Evolution of the research methodology

The research methodology has evolved from several sources, which have included Meredith et al's (1989) research cycle and strategy literature, the needs of the practitioner,

and empirical theory generation using case study research methods. These sources will be explored in the context of Production and Operations Management (POM) research needs and will be summarised as POM research requirements. The research methods used in this research program will then be presented.

5.3.1 The Research Cycle

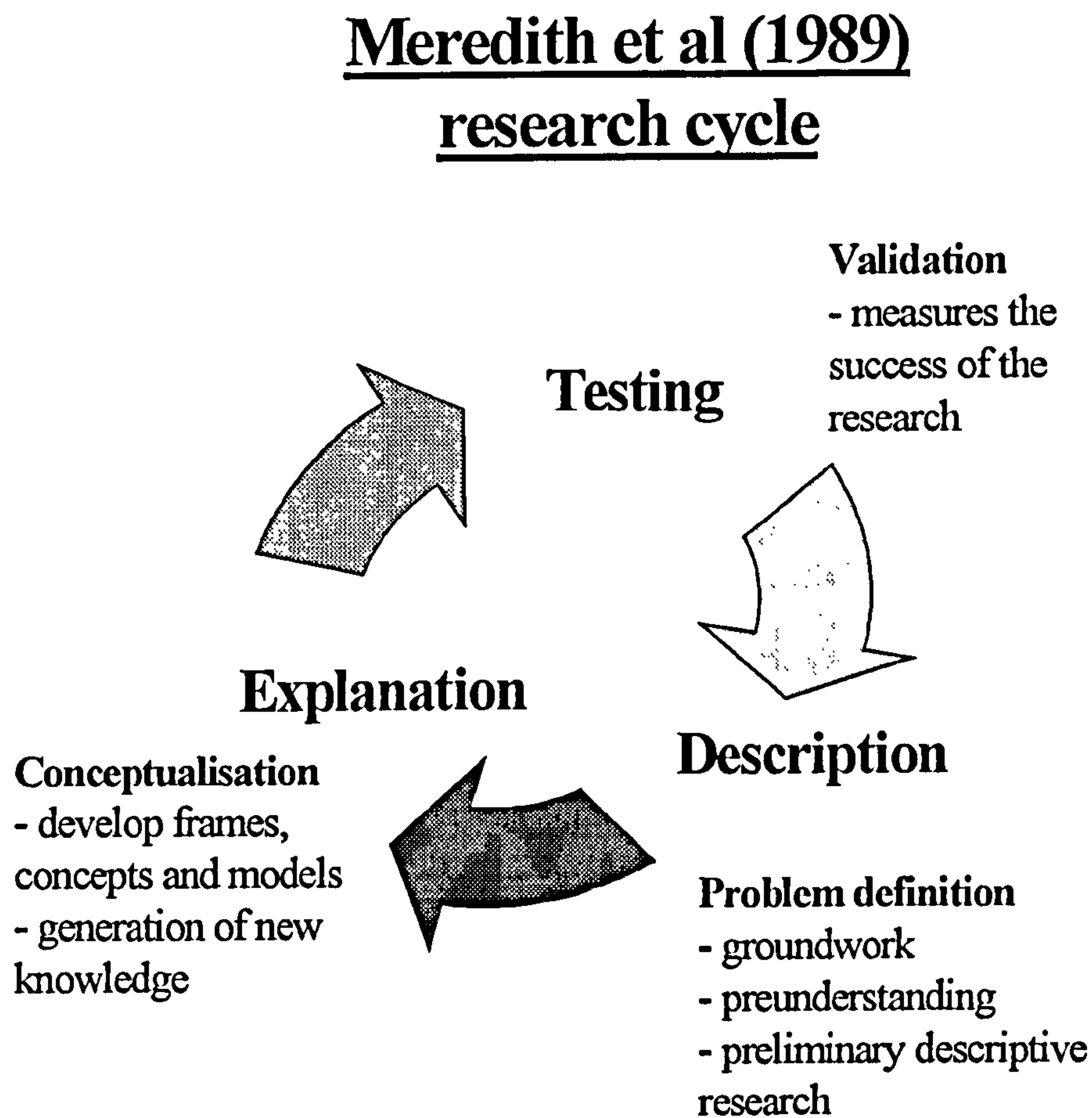

Figure 10 – Meredith et al (1989) Research Cycle

The research cycle is described as a continuing cycle of description, explanation, and testing, with each phase generating new learning and knowledge.

The description phase can also be described as the problem definition phase. This provides the groundwork and focusing of the research and should enable the researcher to

refine the research question set and focus in on the chosen research area. This phase seeks to address the preunderstanding of the researcher and current literature available. This enables the researcher to build up a picture of the phenomenon being studied. The phase can also be described as the 'preliminary descriptive research' (Filippini, 1997).

The explanation phase has also been described as the conceptualisation phase. This provides the opportunity to develop frames, concepts, and models to attempt to make sense of and explain the phenomenon under investigation. The result of this phase may take the form of the generation of new knowledge. This new knowledge may be expressed as conceptual models and / or frameworks, as described by Meredith et al (1989), which justify the relationships between variables (Filippini, 1997).

The testing phase can be described as the validation of the new knowledge developed in the explanation phase. The phase is used to measure the success of the research in meeting the research objectives and subsequently answering the research questions. In this phase, any new knowledge is refined and developed if necessary by restarting the cycle with a modified problem definition (Meredith et al, 1989)

This cycle was used in Phase One of the research to ensure a firm foundation was provided to develop the research questions and subsequent research methods. The research methodology evolved further following the identification of Checkland and Scholes (1990) Soft Systems Methodology (SSM) as a suitable research tool. SSM was developed as a systemic and general approach to problem solving using alternative methods to those generally used in systems engineering, such as stating what the problem is at the start and having key set objectives in order to develop a solution. The approach can be seen as cycles of learning and will be described fully in Chapter Six.

5.3.2 The needs of the Production and Operations Management practitioner

The research project has been placed in the Production and Operations Management field, which has been defined as ‘a discipline which is concerned with the selection, adaptation and management of new technology and socio-technical systems’ (Filippini, 1997). When discussing each influence on the development of the research methods chosen, it is important to determine whether the research has provided a contribution to the field of POM. The successful contribution of this research will be measured through the usefulness of the research output to practitioners as described by Thomas and Tymon (1982). It is also useful to consider the problems that have been identified within the area of POM research as identified by Feurer and Chaharbaghi (1995), Westbrook (1995), Meredith (1993) and Platts (1993). POM research is reported to have a lack of theory development and systematic empirical research. Empirical research and the use of case studies have been identified as useful approaches to enable a holistic approach to POM research (Westbrook 1995).

The research is aimed at helping practitioners to gain a greater understanding of both the theory and practicalities behind current manufacturing strategy methods. The research output aims to provide the practitioner with an approach, which should enable them to formulate a feasible and implementable manufacturing strategy. Thomas and Tymon (1982) have identified a framework that identifies the needs of the practitioner. They suggest that any useful POM research should include the following: Descriptive relevance, goal relevance, operational validity, non-obviousness, and timeliness. These aspects will be used to determine if the research output are useful and should be seen as validating aspects of the research.

Descriptive relevance describes how well the new knowledge / contribution can be used in a particular context. This reinforces Campbell and Stanley’s earlier work (1965)

into external validity. To measure descriptive relevance / external validity, the researcher must consider how general the contribution to knowledge is, for example, can the new knowledge be used in specific or general areas of industry. In the context of this research project the contribution to knowledge should be applicable to the UK aerospace industry in particular, but also to organisations which have a business process focus.

Focus groups and interviews were used to ensure descriptive relevance, and the comments are included in Appendix Four. At the validation workshops, the practitioners felt that the approach would be beneficial to other sectors of industry as well as the aerospace sector. The use of the modified approach to developing a manufacturing strategy could be transferred to operations in other manufacturing areas and service sectors.

Goal relevance describes and assesses how easily and successfully the practitioners can absorb and use the contribution to knowledge to help to achieve their current objectives. For example is it relevant to them? This will be measured through the validation of the approach, which has been developed to make the research output accessible, and in a usable format through a facilitated workbook. The output of the research is a systems approach to the formulation of a manufacturing strategy using a workbook and facilitator as the delivery mechanism with an emphasis on soft systems principles. The approach was validated by two aerospace organisations and one Small to Medium sized Enterprise. The results of the development and validation of the approach are covered in Chapter Eleven.

Operational validity assesses how easy it is to use and implement new knowledge created. This aspect was incorporated as described above and the approach continues to be tested in more organisations with the use of a facilitator to determine opportunities for improvement to the approach.

Non obviousness questions the 'meaningfulness' of the research. In this research, the output aims to provide an alternative approach to developing a manufacturing strategy

which takes into account different worldviews of the manufacturing key stakeholders and taking a systems approach using soft systems principles (Rhodes, 1985).

Timeliness questions the applicability of new knowledge at a particular point in time for example when will the research be applicable. The new knowledge should be useful to the practitioner at the time of generation. The research has taken into consideration the current changes within the industry and the effect of the move to a business process focus when developing the modified approach.

Using the above framework as a guide, the research output (results) from this research project should:

- be useful for both process focussed and aerospace organisations when formulating manufacturing strategies in the future
- enable the practitioner to use the models and frames of three manufacturing strategy-making systems to develop their learning and the development of their manufacturing strategy formulation process
- be straight forward, easy to understand and use with the help of a facilitator
- facilitate the development and implementation of a manufacturing strategy, which supports corporate objectives and improves competitiveness through manufacturing.

Bearing in mind that the focus of the research is on the usefulness of manufacturing strategy formulation, the following research framework design considerations have been presented by Feurer and Chaharbaghi (1995).

- 1 The research should analyse strategy formulation in a holistic way to include strategic as well as operational issues.
- 2 The framework developed should be able to incorporate current strategic knowledge.

3 The research findings should be relevant to organisations operating in dynamic environments.

4 The research should present a continuous learning process to accommodate emerging issues.

The research method has evolved not only from the needs of the practitioner but also from the research methodology literature. These 'needs' will be revisited in Chapter Twelve - conclusion and discussion.

5.3.3 Research methods and strategies

Once the research question has been set, the objectives and the needs of the POM practitioners have been considered, the relevant method for progressing that research must be developed. The evolving research method depends on several stimuli as mentioned previously, however other factors should be considered during the development and design of the research method to ensure it is valid.

Gummesson (1991, 1993) has identified several criteria that may be useful in determining suitable methods for a specific research project and a specific researcher.

The scientific paradigm of the researcher should be considered, as this will have a considerable bearing on the methods chosen for the research. The scientific paradigm has been described by Gummesson (1991) as 'the artefacts, values and taken for granted' the researcher holds. Although it is very difficult for a researcher to articulate which paradigm they sit in, until a paradigm shift occurs it must be considered as part of the pre-understanding that the researcher brings to the project.

Access to reality must be carefully considered. As the research question set has focussed on the process of manufacturing strategy formulation it will be important to get close to reality by looking at multiple sources of data and talking to the key practitioners involved. This has been addressed by looking at a range of organisations within the

aerospace supply chain from prime contractors to components suppliers and by talking to the interviewees with differing roles ranging from manufacturing directors to manufacturing team leaders.

Data generation is a simultaneous process of choice and interpretation (Glaser et al, 1967), giving the data basis for theory generation. Qualitative data can be used in the generation of concepts, properties, categories, models and management theories (Gummesson 1991 and 1993, Jick 1979, Denzin and Lincoln 1994). In this research, data has been generated through open-ended interviews, observations and documentation from the case organisations and the Internet, and developed into concepts and models through discussions with practitioners and academics.

Generalisability, theoretical sampling, and saturation - The number of cases studied was determined by the saturation point, that is when further cases will add little to understanding, and also by the access and availability of relevant personnel. This is addressed by collecting data from three organisations for Phase One and seven for Phase Two. This may not be complete saturation, but provided a rich source of data to enable inferences to be made for the UK aerospace industry. The above criteria will be used to validate the research and will be discussed in Chapter Twelve.

The evolution of the research methodology has taken into consideration the needs of the practitioner identified by Thomas and Tymon (1982), the criteria identified by Gummesson (1991) for determining suitable research methods. The next stage in the research methodology development identified the need for case study research. The UK aerospace industry was chosen as the environment in which the research would take place because of the importance of the industry to the UK economy and the contacts and preunderstanding of the author.

5.3.4 Case studies as a research tool

It was decided to develop the research using case studies because of their usefulness in building up a rich picture of the problem situation. This has been defined as how UK aerospace organisations can use their manufacturing operations to become competitive. The method is best suited to '*how*' and '*why*' questions and '*on focusing on contemporary events*' (Yin, 1994). The method is also suitable for developing a pertinent hypothesis prior to testing, propositions for further study and for carrying out exploratory research.

Yin (1994) has developed a useful framework for testing the quality of the design of case study research. This framework includes construct validity, internal validity, external validity and reliability.

Construct validity establishes the correct operational measures for the concepts being studied. This is addressed by using multiple sources of evidence, establishing a chain of evidence and by ensuring key informants review draft case study reports. This has been addressed by ensuring all interviewees received a copy of their interview transcripts. This enabled them to validate the data they initially provided.

Internal validity establishes a causal relationship, whereby certain conditions are shown to lead to other conditions and describes what can be inferred from the relationships identified. This has been built in by comparing aerospace experiences with the current literature, and by exploring the evolution of organisations and their use, or not, of manufacturing strategy principles and methods.

External validity establishes the domain to which a study can be generalised. This has been incorporated by using the aerospace industry and various cases within the supply chain, and by testing the modified approach in several organisations.

Reliability demonstrates that the data collection procedures can be repeated with the same results. This has been built in by using a structured open ended question set for each case study which is included in Appendix Two. It is believed that similar results would be seen with a different researcher.

Westbrook (1995) reiterates the need for POM researchers to address problems which are 'messy', interrelated across organisations, and supports the view that case study research can be useful in this area.

5.4 Research requirements for the POM practitioner.

After considering the development and design of the research method, the requirements for production and operations management research should also be evaluated. The research methodology chosen should take in to account the preunderstanding of the researcher and ensure the researcher has sufficient access to be able to build a picture of the perceived reality (Gummesson, 1991). The identification of the aerospace industry due to the contacts and preunderstanding of the author has addressed this. The research methodology should incorporate cycles of learning which allow insights and unexpected outcomes to emerge in a recognised framework of knowledge generation (Meredith, 1993). This has been addressed by incorporating Checkland and Scholes' (1990) soft systems methodology as three cycles of learning. This is supported by Feurer and Chaharbaghi (1995) who advocate learning cycles when researching strategy formulation.

The research output should meet the needs of the practitioner as identified by Thomas and Tymon (1982), and should make a contribution to production and operations management research. The preceding paragraphs have introduced the specific research objectives and given a basic grounding in the issues that should be addressed when designing and carrying out a research programme. The remaining sections of the chapter will describe the main research activities undertaken.

5.5 The research methodology used in this research programme

A methodology can be defined as ‘ set of principles of method’ (Checkland, 1981) therefore the research methodology for this research project has been developed from the set of principles described above. The evolution of the thinking, which developed the methodology, has been linked with the set of principles and techniques underpinning the research.

The research can be split into two distinct phases. The first phase used Meredith’s cycle of description, explanation, and testing and is presented in Chapter Four. The second phase developed Meredith’s cycle by using systems concepts and Checkland’s’ (1990) Soft Systems Methodology as a structure on which to base the learning of the research and to use the principles of the methodology to develop new knowledge.

5.5.1 Phase One

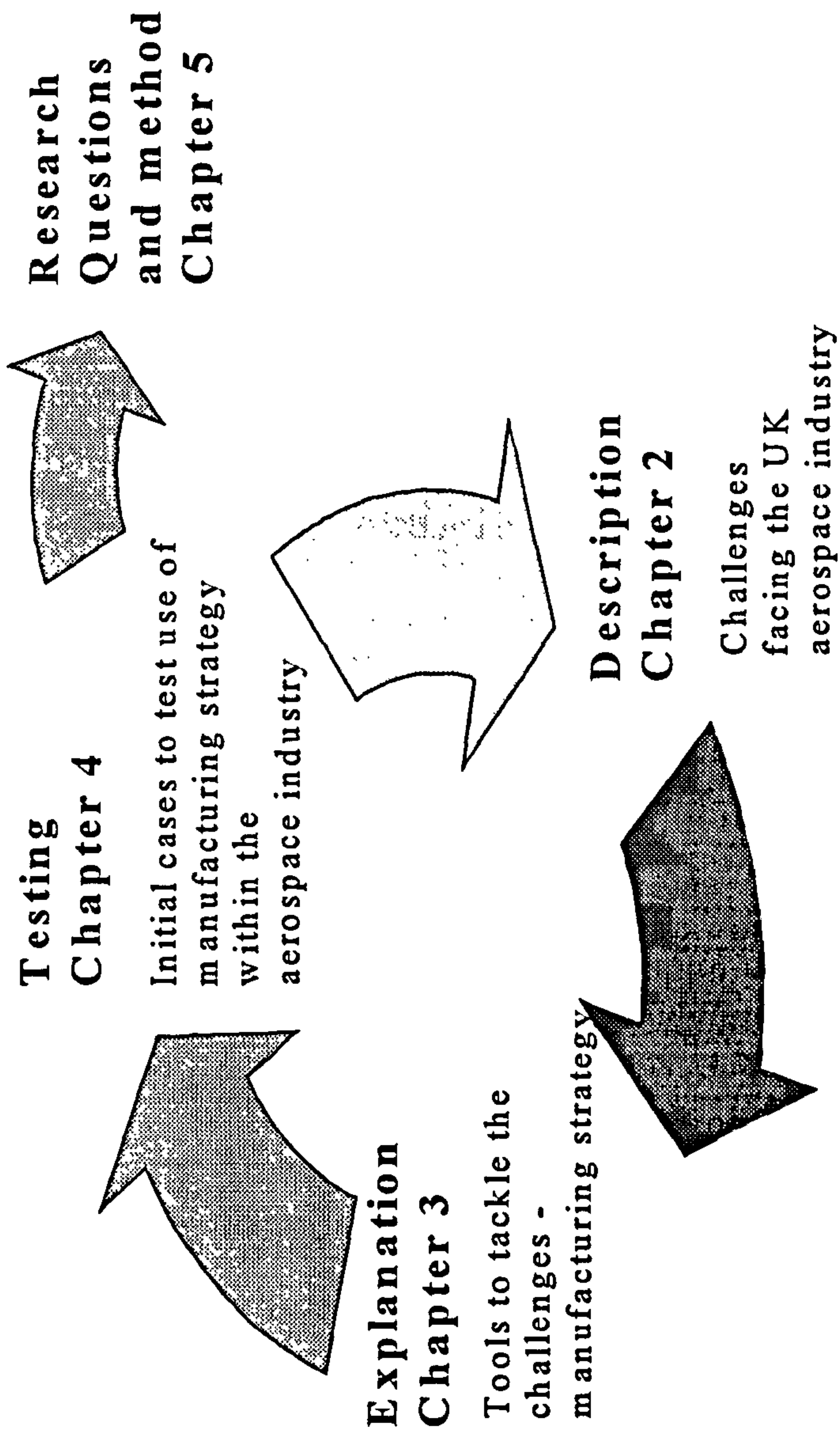

Figure 11 – Phase One – Meredith et al (1989) research cycle

5.5.1.1 Description (problem definition).

The research was initiated with a perceived general problem situation surrounding the issues and challenges facing the aerospace industry. The objective of this phase was to address the preunderstanding issues and current literature to enable the research to focus and develop a set of research questions and objectives. The aerospace industry was explored and the summary is presented in Chapter Two. The problem definition at this stage was what tools and techniques can be used to enable the UK aerospace industry become and or remain competitive.

5.5.1.2 Explanation (conceptualisation).

The explanation phase of the research identified and reviewed several manufacturing strategy frameworks that were useful to practitioners. A literature review was carried out to identify current thinking and practice of manufacturing strategy including content and process, systems theory that encompassed both soft systems and hard systems thinking, and the evolution of manufacturing within the UK aerospace industry. This literature review was presented in Chapter Three.

5.5.1.3 Testing (validation)

The testing element of phase one consisted of analysing the three case studies developed in Chapter Four. The concepts and models identified in the explanation element were used to classify the initial case organisations and to make sense of the data in the context of the current theory. The results of the cases led the researcher to focus on whether current manufacturing strategy methods were suitable for aerospace companies evolving into a more process focussed as opposed to functional organisations and the use

of concurrent teams. These ideas were refined and developed for Phase Two of the research.

5.5.1.4 Summary of Phase One

The activities undertaken during Phase One were used to gain an understanding of the area under study. This was done by building up a base of current literature and understanding the issues involved in the UK aerospace industry concerning the formulation of manufacturing strategy. The literature was then assessed critically to determine whether current models appeared to be appropriate for the evolving UK aerospace industry which included a growing number of business process focussed organisations using concurrent engineering teams.

5.5.2 Phase Two

Phase Two of the research is presented in the remaining chapters and used a modified approach to the research method by incorporating the cycles of description, explanation and testing into the structure of SSM. The approach is described in detail in Chapter Six and used in Chapters Seven to Eleven. The methodology developed consisted of three cycles of learning using systems concepts to clarify and bound the phenomena under investigation.

- Cycle One (Chapters' Seven, Eight and Nine) developed three manufacturing strategy-making systems using systems concepts from the identification of three manufacturing strategy archetypes (Whittle et al, 1994).
- Cycle Two developed seven empirical studies in systems terms, which enabled a comparison with the manufacturing strategy making systems which can be found in Chapter Ten.

- Cycle Three incorporates the findings of the previous two cycles into a modified approach to the formulation of a manufacturing strategy, which is described in Chapter Eleven.

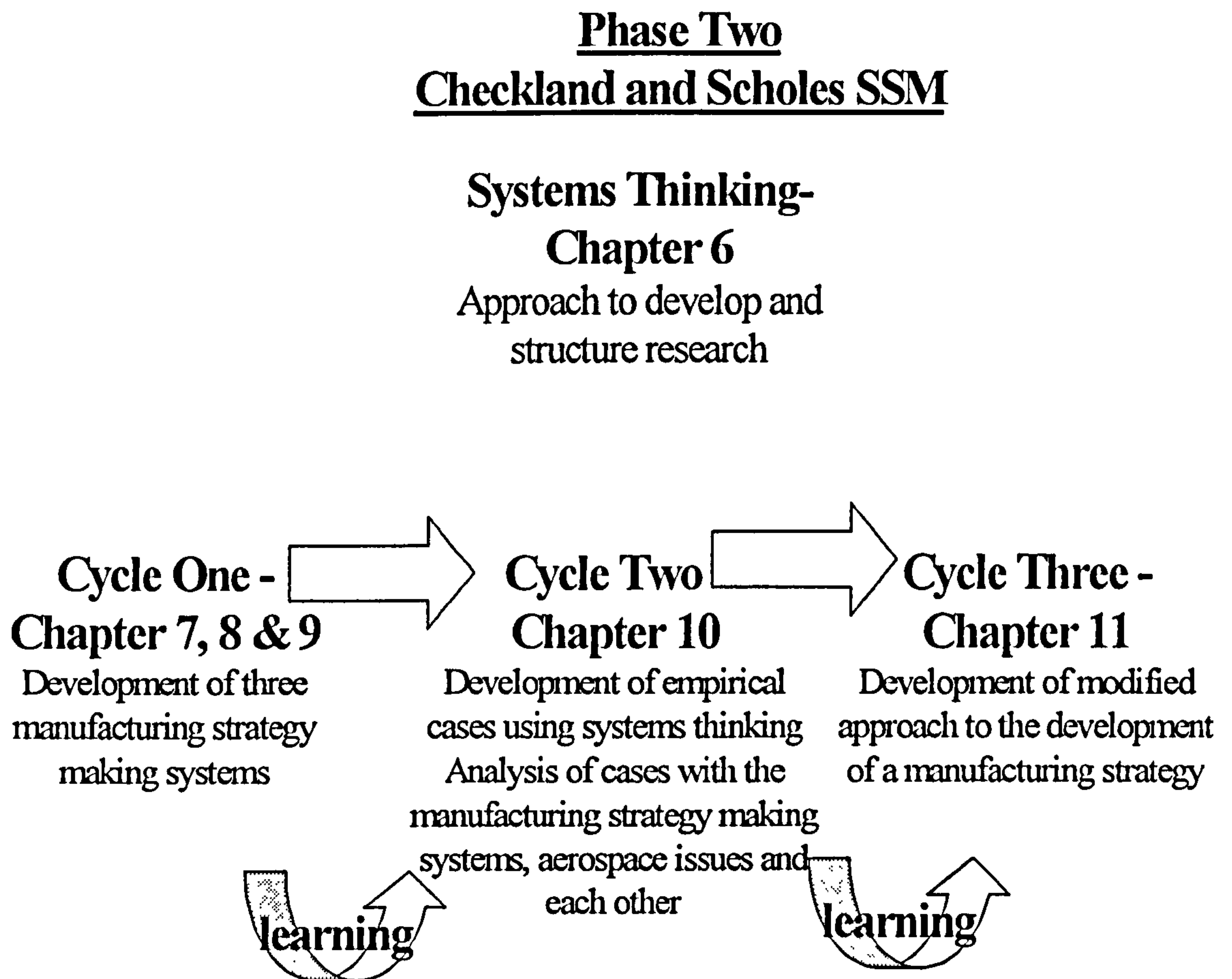

Figure 12 – Phase Two

5.6 Discussion

The chapter has introduced the research methodologies chosen for the research project and identified the criteria that will measure the success of the research output. The main concern of this research and its validity lie in the premise that the research output will be useful to the practitioner.

The following chapters introduce the second phase of the research which is grounded in systems thinking to develop the domain of manufacturing strategy. Chapter

Six introduces the field of systems thinking and discusses why the field is useful in developing manufacturing strategy concepts in the current industrial climate that is embracing the business process paradigm.

6 Chapter Six - Systems theory and the business process

paradigm

This chapter introduces the field of systems theory which was identified as a useful basis on which to develop the remainder of the research.

6.1 Introduction

This chapter has the following objectives:

- To identify the usefulness of using systems thinking in the context of the research when researching and developing a modified approach to the formulation of manufacturing strategy.
- To describe the evolution and nature of systems thinking,
- To define the terms associated with systems thinking which will be used in subsequent chapters
- To describe Hard Systems Thinking (HST) and
- To describe Soft Systems Thinking and to contrast the two approaches.
- To describe the evolution and development of the business process paradigm in the context of this research, including the concepts of business process re-engineering and business processes.

The chapter concludes with a summary of the benefits of using soft systems thinking as a tool for researching and developing a manufacturing strategy.

6.2 Systems thinking

Systems thinking has been identified as the underpinning discipline which will be used to develop the research further. The usefulness of using systems thinking provides the analyst with frames of reference and a common language to enable comparisons and inferences to be made.

Soft systems thinking enables the researcher to develop ideas and concepts using a robust structure which allows creativity and provides insights. This robustness is provided from the systems concepts and parameters that will be used to describe current manufacturing strategy archetypes in systems terms, and helps the researcher to think systemically and explicitly.

6.3 Evolution of systems thinking

Typically, scientific research has been based on the concept of rationalism and reductionism as introduced by Descartes (See Russell, 1946) as the appropriate method of determining solutions to scientific problems. This method can be described as a systematic approach to problem solving. This type of reductive analysis has been described by Wilson (1984) as

‘The most successful explanatory technique used in science’.

This method involves breaking down a problem into its component parts, addressing each part and then building the solution up again.

Systems thinking has been developed as a method which supplements this reductionism but looks at “wholes” or “holons” and their emergent properties as opposed to breaking them down into their component parts and analysing each part in isolation.

The main objective of systems thinking as described by Wilson (1984) is

‘The attainment of public knowledge of the kind which science accumulates by means of a modified scientific approach in which a form of holism replaces reductionism’.

Systems thinking has evolved as a method which aims to make thinking explicit by observing activity and taking into account the world view or 'Weltanschauung' which makes that activity meaningful. Kant (1781) articulated this as:

'observed activity is only meaningful to us in terms of a particular image of the world'.

This was illustrated by the quote *'One man's terrorist is another man's freedom fighter'* (Anon).

6.4 The nature of systems thinking

A 'system' may mean many things to many people, however in the literature it is described in two ways (Checkland, 1981). These are the ontological view and the epistemological view of a system.

The ontological view of a system states that a 'system' exists in the real world. When we talk about manufacturing systems we may include the machine tools, consumables, materials and operators as part of the system. The system is tangible for example can be seen, smelt, touched and heard. An example of this use of systems thinking was the development of a generic order fulfilment process for manufacturing companies by A Weaver (1995).

The epistemological view of a system describes the real world in systems terms. The concept is abstract in nature and may not necessarily be seen, smelt or touched. Systems concepts are used to describe a situation and are used as an aid to understanding. An example of this could be an organisation. This 'system' can be described using systems concepts and develops our understanding of the linkages between people, processes and technology.

In this research the process of strategy formulation is seen as a business process and as such can be described as a system (Weaver 1995) and learning can take place through the application of systems concepts (Argyris and Schon, 1978).

The notion of a system may be used to describe an organisation, taking into consideration the people, processes, technology, performance measures, customers, suppliers and culture etc. This notion helps us to understand the complex phenomenon that is an organisation by using the ideas and concepts of systems theory, which will be covered in this chapter.

A 'System' has been defined as:

'a set of elements connected together which form a whole, thus showing properties which are properties of the whole, rather than properties of the component parts'

Checkland (1981)

Systems thinking incorporates several constructs to aid the analyst in thinking holistically. These include the concepts of hierarchies, emergent properties, communication and control, and thinking with 'holons' (Boardman, 1995).

Hierarchy theory allows a system to be decomposed. Each decomposition has a relationship with the upper and lower decomposition. The complexity of a system can be managed in this way and allows the analyst to develop each part of the system while keeping the integrity of the system by incorporating these hierarchies.

The emergent properties of a system describe the effects of the properties of the whole, these properties are meaningless in terms of the parts of the whole. An example given by Checkland (1997) is one of a hand. You can learn a lot about the hand when it is not attached to the body, but you will not understand what it can do unless it is attached. Aristotle (See Russell, 1946) is well known for the quote *'the whole is greater than the sum of its parts'*. Another example of this is what can be achieved as part of a team.

Individual team members working in isolation would not be able to achieve what is achieved as a group, as described by Maure-Faure (1998).

Systems theory provides the analyst with attributes to help structure the analysis in a way that makes the thinking explicit. The attributes of a system as identified by Churchman (1971) are the 'objectives, environment, resources, components and management' of the system. Every system must have an objective for it to be 'purposeful activity' and for a system to exist it must be part of a wider system, this is described as the systems environment.

A system must be managed to ensure feedback is incorporated into the purposeful activity to ensure the system is sustained. Without this feedback, the system would cease to adapt to its environment and would expire.

Churchman (1971) also identified the following systems parameters: sources, inputs, transformations, process, outputs, receivers and feedback. Conceptual models may be developed using systems parameters and are used as constructs to facilitate further understanding. The sources are the originators of the inputs, for example an input of titanium for an airframe assembly would originate from the supplier.

The inputs are 'things', which are transformed into outputs, the process is the act of changing the inputs in to the outputs, and the receivers are the beneficiaries of the outputs. The transformation within a system is the difference between the input and the output, that is the fact of the change. A feedback mechanism is required to ensure the system is sustained and evolves to cope with the environment. The relationship between the parameters are shown in figure 13.

Systems Parameters

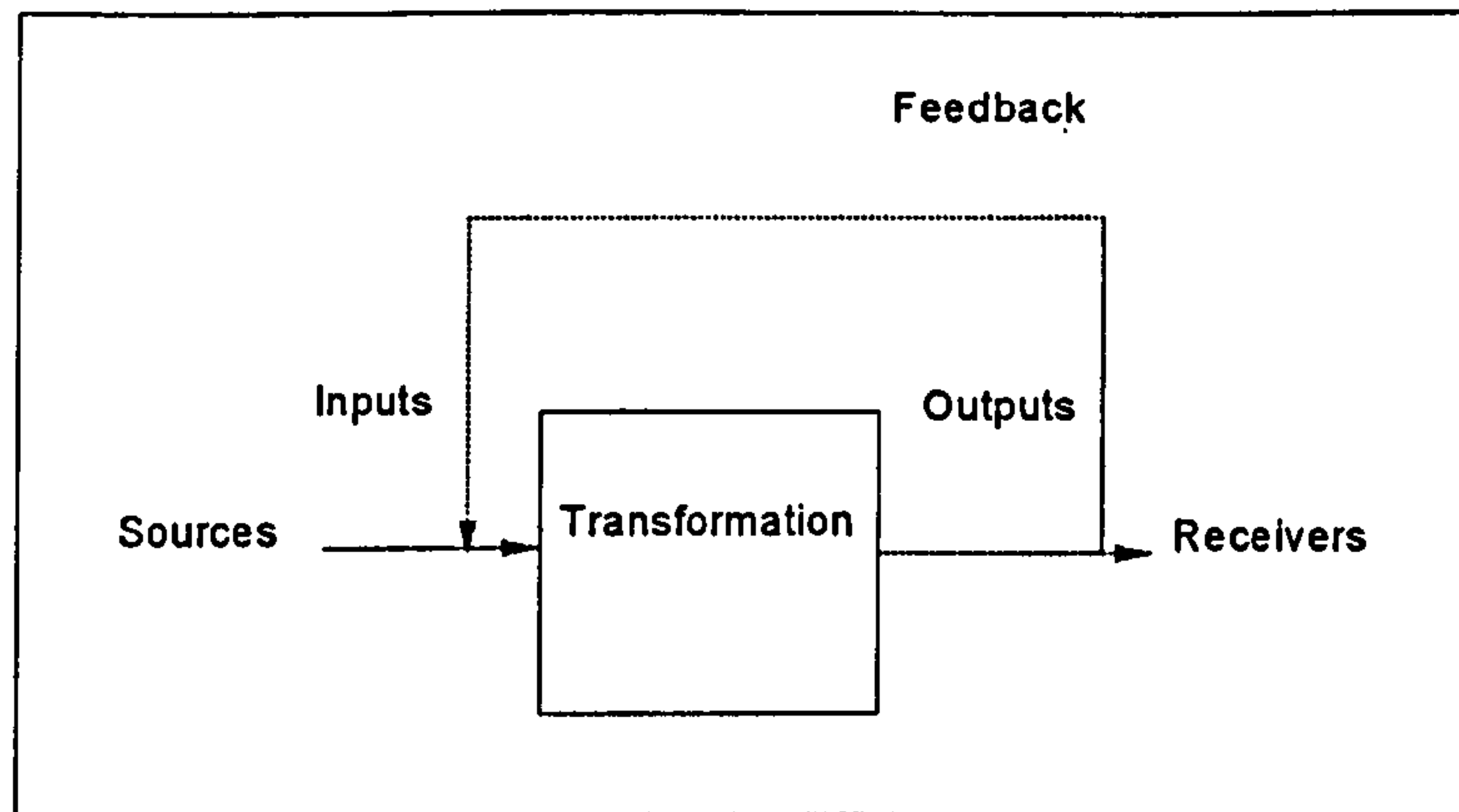

Churchman 1984

Figure 13 – Systems Parameters

Four systems types have been identified by Checkland (1981) to enable the analyst to label the ‘system’ under analysis. These include natural systems, designed physical systems, designed abstract systems and human activity systems:

Natural Systems have not been designed by humans. These include the solar system or a fish. **Designed Physical Systems** are designed by humans for specific purpose such as a flexible manufacturing system. **Designed Abstract Systems** are developed by humans to represent *‘the ordered products of the human mind’* such as a Journal. **Human Activity Systems** are a set of activities carried out by humans in order to fulfil a given purpose such as an order fulfilment process within an organisation (Checkland, 1981).

These classifications aid the analyst in choosing suitable language to meaningfully describe the system and to identify relevant parameters. The evolution of systems theory can be described by splitting the literature into hard systems thinking and soft systems thinking.

6.4.1 Hard Systems Thinking (HST)

HST views the real world as being systemic and uses systematic tools and techniques to analyse the system under consideration. 'Systemic' means taking a holistic view of the system and 'systematic' takes a step by step methodological view. This type of systems thinking can be described as the 'optimisation paradigm' Wilson (1984). The optimisation paradigm assumes that an observer looking at the world will be able to identify systems that can be manipulated to improve efficiency.

HST is usually concerned with a single point of view, that is the problem is clearly defined together with specific objectives to aid the analyst in reaching an acceptable solution. Engineering problems are typically solved using HST, a need is defined and objectives are stated.

When hard systems concepts were applied to human activity systems such as organisations, the methods used were not able to provide suitable solutions to problems which were described as 'ill defined, ill structured and messy' (Checkland, 1990). The identification of this was made by Checkland and Boardman at Lancaster University in the late 1960's and led to the development of the Soft Systems Methodology (SSM).

The view that traditional systematic methods were not sufficient to solve complex, ill defined and messy problems was acquired by Checkland from his experiences as a production engineer involved in developing new technologies in the manufacturing sector. He experienced problems in implementing technological systems that had been robustly designed. He observed that the problems were mainly due to human factors and devised a method to address the 'problem situations' in human activity systems. These issues will be expanded in the next section.

To summarise, HST uses one view of the world and assumes that this will provide the analyst with the optimum solution (Hall 1962, De Marco 1979)

6.4.2 Soft Systems Thinking (SST)

Soft Systems Thinking in contrast to Hard Systems Thinking, views the world as problematic and an ill-defined situation (a problem situation) which can be tackled using certain constructs to aid learning and understanding. This line of enquiry about the 'problem situation' leads to meaningful and feasible changes. SST was developed as a possible solution to the problem of using HST to tackle messy and ill structured problems which are predominant in organisations and is described as a process of enquiry and learning (Checkland, 1990).

The SST approach has been developed by several authors notably Checkland (1981), Wilson (1984) and Ackoff (1981). The key principles that the above authors have in common, consist of the principles of participation and debate, continuity and systemicity.

The principle of participation encourages the analyst to include all stakeholders who have an interest in the system being analysed and an impact upon the implementation of any solution or change identified to that system. An example of how this could benefit the manufacturing strategy process would be the inclusion of key stakeholders of the manufacturing system which would consider the people, process and technology aspects of the human activity system. This would enable all views of what manufacturing should or could achieve to contribute to the competitiveness of the organisation to be exposed and considered in the process of formulating a manufacturing strategy. The principle of debate encourages all the stakeholders to participate in the formulation process to expose possible 'blockers' to the successful implementation of the strategy.

The principle of continuity encourages an approach which is seen as a cyclic process of learning (Argyris, 1992). This involves looking at the process of manufacturing strategy formulation as a system that is evolving and incorporates the human activity system (the organisation).

A benefit of using systems theory in developing an alternative approach is to consider current methods and develop them using explicit language to show the essence of the different approaches. In this research, current manufacturing strategy formulation methods are then compared with empirical data to assess compatibility with the emerging organisational structure using systems theory to identify appropriate changes to be made.

The principle of systemicity encourages the analyst to view the whole picture, to consider the relationships between the relevant systems and to consider how certain modifications will affect the whole system.

The Soft Systems Methodology (SSM) was developed by Checkland et al (1984) to address these principles. SSM can be described as a learning system, which exposes different views of the world, which are then debated with the stakeholders. This process leads to the identification of feasible changes to the system under review. SSM has been developed along two routes of enquiry.

These routes of enquiry are the stream of logic-based enquiry and the cultural based enquiry. The stream of logic based enquiry is described in figure 14. The stream of logic based enquiry is used as a template for the remainder of the research and is therefore described in some detail to set the context for the next five chapters.

Stream of logic based enquiry

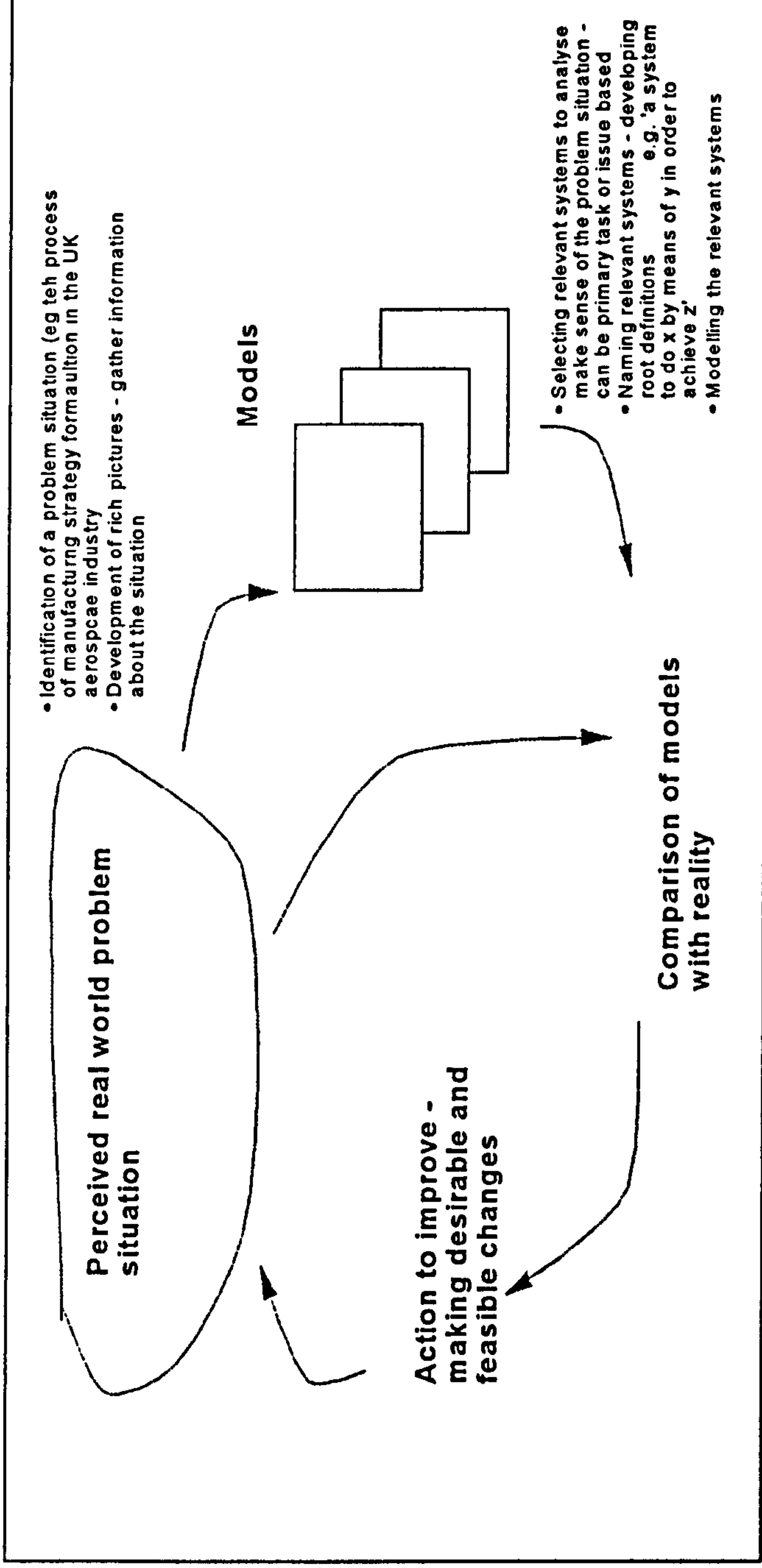

derived from attending a course on Soft Systems Methods with P Checkland 1997

Figure 14 – Stream of logic based enquiry

The stream of logic based enquiry is initiated by the identification that a problem situation exists that can not be solved using hard systems thinking. A rich picture is developed by collecting background information about the problem situation in graphical terms (Lewis, 1992).

The reasoning behind the development of rich pictures is that more information can be conveyed graphically and rich pictures can be more powerful in graphics as opposed to linear prose.

An example of a rich picture is shown below in figure 15. This is the rich picture built up in Chapter Two to show the key issues affecting the competitiveness of the UK aerospace industry.

Rich picture to show the key success factors affecting the competitiveness of the UK aerospace industry

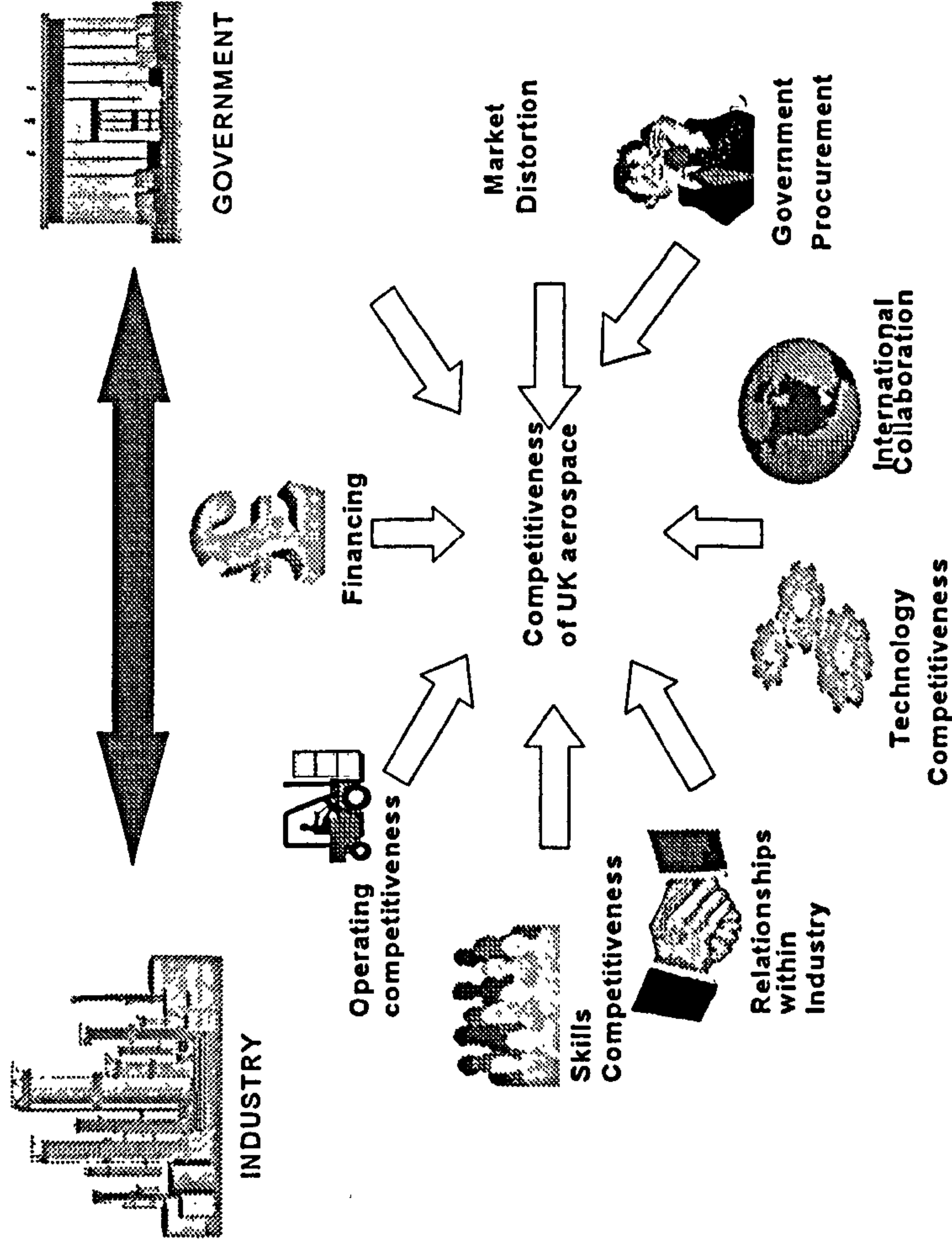

Figure 15 – rich picture of the UK aerospace industry

Following the completion of the rich picture, the analyst identifies 'relevant systems' that are developed in order to make sense of the 'problem situation'. These relevant systems can be 'primary task based' which in our example could be the 'order fulfilment process' of the product which is suffering from a quality deficiency. The relevant systems can also be 'issue based' which could be the 'conflict between the suppliers and producer' for example.

Once the relevant systems have been identified, they are developed by formulating root definitions. A root definition is simply a statement in the form of 'a system to do x by means of y in order to achieve z', and according to the purpose (x) should deal with the elements of the mnemonic CATWOE which identifies the customers, actors, the transformation, worldview and environment of the system.

The customers are defined as the beneficiaries or victims of the process. The actors are defined as the 'things' which carry out the activities within the system, these can be the people or the mechanisms carrying out the activities.

The transformation is the difference between the inputs and the outputs in the system. The worldview or 'Weltanschauung' is the perspective which makes the transformation meaningful in that situation. The environment describes the constraints of the system.

There may be any number of Root Definitions with each having a different worldview for any one system. An example of a conceptual model is shown below in figure 16.

Conceptual model of a system to formulate a manufacturing strategy

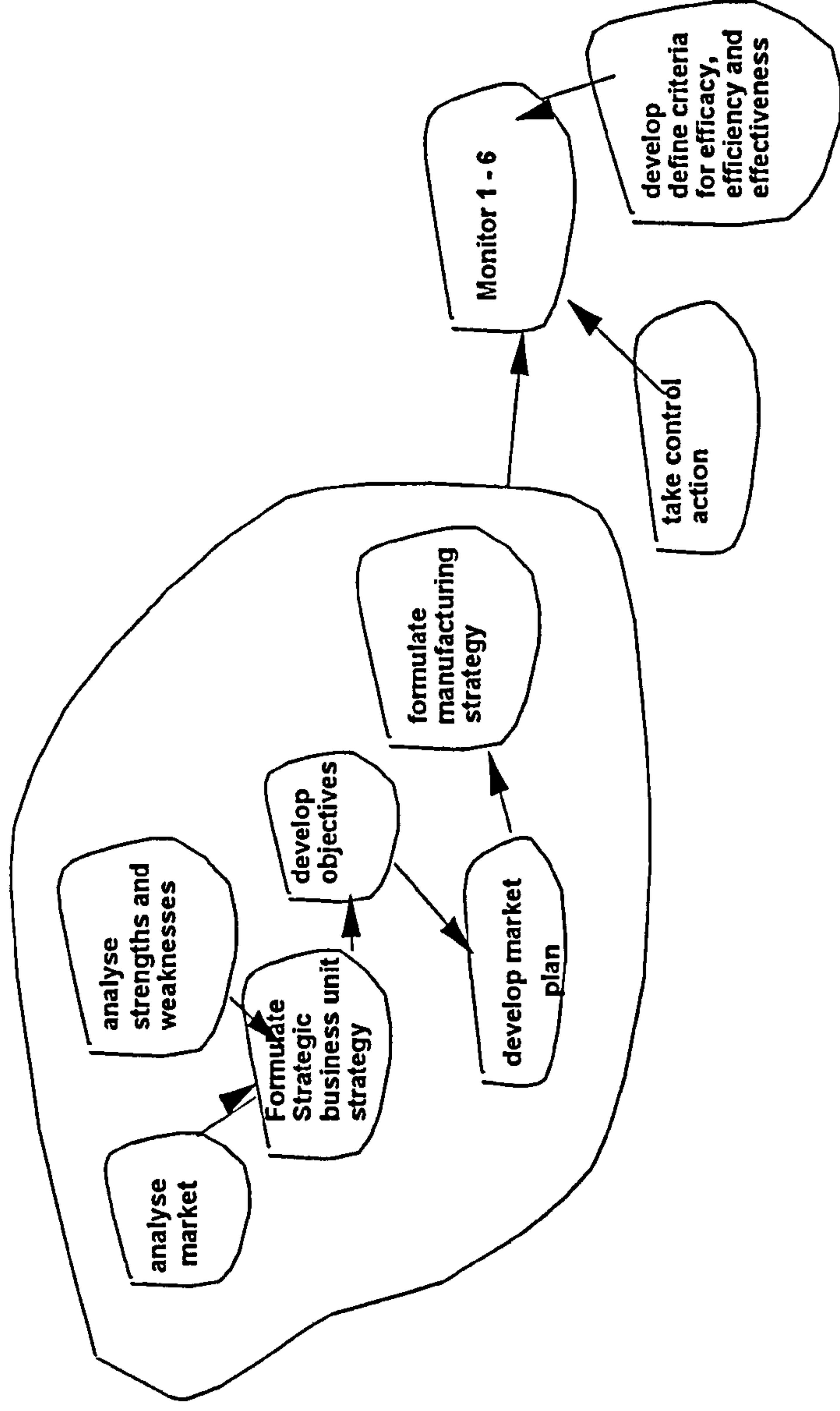
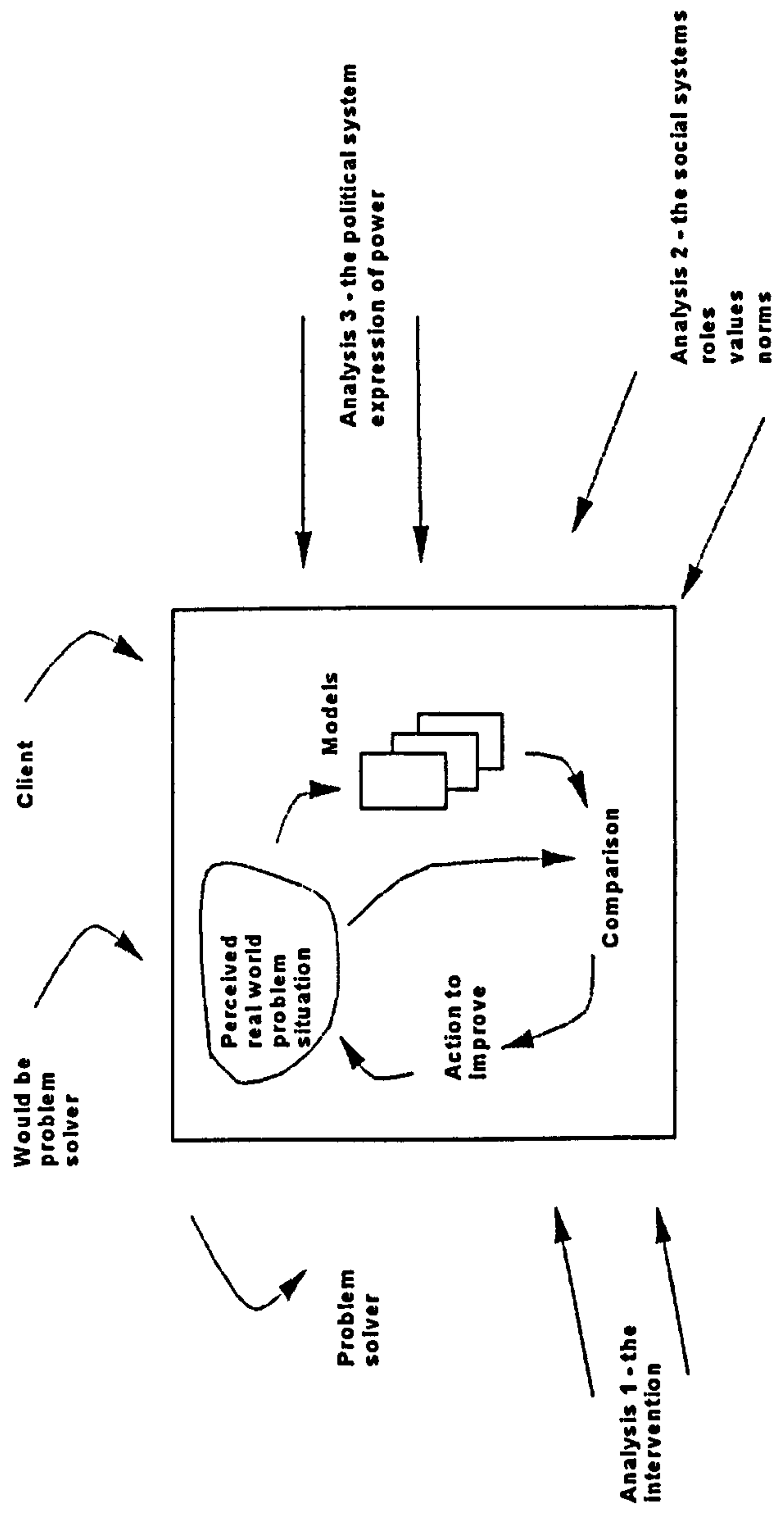

Figure 16 - Conceptual model of a system to formulate a manufacturing strategy adapted from Maruchek et al (1990)

Each choice of a relevant system may incorporate a different worldview and express the problem situation in a particular way. The root definition describes the 'what' of the system from a particular worldview and is used as a starting point to develop a conceptual model to describe the transformations taking place.

When the conceptual model is complete it is compared with the reality as portrayed in the rich pictures. The aim of this comparison is to identify through debate and analysis desirable and feasible changes to the system. The cycle is then repeated until the 'problem situation' is resolved (Checkland and Scholes, 1990).

Stream of cultural analysis



derived from attending a course on Soft Systems Methods with P Checkland 1997

Figure 17 – Stream of Cultural Analysis

The stream of cultural enquiry is initiated at the same time as the stream of logic based analysis to aid in the development of the rich picture and to provide an understanding of the cultural issues at play within the human activity system that is being considered. This is shown in figure 17.

Analysis one identifies the client of the problem situation, this is defined as the person who causes the study to take place (Checkland and Scholes, 1990). The problem owner can be any number of people and can be defined as the stakeholders of the problem situation being considered. The problem solvers are also identified at this stage.

Analysis Two defines the roles, values and norms inherent within the problem situation. The roles are defined as what roles the people take seriously and can be either formal or informal. The norms are the expectations of behaviour people have of a certain role. The values are the judgements that are made about roles and norms.

Analysis Three looks at how power is expressed, for example the political situation of the problem situation. This is a difficult part of SSM as people are generally uncomfortable about discussing issues of this sort.

6.5 Soft systems thinking and manufacturing strategy formulation research

The evidence from the cases in Chapter Four suggests that manufacturing strategy formulation is a 'fuzzy' ill structured process within some organisations whilst most models for manufacturing strategy are rational planned processes. The evidence also indicated that the differences in stakeholders perceptions of manufacturing's role in improving the competitiveness of the organisation would benefit from exposure.

It may be useful to view the development of manufacturing as a competitive weapon, as a problem situation, which can be improved by using alternative

methodologies. Soft systems methods may be useful in developing methodologies which take into consideration all the useful empirical work and experiences gathered in the manufacturing strategy domain and applying them taking into consideration different worldviews.

SST has been identified as a suitable concept to tackle the 'problem situation' of the aerospace industry and its use of manufacturing strategy as a concept to improve the competitiveness of the industry. Platt and Warwick (1995) evaluated the methodology and reiterated the usefulness of SSM for dealing with problems of a fuzzy nature, with unclear objectives, where there may be several different perceptions of the problem. SSM is seen as being flexible and can be used in a variety of circumstances. Omerod (1992) has discussed the merits of combining HST and SST to enable a systematic, systemic approach which incorporates multiple viewpoints.

Chapter Seven, Eight and Nine make use of the concepts described above to develop three manufacturing strategy-making systems which have their conceptual basis in the three archetypes introduced in Chapter Three. Chapter Ten uses the concepts to assess seven empirical case studies of aerospace organisations approaches to manufacturing strategy. The results from Chapters Seven and Eight form the basis for a modified approach to the manufacturing strategy formulation process using systems thinking which is described in Chapter Eleven.

The remainder of this chapter introduces the concept of the business process paradigm which is critical to the thesis and has been developed using systems theory. A business process can be seen as a human activity system (Weaver, 1995) and the business process ideas have become predominant within the aerospace industry recently as the approach used to reorganise organisations to cope with change.

6.6 Business Processes and Business Process re-engineering

The concept of a business process is not new. Parnaby (1979) documented the use of the concept in the Toyota Production System in the 1970s, however the idea of business processes became popularised through Hammer's (1990) paper 'Re-engineering: Don't automate, obliterate'.

One accepted definition of a business process is 'a process which starts and ends with the customer' Childe (1994). Other writers such as Rummler and Brache (1990), Harrington (1992) and Davenport (1993) have provided definitions for a 'business process'. Weaver (1995) developed the following components for a business processes from Checkland (1981):

A business process has a purpose, measures of performance, exists within wider processes and /or the environment with which it interacts, and has physical and abstract resources. Weaver (1995) summarises the business process concept thus:

'can be used to represent a set of integrated activities and flows that as a whole produces outputs that fulfil a purpose with respect to an external customer'.

The mantle was picked up by numerous authors such as Davenport and Short (1990), Hammer and Champy (1993), Kaplan and Murdoch (1991) who identified the usefulness of radical improvement and moving from a functional viewpoint to one of a business process. Subsequently many organisations embarked on ambitious re-engineering programmes to radically change their organisations in order to achieve goals which could not be achieved with small incremental improvements.

The principles of reengineering consist of organising around outcomes not tasks, have those who use the outputs perform the tasks, capture information once and at source and subsume information processing work into the real work that produces the information (Hammer, 1993). Harrington (1992) takes a systematic, incremental approach to BPR and

concentrates on the removal of non value adding processes and recommends process simplification.

The popularity of BPR appears to be waning. Deakins and Makgills (1997) paper 'What killed BPR?' gives some interesting insights into the field and uncovers the position that BPR was not underpinned by much research, and that most papers within the area were based on 'stories' from industry. However it is the view of several authors (Maull et al, 1995), that the most important aspect of Business Process Re-engineering (BPR) is the concept of business processes and the business process focussed organisation. Six issues have been identified by Maull et al (1995) which should be considered when undertaking a business process focussed change programme. These include strategy for BPR, scope of change, performance measures, human factors, process architecture and information technology. Strategy is seen as being crucial to the success of any BPR programme, and so should sit at the heart of the business process debate.

6.6.1 The business process paradigm and systems theory

Several authors including Rummler and Brache (1990), Earl (1994) and McHugh et al (1995) support the concept of a business process being grounded in systems theory. When defining a business process, one useful view is to describe the process using systems ideas and systems thinking as identified by Weaver (1995). A business process can be described as a system and exhibits certain system characteristics including existing in a hierarchy of business processes, exhibiting emergent characteristics, having communication links with other processes.

The development of an organisation as a hierarchy of business processes has been developed by Jorysz H R and Vernadat F B (1990) who divides business processes into manage, operate and support. The 'operate' processes are described as those which 'directly face the customer and add value such as the order fulfilment process'. The

'support' processes are those that exist to enable the operate processes to function such as financial transactions, support of staff, allocation of resources, management of facilities. The 'management' processes are those which set objectives for the organisation, formulate the strategy of the organisation and direct business.

The majority of activity surrounding business processes appears to have concentrated on the operate processes (Maull et al, 1995). However, this research is focusing on the process of manufacturing strategy formulation as a management business process. The research considered the process of manufacturing strategy formulation in business process terms and also considered the evolution of organisations from functional strategies towards business process focussed strategies.

Systems thinking has been used as a concept in the research methodology to learn more about the manufacturing strategy formulation process and to develop the current methodologies to encompass the business process view.

6.7 Discussion

The evolution of the business process paradigm and the move of organisations to a business process focus has shifted the emphasis from functions and hierarchies to becoming closer to the customer, developing core competencies and developing business processes (Greswell et al 1996, Armistead et al 1997). It is imperative that the manufacturing strategy domain evolves with this organisational change to enable the manufacturing operation to support or lead the competitive edge of the organisation.

Systems theory and soft systems thinking has been identified as a powerful mechanism to explore manufacturing strategy and to identify feasible changes to the manufacturing strategy-making system (Berry and Hill, 1992). This is due to the following:

- The principles of participation and debate will be crucial in an organisation which has to deliver manufacturing competitiveness within a business process environment.
- Other stakeholders will be involved in the formulation process and a shared understanding of how manufacturing can shape and deliver a competitive edge is critical.
- The principle of systemicity will become more important as the language used to develop business processes should be migrated to the manufacturing strategy formulation process, and also to show the impacts of strategic decisions taken in manufacturing will have on the other core processes identified.

The benefits of developing root definitions and comparing them to reality in production systems have been discussed by Rhodes (1985). Cleveland (1984) and Weaver (1995) carried out research into improving the management of production systems using systems methods.

The identification of different 'world views' from key stakeholders as to what manufacturing can deliver should reveal potential 'inhibitors' to implementation before they become a major factor. The use of systems thinking will provide a structure for the formulation process, which is linked to the development of the key business processes. The move towards the learning organisation / knowledge management view is emphasising the importance of core competencies. This has implications for the use of systems thinking and systemicity in learning organisations (Kay and Bawden, 1996). Kock et al (1997) have reinforced the view that business processes must be linked to systems thinking. The benefits of this approach will be explored and tested further in the following chapters.

Chapters Seven, Eight and Nine describe the results of the soft systems approach used to define three manufacturing strategy-making systems. These systems are the customer focussed / market led manufacturing strategy-making system, the best practice manufacturing strategy-making system, and the knowledge-based manufacturing strategy-making system. Each system is developed using the process outlined above and is used as

a basis for comparing the empirical data presented in Chapter Ten to identify opportunities for improvement in current manufacturing strategy approaches. These opportunities for improvement are incorporated into a modified approach to the formulation of a manufacturing strategy. This modified approach is presented and validated in Chapter Eleven. Table 3 provides a summary of the soft systems approach taken to define three manufacturing strategy-making systems.

Step	Why
Development of rich picture A rich picture shows the key relationships, issues, content and influences surrounding the archetype	To provide a pictorial representation of the 'problem situation' and to show linkages
Development of root definition To provide a concise statement of the systems under investigation	To ensure focus is not lost, to provide the boundary to the system in question A system to do x by means of y in order to achieve z and CATWOE
Identification of systems parameters To identify the sources, inputs, transformations, outputs, receivers and feedback elements within the system	To enable the development of conceptual models
Identification of systems concepts To identify the objective, worldview, boundaries and management issues, include hierarchy and communication and control	To enable the development of conceptual models
Develop conceptual models To provide process models for manufacturing strategy making	Useful in transferring knowledge from researchers to practitioners

Table 3

6.8 Conclusion

The chapter has provided the theory and concepts which are used in the remainder of the thesis, and has provided the reasoning why systems theory and soft systems thinking in particular is a useful approach in researching manufacturing strategy formulation.

7 Chapter Seven - Development of a market led / customer focussed manufacturing strategy-making system

This chapter continues the systems thinking theme by describing the development and results of using systems thinking and Checkland's Soft Systems Methodology (1990) to develop a market led / customer focussed manufacturing strategy-making system.

7.1 Introduction

The following sections describe the activities and content which were used to develop a customer focussed / market led manufacturing strategy-making system. The current manufacturing strategy literature, described in Chapter Four, was taken a step further and described using the system concepts described in Chapter Six. This is important, as it enables the comparison of three manufacturing strategy archetypes to show the key characteristics of each archetype.

This also enables the comparison of the empirical data that will be described in Chapter Ten, which is developed and described in the same systems language. This in turn enables the identification of feasible and systemically desirable changes to approach a manufacturing strategy-making system. A modified approach is developed and validated in Chapter Eleven, from these results.

7.2 The approach

The approach taken to develop a customer focussed / market led manufacturing strategy-making system made use of systems concepts and Checkland's (1990) soft systems methodology, a full description can be found in Chapter Six. The approach had five steps which were drawn from the above. The approach was also used in Chapters Eight and Nine.

- Step one consists of developing a rich picture to show the key relationships, issues, content and influences within the market led / customer focussed archetype.
- Step Two develops a root definition for the manufacturing strategy-making system to provide a concise statement to enable comparisons with two other archetypes identified.
- Step Three and Four identify the systems parameters and concepts which will describe the manufacturing strategy-making system in more detail.
- Step Five develops the conceptual model from the preceding information provided by the initial steps.

The approach is summarised in table 4.

Step	Why
Development of rich picture A rich picture shows the key relationships, issues, content and influences surrounding the archetype	To provide a pictorial representation of the 'problem situation' and to show linkages
Development of root definition To provide a concise statement of the systems under investigation	To ensure focus is not lost, to provide the boundary to the system in question A system to do x by means of y in order to achieve z and CATWOE
Identification of systems parameters To identify the sources, inputs, transformations, outputs, receivers and feedback elements within the system	To enable the development of conceptual models
Identification of systems concepts To identify the objective, worldview, boundaries and management issues, include hierarchy and communication and control	To enable the development of conceptual models
Develop conceptual models To provide process models for manufacturing strategy making	Useful in transferring knowledge from researchers to practitioners

Table 4

7.3 Systems Parameters and Concepts which are omitted from the definition and development of the three manufacturing strategy-making systems

Due to the nature of defining a manufacturing strategy-making system, several parameters and concepts will be similar for all three archetypes. The following section

explains each parameter / concept which falls into this category and summarises why the parameter / concept is similar regarding manufacturing strategy. The following are not included in the models. However, these elements are included in the modified approach which is delivered in a workbook format.

7.3.1 Customers

Whatever the archetype the customers of a manufacturing strategy-making system are the manufacturing organisation and the people within it. “Customers” was therefore left out of the comparison.

7.3.2 Mechanisms

The means to carry out the activities within the system will vary from company to company (Weaver, 1995). This can be regarded as a matter of detail which can be left out of the comparison. This also allows the archetype to remain general.

7.3.3 Environment

The environment describes the constraints of the system. The constraints will depend on the view the organisation has regarding manufacturing and the manufacturing strategy making process. In order to establish the archetype it can be assumed that the environment in which each archetype operates would be the same.

7.3.4 Owner

The owner of the manufacturing strategy-making system is the person or authority who can cause the system not to exist, which would predominantly be the manufacturing or operations director. This will be true for all manufacturing strategy making systems and can therefore be left out of the comparison of the archetypes.

7.4 Development of a rich picture for a customer focussed / market led manufacturing strategy-making system

A rich picture is developed to describe the 'real world' issues and factors which are important within this archetype and will help to characterise the manufacturing strategy-making system which is developed from the literature described and discussed in Chapter Three.

The key issues and factors which were identified in chapter three for the customer focussed / market led manufacturing strategy archetype include:

- Focusing on customers' needs as the primary driver for the identification of order winners and order qualifiers (Hill, 1993)
- Alignment of key decision areas to enable the manufacturing organisation to satisfy the customer requirements (Hayes and Wheelwright, 1984)
- Outward looking perspective, keeping a sharp eye on the market requirements to ensure the manufacturing organisation is aligned to support those requirements (Whittle et al, 1994)
- Marketing is a key stakeholder within this archetype and problems may occur, if the marketing function has a different view of what manufacturing should deliver compared to the views of manufacturing (Hill, 1985).

Figure 18 shows the essence of the approach.

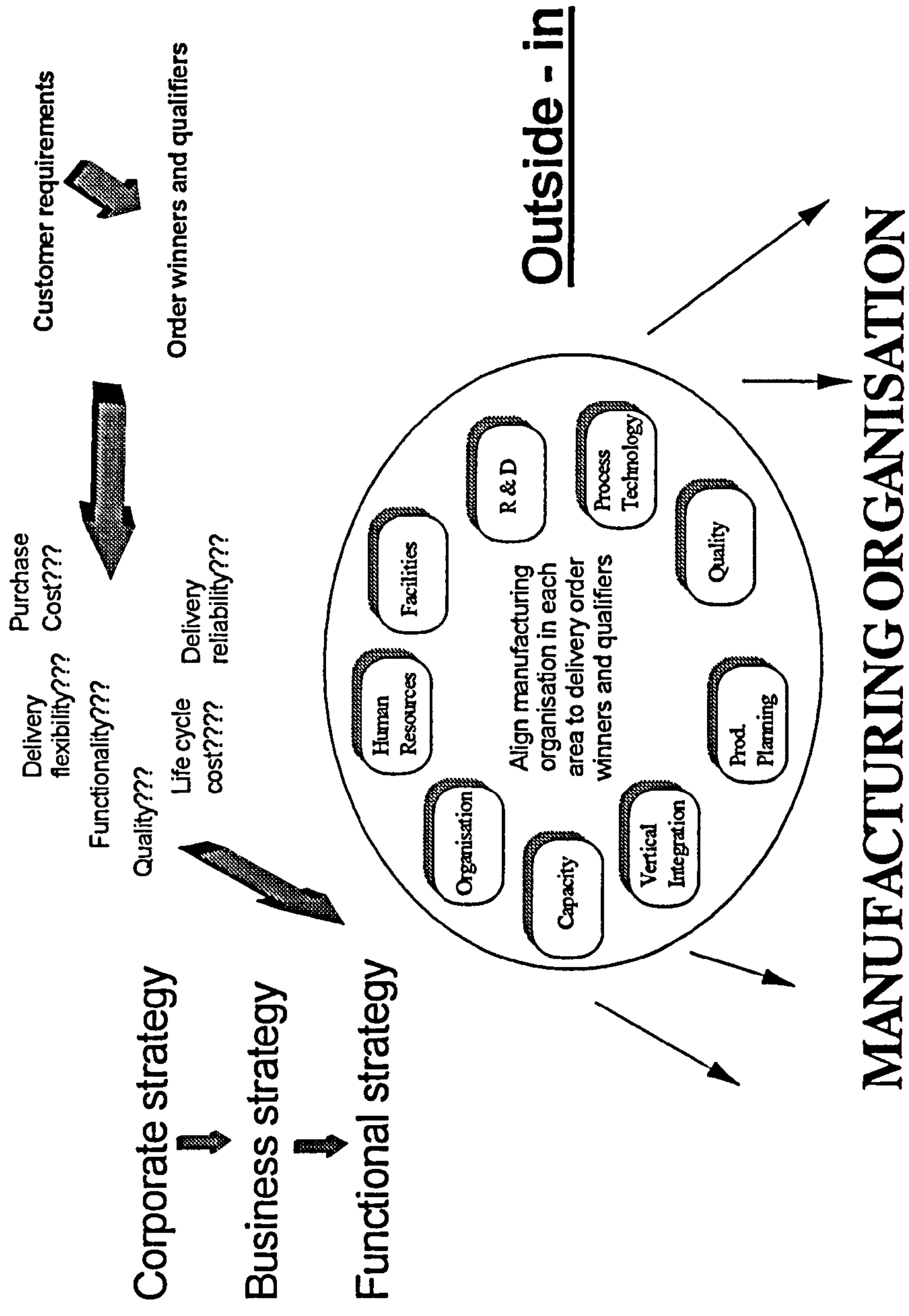

Figure 18 – A rich picture to describe the essence of the customer focused / market led approach to manufacturing strategy

The rich picture shows the influences in the customer focussed / market led approach. These focus on customer requirements, which are fed through the business and ensure the manufacturing systems (processes, people, and technology) are aligned to the customer requirements.

7.5 Development of the root definition

The root definition for a market led / customer focussed manufacturing strategy-making system has been defined as:

'A manufacturing strategy-making system developed to produce a manufacturing strategy, which enables the alignment of the manufacturing organisation to support the business strategy, by means of identifying relevant product groups, identifying order winners and order qualifiers for each product group and aligning the manufacturing organisation, in order to achieve customer satisfaction and through customer satisfaction, competitive advantage.'

Elements of CATWOE (which was described fully in Chapter Six) is used to further expand upon the above statement in terms of the systems actors, transformations, and worldviews.

7.5.1 Actors

The actors are the manufacturing or operations director, senior managers, marketing professionals, and the manufacturing systems designer. These are the people involved in developing the manufacturing strategy. Within the customer focussed / market led archetype, the importance of involving the customer and the marketing organisation is

highlighted as being important. Hill (1985) identified marketing as being a crucial element in the development of a manufacturing strategy.

7.5.2 Transformation

The transformation of the system is the changing of the customers' requirements in the form of order winners and order qualifiers into the manufacturing strategy and action plan to align the manufacturing systems identified with the customer requirements.

7.5.3 Weltanschauung / world view

The worldview of this system is the belief that manufacturing companies must respond to the demand of their customers and markets to be competitive (Hill 1995, Draaijer and Boer 1995, Fry et al 1994, Bozarth 1997). It is a world-view where the company follows the market rather than actively shaping the market.

7.6 Development of the system parameters

The next phase builds on the root definition and adds to the transformation elements. The sources, inputs, process, outputs, receivers, and feedback elements are considered in more detail, to enable the development of the conceptual models.

7.6.1 Sources

The sources of the inputs come from company historical data, customer needs, product information, marketing data, feedback information in the form of performance indicators and especially from a change in the market place. These sources provide the inputs into the manufacturing strategy-making system (Hill 1994, Platts et al 1996).

7.6.2 Inputs

The inputs are principally related to customer requirements and competitor performance. The inputs to the system will include customer requirements, to enable the identification of changes in alignment if necessary. Product family data (Hill 1984, Mills 1995) may be an input, which will include order winning criteria and order qualifying criteria which are defined in Chapter Four. Manufacturing performance data is an input that will be provided to determine if the current strategy is being achieved and identify any changes required. The inputs are fed into the system to enable the transformation to occur to provide a manufacturing strategy aligned to customer requirements.

7.6.3 Process

The activities that occur are taken from the approaches described in Chapter Three.

The activities include:

- Identification of corporate objectives and the identification of marketing objectives
- Identification of manufacturing objectives to support marketing objectives
- Identification of the changes required to the current manufacturing infrastructure and structure and the issuing of the strategy in the form of an action plan (Hill, 1985).

7.6.4 Outputs

The output of the process is a manufacturing strategy - action plan to align the manufacturing organisation with the customer requirements (Hill 1985).

7.6.5 Feedback

The feedback mechanism will include performance measures to identify how the process is performing and to identify improvements in the process and the outcome (Neely et al, 1994)

7.7 The Conceptual model

Inputs	Activities	Outputs	Constraints
Customer requirements Product family data Order winning criteria Order qualifying criteria Manufacturing performance data	Identify 1 corporate objectives 2 marketing objectives 3 manufacturing objectives to support marketing objectives 4 changes to manufacturing infrastructure 5 changes to manufacturing structure Issue strategy	Manufacturing strategy – action plan to align the manufacturing organisation with the customer requirements	Change in customer requirements

Table 5- Summary of parameters/concepts a market led / customer focussed manufacturing strategy-making system.

The conceptual model was developed to show the essence of the system. Only the top levels were developed at this stage, as each organisation using the model will be able to tailor their own requirements. It was considered beneficial to show the models in the IDEFo format. The reasoning behind this was to be able to use the IDEFo models to compare against the empirical data derived models in Chapter Eleven. The model is shown in Figure 19 and has been influenced from Hill (1985).

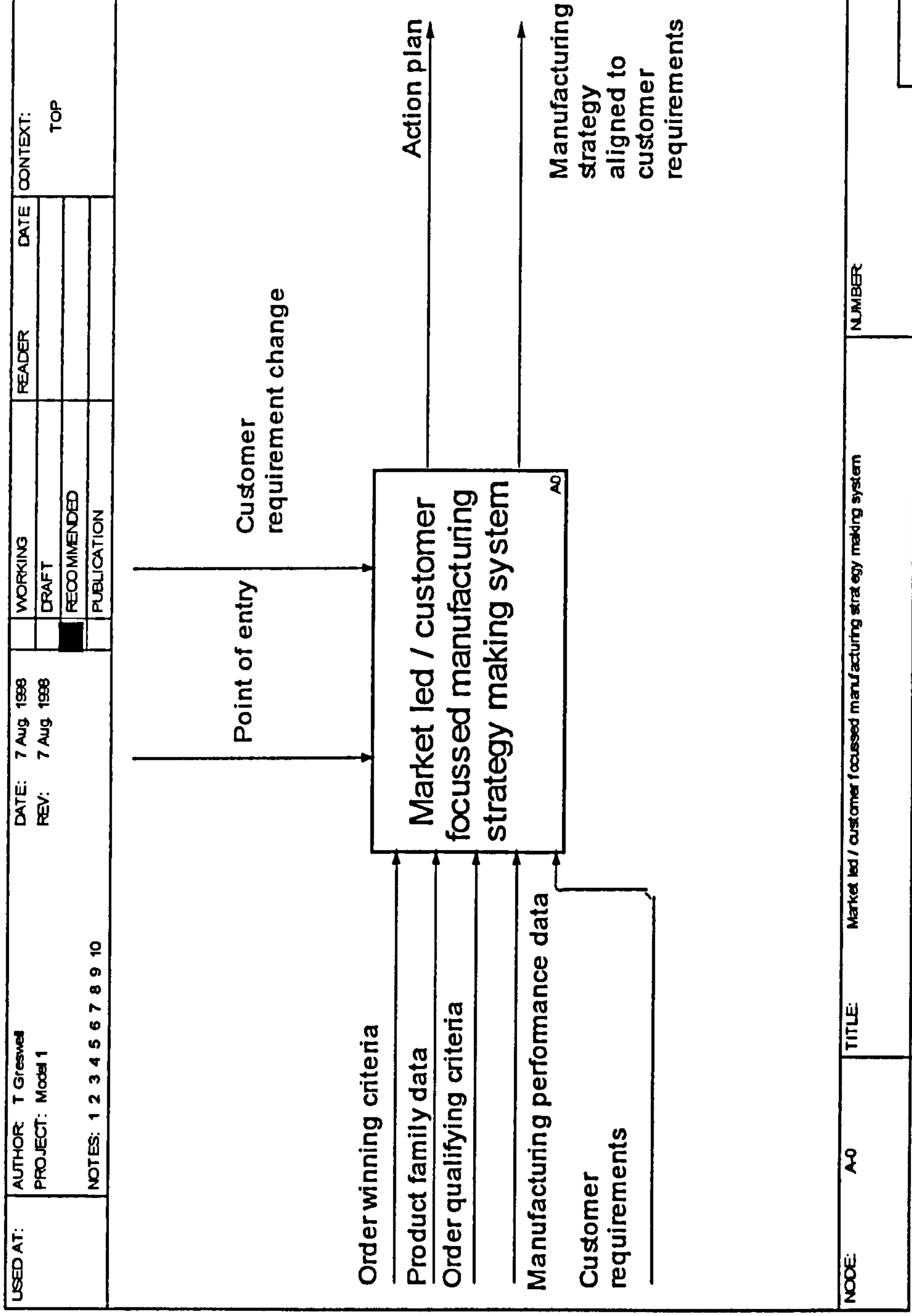

Figure 19 a Conceptual model for the customer focussed /market led manufacturing strategy-making systems

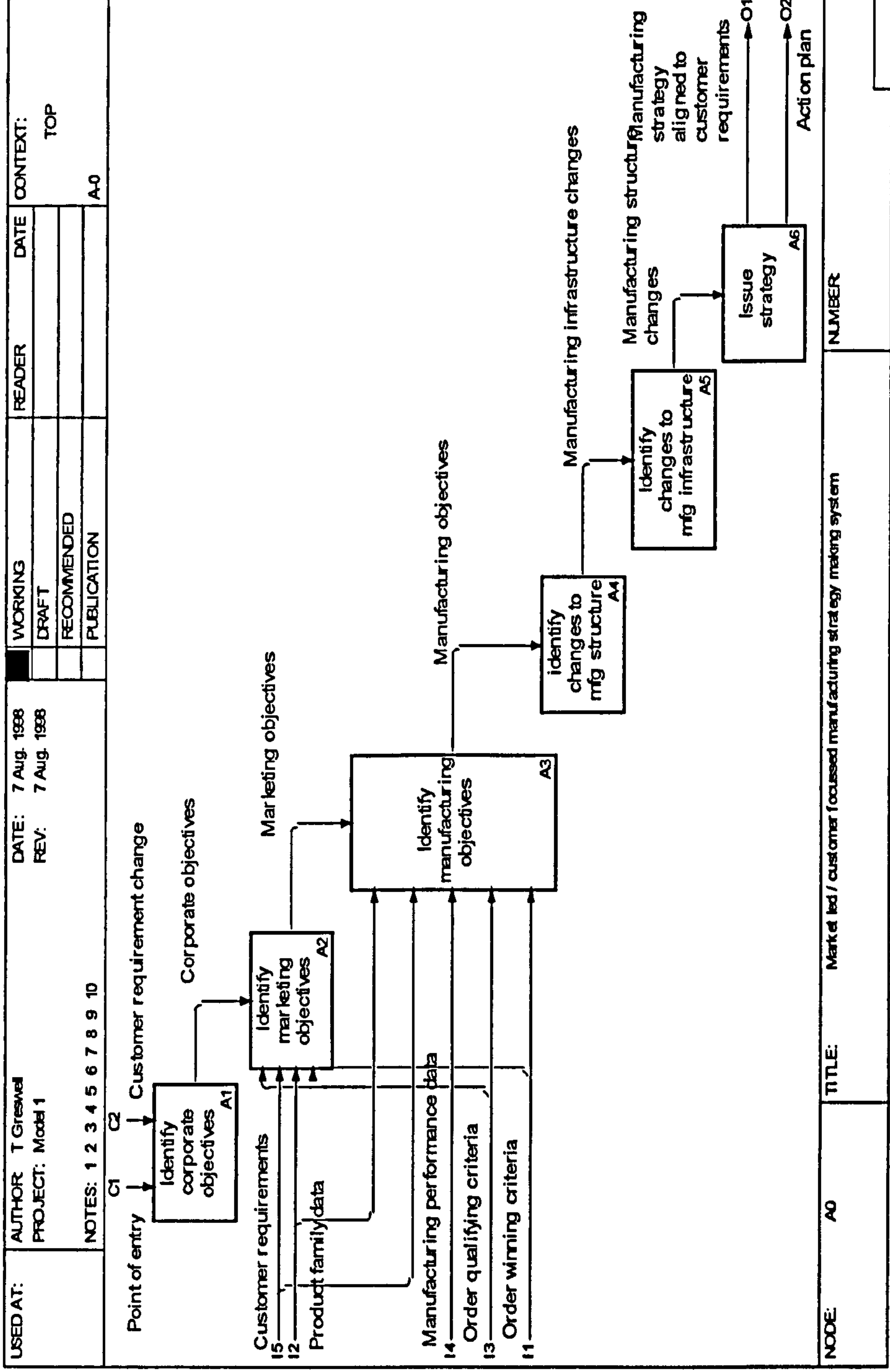

Figure 19 b Conceptual model for the customer focussed /market led manufacturing strategy-making systems

7.8 Summary

The chapter has defined a customer focussed / market led strategy-making system using Chapter Three for the grounding theory. The conceptual models will be compared the experiences of seven aerospace case studies approach to manufacturing strategy making.

8 Chapter Eight - Development of a best practice

manufacturing strategy-making system

This Chapter continues the systems thinking theme by developing a best practice manufacturing strategy-making system using the same principles as Chapter Seven.

8.1 The development of a rich picture for a best practice manufacturing strategy-making system

The key issues and factors which make up the rich picture for the best practice manufacturing strategy-making system were identified as:

- developing people, process and technology excellence in order to deliver operational excellence (Voss 1995).
- focus on the philosophy that becoming the benchmark for the industry will lead to a sustainable competitive advantage.
- a search for best practices which cumulatively lead to superior performance (Camp, 1989).
- Learning from best practice (Schonberger 1986)
- Sources of best practice include: MRP2, OPT, JIT, BPR, TQM, lean production, EFQM (Voss, 1995)

Figure 20 shows the essence of the approach.

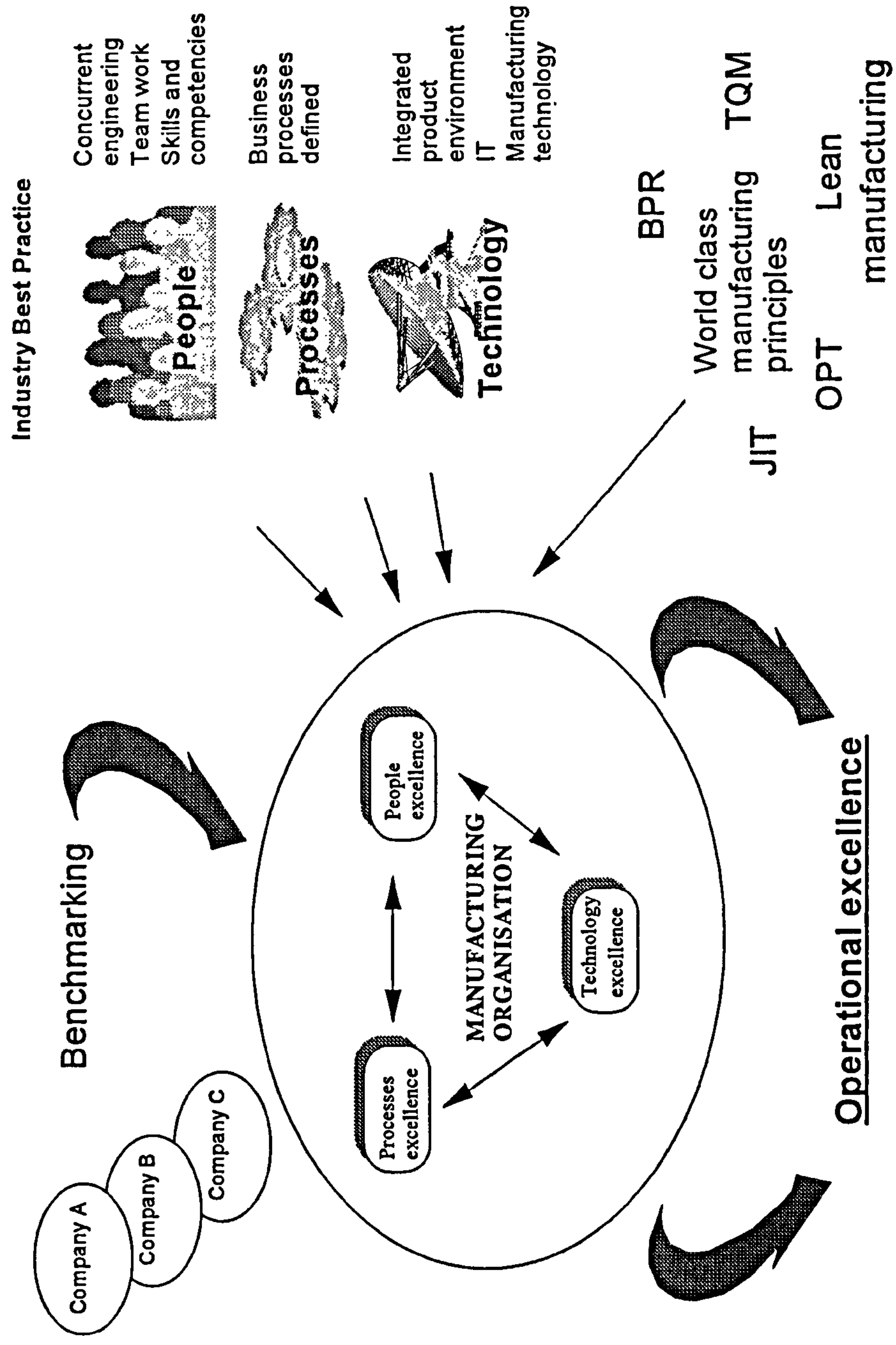

Figure 20 – Essence of best practice approach

8.2 Development of the root definition

The root definition for a best practice manufacturing strategy-making system has been defined as:

'A manufacturing strategy-making system developed to produce a manufacturing strategy which identifies current best practice in the people, process and technology elements of the manufacturing system and by implementing current best practice manufacturing philosophies and techniques, by means of competitive benchmarking and continuous improvement of the people, processes and technology elements within the manufacturing system, in order to improve the competitive position of the organisation by becoming a world class organisation and the industry benchmark.'

CATWOE is used to further categorise the above statement in terms of the systems actors, transformations and worldviews.

8.2.1 Actors

The actors of the best practice manufacturing strategy-making system are the people within the manufacturing organisation. This is because to become a benchmark organisation and to achieve excellence in the people, process and technology elements within the manufacturing system, all will need to be involved (Camp, 1989). The key actors however will be the Manufacturing director, senior managers, and manufacturing engineers. It will be generally these people, who identify the current industry best practice and develop the change programme to achieve it.

8.2.2 Transformation

The transformation of the system is the changing of the inputs which will include current industrial benchmark information and current manufacturing people, process and technology information into the outputs which will include a manufacturing strategy and action plan.

8.2.3 Weltanschauung / world view

The worldview of this system is the belief that manufacturing organisations can become competitive by emulating the best in their industry and striving for excellence in their people, processes and technology (Voss, 1995)

8.3 Development of the system parameters

The next phase of the development of a Best Practice manufacturing strategy-making system builds on the root definition and adds to the CATWOE elements. The sources, inputs, transformations, outputs, and feedback elements are considered in more detail, to enable the development of the conceptual models.

8.3.1 Sources

The sources for the inputs will come from bodies such as the Department of Trade and Industry to identify the current industrial benchmark, and the organisation itself to provide the information required about the current manufacturing systems status (Camp, 1989).

8.3.2 Inputs

The inputs to the system will include current industrial benchmark information to enable the organisation to make a judgement about where they currently are within the

industry as a whole and to provide a starting point to the process. The inputs will also include any current manufacturing systems data, which is collected through a performance measurement system (Camp, 1989).

8.3.3 Process

The activities within the system and the mechanisms which are used to carry out the process to provide a best practice manufacturing strategy. These activities are taken generally from the models described in Chapter Three. The activities include:

- Identification of current industry best practice
- Identification of current manufacturing performance
- Comparison of current performance to best practice
- Identify changes to manufacturing infrastructure
- Identify changes to manufacturing structure
- Issue action plan

Mechanisms which could aid in the carrying out of the activities are

- The performance measurement system
- Manufacturing audit report
- Business excellence model
- Supplier certification programmes

8.3.4 Outputs

The output of the process is a manufacturing strategy to progress the manufacturing organisation towards people, process and technology excellence.

8.3.5 Feedback

The feedback mechanism will include performance measures to identify how the process is performing and to identify improvements in the process and the outcome. The system is controlled from best practice data from the relevant industry, process or technology which will affect the people, processes and technology of the organisation. The effectiveness of the approach depends on performance indicators which are built into the organisation to enable suitable comparisons to be made and acted upon (Bititci et al, 1997).

The top down process can be described as the business setting targets which individual parts of the business are expected to achieve within given timescales. These targets are taken by the manufacturing organisation and turned into action plans. That is the direction of the strategy corresponds to the targets set, and the journey corresponds to the action plans produced. The bottom up approach may use continuous improvement or radical change to achieve the targets using data gathered from the industry to determine who or what is best in class.

8.4 The Conceptual model

Inputs	Activities	Outputs	Constraints
Current industrial benchmark Current manufacturing systems	Identify current industry best practice Identify manufacturing performance compare to industry best practice Identify changes to manufacturing infrastructure Identify changes to manufacturing structure Issue strategy	Manufacturing strategy - action plan to incorporate best practice within the people, processes and technology of an organisation	Change in industry best practice new technology new processes advancement in people management and learning

Table 6 - Summary of parameters / concepts for a best practice manufacturing strategy-making system

The conceptual model was developed to show the essence of the system. Only the top levels were developed at this stage, as each organisation using the model will be able to tailor their own requirements at the lower level. It was considered beneficial to show the models using an IDEFo format. The reasoning behind this was to be able to use the IDEFo models to compare against the empirical data derived models in Chapter Eleven.

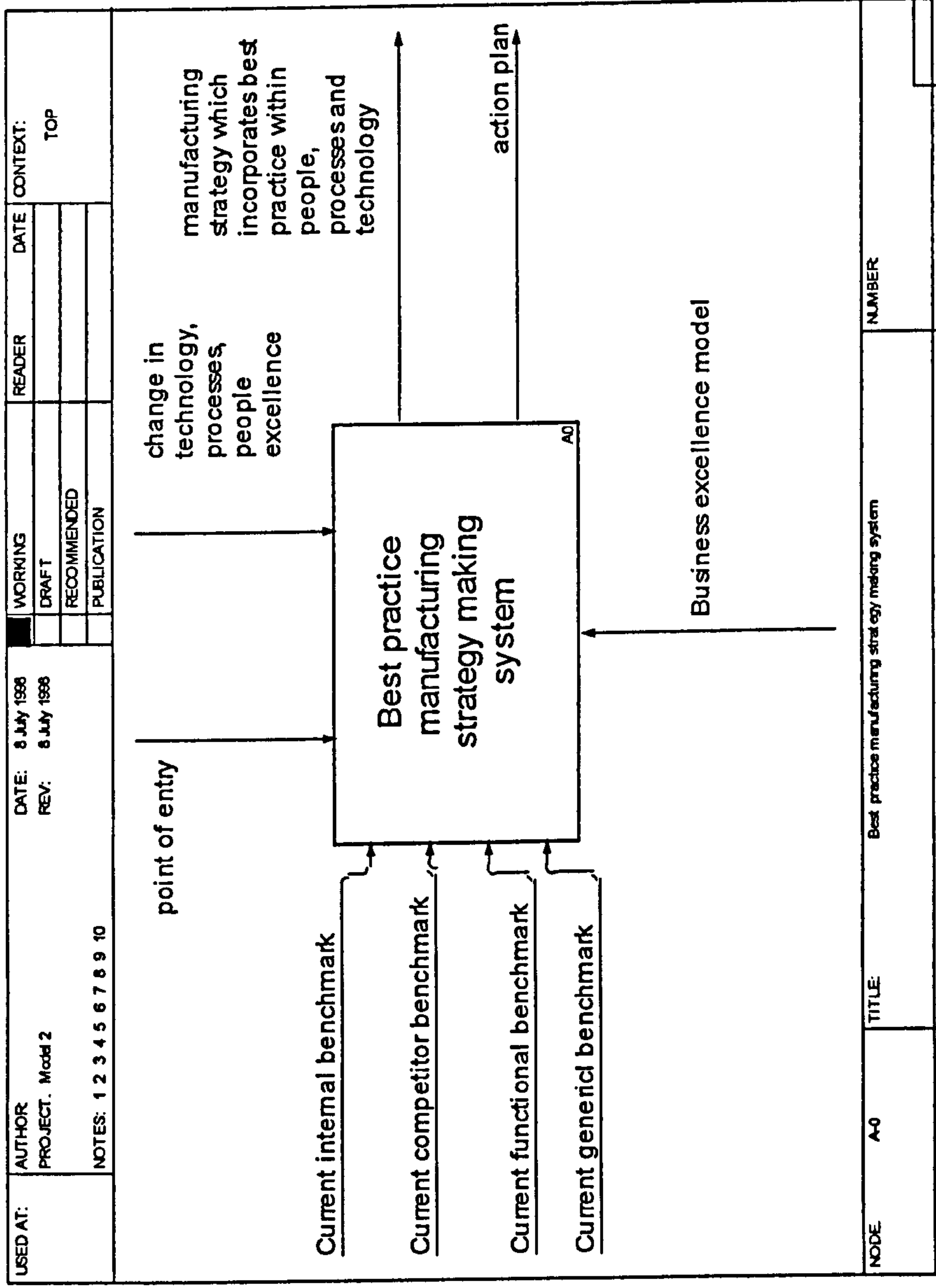

Figure 21a Conceptual model for the best practice manufacturing strategy-making systems

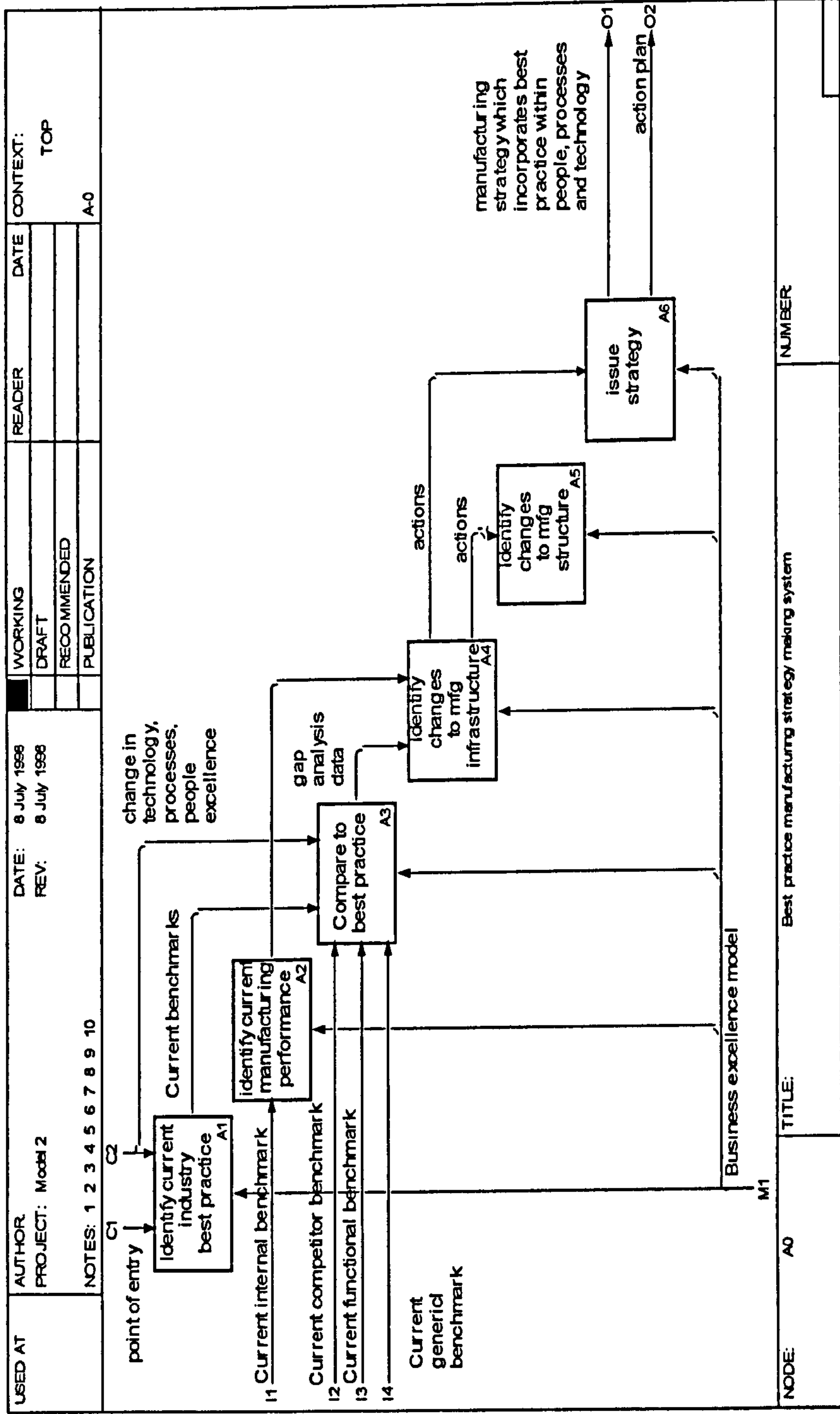

Figure 21b Conceptual model for the best practice manufacturing strategy-making systems

8.5 Summary

The chapter has developed a best practice manufacturing strategy-making system using Chapter Three for the grounding theory. The conceptual models will be used to compare the experiences of seven aerospace case studies approach to manufacturing strategy making which have been submitted to the same process of developing the empirical data into conceptual models. This allows a fair comparison which identifies where changes can be made to current methods which will be incorporated into a modified approach delivered in Chapter Eleven.

9 Chapter Nine - Development of a knowledge-based manufacturing strategy-making system and comparison of the three manufacturing strategy making systems

This chapter continues the systems thinking theme by describing the knowledge-based manufacturing strategy-making system using the same format as Chapter Seven and Eight.

9.1 The development of a rich picture for a knowledge-based manufacturing strategy-making system

The key issues factors which were identified in chapter three for the knowledge-based manufacturing strategy archetype include:

- focus on developing competencies around the aspects of people, process, and technology, especially those which are difficult for other organisations to replicate.
- identifying and developing core competencies which are difficult to replicate to enable new markets to emerge with high barriers to entry for other competitors. This will lead to a sustainable competitive advantage, as no other organisation will be able to match the critical characteristics of the organisation, which are intrinsic within its core competencies (Hamel and Prahalad 1990, Hayes and Pisano 1994, and Teece, Pisano and Shuen 1997)

Figure 22 shows the rich picture associated with the archetype.

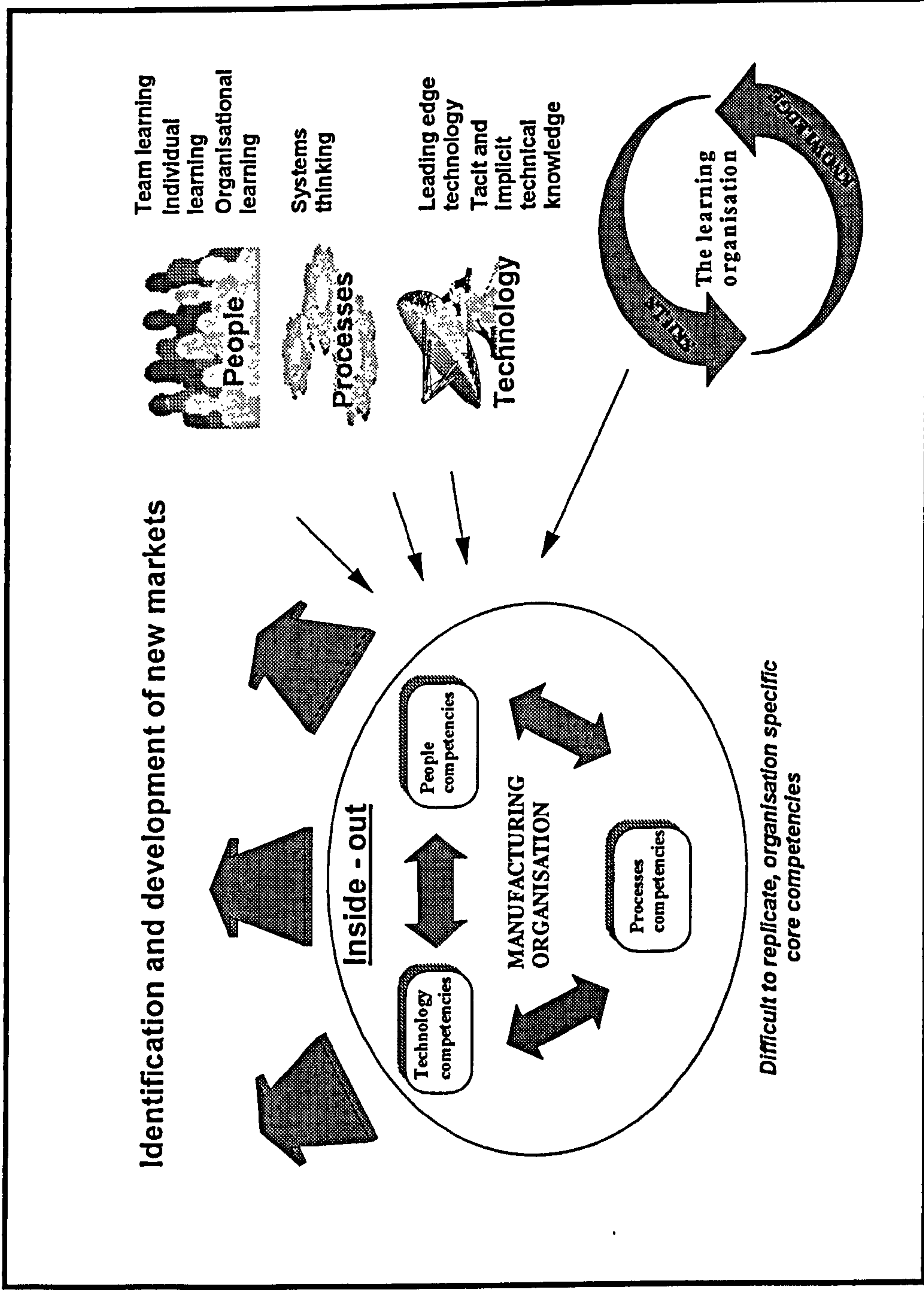

Figure 22 – essence of knowledge based approach

9.2 Development of the root definition

The root definition for a knowledge-based manufacturing strategy-making system has been defined as:

'A manufacturing strategy-making system developed to: produce a manufacturing strategy which identifies, develops, and nurtures technological, process and human core competencies (For example the skills and knowledge which are difficult to replicate) within the manufacturing system), by means of skills and knowledge audits of current skills and knowledge, held within the organisation and a gap analysis which identifies where development is required to meet the objectives of the business, in order to stay ahead of the competition by developing new markets and directions from those core competencies, and from these new markets, competitive advantage.'

The CATWOE elements actors, transformation and worldview is used to further categorise the above statement.

9.2.1 Actors

The main actors of the knowledge-based manufacturing strategy-making system are the manufacturing or operations directors, the manufacturing managers, personnel and training professionals. This is because they are best placed to be able to identify the current core competencies within the organisation and to be able to make the best judgement as to which competencies should be developed and nurtured or disregarded. The actors will also develop and nurture the core competencies identified (Senge, 1994)

9.2.2 Transformation

The transformation of the knowledge-based manufacturing strategy-making system is the identification and development of core competences to enable new markets to emerge which produces a manufacturing strategy with an action plan to articulate how those core competencies can be developed.

9.2.3 Weltanschauung / world view

The worldview of this system is the belief that the knowledge and skills created and held within the organisation are the organisation's greatest strategic assets, for example the ability to produce carbon fibre composites, or to laser weld can be used to open up new market opportunities.

9.3 Development of the system parameters

The next phase of the development of a knowledge-based manufacturing strategy-making system builds on the root definition and adds to the systems concepts. The sources, inputs, transformations, outputs, and feedback elements are considered in more detail, to enable the development of the conceptual models.

9.3.1 Sources

The sources for the inputs will come from the manufacturing disciplines, people who possess the skills and knowledge about the processes and technologies which drive the organisation.

9.3.2 Inputs

The inputs to the system will include information regarding the current core competencies held within the organisation.

9.3.3 Process

The activities that occur are taken from the approaches described in Chapter Three.

The activities include:

- Identification of current core competencies
- Skills and knowledge audit
- Technology audit
- Manufacturing system / process audit
- Identify gap between the competencies required and what they have
- Develop the approach to develop and nurture the core competencies identified

The mechanisms, which aid in the carrying out of the activities are

- Skills audit
- Skills database
- Learning organisation

9.3.4 Outputs

The output of the process is a manufacturing strategy action plan to develop the core competencies within the people, processes and technology of the manufacturing organisation which will develop new markets and sustain existing ones.

9.3.5 Feedback

The feedback mechanism will include benchmarking information about the development of current core competencies and the development of new competencies. Other feedback mechanisms will be fed back to the system as inputs into the process.

The system is controlled by the aspirations of the people within the business and the business needs which form the requirements for development, acquisition and retention

of knowledge which is nurtured to enable the organisation to become product, process or technology leader within their field.

This archetype has a top down and bottom up approach to strategy formulation. The top down process can be described as the setting corporate strategy, and business targets for developing core competencies and capabilities in order to target and develop new markets. The bottom up approach is based around the acquisition of knowledge by the manufacturing personnel which can be process based, technology based or their own aspirations.

9.4 The conceptual model

Inputs	Activities	Outputs	Constraints
<ul style="list-style-type: none"> • Current competencies (process, people and technology) 	<ul style="list-style-type: none"> • identify current core competencies • skills audit • technology audit • manufacturing process audit • identify gap between competencies required and what they have • develop approach to develop and nurture the core competencies identified 	<ul style="list-style-type: none"> • Manufacturing strategy - action plan to identify, develop, and nurture core competencies 	<ul style="list-style-type: none"> • core competence identified as critical to the survival of the organisation

Table 7 - Summary of parameters / concepts for a knowledge-based manufacturing strategy-making system

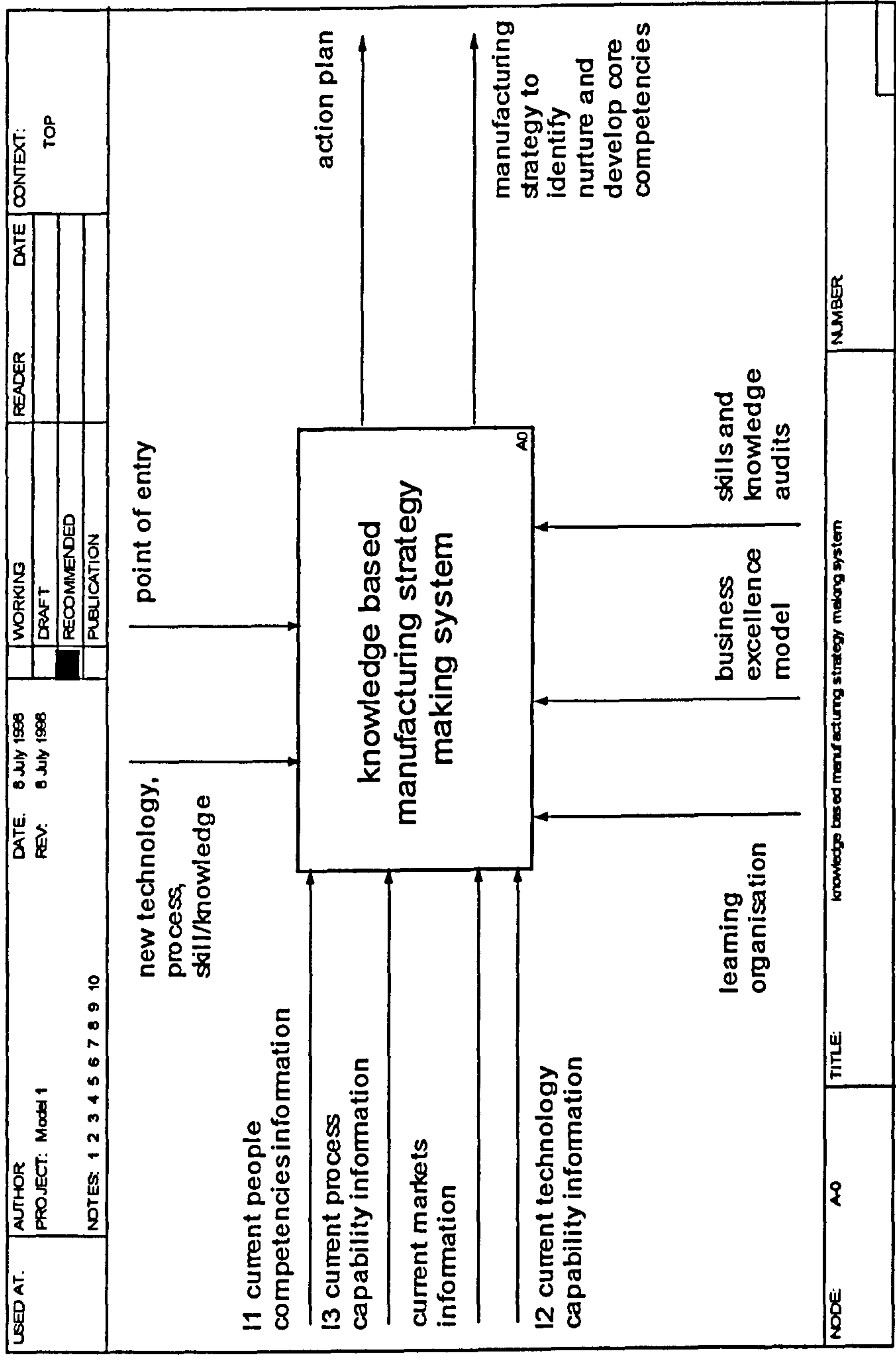

Figure 23a IDEFo conceptual model for a knowledge based approach to manufacturing strategy

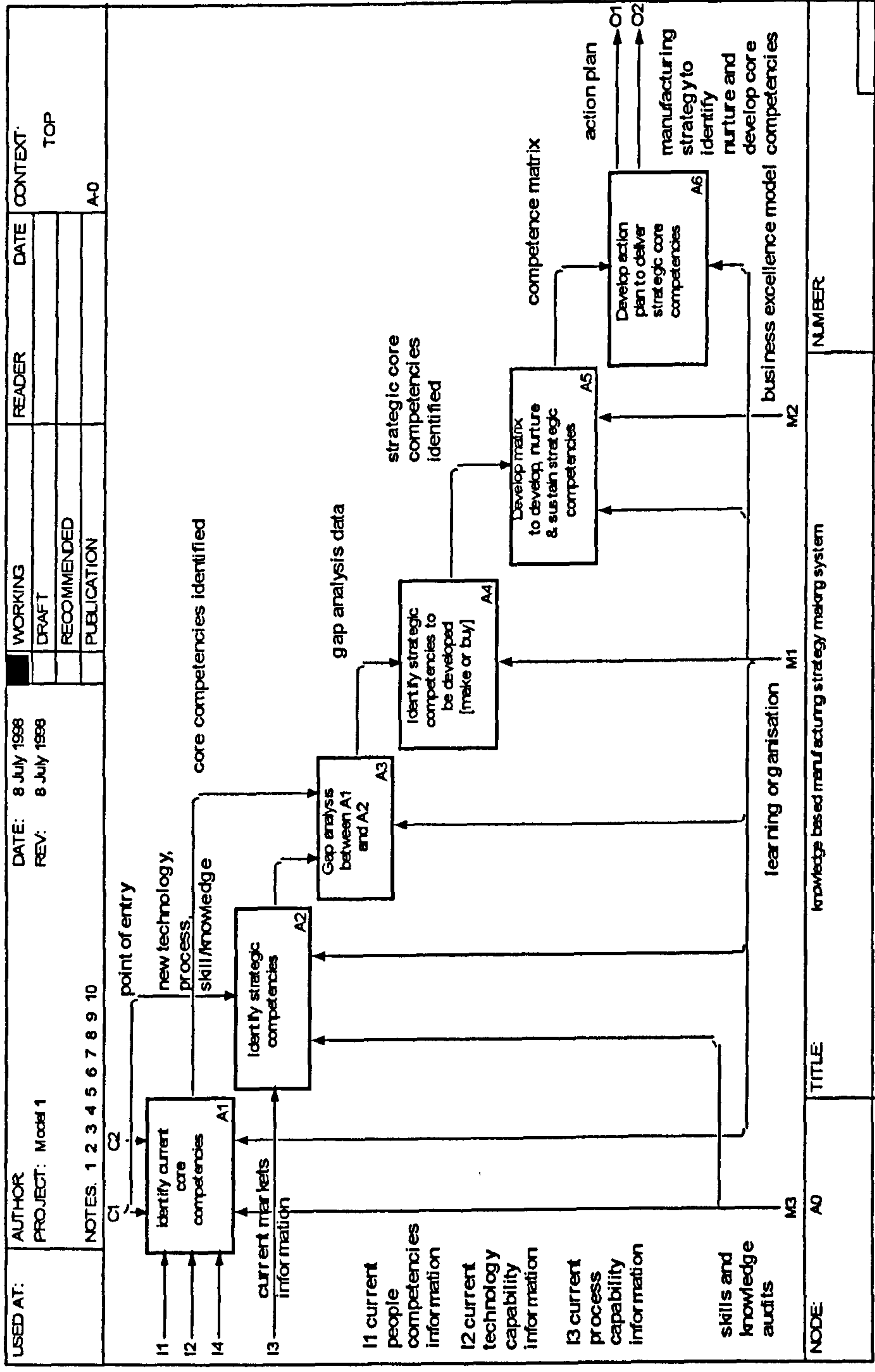

Figure 23b IDEFo conceptual model for a knowledge based approach to manufacturing strategy

The chapter to this point has presented the development of a knowledge-based manufacturing strategy-making system which will be used in the following chapter to compare the empirical data of seven aerospace cases. The remainder of the chapter summaries the three manufacturing strategy-making systems presented in Chapters Seven, Eight and Nine.

9.5 Discussion

The three archetypes described in the preceding three chapters are used in Chapter Ten to compare the experiences of seven case studies carried out within the UK aerospace industry. The cases are compared with the conceptual models to identify the following:

- Whether the current models of manufacturing strategy are appropriate for the challenges described in Chapter Three, and
- Whether a modified approach to manufacturing formulation would be beneficial to individual organisations within the industry.

9.6 Summary of the three manufacturing strategy-making systems

Table 8 shown below identifies the differences in terms of manufacturing strategy components that will be helpful in analysing the empirical data discussed in Chapter Ten. The three manufacturing strategy-making systems defined above should be seen as tools which may aid the practitioner in understanding the emergent strategy that has been formulated previously and to consider other approaches or a hybrid of the approach.

	Market led / customer focussed	Best practice	Knowledge-based
<i>Essence of approach</i>	<ul style="list-style-type: none"> • getting close to the customer to achieve a competitive advantage • order winners and order qualifiers • 'outside in' - market 	<ul style="list-style-type: none"> • application of significantly better operational practices which lead to superior competitive performance • 'outside in' competitors 	<ul style="list-style-type: none"> • development of core manufacturing competencies to gain product / service leadership • 'inside out' market
<i>Infrastructure</i>	<ul style="list-style-type: none"> • customer facing 	<ul style="list-style-type: none"> • competitor facing 	<ul style="list-style-type: none"> • inward facing
<i>Manufacturing philosophies which impact on the archetype</i>	<ul style="list-style-type: none"> • Depending on dominant order winner or order qualifier • Price - low cost operations, lean production, cost optimisation • Quality - statistical process control • Delivery reliability - supply chain management and logistics, lead time compression • Delivery flexibility - flexible scheduling, flexible manufacturing systems - agile production 	<ul style="list-style-type: none"> • Kaisen - continuous improvement • Current best practice manufacturing philosophies considered useful at the time • Integrated product teams • Concurrent engineering 	<ul style="list-style-type: none"> • JIT, Lean production, Integrated product development, Integrated product teams, learning organisation
<i>Inputs</i>	<ul style="list-style-type: none"> • customer requirements • marketing information • business objectives • order winning and qualifying criteria • product family data • manufacturing performance data on the key winning and qualifying criteria 	<ul style="list-style-type: none"> • current industrial benchmark information • current manufacturing systems made up of people, processes and technology 	<ul style="list-style-type: none"> • business needs • current competitive profile • future competitive profile

	Market led / customer focussed	Best practice	Knowledge-based
<i>Outputs - direction of organisation (action plan to move in a direction)</i>	<ul style="list-style-type: none"> design of the manufacturing system to support order winners and order qualifiers to align with customer expectations depending on price, quality, delivery reliability and flexibility 	<ul style="list-style-type: none"> changes to the manufacturing organisation (people, processes and technology) required to move the organisation to becoming the benchmark 	<ul style="list-style-type: none"> current capabilities / competencies and future requirements for manufacturing team and individual learning
<i>outcome of manufacturing strategy-making system</i>	<ul style="list-style-type: none"> a manufacturing strategy which focuses on delivering customer satisfaction through the manufacturing capability in order to achieve competitive advantage 	<ul style="list-style-type: none"> a manufacturing strategy which focuses on the identification and adoption of best practice within people, processes and technology in order to deliver a competitive advantage 	<ul style="list-style-type: none"> a manufacturing strategy which focuses on the core competencies (people) and core capabilities (processes and technology) of the wider manufacturing systems to achieve competitive advantage
<i>Point of entry</i>	<ul style="list-style-type: none"> Change in customer requirements 	<ul style="list-style-type: none"> Change in competitors best practice Identification of new working practices, processes technology, skills and knowledge 	<ul style="list-style-type: none"> Change in competencies required Identification of new working practices, processes technology, skills and knowledge
<i>dominant decision areas</i>	<ul style="list-style-type: none"> order winners / qualifiers and appropriate decision areas affected 	<ul style="list-style-type: none"> People, processes and technology focusing on best practice 	<ul style="list-style-type: none"> focusing on the skills and knowledge, competencies and capabilities inherent in the manufacturing organisations people, processes and technology
<i>current methodologies</i>	<ul style="list-style-type: none"> Hill (1985) systematic manufacturing strategy methodology Platts and Gregory (1989) systematic manufacturing strategy methodology 	<ul style="list-style-type: none"> Benchmarking to identify best practice (Camp, 1989) Schonbergers World Class Manufacturing philosophy Lean production The Toyota Production System 	<ul style="list-style-type: none"> Development of the learning organisation Concurrent engineering Core competence mapping Team building
<i>authors</i>	<ul style="list-style-type: none"> Hill Hayes and Wheelwright Mills, Platts + 	<ul style="list-style-type: none"> Schonberger Camp 	<ul style="list-style-type: none"> Hayes and Pisano Tecce, Shuen and Pisano Whittle et al Senge

	Market led / customer focussed	Best practice	Knowledge-based
<i>worldview</i>	<ul style="list-style-type: none"> • manufacturing companies must satisfy the demand of their customers and markets to be competitive 	<ul style="list-style-type: none"> • manufacturing companies must be on a par with their competitors to be competitive 	<ul style="list-style-type: none"> • the knowledge created and held within an organisation is its greatest strategic asset

Table 8

The following chapter describes phase two of the empirical research. This phase focussed on how aerospace organisations formulate their manufacturing strategies in order to:

- Determine if current manufacturing strategy were used in the aerospace industry
- Compare the experiences of the companies with each other
- Compare the experience of the companies with the three manufacturing strategy-making systems and
- Determine how the methods could be improved to fit in with the emerging business process paradigm.

10 Chapter Ten - Empirical Analysis - Phase Two

The previous three chapters introduced the first cycle of the research cycle as described in Chapter Five 'Research Methodology'. The first cycle used Checkland and Scholes (1990) soft systems methodology and Meredith's (1989) research cycle to define three manufacturing strategy-making systems using current literature and systems concepts. The development of three archetypes identified in Chapter Three as manufacturing strategy-making systems provides the basis for the comparison of the empirical cases.

This chapter continues the cycle of learning by introducing and analysing seven case studies, which have developed over the research period. The cases portray each organisation's approach to the process of manufacturing strategy formulation. Each case is compared with the three manufacturing strategy-making systems to identify systemically desirable and feasible changes to provide a modified approach to formulating a manufacturing strategy. The full cases are included in Appendix Two, and are analysed in the chapter text.

10.1 Introduction

The chapter has the following objectives:

- To collect and analyse empirical data derived from the manufacturing strategy experiences of the UK aerospace industry.
- To describe the experiences of seven aerospace industry cases of manufacturing strategy in systems terms.
- To provide a set of objectives for a modified approach to the formulation of a manufacturing strategy, taking into account the changing environment presented in Chapter Three, and the business process paradigm described in Chapter Six.

10.2 Phase Two

In phase two of the research, forty organisations were approached using the Society of British Aerospace Companies and the West of England Aerospace Forum (WEAF) as contacts. These organisations were approached with a letter and a synopsis of the research programme. Nine companies were visited and seven cases were prepared from the data collected. The other two cases provided useful learning experiences but provided unusable data and due to time constraints further visits were not possible.

Senior managers were asked to participate in open-ended interviews based around the issues presented in the letter. In several of the organisations the studies were carried out over a longer period of time (over the three year research period), which allowed the assimilation of further data. *Company reports and media reports have been used to back up the interviews and other data presented.*

Several of the organisations were involved in longitudinal studies to enable a richer picture to be developed and the remaining organisations were visited once. All interview transcripts were returned to the interviewee for verification and to ensure all aspects of confidentiality. Interviewees were asked to add any important aspects of strategy omitted and to indicate if the transcript was a true description of their processes. This ensured the data used for analysis was a useful source validated by the interviewees.

The next section provides a synopsis of the seven cases to enable the comparison of the three manufacturing strategy-making systems and the key themes that emerged from the empirical data. Each case is described fully in Appendix Two and includes a summary of the interviews, conceptual models developed from the interviews. All cases are from organisations within the UK aerospace industry and include prime contractors, systems suppliers, systems integrators, and component suppliers.

10.3 Summary of the empirical cases for phase two

10.3.1 Case D

The data collection was carried out using interviews with the operations director, company documents and the Internet in May 1996. Case D is part of a group which has a turnover of \$2.7 Billion a year, and can be described as a Systems and Components Supplier within the UK aerospace supply chain and also in international markets. Case D is a world leader in the manufacture of advanced technology propeller systems. The company has 50 years of experience in propeller manufacturing and concentrates its core business on medium to large composite bladed electronically controlled propeller systems. The main functions of the business are to design, develop, manufacture, and support propeller systems.

Major objectives include: Responsive and supportive, on time delivery, engineering excellence, cost effective manufacture, quality, Product support. The stated strategy for case D *'to become the worlds leading supplier of advanced technology propeller systems'*

The organisation is divided into three directorates, which consist of Manufacturing, Marketing and Sales, and Engineering. The directorates are functionally orientated with five hierarchical layers. The hierarchy is arranged as follows: Managing Director, Functional Directors, Managers, Team Leaders' and Operators.

The manufacturing strategy formulation process is addressed on an annual basis. A mid term plan is formulated which pin points the issues that will have to be addressed in the next 3-4 years. The top level strategy is distributed to the managers for input and the emerging strategy is then translated into policies and specific goals. The sales forecast is a major input into the strategy and any desirable or feasible changes are budgeted against the forecast. Decision areas include facilities, Information Technology and Tooling. The Manufacturing Strategy Formulation Process appears to be a planned activity from the information provided.

The business plan is a direct output from the manufacturing strategy formulation process and is used to drive the management of performance indicators which are mainly customer driven i.e. delivery performance, rejects (both internal; and external), warranty claims, customer failures, maintenance hours per man hour. 18 critical success factors have been identified.

In 1991 case D was a large organisation with a 'mass' of products. A decision was taken to split the company in to focused factories, which would each become self contained units. The factory was set up to manufacture composite blades. A decision was taken to sub contract out some of these activities. The company is aiming to instil a Concurrent Engineering Environment and to keep control of manufacturing as a core activity.

Future plans include the introduction of cellular manufacturing within the Hercules product group - this would use joint resources such as the lath and the Poly robot. There are plans to introduce the focused factory concept, however at this stage the duplication of plant would not be justified due to under utilisation. At the moment the idea does not make economic sense. However with the development in the market this may be the way the factory develops.

The Order Winners and Qualifiers within the propellers market were described as the Process, Technology and Customer Support.

10.3.2 Case E

The collection of data has been carried out using a series of interviews, workshops and meetings over a 3 year period from October 1994 to August 1997. The organisation is described as a Systems and Component Supplier and the following personnel were involved in the research: Manufacturing Director, Chief Engineer, Research and Development Manager, Manufacturing team Leaders, Purchasing and Supply Director, Graduate Engineer, Cranfield Researchers - CAMSD Project. The sources of data included

Interviews, Workshops, Company Meetings, Company Video, Company Documents, Longitudinal Study, the Internet.

The data gathered over the three year period has been continually validated and updated through a close working relationship with the organisation. The workbook developed in Chapter Ten has benefited greatly from the input of the organisation. The general background can be found in Case C, as this case is a continuation and longitudinal study of the organisation.

Case E can be described as a Systems and Components Supplier within the UK aerospace supply chain and also in international markets. The point of entry for Case E has been described in case C. However, the organisation has moved on from the original approach and has changed its view to that of using an incremental change program to develop a competitive edge within the manufacturing organisation. The following are involved in defining the programme: Manufacturing Director, Chief Engineer, Manufacturing Team Leaders, and Supervisors. The project is ongoing and does not have an end date. The objectives of the project are to develop an incremental approach to change, and to instil a culture of continuous improvement. The process is emergent in nature. However the work done which was described in Case C has imparted a move towards a no blame culture – however it still appears that it has a way to go. The organisation is aiming to become a World Class Manufacturing organisation.

10.3.3 Case F

Case F has been described as a systems supplier. The data collection was carried out using interviews with the operations director, company documents and the Internet in June - August 1996.

The Operations Director's provided a rich picture of the future of manufacturing which is shown in Figure 24.

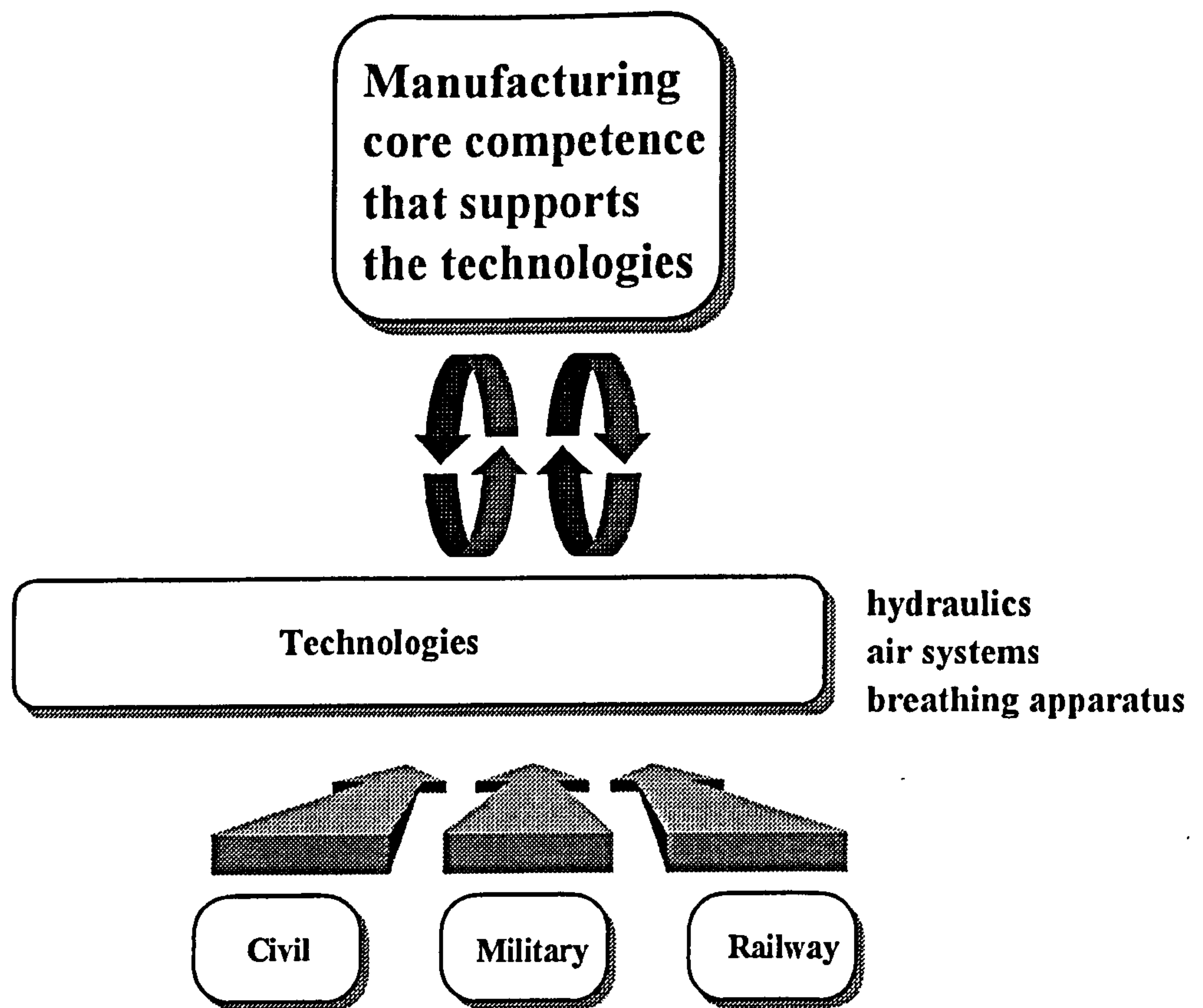

Figure 22

The organisation has experienced a decade of change, which is catalogued in the full case study. The organisation at the time of writing was implementing a cellular manufacturing configuration and implementing world class manufacturing principles.

The corporate strategy is articulated as '*Success through valued service*'. The mission statement is taken by the business units and flowed down as a company strategy in order to satisfy corporate needs. The functional strategies are then formulated with the business strategy in mind.

The manufacturing strategy formulation process appears to be emergent in nature as a result of both external and internal stimuli. No formal process is followed however the performance measures are linked back to the articulated strategy 'success through valued service'. These measures also take into account the order winning and qualifying criteria. A business information system was set up to control these measures. This was to enable good visibility of a series of measures and objectives that were set up within the cells. The

metrics were reduced through out the year and the metrics have become customer focused. The delivery to customer measure is considered most useful.

If the manufacturing strategy formulation process at Case F is seen as emergent, the introduction of cellular manufacturing can be taken as the output of the current cycle of the process. The point of entry for the introduction of cells was provided by external stimuli. The main goal was to improve performance and reduce inventory.

A benchmarking activity was carried out to determine what current levels of performance were like. The measure was the number of hours to do the job. It was decided to reduce the figure by 15%, with a 60% reduction of lead-time and a reduction in inventory. The programme was developed by the Engineering organisation and the Operations Director. No data was provided for timescales.

Overall objectives for Manufacturing:

Long term	delivery on time for OEM schedule adherence	Product cells would lead to a better schedule adherence
Short term	profit to shareholders spares	World Class Manufacturing - reduce costs - increase profits

The culture was described as 'fear used to be terrible', the culture is now described as being a lot more relaxed, with the team working together with no politicking and no wars. The aspect of Continuous Improvement was all tied up within the culture of the organisation. A Total Quality Management programme was initiated in 1988, all employees were sent on a two-day course, however the employees did not buy into the TQM programme thus creating a lack of credibility. A few problems grew within the programme, it was described as 'a bit like the Gestapo'. No measurements or plans were initiated, the Continuous Improvement initiatives were not focused on business needs. The programme appeared to be 'bolted on'.

The Continuous Improvement programme has moved on from the initial problems, the metrics introduced ensured that Continuous Improvement is built into the culture and is seen as routine. Initiatives are driven down from management with more empowerment. It is recognised that the 'hearts and minds' are important and that these will only be won if the values of the company are communicated and accepted. The core delivery processes have been identified as: Engineering, Manufacturing, and Repair. It is envisaged that the processes will be managed via account managers with one account manager for each market sector. The account manager would be responsible for communicating with sales and marketing, engineering and manufacturing, to ensure the customer had one contact within the company to be able to track their orders.

General Comments: 'need to get out of the functional silos'. Operations are the only area where performance is measured. Still firefighting - satisfying the corporation day to day - not addressing the long term issues - maybe the market is too volatile. Team dynamics - still functional. Day to day quality should be part of operations and engineering.

10.3.4 Case G

The data collection was carried out using interviews with the manufacturing director, company documents and the Internet in June 1996. Case G can be described as a Systems and Components Supplier within the UK aerospace supply chain and also in international markets. Case G is a leading manufacturer of advanced electronic equipment and systems for the international defence industry,

Competition within the Aerospace Industry is cut throat with suppliers having to give guaranteed cost reductions of 5 % each year over 5 years. This has led to the formulation of multi disciplinary teams to reduce costs - putting the onus on the supplier for cost savings. The current strategic objectives of Case G are to be the market leader on

Power Management Systems. The organisations' reputation was based on high quality and high cost - now it is fitness for purpose.

The Manufacturing Strategy has a major input into the top level strategy. Targets are flowed down the organisation together with appropriate performance measures. The performance measures are not linked to pay. With the movement towards cellular manufacture and team working, team objectives are set within the cells.

Manufacturing Strategy plan is set for 5 years - it is known at the bid stage if any major investment or change is required. The following process is followed:

Marketing plan - reviewed continually - published annually

Process mapping - to determine what must be done to achieve the objectives derived from the strategy

Forecast of Production - 5 years

Plot sales over 10 years

Plan investments for Engineering and Production

Determine Manufacturing objectives

Performance Measures: It is a requirement to achieve different levels of achievement against certain non-financial performance measures. These measures focus on reducing *lead times, cost* and *stock levels*. The company takes part in a benchmarking club. A great enabler for change is also the preferred supplier schemes run by Prime Contractors within the Aerospace Industry.

Participation in the process includes the Assembly Manager, Manufacturing, Engineering Exec, Material Exec and Manufacturing Director. The manufacturing strategy is also looked at by other members of the board- to see if the strategy agrees with the corporate objectives. The process is triggered by the change in corporate of business strategy and the launch of a new bid. The current objectives are in the long term to

become an *assembly* and *test* organisation only and treble the business in 10 years. In the short term the objectives are to achieve Lead Time reduction, Stock reduction, Cost reduction, Time compression and to become a lean organisation. The order winners and qualifiers were identified as cost, ability to support the product, quality and competence – credibility.

The following decision areas are important in the formulation of Case G's Manufacturing Strategy. Suppliers, Process Choice: Core Competencies: Process or Functionally based organisation: Innovation within Manufacturing: Computer Aided Production Management. The process of Manufacturing Strategy Formulation appears to be a hybrid of emergent and planned.

The cultural issues impacting on Manufacturing Strategy have changed dramatically - used to be a closed book but have adopted an open, frank culture/. Have good communication - good and bad news are communicated straight away. Developed regular communication at all levels - to get rid of rumour control - monthly team briefings. The management now practise an open door approach, run a staff council which helps to resolve problems, appeals procedure and a closed shop manual union together with good communication.

People are becoming multi disciplined, trained on financial awareness and quality aspects of ISO 9000. Team work has broadened job spans and continuous improvement teams are used when failures are discovered to determine the cause.

10.3.5 Case H

The data collection was carried out using interviews, company documents and the Internet in June 1996. Case H can be described as a Components Supplier within the UK aerospace supply chain and also in international markets. The overall strategy was described as: '*Good service, good quality and right price*' with the aim of growing the

business every year. It was affirmed that it is important to know where the business is and which direction it is going in. Investments and capital investments are discussed.

The direction of the company is discussed annually. Key Performance Indicators (KPI) are agreed between the manufacturing director and the general manager. These measures of performance cover: Delivery, Cost of Quality (rework costs), Health and Safety, Zero Working Capital, Sales, Profit

The stretch goals which have been put in place are: 100% delivery performance and 0% defects. The strategies are driven by sales figures and projected workload. Measures of performance are agreed with senior Management and filtered throughout the organisation. A presentation is given to the whole plant, discussions are held with the supervisors to decide how to implement. The following are currently measured: business performance results, cells analysis and plant analysis, cost analysis, profit margin by cell, cost of rework. Costs and delivery performance are not made visible to all employees.

The trigger for the change in operations came from the fluctuations of the market. This was the enabler for the changes that took place within operations. It became clear that the move towards a world class manufacturing ethos together with quality was right for operations. Operations and sales work closely together. The business is analysed once a year to determine if the current strategies are still valid and if any changes need to be made. Projected plans have been drawn up to the year 2000. Current objectives in the long term are World Class Manufacturing and Quality. The short term objectives include: simplicity by set up reduction, multi functional quality improvement teams. The order winners for the sector were reported as Quality, Delivery, Price, Technical Support.

The move towards Cellular Manufacturing is part of the strategic move towards World Class Manufacturing. The cells have been developed to allow total flexibility between cells plants and building. All cells have identical equipment with a multi skilled team. Specialists are also on hand for the supporting role.

10.3.6 Case I

The collection of data was carried out from a six month placement at the organisation. Data was gathered from workshops, meetings, interviews and company documents between October 1997 – April 1998. The organisation is described as a Prime Contractor and Systems Supplier. The colleagues who participated in the study included: Manufacturing development personnel, Manufacturing engineering managers, Manufacturing engineers, Training partners and the Head of manufacturing processes.

The organisation has embarked on a programme called 'Project Axis' which has changed the organisational structure to one which has a project focus, a process focus and a discipline focus. The programme is seen as an enabler for OEI which is mentioned in Case B. OEI aims to deliver superior performance by reducing lead times by 20%, costs by 30% and to provide adherence to schedules by 100%. The company has had to change due to the following factors: Cost plus legacy, An organisation which was neither functional or project, with fuzzy boundaries, responsibilities and accountabilities not matched, and duplication.

The vision which forced the change was verbalised as: *'Effective customer responsive organisation, integrated multifunctional teams with common goals, clear roles, responsibilities and accountabilities, strong internal customer / supplier based relationships, clear project focus supported by functional excellence, freedom to act.'*

The business has been split into three areas, internal supply, customer programmes and others. Internal supply incorporates manufacturing, technical and supply support, customer programmes are the customer facing elements of the value chain and the 'others' include the functions which look after the discipline interests such as manufacturing engineering, enterprise planning and strategic management.

The relationship between the projects and the functions is crucial to the success of the reorganisation. The function is responsible for creating, improving and maintaining

process excellence, providing functional people for the projects, maintaining discipline excellence and benchmarking their people and processes against best in class. The projects role is to interface with the customer, manage the team, identify resource demand, operate defined processes, has financial accountability and is measured against quality, cost and delivery.

The manufacturing strategy formulation process is an outcome from the following: The overall Case I strategy which identifies which business the organisation is in, the core values, delivers the operational value plan and identifies the business excellence model as a framework to develop the business towards world class. This feeds into the technical research and development strategy which delivers the research and development operating principles, identifies the current technology capabilities, places the current technology capabilities within a benchmarking framework, identifies the strategic value of each technology capability and carries out risk and maturity analysis.

The manufacturing strategy process identifies site tiers according to core competencies, by developing a profile analysis, and carrying out competence and strategic sourcing analysis, this delivers a skill capability by function and by cell.

The point of entry for the organisation was the realisation that due to major changes in the market, the operating effectiveness and efficiency of the organisation needed radical improvement. The objective of the effective manufacturing engineering process was ‘a process to ensure manufacturing engineering has the relevant process and technology capabilities and people competencies to support the business in all parts of the project life cycle’.

The decision areas were set by the business excellence model and included people, technology, processes, organisational development, customer satisfaction and performance measures. Each decision area was named as an enabler and a matrix was developed to take each area involved with manufacturing engineering from learner to world class. The process appears to be planned and emergent in nature that is some of the outcomes are

planned but the outcome always has some emergent properties. The process is included in the full case study.

10.3.7 Case J

The collection of data was carried out using a series of interviews and company documents from one visit in June 1996. The organisation is a prime contractor. The interviewee was the Director Product Operations.

The manufacturing strategy tends to be emergent in nature as a result of several stimuli. No formal method for the development of a manufacturing strategy has been identified. The stimuli included best practice, Japanese manufacturing methods, lean manufacturing, cell manufacturing, principles of team working, the parent company benchmark initiative, changes to the corporate infrastructure, Partnerships and a process focus.

A planning framework is in place and is reviewed and changed (if required) annually, this is being replaced by the value plan that is a corporate wide initiative. 'The value plan' is a report which outlines information about the company, the current market environment and the corporate values such as customers, people, partnerships, performance and innovation to the employees. A formal meeting is held to launch the strategy plan, which is then discussed with the important aspects identified. People are then invited to develop the plan and to build on current strengths. The underlying processes are fluid and dynamic.

The development of the manufacturing strategy can be closely related to the management style of the organisation. The management style is working towards 'buy in' and consensus within the organisation and has a profound affect on pushing accountability down through the organisation. Communication was described as being very important - talking and listening.

Early 1991 was described as the point of entry breakthrough. Coopers and Lybrand were brought in as an outside intervention. Feb 1991 - Appointment of a new engineering and manufacturing director. Use of a consultancy firm as the external intervention. The organisation is heavily weighted towards product groups as opposed to functions and the decision to structure the organisation into these derivative product groups has worked well. The following roles are involved in strategy formulation: Product Executive, Manufacturing Director, Business Development Director. The current objectives are to improve cash forecasts by £1 billion by 1998 (this is compared with an order book of £19.5 billion for the entire group of which Case J is a part) - profit forecasts are described as acceptable. The aim is to make the performance of the organisation look acceptable and improve the share price.

The decision areas which make up the content of the manufacturing strategy consist of the balancing of people processes and structure in a way that will improve share holder value. The organisation is a Process Focused Organisation with focussed accountability and teamworking. Natural groups were formed which are broken up and created continuously. This was a crucial component in the breakdown of functions into process teams as was the general education programme.

A pilot study for Product Development was commissioned. A virtual team was put together as a pilot study for the product development process. The team recognised who was working on the product and who their customers were. Project leader appointed - lots of energy achieved a great deal. Sponsor group - achieved remarkable results. Drawing re-issues and overall costs were dramatically improved. 50% under estimated costs. A business Development Director has been appointed to oversee funding and partnerships.

10.4 Cycle Two of the Soft System Methodology

The second cycle of Checkland and Scholes (1990) soft systems methodology is used to develop the data provided by the seven empirical cases into a format which enables the comparison between the three manufacturing strategy-making systems, the rich pictures developed in Chapter Two and each other. The objective is to provide options for changes to current manufacturing strategy formulation processes which are useful to the aerospace POM practitioner, and to promote a systemic approach to manufacturing strategy which is consistent with the business process paradigm and provides a manufacturing strategy process which incorporates cycles of learning.

The approach taken for Cycle Two of the research is summarised below.

SSM	Description	Cycle Two: Empirical Cases
Stage 1	Finding out about the problem situation, gathering background information, developing rich pictures.	The problem situation is a concerned with: how current manufacturing strategy tools and techniques are used to enable UK aerospace organisations to become competitive.
Stage 2	Expressing the problem situation, selecting and naming relevant systems	Identifying how aerospace organisations formulate their Manufacturing Strategy from the data provided from seven case companies. Identifying the emergent or planned manufacturing strategy formulation process
Stage 3	Formulating root definitions (RD)	Formulate the RD for each case to describe the 'a system to do x in terms of y in order to achieve z' and to represent the point of view (Worldview) of each case
Stage 4	Conceptual models	Building the conceptual models from the RD and systems concepts provided from the data
Stage 5	Comparison of models and perceived real world. - Analysis	Comparison of the themes between the cases, comparison of the cases with the rich picture of the industry (i.e. issues) and the comparison of the cases with the three manufacturing strategy-making systems
Stage 6	Defining changes	Identification of systemically desirable and feasible changes to current processes derived from the analysis in stage 5. Identification of requirements for a manufacturing strategy making process
Stage 7	Taking action	Development of a modified approach to the formulation of a manufacturing strategy – Chapter Eleven

Table 9

The learning from this cycle will be used to develop a modified manufacturing strategy formulation process that is described in Chapter Eleven 'the development of a modified approach to the formulation of a manufacturing strategy'.

10.4.1 Stage one - the problem situation:

This section is aimed at discussing and formulating responses to the following questions:

- Are current manufacturing strategy tools and techniques used to enable UK aerospace organisations to become more competitive?
- Are these tools sufficient and adequate for the task?

The objective of stage one was to develop an understanding of the phenomena under review. This was achieved by gathering background information from several sources about the current status of the UK Aerospace Industry, including current issues, competition, key customers and procurement policies of major customers, the structure of the industry including current problems, globalisation, and the evolution of the manufacturing operation within the industry.

This information has been described in Chapter Two and has been developed as a rich picture to show the links and issues surrounding the problem situation, which is defined thus: 'how do we develop the manufacturing operation within an aerospace organisation to help the organisation become or remain competitive'. The rich pictures portray current ideas, frames and models to develop understanding of the issues affecting the competitiveness of the UK aerospace industry and have been described in full in Chapter Two.

10.4.2 Stage Two - identification of systems relevant to the problem

situation

The systems chosen are the planned or emergent manufacturing strategy-making systems in each case study from Phase Two. When considering the case organisations we are considering the manufacturing strategy formulation process and using soft systems concepts to gain a deeper understanding of the process. This is to enable a comparison to be made between current methods and current use.

Conceptual models of the systems are developed in each case. The models are compared with the rich pictures developed in Chapter Two and the three manufacturing strategy making archetypes developed in the previous three chapters. This allows the identification of feasible modifications to current manufacturing strategy-making systems, which enables the development of an alternative approach that is suitable for the characteristics of the aerospace industry.

The seven cases described in 10.3 are summarised in Table 10.

	Position in value chain	Research Method	Relevant System identified
D	Systems supplier	▪ Interviews, company documents, individual study	▪ Planned manufacturing strategy formulation process.
E	Systems and component supplier	▪ Interviews, workshops, company documents, longitudinal study	▪ Emergent manufacturing strategy formulation and process improvement process
F	System supplier	▪ Interviews, company documents, individual study	▪ Emergent manufacturing strategy using cellular manufacturing
G	Systems and component supplier	▪ Interviews, company documents, individual study	▪ Planned manufacturing strategy formulation process
H	component supplier	▪ Interviews, company documents, individual study	▪ Emergent manufacturing strategy formulation process
I	Prime contractor	▪ Interviews, workshops, company documents, longitudinal study	▪ Hybrid of emergent and planned manufacturing strategy formulation process
J	Prime contractor	▪ Interviews, company documents, individual study	▪ Emergent manufacturing strategy formulation process

Table 10

The remainder of the chapter describes the analysis of and findings from the cases. These findings are used to identify and develop feasible changes to current methods that are applicable to the UK aerospace industry.

10.4.3 Stage Three and Four - development of root definitions and conceptual models for each case

To make sense of the problem situation as defined in stage one, each case may have more than one relevant system that may in turn have more than one root definition. The full cases are included in Appendix 2.

Table of root definitions

<i>Case</i>	<i>A system to</i>	<i>By means of</i>	<i>In order to</i>
D	Produce a manufacturing strategy by developing the business plan and change management programme	performance indicators, sales forecast data and other manufacturing information	feed into the organisation's mid term plans
E1	Develop the manufacturing organisation	using best practice manufacturing and change techniques	support the corporate value plan and to 'empty the order book at or below target cost'
E2	Manage and implement change within the organisation as a whole (including the manufacturing organisation)	using the 'journey'	support the corporate value plan and business plan
F	Implement cellular manufacturing	identifying current manufacturing processes, what to make or buy and operations goals	improve the performance of operations
G	Produce a manufacturing strategy	analysing manufacturing and business data	support changes in corporate strategy
H	Develop a manufacturing strategy	analysing the current business, identifying key performance indicators and determining stretch goals	meet the manufacturing operating plan
I	ensure manufacturing engineering has the relevant process and technology capabilities and people competencies	the effective manufacturing engineering process	provide people and process excellence to the project both internal supply and the customer programmes
J	Develop a manufacturing strategy	analysing the business plan and best practice data	drive change management activities

Table 11

The root definitions show the activities of each approach, the means to carrying out the activities and the objective of the manufacturing strategy process.

10.4.4 Stage Five – analysis of cases

The analysis of the cases consisted of three streams. The cases were compared with each other in order to determine if any pattern emerged due to specific characteristics of the aerospace industry. The cases were compared with the issues of the industry developed in Chapter Two to determine if the tools and techniques used within the industry were addressing the issues identified. The cases were also compared with three manufacturing strategy-making systems to determine whether the case approaches were successful and whether the manufacturing strategy-making systems were being used to their full potential.

10.4.4.1 Comparison of the themes between the empirical cases (case with case analysis)

It was considered important to compare the experiences of the organisations with each other to enable any patterns to be identified and to aid in the development of a modified approach using the experiences and needs of the practitioner. The themes included: point of entry, the process - emergent or planned, the manufacturing strategy-making system, current change programmes, project management, participation, and main concerns and key issues concerning manufacturing strategy within the organisation.

The point of entry theme provided evidence that all of the cases perceived manufacturing strategy as important and necessary for the competitive position of the organisation. This was provided from the changes in the market for Cases D, E, H, I, and J. External intervention was the point of entry for Case G with a benchmarking club and Case F from external interventions. The trigger for the majority of cases was the ending of the cold war and the change of contracts from cost plus to fixed price.

The manufacturing strategy making process for the seven cases were split between emergent and planned. Case D had a robust planned manufacturing strategy making process which was incorporated into the business planning cycle. Cases I and G indicated that they had a hybrid of a planned and emergent manufacturing strategy making process. Cases E, F, H and J had no formal process and described their manufacturing strategy making processes as emergent.

The manufacturing strategy-making systems defined in Chapters Seven to Nine were used to classify the cases. Cases D, G and H identified order winning and order qualifying criteria which included cost, support, quality and credibility for Case G, quality, delivery, price and technical support for Case H, and process, technology and customer support for Case D. Cases G and D used sales forecasts and marketing data to influence the manufacturing strategy making process and are therefore associated with the customer focussed / market led manufacturing strategy-making system.

All these cases were involved in some aspect of the best practice manufacturing strategy-making system. Case D was implementing quality management and cellular manufacturing, Case E was using an incremental continuous improvement approach, Case F was implementing cellular manufacturing, Case G was moving towards implementing a computer aided production management system and moving towards a process culture. Case H was taking a process view using cellular manufacturing as an enabler, Case I was using the EFQM approach and Case J was implementing lean manufacturing, cells, benchmarking and a business process focus. Only Case I was involved in identifying core competencies as an alternative approach, which is applicable to the knowledge-based manufacturing strategy-making system.

The participation in Case H included the sales and marketing teams however in the rest of the cases the participation was limited to stakeholders within manufacturing.

10.4.4.2 Inferences from findings from case to case analysis

All organisations recognised the importance of using manufacturing strategy principles to enable manufacturing to contribute to the competitiveness of the organisation. However in most of the cases (E, F, H and J) strategy was emergent as opposed to a process which was used year in year out. Only one case (D) had a process that was used to develop the manufacturing strategy cyclically. The inference from this finding is that the practitioners recognise the need for a manufacturing strategy process but have not yet incorporated such a process into a cyclic programme to enable learning, feedback and development.

Several cases used marketing information to align their processes. Few cases used the knowledge-based approach to developing a manufacturing strategy except for the cases which analysed their people, process and technology competencies to determine change programmes.

It can be inferred from these cases although limited in number, that no standard manufacturing strategy approach is taken within the aerospace industry. The manufacturing strategy formulation processes are mostly emergent in nature, and do not take into account all the issues that affect the manufacturing organisation as a whole. These issues include ensuring the different disciplines involved in an order fulfilment process understand their role and the role of manufacturing in developing and sustaining the competitiveness of the organisation. This suggests that a systemic view could be appropriate because the traditional boundaries of functions are becoming blurred, teams are becoming multi disciplined and a holistic view would provide a clearer picture of the organisation.

The overriding archetype for the aerospace industry from the (limited) cases is the best practice archetype, with three organisations following the market led approach to a certain extent (Cases D G and H). However the benefits which can be derived from the

market led and knowledge-based approaches do not appear to be considered. A systemic approach which is flexible enough to incorporate all three archetypes yet structured enough to provide an organisation with a route map and guidelines to formulate a manufacturing strategy could be useful.

10.4.4.3 Comparison of cases with the rich picture

The empirical data indicates that some of the major issues identified, such as the merger of the European industry and the move towards a business process focus, are not being addressed by the approaches that the organisations are using at present. The rich pictures present a view of a rapidly changing environment and any approaches which will be developed for use by aerospace organisations needs to be robust enough and structured enough to cope with these changes.

It is important to emphasise the aspects of key stakeholders within the manufacturing processes, people and technology as this will have an even greater impact when the industry becomes more integrated. The problems experienced by some organisations within their own boundaries such as the differing views of manufacturing and marketing as in Case E, will be compounded if the modified approach does not expose differing views. Only Cases H G and D ensured key stakeholders from outside the manufacturing organisation were involved in the process. With a move towards a business process focus and the blurring of functions into order fulfilment processes, the identification and integration of key stakeholders into the manufacturing strategy formulation process may be critical.

10.4.4.4 Inferences from findings of cases to rich picture analysis

The inference that can be made suggests that the supply chain within the industry will become more integrated so a common and shared purpose will become crucial. This is substantiated by Case I and J who are moving towards integrating their value chain and integrating the organisation and also including their suppliers. The exposure of different worldviews within the value chain will need to be recognised and debated to ensure the manufacturing strategy of the supply chain is pulling in the same direction.

10.4.4.5 Comparison of cases with three manufacturing strategy-making systems

10.4.4.5.1 Market led / customer manufacturing strategy-making system

Three cases used elements of the market led / customer focussed approach. Cases D, G and H identified key order winners and order qualifiers and used them to build up their performance measurement systems. Cases H, G and D included the marketing stakeholder in the process, which is a key element of the approach.

10.4.4.5.2 Best practice manufacturing strategy-making system

The data has led to the conclusion that the best practice approach is the favoured one within the aerospace industry. All cases were involved in some aspect of the best practice manufacturing strategy-making system. Case D and F were implementing quality management and cellular manufacturing. Case E was using an incremental continuous improvement approach. Case G was moving towards implementing a computer aided production management system. Case H and G were taking a process view using cellular manufacturing as an enabler, Case I was using the EFQM approach - The business

excellence model was used to identify key business enablers which included the manufacturing process. This incorporated the continuous improvement philosophy, and the manufacturing engineering process which incorporated a journey from learner to world class for each manufacturing business. Each manufacturing business reports on their progress monthly, which enables the sharing of best practice throughout the organisation. Case J was implementing lean manufacturing, cells, a benchmarking programme and moving towards a business process focus.

10.4.4.5.3 Knowledge-based manufacturing strategy-making system

Only one organisation (Case I) was implicitly following a knowledge-based approach. Case I identified the core competencies that were required within each location of the organisation, which were mapped onto future market requirements to provide a tiering system throughout the organisation. Each manufacturing tier corresponded to a tier within the value chain. The make or buy element of manufacturing strategy was built around the identification of current competencies and which of these would be kept in house as strategic competencies.

10.4.4.5.4 A hybrid

Case I appeared to be attempting to address all three approaches at the same time, and were experiencing difficulties due to the orientation of the organisation to one of projects processes and functions.

The market led / customer focussed manufacturing strategy-making system was linked to the customer projects manufacturing processes. Manufacturing strategy making for a major new project used the concepts of order winners and order qualifiers to align the new manufacturing processes required to deliver the performance required by the

customer. Delivery reliability was identified as key and the manufacturing system was developed using lean manufacturing as the philosophy.

Within Case I, the three archetypes appear to fall into a manufacturing strategy hierarchy. The knowledge-based approach was used to set the main direction for each manufacturing tier within the business. The market led/customer focussed approach was used within individual projects to align products to the customer requirements. The best practice approach was used within internal supply to continuously strive for greater efficiency. The knowledge-based manufacturing strategy-making system was linked to the manufacturing engineering discipline.

The customer-focussed aspects are linked to individual projects and businesses within the supply chain, the best practice elements are linked to operational effectiveness and the knowledge-based elements are linked to the manufacturing discipline.

10.4.4.6 Inferences from findings of the cases and the manufacturing strategy-making systems

The inferences that can be made from the analysis of case to manufacturing strategy-making system are:

- The best practice approach is the most used
- The knowledge-based approach is still in its infancy in terms of use by the aerospace practitioner
- The market led / customer focussed approach is not being used to the full potential
- The participation of key stakeholders outside of manufacturing is not widespread

- All three views of manufacturing strategy have been used in case I, but require further refinements in a holistic approach which can integrate all three views would be beneficial.

10.4.4.7 Summary of key findings and results

All of the organisations fall into the best practice archetype of manufacturing strategy and are doing so successfully. However these organisations do not seem to be aware of the potential of combining the archetypes to consider other aspects such as the learning organisation and identification of order winners and order qualifiers. The notable absence of any formal method to bring the three archetypes into focus and to enable organisations to evolve using manufacturing strategy suggests a need for a modified approach.

There are several possible reasons why there is a mismatch between the literature (the three manufacturing strategy archetypes) and the cases (the conceptual models).

These are included below:

1. Current manufacturing strategy archetypes are not well known. This is supported by the evidence that the majority of cases follow a best practice approach as opposed to a customer focussed / market led and knowledge-based approach. Government literature is all about best practice.
2. Current manufacturing strategy archetypes need to be modified for the aerospace industry due to the evolution characteristics of the industry such as the move to Integrated Product teams, Concurrent engineering, and a business process focus. This is supported by the experiences of Case I who have started considering the three

approaches and are having difficulty in addressing the difference viewpoints held within the manufacturing organisation.

3. The move of organisations from a functional orientation to a business process focus may require a change in emphasis. A manufacturing strategy making process which enables debate and a shared understanding to develop could be very useful in overcoming barriers to the implementation of the strategy at the formulation stage. This is supported by the experiences of Cases E, H, and I who have articulated the need to expose different points of view to understand why certain trade offs may have to be made.
4. Current methods used by industry should have a strategic focus. The methods should be linked to corporate strategy, which does not happen in all cases. This may be due to the evolution of manufacturing within aerospace and the status of manufacturing as being perceived as the 'underdog' compared to technical - design and marketing functions. This is supported by number of cases that do not have a formal process for formulating a manufacturing strategy and have experienced problems in aligning their change programmes to the corporate and or business objectives.
5. From several of the cases the current methods have broken down due to the different worldviews held by several or more of the key stakeholders within the manufacturing strategy formulation process. In Case E, the marketing manager and the chief engineer had differing views as to what manufacturing should deliver in order to support the business - therefore it was difficult for the process to continue. In Case I, the project manufacturing managers, the process manufacturing managers and the discipline manufacturing managers all had different views as to what manufacturing should deliver. The problems arose when the three different viewpoints could not understand

the position of each other, which led to stresses within the organisation. A soft systems approach would help to overcome the differences as these points of view are explicitly stated within the root definition.

The following stage proposes several changes that could be incorporated into current manufacturing strategy formulation methods, to address the opportunities for improvement identified above.

10.4.5 Stage Six - identification of feasible and systemically desirable changes to current manufacturing strategy-making systems

From the above results, any modified approach should incorporate the following points:

- A balanced systemic view of manufacturing's contribution to the organisations' competitiveness should be taken due to the emergence of three possible views of manufacturing. These three views are the customer project view, the business process view, and the development of the manufacturing discipline. This is strongly apparent from Cases I and E.
- The method should bring together current practices into a common framework, which is applicable to practitioners needs, to enable the benefits from all the three archetypes to be realised and aligned, not solely the best practice archetype which is used in all cases.
- The method should enable the different worldviews of manufacturing within the organisation to be exposed, debated and incorporated to ensure any change programme initiated as an outcome of the manufacturing strategy formulation process is fully accepted and owned by all stakeholders. This is supported by evidence provided by Cases E, I, and H.

- The integration of the three manufacturing strategy archetypes to enable a balanced systemic, approach which incorporates the customer, industrial best practice and the core competencies and capabilities encapsulated within the people, process and technology aspects of a human activity system within a manufacturing environment. This may be similar to the “transformation” quality management archetype identified by Tranfield (1995), that takes a ‘helicopter’ perspective.
- Taking a systemic (holistic) approach in order to understand the implications and dependencies on the wider system (the organisation), and also on the supply chain of the aerospace industry.
- Test and develop the idea of the manufacturing strategy-making system as a cycle of learning in order to ensure a long term view is encouraged, and the concepts of the learning organisation are embedded within manufacturing. To enable the organisations who have taken an emergent approach to incorporate the cycles of learning.
- Identification of the need to identify the stakeholders in the process and their world views of manufacturing in order to enable a smoother implementation of the manufacturing strategy by removing ambiguity and to introduce transparency into the process to ensure problems encountered by case E, F, G and I may not occur.
- Identification of the need to identify the cultural issues such as power, process owners, culture, roles, values and norms and how it all affects the needs of a business process focussed organisation. It is the people who must implement and enable the systems which are developed to achieve the strategic stretch goals. The manufacturing system encapsulates human activity systems as well as designed physical and abstract systems. This is shown in all cases.

10.4.6 Implications of using a soft systems approach to develop a manufacturing strategy

In order to assess the implications of using a soft systems approach, each archetype is explored to expose the potential benefits and drawbacks of using soft systems thinking.

10.4.6.1 Market led / customer focussed approach to manufacturing strategy

The main benefit for taking a soft systems thinking approach in the development of a market led approach to manufacturing strategy is the exposure and debate of different worldviews. This is apparent from Case study A, E and I where the manufacturing view and marketing view are exposed and consensus is reached. This provides a firm basis for building consensus on the required outcomes of the manufacturing strategy-making system, which in turn removes certain barriers to implementation,

10.4.6.2 Best practice approach to manufacturing strategy

The main benefit for taking a soft systems thinking approach in the development of a best practice approach to manufacturing strategy is the exposure and debate of different worldviews. This is apparent from case study L which has taken the best practice approach and has a configuration of an organisation which is striving for excellence in its people, processes and technology. However problems have occurred because the organisational structure is split between processes, projects and disciplines with each having a different view of how manufacturing should evolve to become a World Class Manufacturing organisation. The identification of these world views and the principles of systemicity and

debate has gone some way to resolving some of the conflicts which have arisen from these parts of the organisation having different objectives.

Another benefit of using soft systems thinking in developing a best practice approach to manufacturing strategy is achieved by the use of systems theory to show the integration and relationships between the people, process and technology aspects of the manufacturing organisation.

10.4.6.3 Knowledge-based manufacturing strategy approach

The main benefit for taking a soft systems thinking approach in the development of a knowledge-based manufacturing strategy-making system, is that it takes into account the cultural aspects of a system as well as the systems parameters and concepts used to develop the conceptual models. This is important when considering skills and knowledge created and retention especially when the strategy of the manufacturing organisation is built around the successful development and integration of core competencies to give a strategic advantage.

The benefit of using soft systems thinking in developing a knowledge-based approach to manufacturing strategy is that the approach relies heavily on the human aspects of the manufacturing system and the concept of the learning organisation. SSM was developed to address 'ill defined and messy' problem situations, which are characterised by being human focussed.

10.5 Discussion

The above analysis has provided a foundation to develop a modified approach to the formulation of a manufacturing strategy. The analysis has been done by developing three manufacturing strategy-making systems from three archetypes and comparing these

systems with empirical data. This was to ensure that any modified approach is useful to the operations management practitioner. The use of systems theory has provided a common language to compare the empirical data and the conceptual models of three manufacturing strategy-making systems.

The next chapter describes the development and validation of a modified approach based on the feasible and systemically desirable changes identified in this chapter. This approach was incorporated into a workbook to enable the testing of the ideas. The SSM approach has been identified as an appropriate method to be used as a basis for the development of the workbook. The workbook was validated with several of the case companies to test the criteria laid down in Chapter Two - the usefulness to practitioners, and to determine whether the approach provided a useful template for developing a manufacturing strategy.

11 Chapter Eleven - Development of 'a modified approach to the formulation of a manufacturing strategy' using systems thinking (Cycle Three)

The preceding chapter described the second cycle of learning using soft systems methods of the experiences of seven UK aerospace organisations and their approach to manufacturing strategy formulation.

Each case provided a manufacturing strategy-making system to enable comparisons to be made. These comparisons reinforced the initial empirical evidence provided in phase one of the research, that current manufacturing strategy methods were not being used to their full potential. This provided opportunities for improvement to the current archetypes to support the changing environment that is the UK aerospace industry.

These opportunities for improvement have been incorporated into a modified approach to the formulation of a manufacturing strategy that takes a systemic view of the organisation, environment, and methods at hand.

11.1 Objectives

This chapter describes the need for a modified approach to the manufacturing strategy formulation process based on the needs of the practitioner and outlines the general requirements for a manufacturing strategy-making system based on the two cycles of learning described in the previous four chapters. The approach and its development are described and the mechanism used to deliver the approach is outlined. The validation of the approach is summarised and the chapter concludes with a discussion on the continued development of the approach, which will seek to address issues that have arisen from the validation activities.

11.2 The need for a modified manufacturing strategy approach

The need to develop a modified approach to the formulation of a manufacturing strategy making process has been identified from the manufacturing strategy literature and the empirical cases that incorporate the view of the industry through the practitioners.

11.2.1 The literature

The literature is fragmented into three approaches, which have been identified in Chapter Three, which is reinforced by the views of Voss (1995). The three way split into the market focussed, best practice and increasingly focusing on core competencies as a way of improving the competitiveness of an operations based organisation needs to be addressed to provide the practitioner with a systemic approach to the formulation of a manufacturing strategy. This is reinforced by one of the outcomes of the 5th European Operations Management Association conference that identified that the field of operations management and manufacturing strategy, as the driving force behind operations change is split.

It appears logical to propose that an integrated, holistic and systemic approach would provide a balanced view of manufacturing strategy formulation. This suggests that to develop the people, process and technology elements within the overall manufacturing system would provide a better way to provide an organisation with a competitive advantage. A common language to describe the three elements above would be beneficial and remove ambiguity and would provide practitioners with a balanced choice. Finally a method which allows all of the benefits of the three approaches to be realised would be beneficial.

11.2.2 The UK aerospace industry

The UK aerospace industry is evolving towards a business process focus (SBAC, 1998), which will become even more apparent when the industry recognises the benefits to be gained from looking at the entire value chain. This has implications for manufacturing strategy approaches as the integration of single functions into multi disciplinary teams will incorporate different world views which will require exposure to ensure the manufacturing strategy formulation process provides a strategy which is shared and understood. The emergence of organisations which have a process, project and discipline element involved in manufacturing operations will also have a similar need for a process which takes into account these views to enable a smooth implementation of any strategy outcome.

11.2.3 The empirical cases

The cases have provided evidence that most manufacturing strategy tends to be emergent in nature and is still firmly ensconced within the hard systems paradigm that is the objective is assumed and only one worldview is incorporated into the development of the strategy. The best practice approach to manufacturing strategy formulation is preferred by the industry which is evident from the cases and it still appears that manufacturing is reacting to corporate and business strategy as opposed to forming it. To enable manufacturing to realise the competitive potential that it can deliver, an approach which enables organisations to consider best practice as well as the market led and knowledge-based approaches to give a balanced and systemic view of manufacturing's contribution to the competitiveness of the organisation is needed.

11.2.4 The practitioners

The practitioners have indicated that they require a process which allows them to understand the current context of manufacturing around the factors of people, processes and technology. They also wanted a better understanding of how manufacturing can support corporate and business strategy but also to be able to shape it. This was supported by Case I who were continually being asked to drive changes through the organisation from the corporate level whilst trying to drive best practice through from the operational level. The practitioners indicated the importance of a customer focus and of understanding the boundaries within their influence. The need to understand different points of view of the numerous stakeholders and power holders within manufacturing was highlighted as being important, especially when planning the stretch goals and direction of the manufacturing organisation.

11.3 Summary of requirements for a manufacturing strategy making process

From the above results, any modified approach should incorporate the following points.

- A balanced systemic view of manufacturing's contribution to the organisations' competitiveness should be taken due to the emergence of three possible views of manufacturing. These three views are the customer project view, the business process view, and the development of the manufacturing discipline. This is strongly apparent from Case I who need to address these three views simultaneously, and were experiencing difficulties in doing so.
- The method should bring together current practices into a common framework, applicable to practitioners' needs, to enable the benefits from the three archetypes to be realised and aligned.

- The method should enable different worldviews of manufacturing within the organisation to be exposed, debated and incorporated to ensure any change programme initiated as an outcome of the manufacturing strategy formulation process is fully accepted and owned by all stakeholders.

11.4 The development of the approach

The approach was developed over 12 months and evolved using systems thinking, the manufacturing strategy literature, using Checkland and Scholes soft systems methodology as a frame, and the empirical data described in the previous chapter. The approach has evolved with the assistance and validation activities of three organisations (Cases L, M and N) to ensure the approach is applicable to practitioners and in a format which is practical to use. The approach has been delivered by a facilitator, however further refinements will be made to make the approach more accessible and to be usable without a facilitator. A road map of the approach is shown in Figure 25.

11.5 The Approach

The Road Map

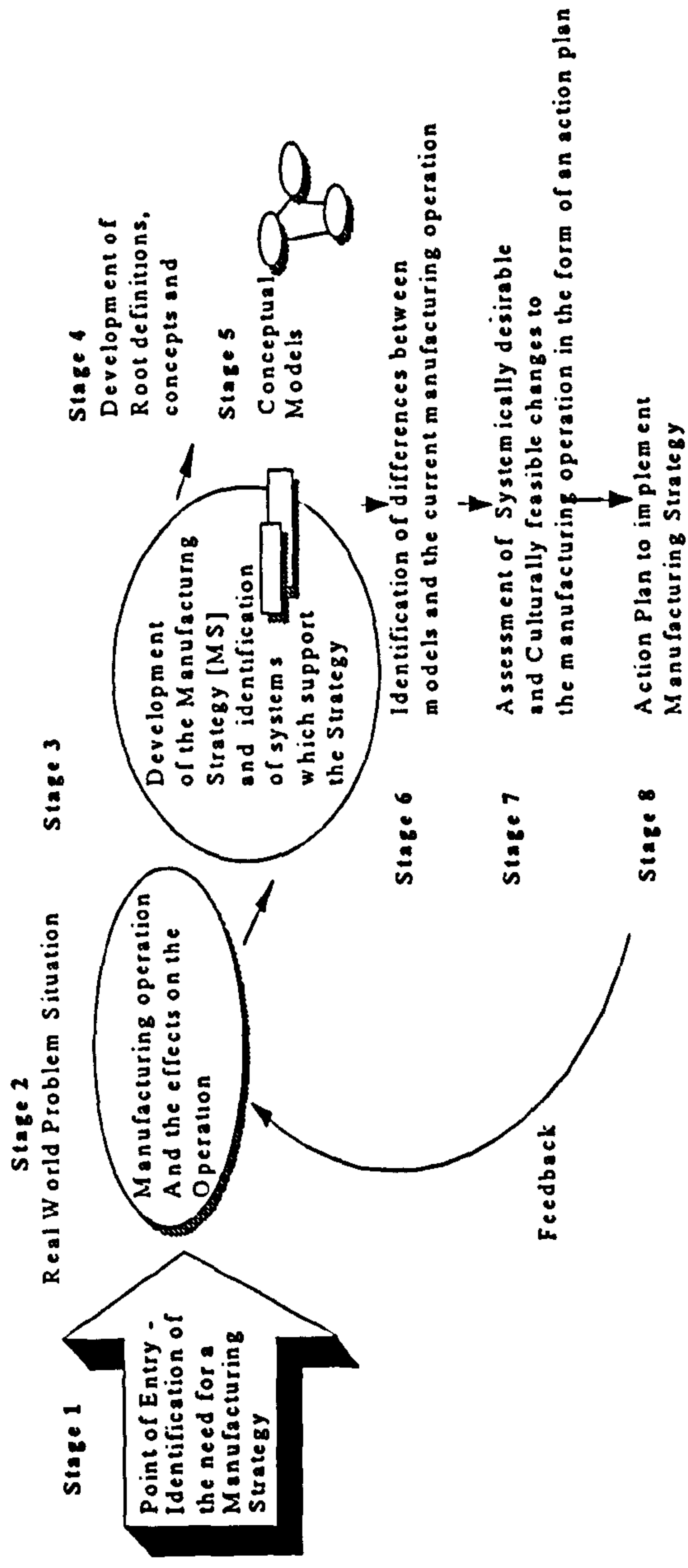

Figure 25 – A soft systems approach to the formulation of a manufacturing strategy

11.5.1 Stage One – does the organisation see the need for change?

Stage one of the approach is described as the point of entry (Platts, 1993) which provides the trigger for initiating the manufacturing strategy making process. This stage will provide the analysis that establishes the need for a manufacturing strategy. The objective for the stage is to identify the need for change and to gain commitment from the relevant stakeholders. This is done to ensure the team is set up with sufficient resource in terms of time and people in order to carry out the process.

11.5.2 Stage Two – the manufacturing organisation and its effect on the competitiveness of the organisation

The objective of stage two of the approach is to enable the practitioner to develop an understanding of the situation of the manufacturing operation and its influences which include the environment, customers, products, suppliers, competitors and problems. The practitioner questions the current business strategy and manufacturing's contribution to achieving the targets set in the business strategy. The approach then leads the practitioner through the process of understanding the current manufacturing organisation, assimilating data from the key stakeholders, reaching consensus on contentious issues and producing a shared understanding of the current manufacturing operation. This incorporates the market led /customer focussed issues into the process to ensure the issues are considered.

11.5.3 Stage Three – the problem situation – development of the manufacturing strategy

The objective of stage three is to develop the manufacturing strategy, stating the direction the manufacturing operation wishes to go in and identifying the relevant systems which can be people, process or technology based, which will support the objectives identified. Stage three develops a statement of what is expected from the manufacturing

organisation, linked to the business strategy and a discussion of the appropriate manufacturing strategy archetypes which could be useful and fit their particular organisation. Objectives are developed from the manufacturing strategy statement.

In stage three relevant systems which may be people based, process based or technology based (or a mixture) which will have a significant role in achieving those objectives are identified. These systems may or may not exist at this stage.

11.5.4 Stage Four – development of the root definitions for each relevant system

The objectives for stage four are to identify what each system identified should do and achieve in order to enable manufacturing to become competitive and to develop a root definition for each system identified and for each world view identified in order to capture and expose any differing views. The systems identified are developed into root definitions in Stage Four, which focus the practitioner in defining exactly what the system is to deliver.

11.5.5 Stage Five – development of conceptual models

The objectives for Stage Five are to develop the conceptual models to satisfy the root definitions derived in stage four. The root definition or root definitions depending on the number of key stakeholders identified are used to develop conceptual models based on the different world views expressed by the stakeholders in stage five. The practitioner is provided with three manufacturing strategy-making systems to determine which approach or a hybrid of the approaches will aid them in achieving their objectives.

11.5.6 Stage Six – comparison of the conceptual models with the real world situation

The objectives of stage six are to compare the conceptual models derived from the root definitions with the real world situation to provide a set of strategic issues which need to be addressed to enable manufacturing to support or drive the business forward. In Stage Six the conceptual models are compared with the real world situation to identify systemically feasible and desirable changes to the current manufacturing organisation in line with the business strategy and manufacturing objectives.

11.5.7 Stage Seven – identification of feasible changes delivered as an action plan.

The objective for stage seven is to provide an implementable manufacturing strategy which will support business and corporate objectives, and be systemically and culturally desirable. Stage Seven leads the practitioner through an assessment of systemically desirable changes to the manufacturing organisation through a series of discussions and debate to reach a consensus with the other stakeholders.

11.5.8 Notes for implementation

Stage Eight delivers an action plan to implement the manufacturing strategy. At this stage the practitioner is encouraged to see the approach as a cycle of learning and is led back to Stage Two to provide feedback to the system. The process then continues cyclically.

11.6 Delivery

The mechanism chosen to deliver the approach was a facilitated workbook that was tested and validated in two aerospace organisations and one SME, using the criteria that

research should be useful to practitioners within the production and operations management domain. The workbook is presented in Appendix Three.

The approach is seen as a cycle of learning which enables the manufacturing organisation to take a balanced systemic view of manufacturing's contribution to the organisation's competitiveness, and allows the manufacturing strategy to emerge as part of the organisations learning activities. The method brings together current practices in a common framework, which is applicable to practitioners' needs and enables the different worldviews of manufacturing within the organisation to be exposed, debated and incorporated. The approach satisfies the criteria for the aerospace industry need for a manufacturing strategy described in section 11.3. The aims of the approach are summarised below:

- To encourage all stakeholders to participate in the process of formulating the strategy.
- To develop an implementable manufacturing strategy taking into account the different worldviews of the manufacturing stakeholders and by using the principles of systemicity and debate to encourage learning and aid in the implementation of the emergent strategy.
- To promote a better understanding and consensus to be reached by exposing the worldviews or perspectives held by the stakeholders during the development of the root definitions for the proposed manufacturing systems.
- To take a systemic view of the manufacturing operation and
- To enable learning to occur about the relevant systems under analysis.

Three manufacturing strategy-making systems are introduced as a guide to understand the current mindsets within the organisation and to act as a catalyst for change if appropriate.

11.7 The workbook

The workbook is divided into five sections, and has been developed to be used with a facilitator. Section One introduces the theoretical base to the approach. Section Two contains the main body of the approach and contains directions and templates to guide the practitioner through the methodology. Section Three contains a glossary of the systems terms used within the approach. Section Four provides an opportunity to provide feedback. Section Five incorporates a conceptual model of the approach in IDEF0 format.

11.7.1 Section One – the theoretical base

Section One introduces the theoretical base of the approach, that is, the underlying principles which have been incorporated into the approach and have been used to develop the approach. These principles include manufacturing strategy and soft systems thinking. Section One aims to set the scene of the approach and gives the practitioner a basic grounding in the key principles. The objective of the approach is presented which is:

‘to develop and evolve an implementable manufacturing strategy taking into account the different worldviews of the process stakeholders and by using the principles of systemicity and debate to encourage learning and aid in implementation’ This can be found in Appendix Three pp 5.

The section outlines the benefits of using the approach which include stakeholder participation, exposure of different perspectives, taking a systemic view of operations, enabling learning to occur and the use of three manufacturing strategy archetypes. The section concludes with a list of issues to be considered whilst following the approach. These issues include identifying the key stakeholders in the manufacturing strategy formulation process, considering who has authority within the process, and identifying the process owner.

11.7.2 Section Two – the soft systems approach to manufacturing strategy

Section Two provides the approach and templates for the soft systems approach to the formulation of a manufacturing strategy. A road map is provided to guide the practitioner and facilitator through the stages. At each stage the relevant segment of the road map is presented together with objectives for each stage and deliverables for each stage.

11.7.2.1 Stage One – does the organisation see the need for change?

The objective for this stage is to identify the need for change and to gain commitment from the relevant stakeholders to carry on with this process. Each stage has several tasks with recommended tools and techniques to complete the task with relevant templates. These are supported with a list of necessary participants and possible sources of information. The manufacturing strategy formulation process owner and key manufacturing stakeholders within the organisation are identified. This enables the team to be set up.

The second task identifies the business strategy. This is achieved using a questionnaire format which encourages debate. The third task identifies the current perception of manufacturing within the organisation as defined by Hayes and Wheelwright (1984). Task four asks the team to identify and explicitly state the manufacturing strategy, the team is then asked if this strategy is adequate in meeting the strategic business objectives.

The team is then given 3 choices: to do nothing if they have a manufacturing strategy which supports business strategy, move to stage two if they want to develop a manufacturing strategy or develop a competitive profile (Platts, 1992) to show any mismatch between market requirements and achieved performance. A summary of what has been achieved at each stage is included.

11.7.2.2 Stage Two – The manufacturing organisation and its effect on the competitiveness of the organisation (the real world problem situation – unstructured)

The objectives of stage two are to develop an understanding of the current situation of the manufacturing operation and its influences, including the environment, key issues concerning customers, products, suppliers competitors and problems.

The completion of these objectives are supported with several tasks. The first asks the practitioner to complete a questionnaire which captures the current understanding of the manufacturing organisation. The questionnaire is completed by the stakeholders identified in the previous task. The information is collated and debated to ensure a common understanding is reached by the stakeholders. A rich picture is then developed to show the shared understanding of manufacturing at this stage.

11.7.2.3 Stage Three – The problem situation – the development of the manufacturing strategy? – what do we want manufacturing to achieve and how do we want the relevant systems to support it?

The objectives of stage three are to develop the manufacturing strategy by stating the direction the manufacturing organisation wants to go in and identifying any relevant systems which will support the objectives identified. These objectives are supported by several tasks. Task 3.1 enables the practitioner to develop a statement of what the organisation expects of manufacturing. Task 3.2 provides a questionnaire which aims to stimulate debate around three manufacturing strategy-making systems which were developed in Chapters Seven, Eight and Nine.

Task 3.3 guides the practitioner in identifying which systems within manufacturing will have a significant role in achieving or supporting the objectives identified earlier. These systems may or may not exist at this stage. Examples of possible systems are given in the workbook.

11.7.2.4 Stage Four – the development of the root definition for each relevant system selected in stage three.

Following the development of objectives and the naming of relevant systems, the objectives of stage four are:

- to identify what each system should do and achieve in order to enable manufacturing to be competitive and
- to make the thinking explicit for each relevant system by developing a root definition (please refer to Chapter Six) for each world view held by the stakeholders. This stimulates debate around key issues and exposes any differing views.

The tools and techniques to support this are using Checklands (1992) root definition form ‘a system to do x by means of y in order to achieve z’ and CATWOE which defines the customers, actors, transformation, worldview, owner and environment for each system identified. A detailed description can be found in Chapter Six.

11.7.2.5 Stage Five – the development of conceptual models derived from the root definitions from each relevant system

The objectives of stage five are to develop conceptual models to satisfy the root definitions developed in stage four. The practitioner is guided through this stage with several templates for the root definition and other systems parameters which are useful in

describing a system. The templates guide the practitioner to 3 levels of decomposition for the models.

11.7.2.6 Stage Six – Comparison of the conceptual models to the real world situation

The objectives for stage six are to compare the conceptual models derived from the root definition with the real world situation to provide a set of strategic issues that need to be addressed to enable manufacturing to support business and corporate objectives. This is achieved by using comparison tables which are included as a template within the workbook.

11.7.2.7 Stage Seven – identification of feasible and desirable changes to the manufacturing strategy system – output – the direction of the manufacturing system – the manufacturing strategy

The objectives for stage seven are to provide an implementable manufacturing strategy which will support business and corporate objectives and is systemically and culturally desirable and feasible. This is achieved through debate and the development of an action plan which is facilitated with a template which identifies goals, the link to the manufacturing strategy, timescales, resources, responsibilities and team members.

11.7.3 Section Three – Additional information

Section Three provides a glossary of terms used in the approach. The section provides definitions of the systems terms (Checkland, 1991) used to develop the approach and the root definitions. Terms include the ‘real world, rich pictures, problem situation, root definitions, CATWOE, and conceptual model’. The aim of Section Three is to

provide the semantics to aid the practitioners understanding of the concepts underpinning the approach.

11.7.4 Section Four – feedback of approach

Section Four provides an opportunity for feedback of the process to enable further development. This is presented as: a questionnaire which asks the practitioner about the outcomes of the approach, the usability of the approach and whether the approach is seen as useful.

11.7.5 Section Five – process model of the approach

Section Five provides an IDEFo model of the approach. This enables the practitioner to use the model as a check sheet to ensure all relevant information is collected and analysed in the correct sequence. The model can also be used to explain the process to practitioners.

11.8 Validation of the approach

The approach is the culmination of research into the current uses of manufacturing strategy techniques within the UK aerospace industry. This identified a need for a modified approach to the formulation of a manufacturing strategy due to changes in the industry structure, changes in market conditions and the proliferation of best practice. The need for a modified approach is based on the evolution from a functional organisation to a business process focus and all the integration and cultural problems that fall out of the change.

Business processes owners will need to align their people, processes and technology to the business and corporate strategy in order to enable the organisation to develop in step with customers' needs and changing competitive conditions. The approach

was developed to aid in identifying and embedding different perspectives which would be pulled together from the original functions and would be required to work together in ensuring the implementation of any changes are understood and accepted. This ensures that the perspectives are not hidden and are therefore not an unknown influence in the implementation.

The validation of the research is based on whether the approach is deemed useful by aerospace operations practitioners and their response to the approach. The validation and evolution of the workbook have gone hand in hand over six months where the workbook has been repeatedly refined and tested. The approach has been modified three times to date. Several different approaches have been taken to validate the workbook. These have included working with practitioners to refine, develop, and use the workbook and with academics to test the academic rigour.

11.8.1 Validation through use

The workbook was introduced to practitioners over twelve months, which provided invaluable advice, opportunity to test and validate the approach. Three organisations were involved in testing and developing the approach. These will be denoted as Case L, M and N.

11.8.1.1 Case L

Case L was involved with the research from the outset and provided a safe environment to explore ideas, approaches and to progress through the workbook step by step. The validation of the workbook took place over three focus group meetings. The focus group consisted of the author, the chief engineer, the research and development manager, the marketing manager, one other researcher from another institution, manufacturing engineers and representatives from purchasing.

The meetings were used to go through each section of the workbook, activity by activity. This was extremely helpful as the author was asked to explain and justify the flow of the workbook, the participants, the sources of data, the concepts underpinning the workbook and the frames and templates provided. Major structural changes were made following these meetings which proved to be invaluable. The following comments were received during and after the development programme.

“it was useful to focus on general business issues and manufacturing issues to develop the understanding of how the manufacturing strategy should evolve”

“the templates included in the workbook are useful”

“see the relevance in using soft system theory in the manufacturing strategy formulation process”

“it is important to realise there is a problem situation”

“the workbook is seen as useful”

“the grounding theory was solid, at the right level and relevant”

“approach applicable to other industries as well as aerospace”

Statements and summaries of the meetings are included in Appendix Three.

11.8.1.2 Case M

Case M was involved for the last six months of the research, which provided a new environment to test ideas and the approach with a new set of eyes and ways of thinking. The validation was initiated with several meetings to describe the approach and the approaches’ benefits. The result of this was the running of a full day workshop during which the workbook was completed by the team of a manufacturing engineering manager, a supply chain manager, and the author. This was again invaluable feedback and raised several issues that were subsequently addressed as to the descriptions and

preunderstanding required for the approach. It was agreed to take the process further by involving the senior management team on a workshop run over several days.

Further workshops were held to continue the development and a sixth month work placement was carried out as part of the validation of the ideas and approach. Details of the workshop and the feedback from the team are included in Appendix Four.

The following comments were received during and after the development programme.

“we are convinced that this approach has considerable merit”

“a shared understanding can be developed”

“conflict and political issues will be key to manage the process”

“good tool to understand the process of manufacturing strategy”

“stimulates discussion”

“provides a thread to lead the team from the business issues through to a manufacturing strategy”

11.8.1.3 Case N Case N was involved in the last four months of the research and was an SME based in the West Country. The approach was tested to the full during a series of six workshops and provided valuable insight into how the approach could be developed to be applicable to SMEs and other sectors of industry. The people involved in this validation include the manufacturing director, the marketing manager, and the author. The feedback from the workshops was extremely positive and is included in Appendix Four. The company felt the approach had several key benefits. These included the exposure of different world views as to what manufacturing should deliver, the principles of debate, systemicity – to provide them with a systemic view of the whole business, and the development of the systems which would enable them to meet their stretch goals. Work with this organisation is ongoing. The following comments were received during and after the development programme.

“the model framework has allowed us to address the present systems condition within the company from a clear viewpoint”

“feel that using the model we have achieved a much more impartial and focussed view of the company, aligning current perceptions and views with the framework”

“useful to talk through the issues and to understand the different approaches of manufacturing and marketing”

11.8.2 Validation through debate

The workbook was also validated through discussions with academics who were familiar with soft systems approaches. These debates again provided useful insights into the approach and developed the workbook further. Comments are included in Appendix Four under ‘additional comments’.

The comments included: “is there a rich picture for the approach”.

11.9 Future development of the approach

It is proposed to further develop the workbook after the initial comments from both practitioners and academics. The approach will be incorporated into an EPSRC research grant which is developing a methodology for process based change. This will enable further testing and refinement.

Other academic institutions will also be involved in the continued development of the use of soft systems in manufacturing strategy formulation which should form a rich source of experience and data to further develop the soft systems approach to the formulation of a manufacturing strategy.

11.10 Discussion

This chapter has described the approach and the validation of the approach. Responses to date have been encouraging and meet the criteria used to determine if the research output is successful. The workbook has been identified by the validation practitioners as a useful and valid approach to looking at the problem situation of how the manufacturing operation can be used to improve the competitiveness of the organisation.

The final chapter will sum up the research project and reiterate the contribution to the operations management field of research.

12 Chapter Twelve – Discussion and Conclusions

The previous chapter introduced a modified approach to the formulation of a manufacturing strategy, using a workbook as the mechanism. This modified approach is the main contribution of this work to the field of manufacturing strategy. The modified approach has been developed to be applicable to aerospace organisations moving from a predominantly functional orientation towards a business process focus.

This chapter will present the conclusions from the research and will identify how the field of production and operations management has changed. The chapter will conclude the research findings and outline recommended further research.

12.1 Introduction

This work has provided a modified approach to the process of manufacturing strategy formulation, which should lead to the development of a usable and implementable manufacturing strategy. The approach takes a systemic view that incorporates different viewpoints into the formulation process and allows the key stakeholders to come to an accommodation through debate and the use of conceptual models.

The process of manufacturing strategy formulation is described as a messy situation, which will benefit from the use of a soft systems approach. This approach allows culturally feasible and systemically desirable changes to be made to the manufacturing operation and is seen as a learning process of enquiry. The approach has been developed using current literature, which has been expanded to develop three manufacturing strategy archetypes using systems thinking. The approach has taken into consideration the experiences of seven UK aerospace organisations and has developed with the learning resulting from the empirical data. The approach was validated for usefulness to practitioners using a workbook as the mechanism. The validation process was

extremely beneficial in developing the approach and the feedback was predominantly positive.

The purpose of the chapter is to critically evaluate the research process chosen and to consider the usefulness of the research. The contribution of the work will be expanded and further research directions recommended.

12.2 Research problem

The research problem originated from developing ideas surrounding manufacturing strategy and framing those ideas around organisations which had embarked on radical change programmes encompassing a business process focus. The research developed into an evaluation of current manufacturing strategy methodologies with the objective of determining whether the methods were appropriate for business process focussed organisations. This led the research into the UK aerospace industry and exposed the researcher to a large number of issues that impact on the competitiveness of the industry.

Several stimuli (as described in Chapter Two) have caused the competitive environment of the industry to change dramatically. Over the past decade the procurement policies of the major defence customers have radically changed. Defence contractors who were used to operating under cost plus conditions were faced with contracts that were based on a fixed price with fixed milestones. Missed milestones led to severe penalties on the supplier. This radically changed the way the manufacturing operation could and should function. Order winners and order qualifiers were changed from quality at any price, to delivery reliability and quality at the fixed price agreed in the contract. The industry responded by embarking on major restructuring programmes. These programmes were based on meeting these requirements.

Functionally orientated organisations embraced the principles of BPR and embarked on ambitious change programmes. These events brought together concurrent

engineering teams from functions which used to operate on the 'over the wall' type of engineering philosophy. The importance of aligning corporate and business strategy to the functions or business processes became apparent. The current manufacturing strategy formulation methods did not appear to be used in the majority of aerospace organisations. With the evolution of the aerospace industry and the emergence of the technical function as the most powerful force, manufacturing appears to have been expected to produce what is expected, sometimes without being fully consulted.

The need for a study into current methods and the industry's requirement became clearer. The industry appeared to be wholeheartedly taking up best practices and attempting to implement them without aligning the changes to the business objectives. This was the problem situation that the research was hoping to improve.

12.3 Research methodology

The research methodology emerged into two phases and was built on Meredith et al's (1989) cycle of description, explanation, and testing. Phase one framed and developed the research question set and explored the current literature. Empirical data was added to the picture from three initial case studies of current manufacturing strategy practices within the UK aerospace industry.

The results of the initial research formed the report to transfer from MPhil to a PhD. Phase Two used Meredith et al's (1989) frame and developed it, using Checkland and Scholes' (1990) Soft Systems Methodology as a basis for several cycles of learning and development of ideas. The cycles included the development of three manufacturing strategy-making systems from three manufacturing strategy archetypes using current literature and systems theory to make the thinking explicit.

The cycles continued with the building of a rich source of empirical data from the UK aerospace industry. This looked at the use of current methods and the industry's

requirements surrounding the use of manufacturing strategy, especially with the focus of moving from a functional to a business process orientation.

The third cycle involved developing a soft systems approach to the formulation of a manufacturing strategy delivered through the mechanism of a workbook. This was validated by practitioners and academics and was found to meet the criterion of being useful to practitioners. The research methodology made use of case study research, and collected data from a variety of sources to ensure a rich picture was provided.

12.4 Exploratory research

The exploratory research was initiated to determine if the research question was a feasible and useful problem situation to study. The research question evolved into looking at manufacturing within the aerospace industry and its role in enabling the industry to become / remain competitive. Three questions were used to focus the exploratory research. These included:

1. Are current Manufacturing Strategy methods and techniques used within the UK Aerospace industry?
2. Are the methods and techniques adequate?
3. Are there any opportunities for improvement?

To form the basis and feasibility of the research, a literature survey was initiated to describe the current manufacturing strategy literature and to understand the history and evolution of manufacturing within the UK aerospace industry. This was supported by three empirical case studies that led to the view that the research was worthwhile and should be developed.

The initial case studies did not have any planned manufacturing strategy formulation processes although they realised the benefits of having one in place. The initial results were used to frame the research direction and questions.

The research direction was also shaped by a literature review into systems thinking which helped in the development of the research methodology chosen and in subsequent development of ideas and the soft systems approach finally chosen.

12.5 The development of three manufacturing strategy-making systems

Following the exploratory research, the second phase was initiated by developing three manufacturing strategy archetypes into manufacturing strategy-making systems using systems thinking. It was felt to be a useful part of the research to frame current thinking in this way to provide practitioners with a tool for determining which archetype they are predominately in and to show alternative ways of developing a manufacturing strategy. The alternative approach enabled the practitioners to widen their thinking and to present alternative views, which may be outside their current archetype. The three archetypes were:

- a market led /customer focussed approach to manufacturing strategy
- a best practice approach to manufacturing strategy
- a knowledge-based approach to manufacturing strategy

Each archetype was defined using a root definition and conceptual model to provide three manufacturing strategy-making systems. These systems were then used to analyse the empirical data to provide opportunities for improvement in order to develop a modified approach to the manufacturing strategy formulation process. The linkages between the archetypes were presented as a meta model to enable the practitioner to structure their

thinking depending on which level in the organisation or hierarchy they were concerned with. This was presented in the workbook and in Chapter Nine section 9.7 which showed a summary of the three manufacturing strategy making systems as Table 8. This was strengthened from the experiences of Case I which had elements of the organisation split into the three views of manufacturing.

12.6 The empirical evidence

The results of Phase One reinforced the need to look at the area of manufacturing strategy within the aerospace industry and forty organisations were approached for Phase Two. Nine organisations agreed to participate in the next phase of research. These organisations provided data to develop root definitions and conceptual models of their manufacturing strategy processes and change management processes. These processes were compared with the three manufacturing strategy-making systems developed previously and the gaps between the theory and empirical data were noted and used to develop the potential characteristics required by the aerospace industry for a manufacturing strategy formulation process. These characteristics were tested and validated in a modified approach to the formulation of a manufacturing strategy.

The data was gathered from multiple sources within the case organisations. The method of data collection included structured interviews with key manufacturing stakeholders, minutes from meetings, workshops, focus groups, and company documents. The raw data was developed into the appropriate format to enable analysis and sent back to the case organisation for validation. All organisations were asked if the written up case showed a true representation of the manufacturing strategy processes. Any alterations were included in the final case.

12.7 The need for a modified approach to the formulation of a manufacturing strategy

The following considerations were taken into account when designing a modified approach to the formulation of a manufacturing strategy.

A systemic approach would be beneficial when formulating strategy for a business process to ensure key areas are not missed. Manufacturing is made up of numerous systems including human activity systems, which should be considered when formulating a manufacturing strategy, this is described in Chapter Six. Hard systems theory has been shown to be unsuccessful in developing solutions to messy problems (Checkland, 1981). Therefore a soft systems approach could be more appropriate. This is shown in Chapter Ten and Eleven.

The implementation phase of the development and formulation of a manufacturing strategy is critical and is largely disregarded by researchers (Platts, 1993). Therefore in the process of formulation it would seem logical to bring together key manufacturing stakeholders to ensure a shared understanding is developed of important issues and relevant systems to enable manufacturing to support the business and corporate strategy. This is supported by the empirical data collected from the experiences of seven aerospace organisations of formulating manufacturing strategies

The following have been adopted as key requirements for a manufacturing strategy formulation process based on empirical evidence, current manufacturing strategy methodologies and the evolution of organisations within the UK aerospace industry.

12.8 Manufacturing strategy requirements for UK aerospace organisations

When considering the requirements for a manufacturing strategy, the organisation needs to understand the current manufacturing situation within the business context. This

includes coming to a shared understanding of how manufacturing has evolved within the organisation and where it sits in the power and political structure of the organisation. The relationship to the current corporate and business strategy needs to be expressed and agreed by the manufacturing stakeholders. The current manufacturing strategy should be identified. The major stakeholders should understand and support the need for a manufacturing strategy.

The competitive role of the manufacturing operation should be explored. Trade-offs will be required. No one manufacturing facility will be able to perform everything well (Hill, 1992). Trade-offs and specific decisions with the classic Hayes and Wheelwright (1984) decision areas will be necessary. Questions should be asked about the suitability of evolving from a functional organisation to a business process or project focussed organisation. If a business process orientation or a functional orientation is seen to be beneficial, questions should be asked as to what manufacturing should be doing. Emphasis should be placed on the '*what*' and '*should*'. A statement should be developed as to what is expected of manufacturing. This should be agreed by key manufacturing stakeholders and internal customers. This is important to ensure all stakeholders have a shared view of what is expected of the manufacturing operation to ensure they are all pulling in the same direction. This is discussed in Chapter Ten and Eleven.

The manufacturing operation is made up of many manufacturing systems such as human activity, designed abstract and physical systems. To be able to identify how to develop and evolve the manufacturing operation into a competitive tool, relevant systems should be identified which will promote beneficial changes to the operation. These relevant systems should then be developed in to root definitions which are concise and explicit statements of what the system is supposed to do, by what means and what it is expected to achieve. The root definitions, systems concepts and parameters aid the development of conceptual models which develop a shared understanding of the major manufacturing stakeholders into what the manufacturing operation should be doing in

order to enable the competitiveness of the business. This is done to ensure a systemic view as opposed to a reductionist view is taken, and to reach consensus and a common language between the differing cultures which have an interest in the manufacturing operation.

12.9 Validation of the approach

Following the identification and development of manufacturing strategy characteristics that may be appropriate to the manufacturing strategy formulation process within the UK aerospace industry, a modified approach to the formulation of a manufacturing strategy was developed. The approach made use of systems concepts and soft systems methods and was validated within three organisations and was delivered using a workbook. Each validating organisation reported benefits from using the approach. Case L commented 'it made us think about the taken for granted that are held', 'got us really thinking through the issues', 'gave a direction'. Comments from case M 'it was most useful'. The comments are included in Appendix Four.

12.10 The contribution

The contribution of the work comes from the critical evaluation of existing manufacturing strategy methods and techniques. This evaluation determined that the above were not well enough developed for the evolving aerospace industry. Opportunities for improvement were identified which were incorporated into a modified method for formulating a manufacturing strategy. The method addressed the issues identified.

The method makes use of three manufacturing strategy-making systems, developed using systems theory, to ensure the thinking surrounding the manufacturing strategy is made explicit and is systemic. The mechanism for testing and validating the contribution was a workbook.

The soft systems approach was successfully validated on the criteria of the work being useful to the practitioner and has been identified as being a useful and exciting approach to formulating manufacturing strategy. The approach was developed for use within the UK aerospace industry, however the practitioners involved in the validation believe the approach could be useful in other sectors of industry. The approach will continue to be developed in industry, and as a result has been successfully validated in a non aerospace SME (Case N).

Aerospace organisations are moving towards the extended enterprise model (SBAC, 1998) and therefore will need to see themselves and their suppliers and customers as part of the wider system. A holistic view is necessary, which will enable the organisations to position themselves more appropriately in the forever shifting global market. The soft systems approach fits in well with the emerging knowledge-based view of strategy as it is seen as a learning cycle, which enables organisations to continually adapt to the changing environment. Strategy should be a dynamic, iterative process, which would benefit from the soft systems approach. The evidence for this view is supported from the experiences of several of the case organisations, which benefited from the exposure of the different worldviews that were held by different members of the strategy formulation team. This is argued fully in Chapter Eleven.

The validation by practitioners of the approach has been extremely useful in developing the approach and in reinforcing the need for the approach. It has been well received by the 'host' organisations and will continue to be developed after the completion of the thesis. The approach is an exciting addition to the manufacturing strategy research agenda and should be well placed to enable process-focussed organisations to align their strategies both with their corporate agendas and with the extended enterprise.

12.11 Future research

The soft systems approach to the formulation of a manufacturing strategy will continue to evolve. Future research will explore if any evolution from the market led manufacturing strategy archetype through the best practice model towards the knowledge-based model can be identified. The approach will be introduced to SMEs as part of a wider research programme into BPR and will be modified to the needs of the SME practitioners.

It would have been useful to develop the three manufacturing strategy-making systems further and to identify if any progression between the archetypes occurred. The second phase of the research has used soft systems methods as a frame and as learning cycles. It would also be useful to continue to develop the approach using further cycles of SSM to test the approach and the manufacturing strategy making systems in other industries and in the service sector.

References

A

Ackoff R L (1981) *'Creating the Corporate Future'* J Wiley and Sons New York

Adam E A and Swamidass (1989) 'Assessing operations management from a strategic perspective' *Journal of Management* (15) 2 pp 181-203

Anderson J C, Schroeder R G and Cleveland G (1991) 'The process of manufacturing strategy: some empirical observations and conclusions' *International Journal of Operations and Production Management* (11) 3 pp 86-110

Ansoff H I (1965) *'Corporate Strategy'* McGraw Hill New York NY

Argyris C (1992) *'On Organisational Learning'* Blackwell 1-55786-262-1

Argyris and Schon (1996) *'Organisational learning 2: theory, method and practice'* Addison-Wesley 0-201-62983-6

Armistead C and Machin S (1997) 'Implications of business process management for operations management' *International journal of Operations and Production Management* 17 (9) pp 886 - 898

Armistead C, Harrison A and Rowlands P (1995) 'Business process re-engineering: lessons from operations management' *International Journal of Operations and Production Management* 15 (12) pp 46 - 58

B

BAe Press releases (1997) *"Malaysia And British Aerospace Sign Aerospace Co-operation Agreement"* - Friday, 5 December 1997 <http://www.bae.co.uk/html/if.html>

Berry W L and Hill T (1992) 'Linking systems to strategy' *International Journal of Operations and Production Management* 12 (10) pp 3-15

Bishop P (1997) 'Strategic change in the European defence industry' *European Business Review* 97 (4) pp 162 - 170

Bititci U S, Carrie A S, McDevitt L (1997) 'Integrated performance measurement systems: an audit and development guide' *The TQM magazine* 9 (1) pp 46 - 53

Bititci U S, Carrie A S, McDevitt L (1997) 'Integrated performance measurement systems: a development guide' *International Journal of Operations and Production Management* 17 (5) pp 522 - 534

Boardman J T (1995) 'Wholes and parts – a systems approach' *IEEE Transactions on systems, man and cybernetics* Vol. 25 No 7 July

Bolden R, Waterson P, Warr P, Clegg C and Wall T (1997) 'A taxonomy of modern manufacturing practices' *International Journal of Operations and Production Management* 17 (11) pp 1112-1130

Boyer K (1998) 'Longitudinal linkages between intended and realised operations strategies' *International Journal of Operations and Production Management* 18 (4) pp 356 - 373

Bozarth B (1997) 'Measuring the congruence between market requirements and manufacturing' *Decision Sciences* Winter (28) 1 pp 121-150

Brocklesby J (1995) 'Using soft systems methodology to identify competence requirements in HRM' *International Journal of Manpower* 16 (5/6)

Buffa (1984) '*Meeting the competitive challenge: manufacturing strategy for US companies*' Dow Jones – Irwin, 0-256-03124-x

C

Camp C (1989) 'Bench-marking: the Search for Industry Best Practices which lead to superior performance - parts 1 to 5' *Quality Progress*, Jan-May

Campbell D J and Stanley J C (1965) '*Experimental and Quasi-experimental designs for research*' Rand McNally Chicago

Checkland P (1981) '*Systems thinking, systems practice*' Chichester Wiley 0-471-27911-0

Checkland P and Holwell S (1998) '*Information, systems and information systems : making sense of the field*' Wiley 0-471-95820-4

Checkland P and Scholes J (1990) '*Soft systems methodology in action*' Wiley and Sons

Checkland, Warmingham and Wilson: (1984) '*Research on improving the management of production systems: An approach through systems methodology*'

Childe S J (1994) 'Business Process Re-engineering management Bibliographies and Reviews' (21) 3 pp 2-8

Childe S J (1998) 'The extended enterprise – a concept of co-operation' *Production Planning and Control* (9) 4 pp 320-327

Childe S J, Maull R S and Bennett J (1994) 'Frameworks for understanding Business Process Re-engineering' *International journal of operations and production management* (14) 12

Churchman (1971) '*The design of inquiring systems*' Basic Books NY

Cleveland, Schroeder and Anderson (1989) 'A theory of production competence' *Decision Sciences* Vol. 20 pp 655-68

Codling S (1992) '*Best Practice Benchmarking, Industrial Newsletter*': Dunstable, Beds.

D

Davenport T H (1993) '*Process innovation: re-engineering work through information technology*' Harvard Business School Press - 0-87584-366-2

Davenport T H and Short J E (1990) 'The new industrial engineering: Information technology and business process redesign' *Sloan management review* Summer

Davis S and Botkin (1991) 'The coming of the knowledge-based business' *Harvard Business Review* Sept-Oct

Dawes F (1995) 'Redefining strategy: a core competence approach to linking business and operations strategy' *EOMA Management and new production systems* 28 – 31 May

Deakins E and Makgill H (1997) 'What killed BPR? Some evidence from the literature' *Business Process Management Journal* (3) 1 pp. 81-107

Delbridge R, Lowe J and Oliver N (1995) 'The process of benchmarking a study from the automotive industry' *International Journal of Operations and Production Management* 15 (4) pp 50 - 62

Denzin N K and Lincoln Y S (1994) '*Handbook of Qualitative Research*' Sage

Descartes In Russell, Bertrand (1946) '*History of western philosophy: and its connection with political circumstances from the earliest times to the present*' London: Allen and Unwin.

Draaijer D and Boer H (1995) 'Designing market oriented production systems: theory and practice' *Integrated Manufacturing Systems* 6 (4) pp 4 - 15

Draaijer, Boer, Spina, Bartezzaghi, Bert and Cagliano (1995) 'The new manufacturing paradigm II and performance measures' *EOMA Management and new production systems* 28 – 31 may 116 - 125

E

Earl M J (1994) 'The new and the old of business process redesign' *Journal of Strategic Information Systems* (3) 1

F

Feurer R and Chaharbaghi (1995) 'Researching strategy formulation and implementation in a dynamic environment' *Benchmarking for Quality Management and Technology* 2 (40) p 15 - 26

Filippini R (1997) 'Operations management research: some reflections on evolution, models and empirical studies in OM' *International Journal of Operations and Production Management* 17 (7) pp 655-670

Fine C H and Hax A C (1985) 'Manufacturing Strategy: a Methodology and an Illustration' *Interfaces* (15) 6 pp 28-46

Fine C H and Whitney D E (1996) 'Is the make-buy decision process a core competence?'

Fry T, Steele D and Saladin B (1994) 'A service orientated manufacturing strategy' *International journal of operations and production management* (14) 10 pp 17-29

G

Gill J and Johnson G (1997) '*Research methods for managers*' London Paul Chapman 2nd edition (1st edition 1991)

Glaser, Barney G, Strauss Anselm L. (1967) '*The discovery of grounded theory: strategies for qualitative research*' Chicago Il: Aldine

Greswell T (1996) '*Strategies for manufacturing innovation*' Transfer report

Greswell T, Childe S J, Maull R S, and Bennett J (1995) 'A Two fold approach to manufacturing improvement', *Proceedings of the Twelfth Conference of the Irish Manufacturing Committee*, 6-8th September, University College Cork pp. 429-436

Greswell T, Childe S J, Maull R S, Bennett J (1995) 'Linking Manufacturing Strategy to process improvement' *Advances in Manufacturing Technology IX*, Proceedings of the 11th National Conference on Manufacturing Research 12-14 September, De Montfort University Leicester, pp 656-60

Greswell T, Childe S J, Maull R S, Bennett J, and Campbell N, (1995) 'The role of manufacturing strategy within a Business Process Re-engineering change programme', *Proceedings of the 13th International Conference on Production Research*, Jerusalem, Israel August 6-10, pp 144-146

Greswell T, Childe S, Maull R (1998) 'Three Manufacturing Strategy Archetypes - A Framework for the UK Aerospace Industry' *Strategic management of the manufacturing value chain: working conference of the international federation for information processing working group 5.7* 26-28 August Marine Highland Hotel, Troon, Scotland, UK

Greswell T, Childe S, Maull R, Smart P A (1998) 'The development of three manufacturing strategy-making systems' *Proceedings of the 3rd International conference – Managing Innovative Manufacturing (MIM'98)* University of Nottingham 6 – 8 July

Greswell T, Maull R, Childe S, and Bennett J (1996) 'The linking of manufacturing strategy to business process re-engineering' *Proceedings of the 3rd International Conference of the European Operations Management Association*, 2-4 June, London.

Greswell T, Maull R, Childe S, Nash Z (1998) 'A soft systems approach to the formulation of a manufacturing strategy' *Operations Management future issues and competitive responses papers from the 5th international conference Euroma conference Dublin* pp 207-213

Gummesson E (1991) '*Qualitative Methods in Management Research*' Newbury park, CA; Sage

Gummesson E (1993) '*Case study research in management – methods for generating Qualitative data*' Preliminary script – second revised version - Stockholm university Department of Business Administration

Gupta Y P, Ionial S C and Mangold W G (1991) 'An examination of the relationship between manufacturing strategy and marketing objectives' *International Journal of Operations and Production Management* (11) 10 pp 33-43

H

Hall A D (1962) *A methodology for systems engineering* Van Nostrand NY

Hamel G and Prahalad C K (1989) 'Strategic intent' *Harvard Business Review* May June pp 63-76

Hamel G and Prahalad C K (1993), 'Strategy as stretch and leverage', *Harvard Business Review* March-April pp 75-84

Hammer M (1990) 'Re-engineering work: don't automate, obliterate' *Harvard Business Review* July-August pp 104-112

Hammer M (1996) *Beyond re-engineering: how the process-centred organisation is changing our work and our lives* London: Harper Collins Business 0-00-255643-x

Hammer M. and Champy J (1993) *Re-engineering the corporation: a manifesto for business revolution* New York Harper Collins Publishers

Hanson P and Voss C (1995) 'Benchmarking best practice in European manufacturing sites' *Business process re-engineering and management journal* (1) 1 pp 60 - 74

Harland R P (1994) *Practical benchmarking: closing the gap* presentation

Harrison A (1998) 'Manufacturing strategy and the concept of world class manufacturing' *International Journal of Operations and Production Management* 18 (4) pp 397 - 408

Harrison A and Storey J (1996) 'New wave manufacturing strategies – operational, organisational and human dimensions' *International Journal of Operations and Production Management* 16 (2) pp 63 - 76

Harrison E F and Pelletier M A (1998) 'Foundations of strategic decision effectiveness' *Management Decision* 36 (3) p 147 - 159

Hayes R H and Pisano G P (1994), 'Beyond World Class: the new manufacturing strategy' *Harvard Business Review* January-February pp. 77-86

Hayes R H and Wheelwright S C (1984) *Restoring our competitive edge: competing through manufacturing* John Wiley New York NY

Hayes R H, Wheelwright S C and Clark K B (1988) *Dynamic Manufacturing: creating the learning organisation* Collier Macmillan New York NY

Hesford M (1997) *Competitiveness Challenge Report* SBAC Period 1/9/96 to 31/1/97 <http://www.sbac.co.uk/news/cc-r1.htm>

Hill T J (1985) *Manufacturing Strategy: The strategic management of the manufacturing function* Macmillan London

Hill T J (1989) '*Management Strategy: Text and Cases*' University of Bath Irwin

Hill T J (1991) '*Production/Operations Management: text and cases*' 2nd Ed. Prentice Hall: London

Hill T J (1993) '*Manufacturing Strategy*' 2nd Edition, Macmillan: Basingstoke

Hill T J (1994) '*The Strategy Quest*' Pitman

Hill T J (1996) 'Manufacturing strategy: keeping it relevant by addressing the needs of the market' opening address – 3rd EurOMA Conference June 1996 London and *Integrated Manufacturing systems* 8 (5) 1997 pp 257 - 264

Ho K K J and Sculli D (1994) 'Organisational theory and soft systems methodologies' *Journal of Management Development* 13 (7) pp 47 - 58

Hum S and Leow H (1996) 'Strategic manufacturing effectiveness – an empirical study based on the Hayes and Wheelwright framework' *International Journal of Operations and Production Management* (16) 4 pp 4-18

I

IMI (1996) '*Research framework for IMI integrated aerospace manufacturing programme*' ISBN 1-899371-90-7 (in the SBAC competitive challenge pack)

J

Jick T D (1979) 'Mixing Qualitative and Quantitative Methods: Triangulation in Action', *Administrative Science Quarterly* (24) 4 pp 602-11

Johnson and Scholes (1997) '*Exploring corporate strategy: text and cases*' 4th edition Prentice Hall, Previous ed. 1993 - 0-13-525635-6

Jones (1992) 'Beyond the Toyota production system: the era of lean production'. In *Manufacturing Strategy: Process and content* (Voss C A Ed) pp 189-210 London Chapman and Hall

Jorysz H R and Vernadat F B (1990) 'CIM-OSA Part 1: Total enterprise modelling and function view' *International Journal of Computer Integrated Manufacturing* (3) 3

K

Kant (1781) In Russell, Bertrand '*History of western philosophy: and its connection with political circumstances from the earliest times to the present*' London: Allen and Unwin, 1946.

Kaplan R B and Murdock L (1991) 'Rethinking the corporation: Core process redesign' *The Mckinsey Quarterly* 2 pp 27-43

Kay R and Bawden (1996) 'Learning to be systemic: some reflections from a learning organisation' *The learning organisation* 3 (5) pp 18 - 25

Keong Leong G and Ward P T (1995) 'The Six Ps of manufacturing strategy' *International Journal of Operations and Production Management* 15 (12) pp 32 - 45

Kim J and Arnold P (1996) 'Operationalising manufacturing strategy' *International Journal of Operations and Production Management* 16 (12) pp 45 - 73

Knott P, Pearson A and Taylor R (1996) 'Competencies in technology management: a new approach to competence analysis'

Kock Jr N F, McQueen R J, Corner J L (1997) 'The nature of data, information and knowledge exchanges in business processes: implications for process improvement and organisational learning' *The Learning Organisation* 4 (2) pp 70 - 80

Krafcik J F (1998) 'Triumph of the lean production system' *Sloan Management Review* Fall pp 41 - 51

Kreher H (1994) 'Some recurring themes in using soft systems methodology' *Journal of Operational Research Society* 45 (11) pp 1293 - 1303

L

Leonard-Barton D (1992) 'Core Capabilities and Core Rigidities: A Paradox in Managing New Product Development' *Strategic Management Journal*, Vol. 13, pp. 111-125

Leonard-Barton D, Kent-Bowen H, Clark B, Holloway C and Wheelwright S (1994) 'How to integrate work and deepen expertise' *Harvard Business Review* Sept. Oct pp 121 - 130

Lewis M and Gregory M J (1993) 'The development of a process approach to competence and capability analysis' EIASM Workshop on Strategy and competencies Brussels

Lewis P J (1992) 'Rich picture building in the soft systems methodology' *European Journal of Information Systems* 1 (5) pp 351-360

Long C and Vickers-Koch M (1996) 'Using core capabilities to create competitive advantage' *Organisational Dynamics* pp 7 - 21

M

Martin V, Whittle S, Tranfield D, Smith S, Childe S, and Maull R (1994) 'Strategies for regenerating manufacturing competitiveness - management by perception' *Proceedings of Factory 2000*

Maruchek A, Pannesi R, and Anderson C (1990) 'An exploratory study of the manufacturing strategy process in practice' *Journal of Operations Management* (9) 1 pp 101 - 123

Maull, R S, Weaver A M, Childe S J, Smart P A, Bennett J (1995) 'Current issues in business re-engineering' *International Journal of Operations and Production Management* (15) 11

Maure-Faure (1998) 'Self directed teams' Presentation at Sheffield moat house – workshop on teamworking

Menda R, Dilts D (1997) 'The manufacturing strategy formulation process: linking multifunctional viewpoints' *Journal of Operations Management* 15 pp 223 - 241

Meredith J R (1993) 'Theory Building through conceptual methods' *International Journal of Operations and Production Management*, (13) 5 pp 3 - 11

Meredith J R, Raturi A, Amoako-Gyampah K, Kaplan B (1989) 'Alternative research paradigms in operations', *Journal of Operations Management* (8) 4 pp 297-327

Miles M and Huberman A M (1994) *Qualitative Data Analysis: An expanded Sourcebook*, Sage

Miles M B (1979) 'Qualitative Data as an Attractive Nuisance: The Problem of Analysis', *Administrative Science Quarterly* (24) 4 pp 590-601

Miller J G and Roth A V (1994) 'A taxonomy of manufacturing strategies' *Management Sciences* 40 (3) 285-304

Miller D and Friesen P (1984) *Organisations a quantum view* Prentice Hall

Mills J (1995) 'Manufacturing strategy formulation' workbook

Mills J, Platts K and Gregory M (1995) 'A framework for the design of manufacturing strategy processes - A Contingency Approach' *International journal of operations and production management* (15) 4 pp 17-49

Minor III E D, Hensley R L and Robley - Wood Jnr D (1994) 'A review of empirical manufacturing strategy studies' *International Journal of Operations and Production Management* (14) 1 pp 5-25

Mintzberg H (1978) 'Patterns in Strategy formation' *Management Science* (24) 9 pp 934-48

Mintzberg H and Waters J A (1985) 'Of strategies, deliberate and emergent' *Strategic Management Journal* Vol. 6 pp 257-72

Morita M and Flynn E J (1997) 'The linkage among management systems, practices and behaviour in successful manufacturing strategy' *International Journal of Operations and Production Management* 17 (10) pp 967-993

N

Neely A, Mills J, Platts K, Gregory M and Richards H (1994) 'Realising strategy through measurement' *International Journal of Operations and Production Management* 14 (3) pp 140 - 152

Neely A. (1993) 'Production/Operations Management: Research Process and content during the 1980s', *International Journal of Operations and Production Management* (13) 1 pp. 5-18

New C (1986) *UK Manufacturing: The challenge of transformation* Cranfield School of Management Bedford

New C (1992) 'World class manufacturing versus strategic trade offs' *International Journal of Operations and Production Management* (12) 4 pp 19-31

Nonaka I (1991) 'The knowledge creating company' *Harvard Business Review* Nov-Dec

O

Ohno, Taiichi (1988) '*Toyota production system: beyond large-scale production*' Productivity Press

Ormerod Richard (1992) '*Combining hard and soft systems practice*' Warwick Business School Research Bureau, University of Warwick, (Warwick Business School research papers; 60). - x-70-268788-9

P

Pandya K V, Karlsson A, Sega S and Carrie A (1997) 'Towards the manufacturing enterprises of the future' *International Journal of Operations and Production Management* 17 (5) pp 502 – 521

Papin M W and Kleiner B H (1998) 'Effective strategic management in the aerospace industry' *Aircraft engineering and aerospace technology* 70 (1) pp 38 – 44

Parnaby (1979) 'Concept of a manufacturing system' *International Journal of Production Research* (17) 2 pp 123-135

Peters T J and Waterman R H I (1982) '*In search of excellence*' Harper and Row New York NY

Pickering I M and Chambers S (1991) 'Competitive Benchmarking: Progress and Future Developments', *Computer Integrated Manufacturing Systems*, (4) 2 May

Platt A and Warwick S (1995) 'Review of soft systems methodology' *Industrial Management and Data Systems* 95 (4) pp 19 - 21

Platts K W (1993) 'A process approach to researching manufacturing strategy' *International Journal of Operations and Production Management* (13) 8 pp 4-17

Platts K W (1994) 'Characteristics of methodologies for manufacturing strategy formulation' *Computer Integrated Manufacturing Systems* (7) 2 pp 93-9

Platts K W (1995) 'Integrated manufacturing: a strategic approach' *Integrated Manufacturing Systems* (6) 3

Platts K W and Gregory M J (1989) '*Competitive Manufacturing: a practical approach to the development of a manufacturing strategy*' IFS Publications: Bedford

Platts K W and Gregory M J (1990) 'Manufacturing audit in the process of strategy formulation' *International Journal of Operations and Production Management* (10) 9 pp 5-26

Platts K W, Gregory M J and Neely A D, (eds.)(1994) *Operations Strategy and Performance*, European Operations Management Association, Cambridge University

Platts K W, Mill J F, Neely A D, Gregory M J, and Richards A H (1996) 'Evaluating manufacturing strategy formulation processes' *International Journal of Production Economics* Dec 46-47 pp 233-240

Porter M E (1990) '*The competitive advantage of nations*' Free Press New York NY 1990

Prahalad C K and Hamel G (1990) 'The Core competence of the Corporation', *Harvard Business Review* Vol. 68, May-June, pp. 79-91

Prahalad C K and Hamel G (1994) '*Competing for the future: breakthrough strategies for seizing control of your industry and creating markets of tomorrow*' Harvard Business School press

Probert D R (1997) '*Developing a make or buy strategy for manufacturing business*' Institution of Electrical Engineers Manufacturing Series 1 ISBN 0 852 96 8639

Probert D R, Jones S W and Gregory M J (1993) 'The make or buy decision in the context of manufacturing strategy development' *Proceedings of the IMechE Part B Journal of Engineering Manufacturing* No 207 pp 241-50

Q

Quinn, Mintzberg, and James (1988) '*The strategy process. Concepts Contexts and Cases*' Prentice Hall International Editions

R

Ranger R (1997) '*Global Defence Review*' <http://www.global-defence-deview.com/DefenceTrends.html>

Rhodes D J (1985) 'Root definitions and reality in manufacturing systems' *Journal of Applied Systems Analysis* (12)

Riis J O (1992) 'Integration and manufacturing strategy' *Computers in Industry* Vol. 19 pp 37-50 COM

Roe G (1997) '*Strategic issues facing the aerospace industry*' Presentation of aerospace market and background BAe

Roest P (1997) 'The golden rules for implementing the balanced business scorecard' *Information Management and Computer Security* pp 163 - 165

Rummler and Brache (1990) '*Improving Performance How to Manage the White Space on the Organisation Chart*'

Russell B (1946) '*History of western philosophy: and its connection with political circumstances from the earliest times to the present*' London: Allen and Unwin

S

SBAC (1996) Competitive challenge pack

SBAC (1998) 'The competitiveness challenge: Report summary - People Management Report Summary', June <http://www.sbac.co.uk/industry.asp>

SBAC (1998) '*The competitiveness challenge newsletter issue 1*'

SBAC (1998) '*UK Aerospace industry statistics*' Newsroom industry information <http://www.sbac.co.uk/infeb98.htm> Feb

Schonberger R J (1982) '*Japanese Manufacturing Techniques Nine hidden lessons in simplicity*' Free Press New York NY

Schonberger R J (1986) '*World Class Manufacturing: the lessons of simplicity applied*' Free Press New York NY ISBN 0-02-929270-0

Schonberger R J (1987) 'Frugal manufacturing' *Harvard Business Review* Sept – Oct pp 95 - 100

Schonberger R J (1996) '*World Class Manufacturing: the next decade: building power, strength and value*' Free Press New York NY ISBN 0-684-82303-9

Schonberger R J and Knod Jr E.M. (1988) '*Operations Management: serving the customer*' 3rd Ed. Business Publications: Plano, Texas

Schroeder R G, Anderson J C and Cleveland G (1986) 'The content of manufacturing strategy' *Journal of Operations Management* (6) 4 pp 405-15

Schroeder R G, Anderson J C and Cleveland G (1991) 'The process of manufacturing strategy: some empirical observations and conclusions' *International Journal of Operations and Production Management* (11) 3 p 86-110

SCRIA Newsletter (1997) Vol. 1, Issue 1 Jan <http://www.sbac.co.uk/news/scria-nl.html>

Senge P M (1990) 'The leaders new work: building learning organisations' *Sloan Management Review* (32) 1 pp 7-23

Senge P M (1990) *The Fifth Discipline - the art and practice of the learning organisation* NY Double day currency

Senge P M (1994) '*The fifth discipline fieldbook: strategies and tools for building a learning organisation*' Brealey publishing

Sheridan J S (1993) 'Agile manufacturing: stepping beyond lean production' *Industry Week* April

Skinner W (1969) 'Manufacturing - missing link in corporate strategy' *Harvard Business Review* May-June 52 (3) 136 - 145

Skinner W (1971) 'The anachronistic factory' *Harvard Business Review* Jan-Feb

Skinner W (1974) 'The focussed factory' *Harvard Business Review* vol. 52, May/June pp 113-121

Skinner W (1978) '*Manufacturing in the Corporate strategy*' Wiley New York NY

Skinner W (1985) *'Manufacturing: the formidable competitive weapon'* John Wiley and Sons New York ISBN 0 471 817 392

Slack N (1990) 'Strategic Flexibility' Voss C A (Ed) *Manufacturing Strategy - Theory and Practice* Proceedings of the 5th International Conference of the Operations Management Association MCB Bradford

Slack N (1991) *'The Manufacturing Advantage – achieving competitive manufacturing operations'* Mercury Books: London

Slack N, Chambers S, Harland C, Harrison A. and Johnston R (1995) *'Operations Management'* Pitman publishing ISBN 0-273-60313-7

Smith A (1910) *'The wealth of nations'* introduction by William Letwin. Vol. 1 London: Dent. Originally published 1776. 0-460-00412-3

Smith D J (1997) 'Strategic alliances in the aerospace industry: a case of Europe emerging or converging?' *European Business Review* 97 (4) pp 171 – 178

Stalk G, Evans P, and Schulman L (1992) 'Competing on capabilities: the new rules of corporate strategy' *Harvard Business Review* March-April pp 57-69

Stobaugh R and Telesio P (1983) 'Match manufacturing policies and product strategy' *Harvard Business Review* March -April

Stokes P, Dubereley J, Tranfield D, Musson G, Smith S (1997) *'capability led manufacturing strategy and organisational routines: a case study approach'* working paper Sheffield Hallam University

Sweeney M (1993) 'Strategic Management: re-structuring wasteful production to world-class' *Journal of General Management* (18) 3 pp 57-76

Swink M and Harvey Hegarty W (1998) 'Core manufacturing capabilities and their links to product differentiation' *International Journal of Operations and Production Management* 18 (4) pp 374 - 396

Swink M and Way M H (1995) 'Manufacturing Strategy: Propositions, current research, renewed directions' *International Journal of Operations and Production Management* (15) 7 pp 4-26

T

Taylor F (1911) *'The principles of scientific management'* New York Harper

Teece D J, Pisano G and Schuen A. (1990) *'Firm Capabilities, Resources and the Concept of Strategy'* Working Paper No. 90-8, University of Berkeley: Berkeley, CA.

Teece D J, Pisano G and Shuen A (1997) 'Dynamic capabilities and strategic management' *Strategic management journal* Aug (18) 7

Thomas K W and Tymon W G (1982) 'Necessary properties of relevant research: Lessons from recent criticisms of organisational sciences' *Academy of Management Review* (7) 3

Tranfield D and Smith S (1998) 'The strategic regeneration of manufacturing by changing routines' *International Journal of Operations and Production Management* pp 114-129

V

Van de Ven A H (1992) 'Suggestions for studying strategy process: a research note' *Strategic Management Journal* Vol. 13 pp 169-88

Vickery S K (1991) 'A theory of production competence revisited' *Decision Sciences* Vol. 22 pp 634 - 43

Voss C A (1984) 'Production and Operations Management: A key discipline and area for research' *Omega, International Journal of Management Science* (12) 3 pp 309-19

Voss C A (1989) 'Strategic approaches to manufacturing' *The International Management Development Review* Brussels management Centre Europe pp 332-4

Voss C A (1992) (Editor) '*Manufacturing Strategy Process and content*' Chapman and Hall

Voss C A (1995) 'Alternative paradigms for manufacturing strategy' *International Journal of Operations and Production Management* (15) 4 pp 5 - 16

Voss C A. (1995) 'Operations management - from Taylor to Toyota - and Beyond?' *British Journal of Management*, Vol.6, Special Issue, S17-S29, December

W

Wainwright C E R and Bateman N (1997) 'Auditing system flexibility in the context of manufacturing strategy information' *Logistics Information Management* 10 (4) pp 167 - 177

Ward P, Bickford D and Leong K (1996) 'Configurations of manufacturing strategy, business, environment and structure' *Journal of Management* 22 (4) 597-626

Watson G (1992) '*The Benchmarking Workbook: adapting best practices for performance improvement*' Productivity Press: Cambridge, MA

Weaver A M (1995) '*A model based approach to the design and implementation of computer aided production management systems*' PhD thesis University of Plymouth

Weaver A M, Maull R S, Childe S J, and Bennett J (1994) 'A soft systems perspective of Business Process Re-engineering' Tenth International Conference on Systems Engineering *ICSE 94*, Coventry University 6-8 September, pp 1368-1375

Westbrook R (1995) 'Action research: a new paradigm for research in production and operations management' *International Journal of Operations and Production Management* 15 (12) p 6 - 20

Wheelwright S C and Clark (1992) 'Competing through development capability in a manufacturing based organisation' *Business Horizons* July - August

Wheelwright S C and Hayes R H (1985) 'Competing through manufacturing' *Harvard Business Review* May-June

Whittle S, Smith S, Tranfield D, Maull R, Childe S, Martin S (1994) 'Regenerating competitive performance strategy of capability building? A thematic approach to the regeneration of manufacturing competitiveness. Paper presented to the *European Association First International Conference on Operations Strategy and Performance*, Churchill College, University of Cambridge June 27/29

Wilson B (1984) '*Systems concepts, methodologies and applications*' Wiley 0-471-90443-0

Womack J P, Jones D T and Roos D (1990), *The Machine that changed the world*, Maxwell Macmillan international

Y

Yin R K (1994) '*Case Study Research: Design and Methods*' Sage Publications London ISBN 0-8039-5663-0

Appendices

Appendix one – Initial case studies for Phase One

Phase 1 – Case A
Phase 1 – Case B
Phase 1 – Case C

Appendix Two – Case studies for Phase Two

Phase 2 - Case D
Phase 2 - Case E
Phase 2 - Case F
Phase 2 - Case G
Phase 2 - Case H
Phase 2 - Case I
Phase 2 - Case J

Appendix Three – Modified approach to the formulation of a manufacturing strategy in a Workbook format

Appendix Four – Approach development and validation

Case I– validation workshops and comments
Case M - validation workshops and comments
Case N - validation workshops and comments
Other validation comments

Publications

Greswell T, Childe S J, Maull R S, Bennett J, 1995, 'A Two fold approach to manufacturing improvement', *Proceedings of the Twelfth Conference of the Irish Manufacturing Committee*, 6-8th September, University College Cork, pp. 429-436 (IMC95.ps)

Greswell T, Childe S J, Maull R S, Bennett J, 1995, 'Linking Manufacturing Strategy to process improvement', *Advances in Manufacturing Technology IX, Proceedings of the 11th National Conference on Manufacturing Research* 12-14 September, De Montfort University Leicester, pp 656-60 (NCMR95.ps)

Greswell T, Childe S J, Maull R S, Bennett J, Campbell N, 1995, The role of manufacturing strategy within a Business Process Re-engineering change programme, *Proceedings of the 13th International Conference on Production Research*, Jerusalem, Israel August 6-10, pp 144-146 (ICPR95.ps)

Greswell T, Childe S J, Maull R S, Bennett J, (1996) 'The linking of Manufacturing Strategy to Business Process Re-engineering' *Euroma Conference Proceedings* June 1996 London

Greswell T, Maull R, Childe S, Nash Z (1998) 'A soft systems approach to the formulation of a manufacturing strategy' European Operations Management Association Conference Proceedings Dublin 14 – 17th June 1998

Greswell T, Childe S, Maull R (1998) 'Three Manufacturing Strategy Archetypes - A Framework for the UK Aerospace Industry' IFIP WG 5.7 Working conference 1998, 26 – 28 August, Marine Highland Hotel, Troon

Greswell T, Childe S, Maull R, Smart P (1998) 'The development of three manufacturing strategy-making systems' presented at MIM 98 University of Nottingham

Appendix One

Phase 1 – Case A
Phase 1 – Case B
Phase 1 – Case C

1.1. Case A

The collection of data has been carried out using a series of interviews, workshops, meetings, company documents and company videos over a 6 month period from October 1994 to April 1995.

1.1.1. Type of Case

Prime Contractor

1.1.2. Participants

Manufacturing Strategy Executive and Strategist

1.1.3. Source of data

Structured and unstructured interviews, 2 weeks spent at the organisation. Formal and informal meetings.

1.1.4. Validation

The transcripts of the interviews were sent to the manufacturing strategy executive and the manufacturing strategist for validation.

1.2. General Background

Case A as a whole has seen its markets completely change over the past decade, the arrival of the global market, the disintegration of the Soviet Bloc and the change in the procurement policy of its major customers. Case A used to operate in an environment of 'cost plus' contracting which ensured the company always made a percentage profit, the critical success factor in this climate was one of the quality of the final delivered product - at any cost. The climate has changed completely, Defence companies must now bid for work from their major customers at a fixed price, therefore affordability and quality have become the critical success factors in the current climate. Competition is becoming increasingly fierce as the British Government in particular has a policy of competitive tendering, not necessarily from British Firms. The pacific rim is increasing its capability in aerospace technology therefore the market is in a constant state of change.

Case A has had to change to survive and in a lot of cases the changes have been extremely painful but effective, whilst in other areas the pain is still to come. In the late 1980's the aerospace market changed dramatically due to the peace dividend. The manufacturing function was not well positioned to cope with the next 10 years and action was required to remedy the situation. The significant event which appears to be the trigger for the re-evaluation of manufacturing strategic role in the business was the cancellation of a large order. Analysis showed that change was a necessity. The manufacturing restructuring programme was based around this event.

The key factors which enabled the definition of the strategy were

- Sizing
- Charge rate
- Core Business's

The analysis which was carried out looked at the current build programmes and the required head count to carry out those programmes according to the charge and rate and the actual head count at that time. It emerged that Case A had excess capacity. It was decided that the most effective method of operation was to operate within a framework of 4 sites. 2 sites were designated final assembly sites and 2 sites were designated feeder sites. The 2 feeder sites would control their own 'food' chain and supply the assembly sites. Essentially the 2 feeder sites were in competition with each other.

A fishbone diagram was used to determine the core skills that were required at each site and to articulate the VISION which was formulated by a small dedicated team.

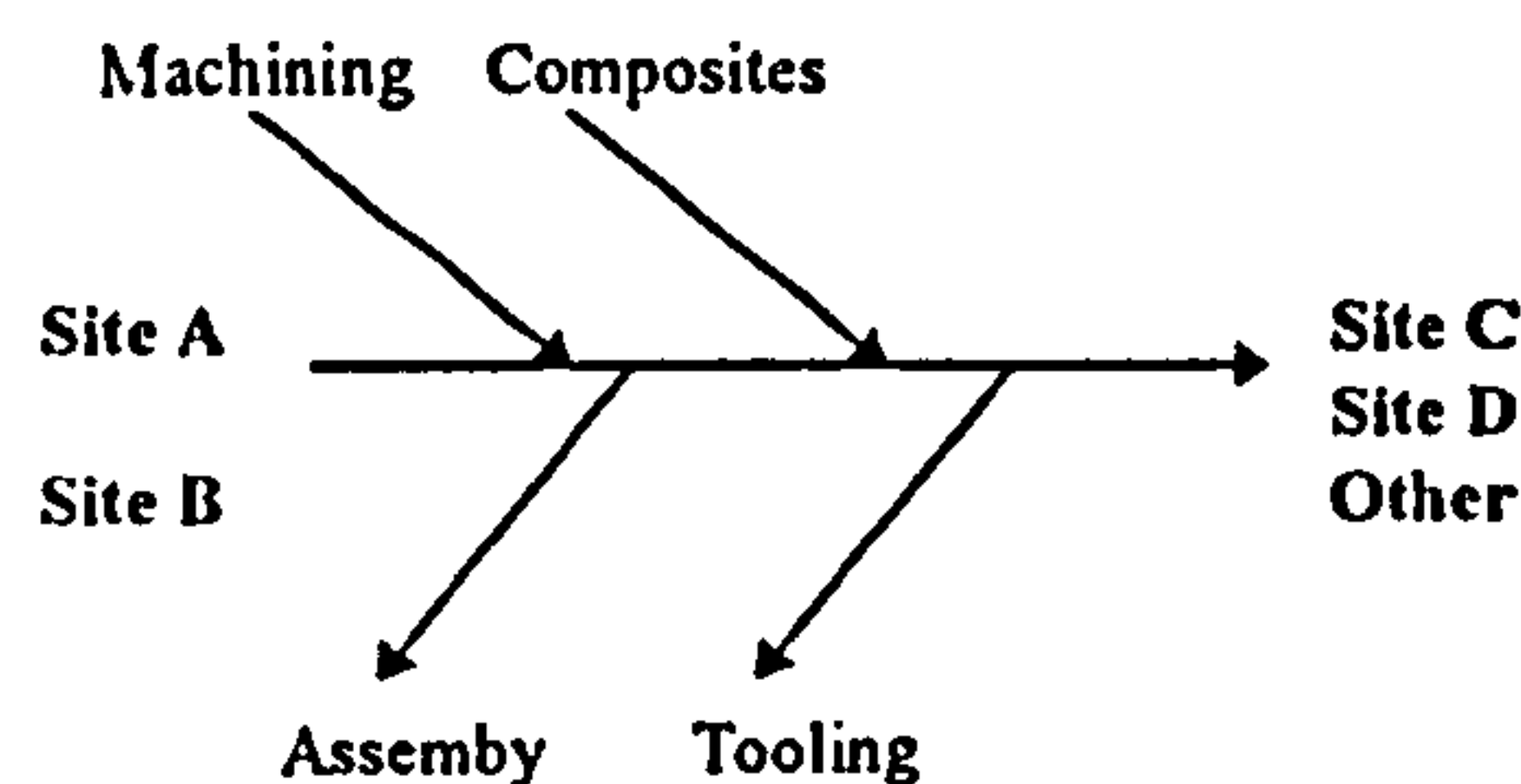

An analysis of the skills base was carried out within each of the sites. As the whole costing structure was based on man-hours, this was a main driver. It was decided that 2 sites would close with the main transfer of technologies to the feeder sites.

1.2.1. Position in Supply Chain

Prime Contractor, Systems Integrator and systems supplier.

1.3. Case A - The Manufacturing Organisation

The business planning process seeks to address objectives for 1 - 5 years. The process has sought to introduce team boards across projects and a team board culture. The aim of the business planning process is to ensure critical success factors and key performance indicators were linked from the business plan to personal objectives. The business plans are reviewed on a monthly basis.

The drivers are filtered through from corporate strategy. The main mechanism for this is the business plan which generally has a 5 year horizon. Key performance indicators and critical success factors are filtered through site, directorate and department level. The business plan then directs managers to provide employees with objectives linked to the key performance indicators and critical success factors. These objectives are in turn linked to the management of performance system - management by objectives. Within manufacturing a datum is established from the drivers which is used to bound the

goals of the manufacturing function. When the bounding activity is undertaken the knowledge and influence needed to achieve the goals is considered.

The manufacturing strategy formulation process is heavily influenced by the excessive rate of change of technology. In order to overcome the problems of long learning curves and the expertise and competence build up required, consultants are brought in. The consultants are used to provide a business focus for specific projects within the business. The consultants are invited in for a 5 day period in which the technology, processes and cost benefits are considered for any 'new' technology. A report is produced on the deliverables and resources required to ensure the successful implementation of the 'new' technology. A decision is usually made within 3 - 6 months of the report being submitted.

General issues concerned with manufacturing strategy

When discussing the issues around strategy, any major decisions such as the closure of sites etc. are financially driven. The financial drivers are based around the charge rate. When making other major decisions such as a capital case or new equipment. The major drivers are product complexity, process choice, contractual obligations and commercial obligations

1.4. Process of Manufacturing Strategy Formulation

1.4.1. General Strategy

1. Determine Critical Success Factors
2. Assess:
 - current political and economic climate
 - customer base
 - future projects, future technologies and future capabilities
3. Assess:
 - current capabilities
 - facilities
 - skill base
4. Determine gap between present and future
5. Formulate plan to achieve 'vision' of the future
6. Implement programmes - determine intervention tools
7. Monitor
8. Reassess according to changes in conditions

1.4.2. Point of Entry

The trigger for the main change programmes around Manufacturing have come from the cancellation of a main contract which originated from the peace dividend.

Time Line

- | | | |
|------------|--|---|
| Early 80's | Aircraft Group - Covered both Military and Civil
Dissolved Aircraft Group | <ul style="list-style-type: none">• Less formal strategy• Controlled investments on various manufacturing sites• Key Performance Measure - quality of the final product [tornado]• Drive to profit centres Each centre responsible for own profit• generated own business plan with the effect of allowing the formulation of functional strategies i.e. manufacturing |
| 1988 | | <ul style="list-style-type: none">• Strategy became a restructuring plan for the division due to changes in the market place• ?'s asked - what was important for manufacturing - driven by the vision of the future• multi project environment• new driver was affordability, flexibility and cost of quality• standard drivers - quality cost, schedule and capability• Main contributor to cost is CHANGE• Therefore the major driver of the strategy was to improve flexibility, minimise cost and improve schedule adherence• Technology - driven by future projects and future products• needs to be affordable and perform well• need to generate the technologies to produce performance at lower cost• Trade - offs - to drive capabilities to make future projects and improve processes |

1988 - plan to close a main site over the next decade

1 - had to remove capacity - not sustainable to work flow

2 - where is the optimum place to develop the capacity

old buildings, hopeless layout, city centre location, poor for flexibility

Long term - needed less capability

With the cancellation of a large order there was an immediate drop in workload therefore had to accelerate plans to close the site A [1992], took 3 years to get investment in place at site B. Closing site A gave a good climate for change - invested in site A, introduced Cellular manufacturing, PPP, flexible manufacturing. Would have been different if the closure of Preston had not happened. People recognised the need for change is more readily accepted due to the shock of going through the pain of the closures

Customer Support - made a lot of savings

Workload - forecast is a key input onto the manufacturing strategy and capacity requirements

MIDAS - used for forecasts 2,3,10 and 20 years

1.4.3. Participation

The 4 site directors, the manufacturing director, the logistics director and Gareth Hughes [Manufacturing Strategy Executive] meet periodically to discuss all strategic issues at this forum.

1.4.4. Project Management and Timescales

3 - short term - used for moving labour and work packages

5 - Business Planning timescale

10 - Much more useful

20 - looked at once a year

Business Planning process - objectives 1 - 5 years

Introduction of team boards and team board culture

improves performance metrics

Forecasts for the next 2, 3, 10 and 20 years are used. The 3 year forecast is used of the movement of personnel and the movement of work packages throughout the sites. The 5 year forecast is generally used for business planning. The 10 year forecast has been described as the most useful, The 20 year forecast is reviewed once a year.

1.4.5. Hayes and Wheelwright Four Stage Model

appears to be at stage 2.

1.4.6. Decision Areas

- Performance Measures - divisional measures are company wide. Sites do have different measures
- Introduced schedule adherence measures - found to be very reliable. Local measures - on team boards in the shops. Divisional measures are very visible. Introducing
- SPC in the office areas - e.g. Production engineering Brough. Measures are local area specific. SPC has been very good for awareness

Technology links

The link to the development of technologies and the manufacturing strategy formulation team, comes from the manufacturing executive being the manufacturing representative on the technology board. New technology is essentially imbedded in the development of new products.

The manufacturing function is to provide a cost effective, efficient and lean way of producing those products.

The 'BIG' processes such as Carbon Fibre Composites [CFC] and Super Plastic Forming and Diffusion Bonding [SPF DB] - are both material and process driven.

The manufacturing function also has an interface link with advanced projects to ensure involvement and developments of the appropriate technologies.

Facilities

Case A decide what is needed and Corporate usually agree
Capital investment approval - Case A approval > 1 million
Division approval > 10 million

Development of Core Competencies

The development of core competencies is interlinked with the technology strategy and the capital cases board to allow the development of manufacturing facilities and technology. A strategic investment plan is developed in association with manufacturing research and development.

Technologies Development

- always looking at priorities
- looking at new projects
- development of technology in other markets
- need emphasis of long term capability development with short term payoff.

Consistently look at what areas of manufacturing are involved in and whether we should have these technologies

Manufacturing technologies and philosophies

- Lean Manufacturing route - WIP reduction
- Minimise lead times - managed to halve the Eurofighter Lead-time
- JIT

Management of Technology

- Manage technology as a project with representatives from functions - cant look at manufacturing technology in isolation.
- Key technologies
- Carbon Fibre Composites - product driven - Centre of excellence for composites
- High speed machine tools - Jomachs
- SPFDB - Super plastic and Diffusion Bonding - efficiency driven
- Mechanical assembly - flexibility based
- [major investments]
- Assembly - mechanical assembly in 4 shed

- High tolerances - interchangeability
- Assemble to much higher with less product specific tooling
- Flexibility -- cost of change
- Investment in CATIA

1.4.7. Make or Buy Philosophy

Looking at the classical manufacturing decision areas. The make or buy decisions within manufacturing are immense. Around 80% of items are bought out items, sub contracted items.

1.4.8. Emergent or Planned - the Process

Tends to be emergent.

1.5. Change Programmes resulting from the Manufacturing Strategy

Initiatives to support Manufacturing Strategy

O.E.I. - Operational Improvements Initiative: Looking at influencing manufacturing and improving how we do today on cost and schedule with a big emphasis on training

Areas involved: Manufacturing Technology Customer Support Purchasing

Aim is to develop specific capabilities and improve the efficiency of factory operations

Current initiatives under the OEI banner

- ☎ Engineering computers [design]
- ☎ Operational computers
- ☎ Sub contract - supplier relationships, preferred supplier scheme
- ☎ Logistics - LASER - manufacturing and transport
- ☎ People - investors in people - manufacturing
- ☎ BPR - Sept. 94 OPS 1 - Process from C Schemes to concept drawing to tool design
- ☎ OPS2 - Advances studies to C Schemes
- ☎ OPS3 Tools available to manufacturing of first batch

Cross functional across operations

OPS 1 - spur of other BPR activities

BOM - all functional appeared to have different Bills of Materials

Qualification of the product - QA, Cleaning structure and systems , CAA approval

Technologies Development

- always looking at priorities
- looking at new projects
- development of technology in other markets
- need emphasis of long term capability development with short term payoff.

Divisional research side - manufacturing technology is driven by the product technology
Weighting exercise - usually subjective - where to invest time and money

Consistently look at what areas of manufacturing are involved in and whether we should have these technologies

Manufacturing technologies and philosophies used at Case A

Lean Manufacturing route - WIP reduction
Minimise lead times - managed to halve the Eurofighter Lead-time
JIT

Problem that partners are not doing that
Different organisations have different drivers
Partnerships do complicate things - collaboration

Management of Technology

Manage technology as a project with representatives from functions - cant look at manufacturing technology in isolation.

Business Process Re-engineering

BPR has not affected the manufacturing strategy process or content as yet. Altering the As Is process's have not really affected the strategy.

Initiatives to support Manufacturing Strategy

OEI - Operational Improvements Initiative

A major initiative has been initiated to help Case A in its drive towards the future. The Operational Improvements initiative has a 5 year vision to achieve a 50% reduction in elapsed times, a reduction in the costs of operations by 30% and a 100% adherence to schedule, cost and specification. A document has been produced to provide a vision and a framework from which the strategy and investment plans can be produced. Engineering computing has been identified as one of the key enablers to achieve the 5 year vision. EC has been defined as '*the application of computer technology to all engineering related work from conceptual design through to the delivery and support of the product together with the process data enabling effective manufacturing operations to commence, it covers all the non-recurring aspects of the delivery of the product, information for manufacturing and other downstream processes*'.

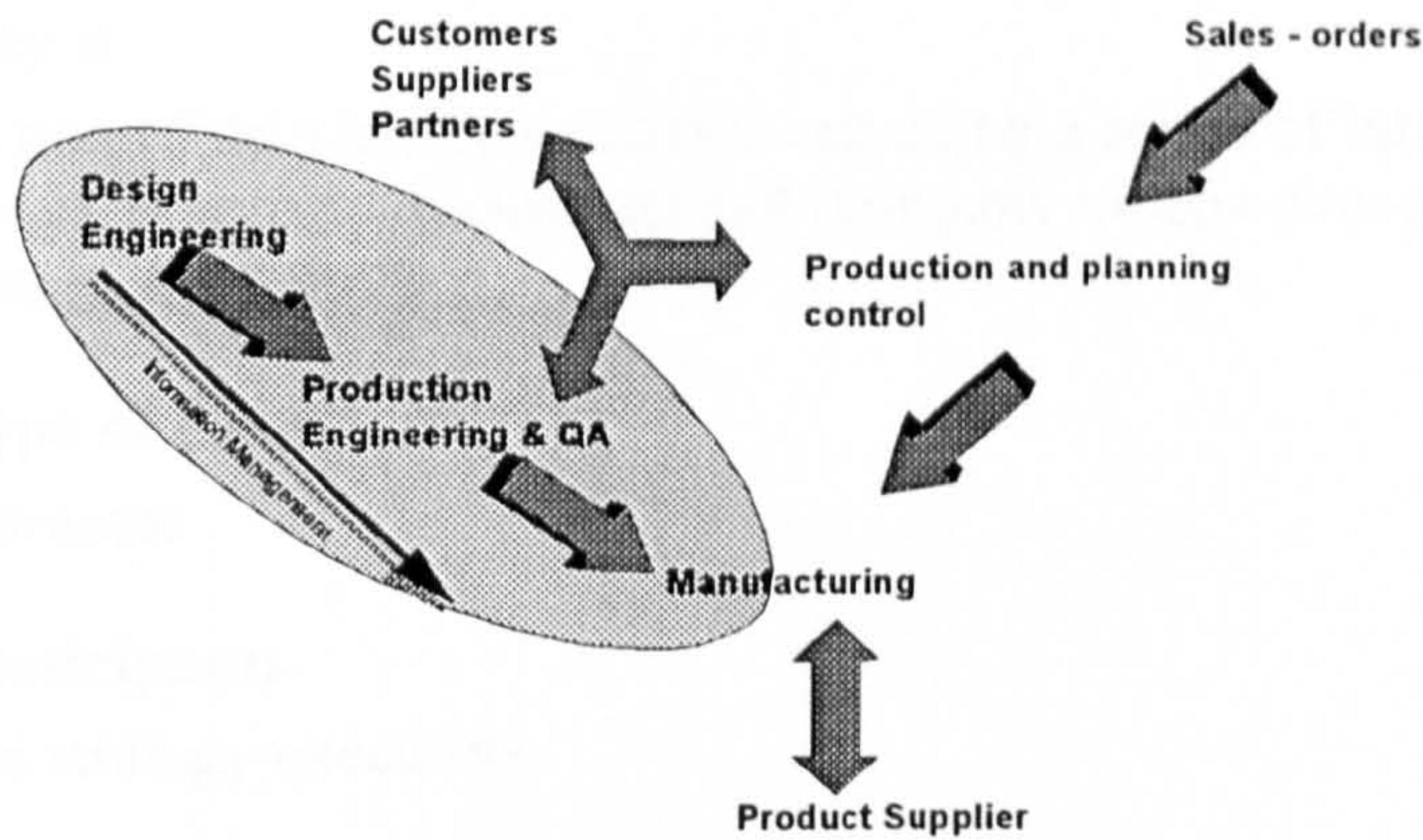

Technologies development - due to the nature of the product and customers, technology development is always a high priority. Priorities are always being looked at, as are new products and the development of technology in other markets. An emphasis appears to be made on long term capability development with short term payoff - whether this works or not may need further clarification. Investment is heavy in the aerospace industry so the decision to go for one technology as opposed to another can not be taken lightly.

Manufacturing technology tends to be driven by product technology. The requirement for lighter material, stealth and high agility aircraft have transferred to manufacturing with the development of techniques for carbon fibre composite, smart skins and so on. The weighting exercise that occurs has been described as mostly subjective as to where the money and time is spent. It can possibly be assumed that personalities and the ability to play the system have an astounding part to play in the emerging technologies and capabilities within manufacturing.

Following on from the 5 year vision, Case A appears to have taken the world class manufacturing model - lean manufacturing route. Focusing on Work In Progress reductions, minimising lead time and Just in Time philosophies. On a side note, one of the major problems Case A may have in achieving its vision is the problem of collaborative projects. Different organisations have different drivers, if the partners are not moving in a similar direction with their manufacturing systems, it will be harder to co-ordinate in the long term. Partnerships can be taken to complicate matters somewhat.

1.6. Technology is managed as a project within Case A, with representatives from the various functions involved. Manufacturing technology can and is not viewed in isolation.

1.1. Case Study B

The collection of data has been carried out using a series of interviews, workshops, meetings, company documents and company videos over a 6 month period from October 1994 to April 1995.

1.1.1. Type of Case

Prime contractor

1.1.2. Participants

Production strategy executive

1.1.3. Source of data

Empirical research was deemed the most suitable method. In-depth interviews were held with The Engineering Strategy Executive.

1.1.4. Validation

The transcript was validated by the engineering strategy executive.

1.2. General Background

Company B was restructured 8 weeks before the writing of this initial case study. The company is predominantly in the commercial aerospace market and is a supplier of various parts of airframes to the majority of the world market. The merged organisation has a projected turnover of 220 million.

A pictorial view of the relationship of the newly formed company to the rest of the parent division is shown below.

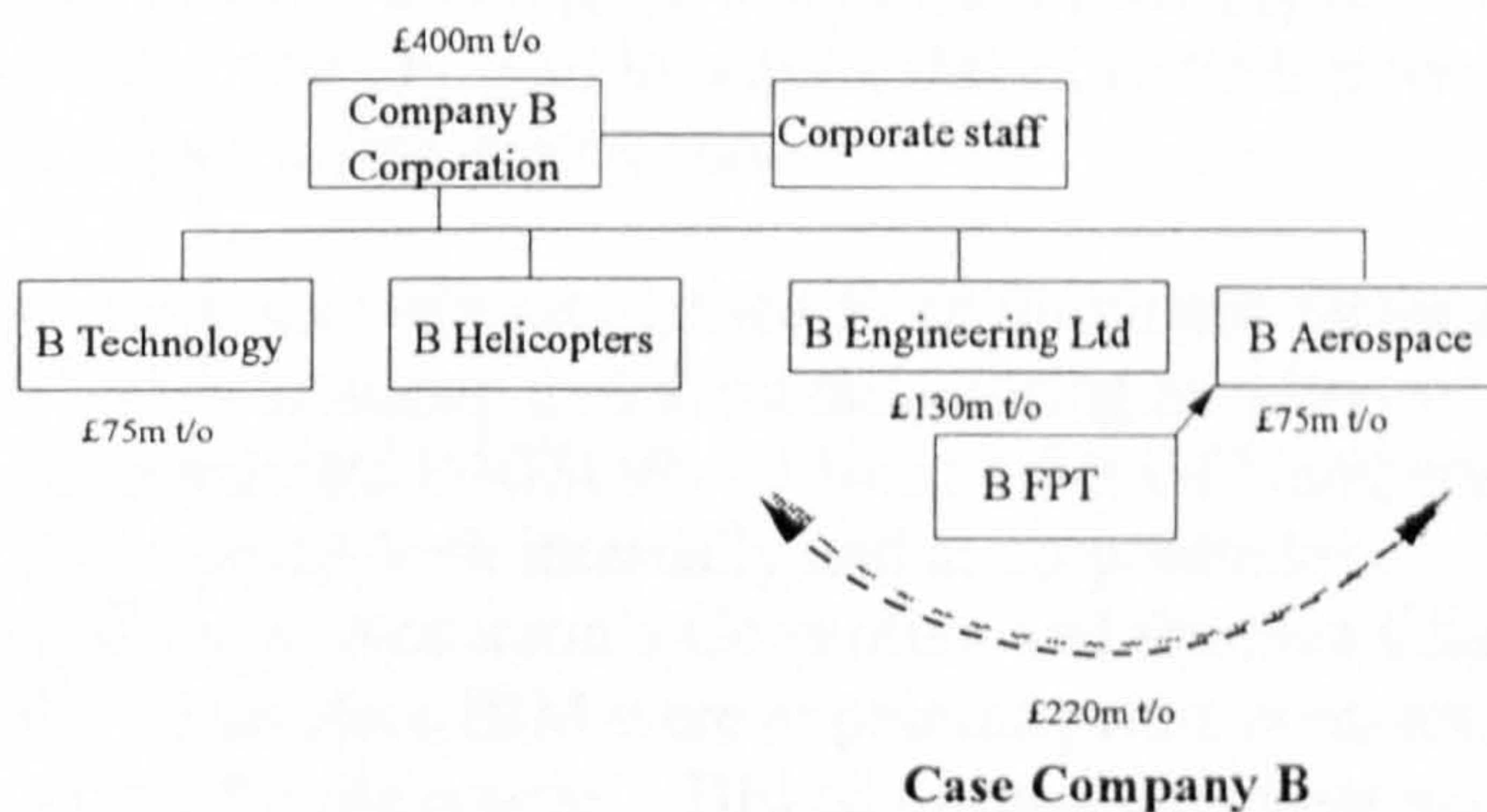

At the present time (1996) there is considerable pressure to reduce costs within the organisation. The original organisation saw the reduction in employees from 2600 to 1200 whilst simultaneously increasing turnover. The present organisation has been tasked with doubling in size over the next 5 years.

This could be done in a variety of ways - discontinuous and continuous improvement. Opening up new business areas which will allow the organisation to bid to enter other markets. There are several options to allow the organisation to grow

1. extend up the value chain
2. develop core competencies in other areas

but must always remember the core competencies of the business.

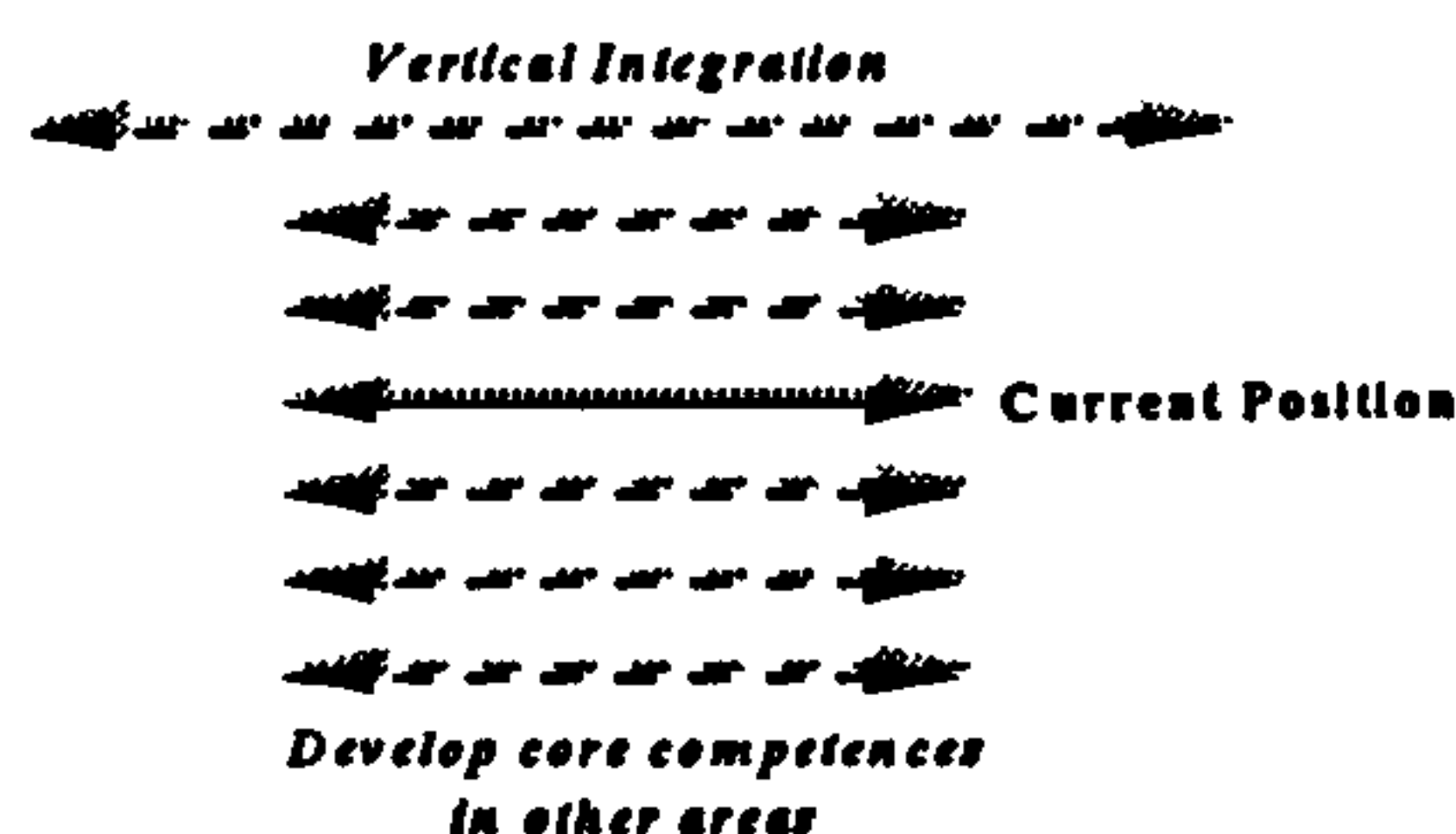

1.3. Case B - The Manufacturing Organisation

Over the last four years the parent company has experienced a few problems with the changing business environment and the technologies used for its core products.

When the B Engineering section was disengaged from the helicopters division, an initiative was started which predates Hammer's paper 'Re-engineering work: Don't Automate, Obliterate' and has all the hallmarks of business process re-engineering. Before then, manufacturing had been seen as the 'poor relation' so there was a huge sigh of relief. The engineering organisation was set up to be able to supply both the helicopters division and other companies. Likewise the helicopter division was able to obtain assemblies and sub assemblies from both the engineering division and others. This was planned to ensure that the engineering organisation was well placed to become a lean competitive organisation - it had to be otherwise the helicopter division would go elsewhere. The separation was physical in nature, therefore BELtd needed systems of their own and an organisation that would match.

At this stage processes were recognised as an important factor as was the need to adopt the ideas involved in attaining global manufacturing excellence. A concept was developed which was christened UNISON - U Need 1 Set Of Numbers. The concept generated considerable interest both internally and at corporate level. The Helicopters division had strong links with Anderson's Consulting and the then Chief Executive had strong links with IBM. Therefore IBM were appointed prime contractors and Anderson's were appointed as 'clerks for the course'. BELtd formed their own team which in retrospect was seen to be too lightweight. The team consisted of the whole of the IS department - 5 people. [The remaining 150 stayed at the BHLtd]. It was explained that Anderson's sent in their 'B' team for the project - due to their relationship with the CEO they apparently always expected to get further work.

The project was estimated to be worth £6 million. The internal team provided IBM with the functional specification. The plan was to discontinue all the small systems that had been set up and replace them with an 'all singing all dancing' system which

included networked relational databases, client servers etc. It was estimated that it would take 18 months to complete.

Problems occurred with the hand over - the two systems were run in parallel for a while. When UNISON was booted up it fell over. 40 Programmers were drafted on to the site for 3 months to solve the problem, when UNISON was booted up it fell over again.

It became clear that IBM were using the organisation to develop their own product, they were committed to their own hardware when other products on the market which were already available would have been suitable. The words used to describe the project were 'at a level of ambition that they didn't realise'. A series of watershed meetings were held between BELtd and IBM to solve the problems caused. Anderson's had been dismissed by this stage as it became clear that they were not performing their function as required. Following the water shed meetings it emerged that the planned system would never work. IBM were successfully sued for the cost of the project.

The internal IS team of 5 had received an extensive education following the episode and implemented a 'really good' network. Consisting of an excellent PC network together with stand alone systems. A new project was initiated to try and salvage what they could from UNISON. The new project was affectionately know as BISON.

The organisation learned a lot from the episode, about their company and its processes, the need to understand the organisation and the need to project manage. The need for a coherent strategy for the organisation to be able to focus on what changes were necessary was found to be important..

The case study will be developed over the remaining research period. This is an ideal case to test out ideas and concepts as the organisation.

1.3.1.1. Point of entry

The point of entry can be defined as the point when the organisation recognised the need to re-address the role and strategy of the manufacturing function. The history of the newly formed organisation stretches back to the time when part of the new organisation was a hovercraft manufacturer [1990]. When the 'cross channel' market changed considerably the organisation realised that it did not have a viable product or a viable business BUT they did have an excellent manufacturing capability.

The technology used in the development and manufacture of hovercraft was/is closely related to aerospace technology. The hovercraft were essentially being built as aircraft. The company looked at the design and manufacturing of boats to reduce the overall costs of the craft. Despite being successful in reducing the cost, other technologies were still surpassing it. The order winning criteria for the hovercraft was that it could go over both land and water. They decided however that the market was not going to sustain their business.

The strength of the business lay with its manufacturing capability, composite expertise and cost reduction capability. The organisation has not progressed any further and the thinking on manufacturing strategy has reached a plateau. It is understood that they need to produce an excellent manufacturing organisation, are currently at the leading edge of manufacturing competence, and understand the need to ensure that their competitors can not close the gap. The Engineering Strategy Executive has a clear understanding of the issues involved and a clear direction planned.

1.3.2. Participation

Participation can be defined as the key areas and people involved in the development of the manufacturing strategy. The employees in the newly formed organisation do talk to each other, and issues are not resolved in isolation.

1.3.3. Project Management and Timescales

There is at this time no formal process for the formulation of a manufacturing strategy. Therefore the strategy that exists has emerged as opposed to being planned using any particular architecture. Project management at this moment in time was described as 'pot shot'.

The planned methodology encompasses a top down approach which will initially define the strategic architecture i.e. - what is the organisation going to do. This will then be cascaded through the organisation using the Quality Continuous improvement [QCI] mechanisms which already exist. I.e. linking the strategy formulation process with innovation.

It is proposed to use a competence matrix to identify core competencies and identify how the organisation scores with these core competencies.

A 'wish list' is being developed to determine where the organisation would like to be concerning their core technologies and skills. The 'wish list' falls into two categories - process improvement and process re-engineering. .

The link between business and manufacturing strategy must be closely linked, to do this the core competencies need to be understood in order to extend them and build them. It is important to look at the customers needs and determine what the organisation must do in order to fulfil their requirements, this may necessitate the procuring of other businesses.

NB - Sikorgsky have a list of their best and worst suppliers on a board in their entrance hall at their headquarters. This really focuses the suppliers minds if they are on the 'bad' list.

1.3.4. Hayes and Wheelwright Four Stage Model

The company is described as being between stages 3 and 4.

1.3.5. Emergent or Planned - the Process

The process is emergent at present

1.4. Change Programmes resulting from the Manufacturing Strategy

BPR at Corporation B - B Helicopters have not approached the area as yet. B Engineering and B Aerospace - Now merged - initiated a BPR programme 15 months previously. The Information Systems Department already believed they were doing it, purely from a systems point of view. The IS department were using the concept to justify potential systems for example Product Data Management. A meeting of minds occurred between the managing director and the IS department. The background to the approach used for improvement was for 6 years the organisation had a very good quality improvement plan, having gone the Crosby route. There was a large commitment to training, workers groups reward systems and prizes. In terms of the Maull Framework the organisation has gone along the process improvement route.

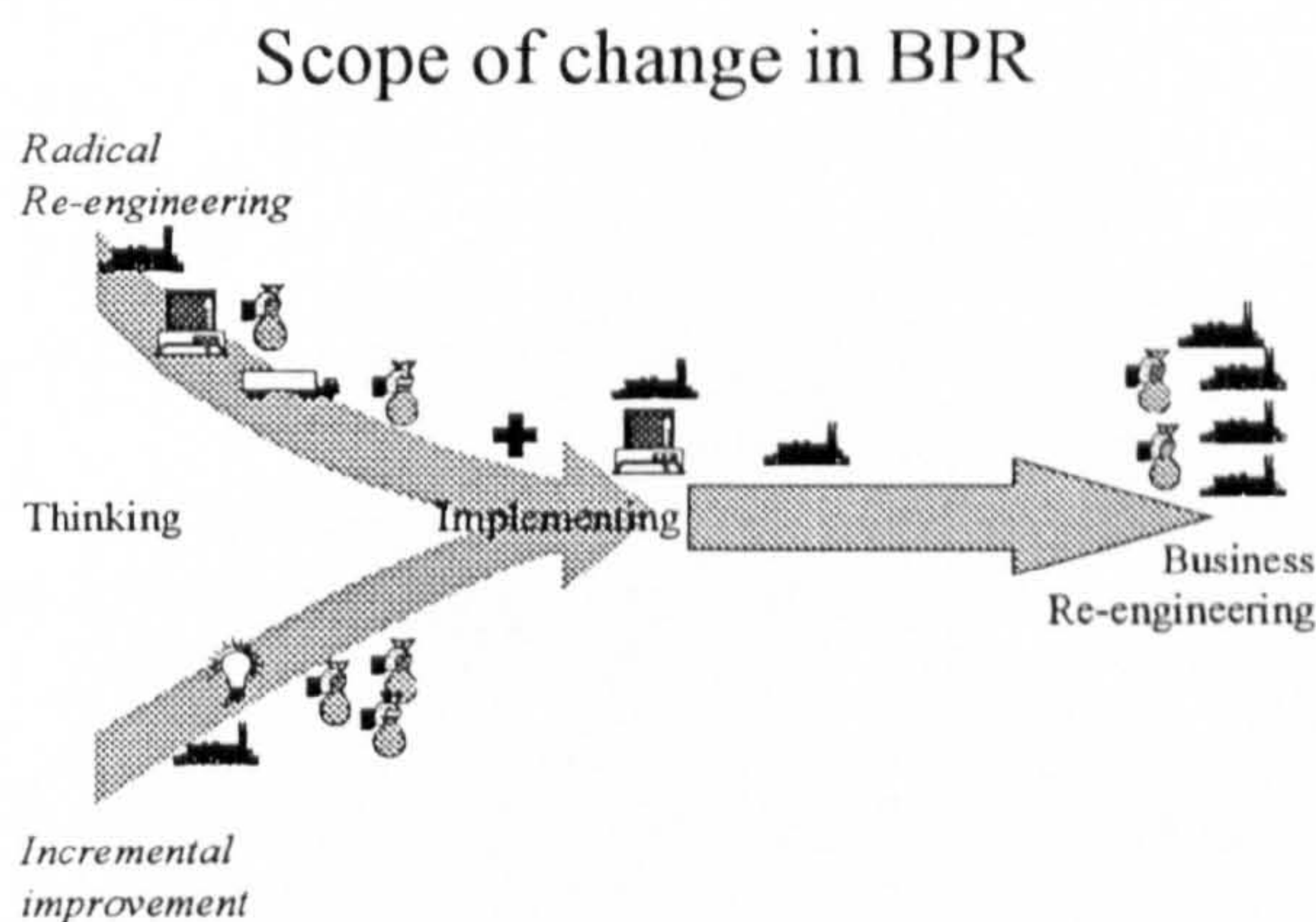

Senior management teams have been tasked with looking at the following processes

- Get Business
- Logistics
- Repeat Manufacturing
- Enquiry through to first article

At the moment no one really understands what Business Process Re-engineering is all about - what has been done up to now has been described as Value Engineering.

The future plans are to bring in Quality Continuous Improvement and the BPR programme simultaneously. Cross functional integration is accepted as being key.

At the moment BPR is being bounded around by 'everyone' - however it is the general feeling that not many people really understand what it is all about. People are concentrating on processes and working well together. At the moment there is no process modelling, no process hierarchy. However the work procedures are all documented in the company operating manual, the company has preferred supplier status from Boeing and McDonnell Douglas

1.5. Emergent Manufacturing Strategy Archetypes
Knowledge based and world class manufacturing

1.1. Case Study C

The collection of data has been carried out using a series of interviews, workshops and meetings over a period from October 1994 to June 1995.

1.1.1. Type of Case

Systems and Component Supplier

1.1.2. Participants

Manufacturing Director
Chief Engineer
Research and Development Manager
Manufacturing team Leaders
Purchasing & Supply Director
Graduate Engineer

1.1.3. Source of data

Interviews, Workshops, Company Meetings, Company Documents, Validation

The data gathered over the period has been continually validated and updated through a close working relationship with the organisation.

1.2. General Company Background - Organisational Structure

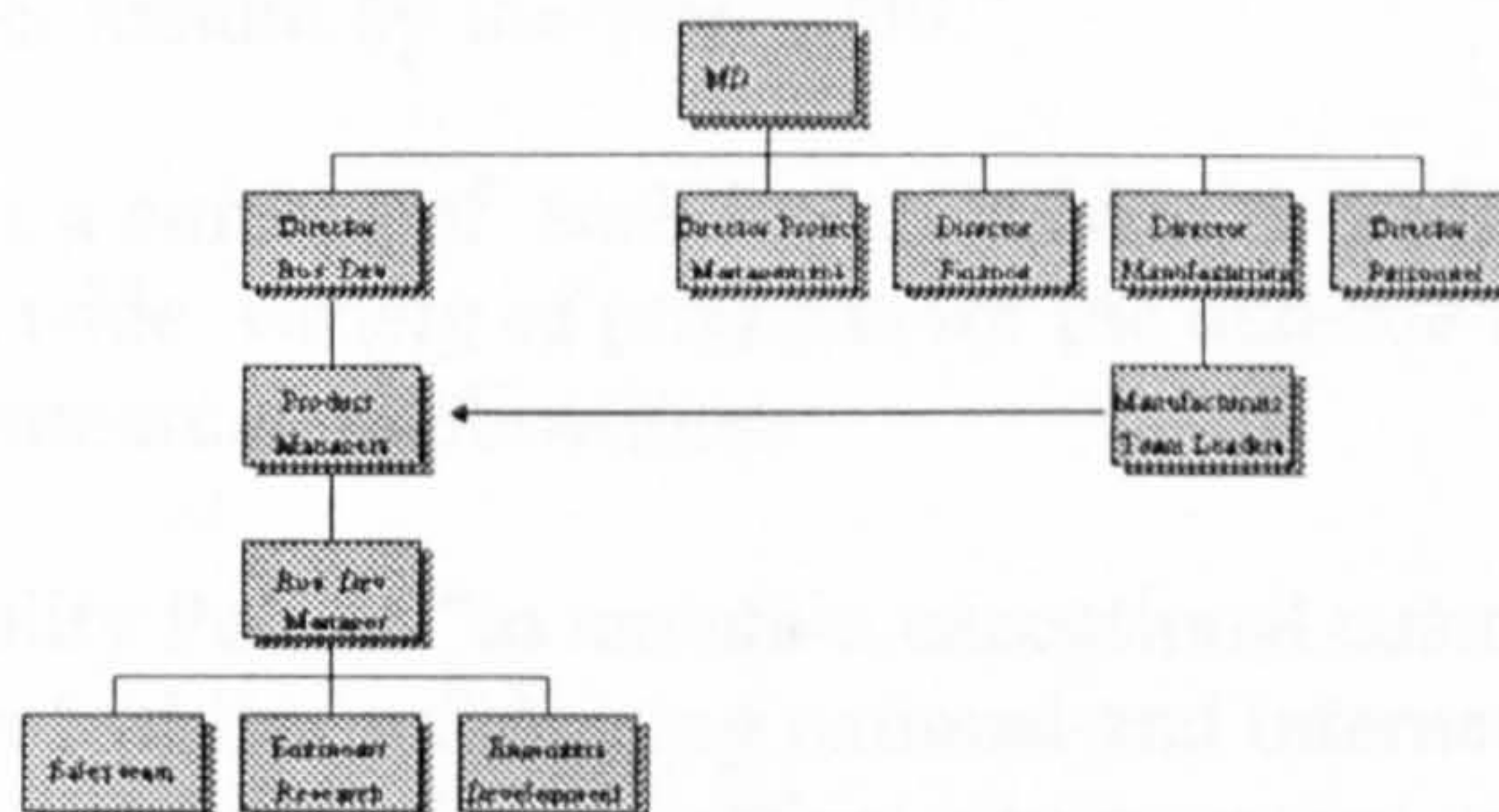

Previously to 1995, the organisation consisted of two distinct groupings, however this situation is now changing and the business is heading in a unified direction. The organisation is currently aligning around business processes as opposed to products. Resource managers have been allocated to take the wider view [this may be a difficult role].

The Product Management role appears to be becoming redundant - Case C is moving towards a business process focus although no general definition of a process has yet been defined. Project Management is one of the key skills required in the new organisation. However several key processes have been identified.

Key Processes

- Finance
- Personnel
- Resource Management
- Manufacturing
- Business Development
- Engineering

Business Development is the dominant process [view of sales and marketing]. Winning customers and orders comes first.

Case C is a European leader in high technology aerospace and defence engineering, specialising in Motion Sensing, Avionics, Reinforced and Microwave Plastics, Electro-Optical Systems and Information Systems. Case C has seen its markets completely change over the past decade. The arrival of the global market, the disintegration of the Soviet Bloc and the change in the procurement policy of its major customers has been a major contributor to this change. Case C was used to operating in an environment of 'cost plus' contracting which ensured the company always made a percentage profit. The critical success factor in this climate was one of the quality of the final delivered product - at any cost. The climate has changed completely. Defence companies must now bid for work from their major customers at a fixed price, therefore affordability and quality have now become the critical success factors.

Current turnover is 65 million per annum. The aim of the company is to achieve 100 million turnover per annum by the year 2000.

Case C employs a number of enabling technologies which give it the expertise to develop and produce a wide variety of products for the defence industry and an increasing range of commercial applications.

Company's Quality Policy: "to maintain exceptional customer satisfaction through continuous improvement whilst maintaining national and international Quality System Standards Approvals." Customer focus, product improvement, process management, staff competence and empowerment all feature strongly in a business improvement strategy that uses self assessment against the European Foundation for Quality Management Business Excellence Model as a primary driver.

Case C is committed to international partnerships to complement its product portfolio and develop new technologies and products. Partnerships are already in place with a number of companies on several projects in defence and civil markets as follows:

1.2.1. Position in Supply Chain

Case C can be described as a Systems and Components Supplier within the UK aerospace supply chain and also in international markets.

1.3. Case C Manufacturing Organisation

Case C are in the business of supplying gyros and inertial products primarily to the aerospace and the defence sector. Although the commercial market is growing. Sell to Original Equipment Manufacturers [OEMs].

When securing an order it is important to look professional and be committed to the business. 60 - 70 percent of potential customers come to look at the factory before they place an order.

Case C do not provide a service, their business is to develop and sell products which are expected to work i.e. do not require after sales service.

Investment

Lots of investment in new technologies

Make up of individual cells

Each cell has between 3 - 12 employees, these consist of assemblers who are either skilled or semi skilled, Inspectors and Testers. Movement between trades is encouraged. Cells are more or less autonomous, with little material movement between cells. Most cells take the product completely through the process, through to dispatch.

Support Groups [central resource]

There are several cells set up as a central resource, these include: Calibration, Test Equipment Maintenance, Goods inwards, Stores, Maintenance: Planned maintenance for large pieces of kit, planned service schedule and emergency maintenance, Chemistry lab

Manufacturing System Set Up

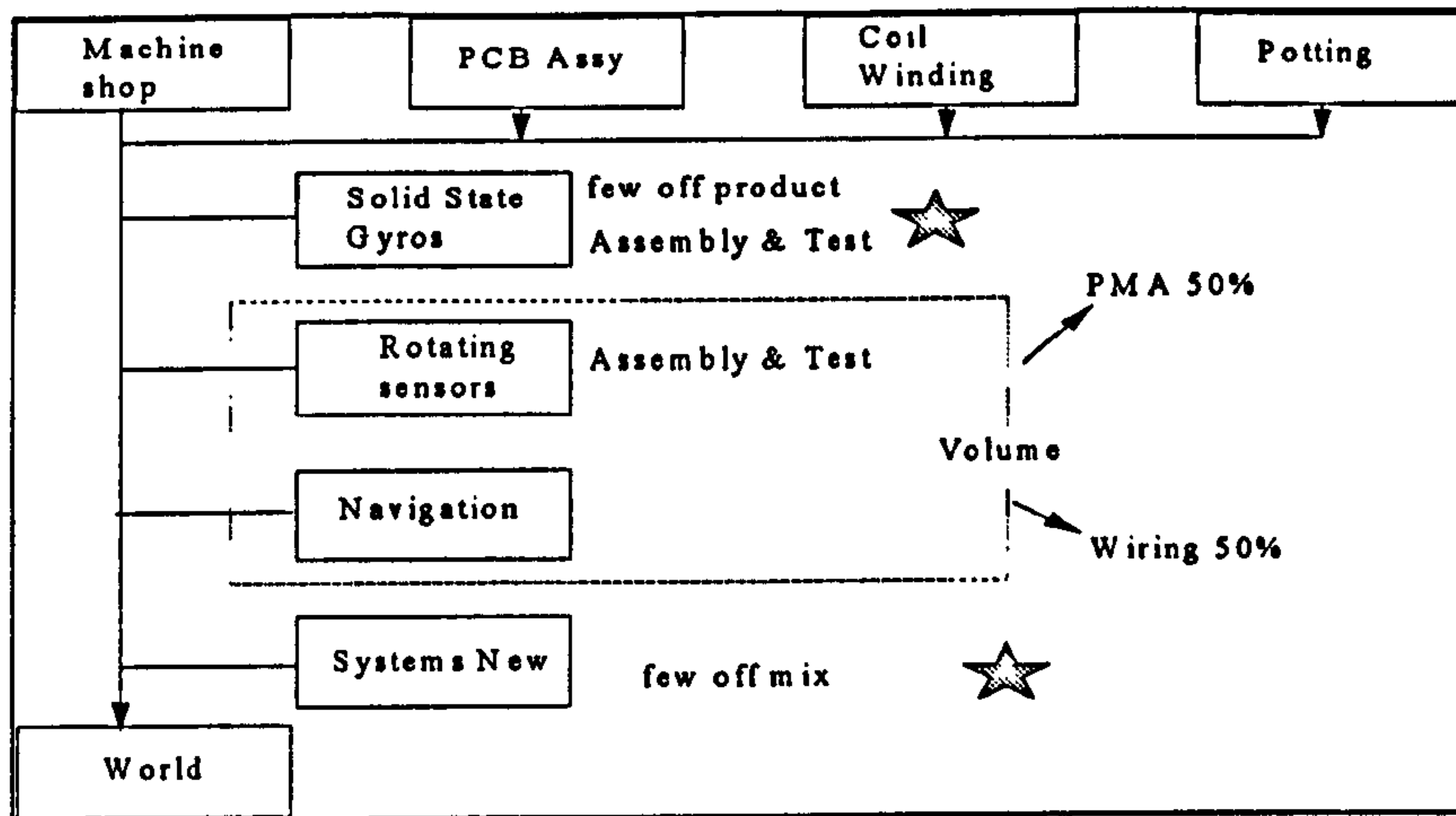

Manufacturing System Flows

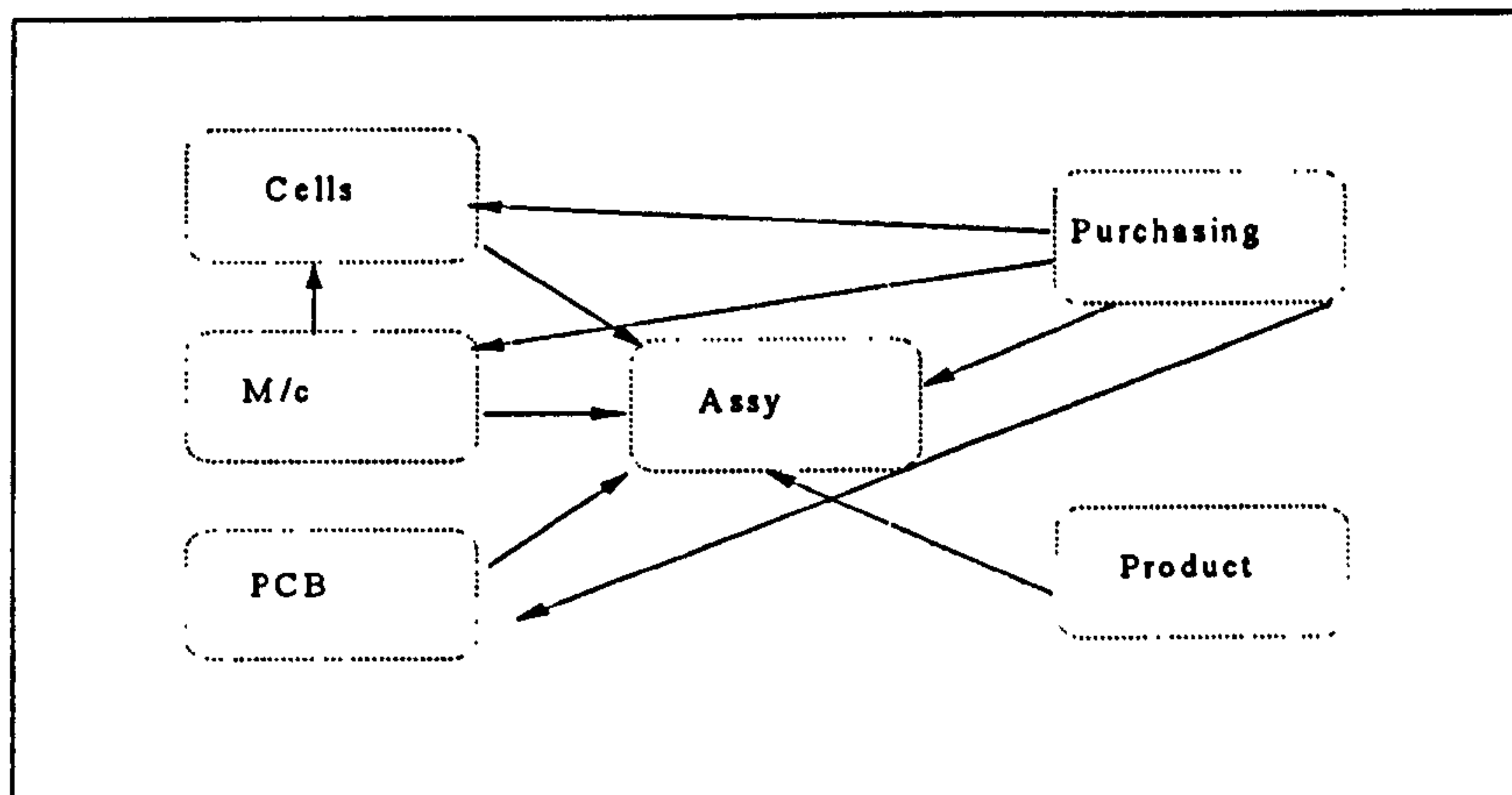

What is the role of Manufacturing?

- Manufacturing Directors view 'empty the order book at or below target cost'
- Chief Engineers view 'got to support the business in developing and achieving its order winners, in such a way that it gives a competitive edge, being better than anyone else'
- Manufacturing Team Leader's view: being aware of what the business is trying to achieve - being dynamic with an open mind

Organisation Chart for Case B Manufacturing

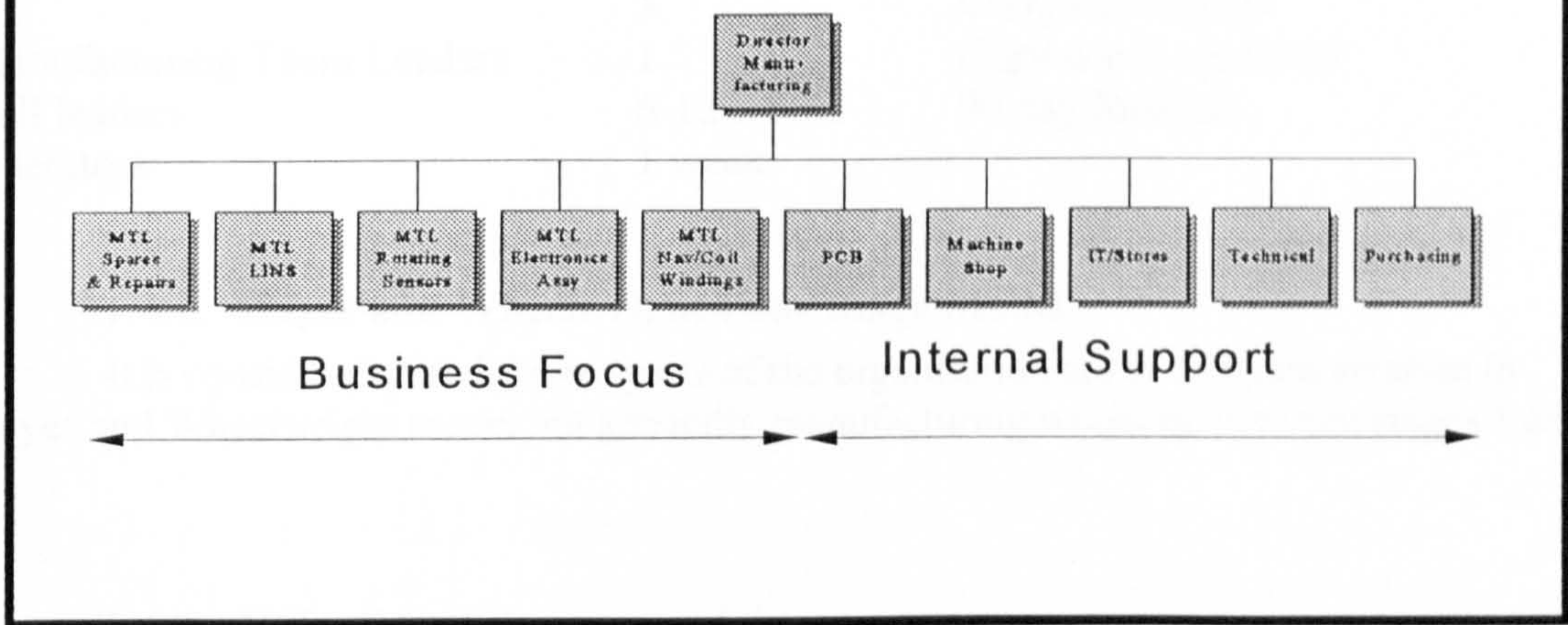

Customers expect the organisation to be innovative providing state of the art equipment. Looking at the development of new markets within the automotive and military industries

Order winners for one product group

- low cost
- high reliability
- delivery performance - short lead-times / call off orders

The product group is described as 'of the shelf'. The products are reducing in size all the time, the electronics to support the product now take up more space.

1.4. Process of Manufacturing Strategy Formulation

1.4.1. Point of Entry

The point of entry for Case C has been recognised by the interviewees, at the present time manufacturing's function is seen as supporting the business in fulfilling and selling out the order book. It is also considered important that manufacturing meets the requirements of the internal customer.

1.4.2. Participation

Manufacturing Director
Chief Engineer
Manufacturing Team Leaders
Supervisors

1.4.3. Project Management and Timescales

Cyclic

Responsibility	Horizon	Area to consider
Managing Director	10	UK change
	5	Company change
Manufacturing Team Leaders	1	Capital and appraisal
Cell leaders	6-12 weeks	90 day forecast
Operators	1 week	

1.4.4. Hayes and Wheelwright Four Stage Model

It is considered that different parts of the organisation are at different position in Hayes and Wheelwright model but generally manufacturing would be between stages 1 and 2.

1.4.5. Objectives

The mission statement of Case C is 'to be the leading European supplier of world class products in its chosen markets, operating with trust and integrity.'

The companies aim is to become a 'customer intimate' organisation. To do this the company is striving to understand its customers needs and wants, to reduce development lead times and to reduce the life cycle cost of their products. The company recognise the need to change and through current initiatives hopes to develop the organisational structure and culture to enable customer intimacy. The culture at the moment still appears to encourage firefighting, there appears to be a lack of trust and has been described as a 'blame' culture.

In the long term the following stretch goals were described as being important

- Build confidence of the internal users to ensure that manufacturing can support the business strategy.
- Build up process capabilities and capacity to ensure products can be manufactured on time and to the required quality
- Repairs
- Clean rooms - capacity and capability - [a 1 year lead time for a new clean room is required]

The critical success factors were described as being dispatch reliability - when a customer has an AOG [aircraft on ground] situation, the prompt delivery of the required component is critical to the operationability of the customer

1.4.6. Decision Areas

Inspection and test, Burring, Planning Information Technology, Assembly, Coil winding, Printer circuit assembly, Machining, Stores, Purchasing, Equipment replacement policy

1.4.7. Make or Buy Philosophy

Engineer to order	15%
Assemble to order	80%
Assemble to stock	5%

30% of the total product cost is contributed by the site. Remaining 70% is bought in.

1.4.8. Emergent or Planned - the process

There is no formal process in place for the development of a manufacturing strategy and consequently the update and renewal of a manufacturing strategy. In early 1995 an initiative was launched to link manufacturing strategy to the organisational improvement process. A great many people were involved in brainstorming issues and concerns and 30 initiative were launched as a result. The initiative has become 'Company B's Journey'. A room has been allocated as a central point for the initiative - more information is required as to the effects the initiative has had on manufacturing.

Over the longitudinal study several methods and Manufacturing Strategy Formulation Methodologies have been used. Each has had a varying successful completion. Each approach will be introduced as different IDEF models at the end of the case study.

Therefore it appears that the strategy is of an emergent nature, and is driven by new technology and the building up of competences in specific areas.

1.5. Cultural Issues impacting on Manufacturing Strategy

The culture at Case C has changed immensely over the past two years, prior to the reorganisation of parts of the business. Teams are becoming much more mutually supportive. It was felt that the business are moving towards a greater understanding of the differences between a product and a process.

1.6. Relevant System

Manufacturing Strategy Formulation Process

1.7. Emergent Manufacturing Strategy Archetypes

Aiming to become a World Class Manufacturing organisation. [SPC and a business process focus will be the main agents of change, New IT system will allow us to do things faster, Activity Based Costing] location of performance measures
This case study was presented as a paper at the 1995 NCMR conference.

Appendix Two

Phase 2 - Case D

Phase 2 - Case E

Phase 2 - Case F

Phase 2 - Case G

Phase 2 - Case H

Phase 2 - Case I

Phase 2 - Case J

1.1. Case Study D

The data collection was carried out using interviews, company documents and the Internet in May 1996.

1.1.1. Type of Case

Systems and Component Supplier

1.1.2. Participants

Operations Director

1.1.3. Source of data

Interviews, Company Documents, Individual Study

1.1.4. Validation

A letter with the initial write up was sent to the Operations Director shortly after the initial interview, these notes were verified and changed accordingly. The workbook developed in chapter 10 was also sent to the Operations Director with an invitation to comment on the validity and usability for practitioners. At time of writing no reply has yet been received.

1.2. General Company Background

Parent Organisation Strategy

'to be an international engineering group concentrating on specialised engineering businesses, operating in selected niches on a global basis, key businesses must be able to command positions of sustainable technological and market share leadership. They will have a high knowledge and service content and will be able to anticipate and meet customers needs'

1.2.1. Position in Supply Chain

Case D is part of the Parent group which has a turnover of \$2.7 Billion a year. Case D can be described as a Systems and Components Supplier within the UK aerospace supply chain and also in international markets.

1.3. Case D Manufacturing Organisation

Case D is a world leader in the manufacture of advanced technology propeller systems. The company has 50 years of experience in propeller manufacturing and concentrates its core business on medium to large composite bladed electronically controlled propeller systems. The main functions of the business are to design, develop, manufacture and support propeller systems.

The organisation is divided into 3 Directorates which consist of Manufacturing, Marketing and Sales, and Engineering. The directorates are functionally orientated with 5 hierarchical layers. The hierarchy is arranged as follows: Managing Director, Functional Directors, Managers, Team Leaders and Operators.

The manufacturing area is divided into 3 areas. Assembly, Blade manufacture, Overshoe manufacture.

The manufacturing process consists of the following - cutting and lay up of cloth, braiding, carbon fibre spar in mould, injection moulding, removing blade from mould, robotic polyurethane spraying. Finishing. 60 operations in the process, which has a lead time of 55 days.

Within the engineering area the teams are split into development engineering and stress, with the product groups split up as follows:

- Propeller, Control Systems, Electronics and Spares

Satellite assembly areas exist close to the customer in order to support assembly locally, and to enable the ability to recondition when necessary. An After sales section is based in the US -for use as a 'local repair shop'.

1.4. Process of Manufacturing Strategy Formulation

1.4.1. General

The manufacturing strategy formulation process is addressed on an annual basis. A mid term plan is formulated which pin points the issues that will have to be addressed in the next 3-4 years. The top level strategy is distributed to the managers for input and the emerging strategy is then translated into policies and specific goals. The sales forecast is a major input into the strategy and any desirable or feasible changes are budgeted against the forecast. Decision areas include facilities, Information Technology, Tooling etc.

The business plan is a direct output from the manufacturing strategy formulation process and is used to drive the management of performance indicators which are mainly customer driven i.e. delivery performance, rejects [both internal; and external], warranty claims, customer failures, maintenance hours per man hour. [18 critical success factors have been identified]

1.4.2. Point of Entry

In 1991 Case D was a large organisation with a 'mass' of products. A decision was taken to split the company in to focused factories, which would each become self contained units. The factory was set up to manufacture composite blades. A decision was taken to sub contract out some of these activities.

1.4.3. Participation

The Operations Director and Managers formulate the mid term plan.

1.4.4. Project Management and Timescales

Annual cycle.

1.4.5. Hayes and Wheelwright Four Stage Model

The organisation appears to be between stage 2 and 3.

1.4.6. Objectives

Case D is described as being one of the worlds premier propeller system design, manufacturing and support companies. It is Case D's aim to be the 'preferred partner' of all its customers. It is committed to the concept of service and response to the market. Cross company commitment to quality is cited as being the enabler of customer satisfaction.

Major objectives include

- Responsive and supportive
- On time delivery
- Engineering excellence
- Cost effective manufacture
- Quality

- Product support

The stated strategy for Case D *'to become the worlds leading supplier of advance technology propeller systems'*

Other objectives

- To grow from a volume of 23 units a week to 50.
- Develop the core processes
- Introduce further plants
- Introduce further moulds
- Employ further people.
- Multi media
- Standardised communication between the corporation and other companies [mainly for commercial reason]
- New innovations

1.4.7. Manufacturing Strategy Enablers

- Concurrent Engineering Environment
- Keep control of manufacturing - core activity
- Local environment - develop good relationships with local suppliers to develop local people, the local cost base and the local environment, need to keep confidence levels high.
- Sub contracting non core activities. The relationship with suppliers used to be adversarial, this is changing now as relationships are becoming mutually rewarding. Moving towards a JIT environment - not necessarily JIT but receiving goods in a timely manner. The supplier is expected to build in quality at each manufacturing operation.
- People - there has been a problem in replenishing the knowledge base of the organisation. With the reorganisation into focused factories the loss of staff and their knowledge was difficult.
- Develop the supply base locally - within a 50 mile radius
- Final assembly - close to the customer

1.4.8. Decision Areas

The supply base was described as being 'so poor' with the average supplier in aerospace cited as not having specific skills in the following areas:

- operator inspection
- capacity planning
- lead-times
- planning
- statistical process control
- little design expertise

1.4.9. Technologies

Resin transfer moulding.

Competence in stress, strain, aerodynamics, bonding

Composites and electronics

1.4.10. Make or Buy Philosophy

At the top level - everything has been subcontracted out apart from the 'core competence' which is 'injection resin moulding of carbon fibre composite blades'.

All engineering is in-house, this may be sub-contracted out at a later date but is not current policy.

1.4.11. Emergent or Planned - the process

The Manufacturing Strategy Formulation Process appears to be a planned activity from the information provided.

1.5. Cultural Issues impacting on Manufacturing Strategy

The culture of the organisation appeared to be trusting, flexible and as honest as possible. All the employees eat in the same canteen, have the same working hours, holidays and sickness benefits. The management team do not have too many extra privileges - these being a company car and pension scheme. An employee council has been set up and has become a great asset to the company. The council are briefed and kept abreast of issues. The Operations Director knew everyone by name during the factory visit. The culture has changed dramatically. Rotol days, the culture used to be described as 'little flexibility'.

1.6. Change Programmes resulting from the Manufacturing Strategy

Quality Management is seen as being extremely important to the successful implementation of the manufacturing strategy. ISO 9000 is the quality system model used as the enabler. The experience of the company was that implementation was hard work, but benefits had been gained. The performance measures included rectification, vendor performance, concession both internal and external, internal rejects and scrap. Meetings are held to address any major problems. Quality circles have been set up at operator level to address problems on the shop floor. The frequency of these meetings are every other day for 1/2 an hour - nicknamed the 'sunrise meetings'. 4 audits are carried out each year on each operator. If they fail the audits twice, the stamp is taken away from them, and they have to work under the direction of an inspector. The operators are directed to stop their operations if any resources required are unavailable. A few problems were encountered initially, however after an 'amnesty' improvements were soon seen.

Future plans include the introduction of cellular manufacturing within the Hercules product group - this would use joint resources such as the lath and the Poly robot. There are plans to introduce the focused factory concept, however at this stage the duplication of plant would not be justified due to under utilisation. At the moment the idea does not make economic sense. However with the development in the market this may be the way the factory develops.

1.7. Relevant Systems

The relevant system identified for use in chapter 7: the Manufacturing Strategy Formulation Process.

1.8. Emergent Manufacturing Strategy Archetypes

The Order Winners and Qualifiers within the propellers market were described as the Process, Technology and Customer Support.

Key benefits and features include:

- proven , rugged, all composite blade construction
- advanced electronic control system,
- minimum technical risk through proven technologies
- simple lightweight design
- advanced aerodynamic blade sections
- low noise and vibration
- modular configuration
- low life cycle cost

Looking outward from the point of view of resin transfer moulding.
Competence in stress, strain, aerodynamics, bonding

Composites and electronics

1.9. The root definition

A system to: produce a manufacturing strategy by developing the business plan and change management programme *by means of:* performance indicators, sales forecast data and other manufacturing information *in order to:* feed into the organisation's mid term plans.

- Customers:**
 - The Managing Director
- Actors:**
 - Operations Director
- Transformation:**
 - Sales forecast and decision areas information transformed into the business plan and change management programme
- Worldview:**
 - Business planning / Market led based on sales forecasts
- Owner:**
 - Operations Director
- Environment:**
 - Steady business

1.10. Conceptual models - IDEF0 Models of the relevant system.

1.10.1. Manufacturing Strategy Formulation Process

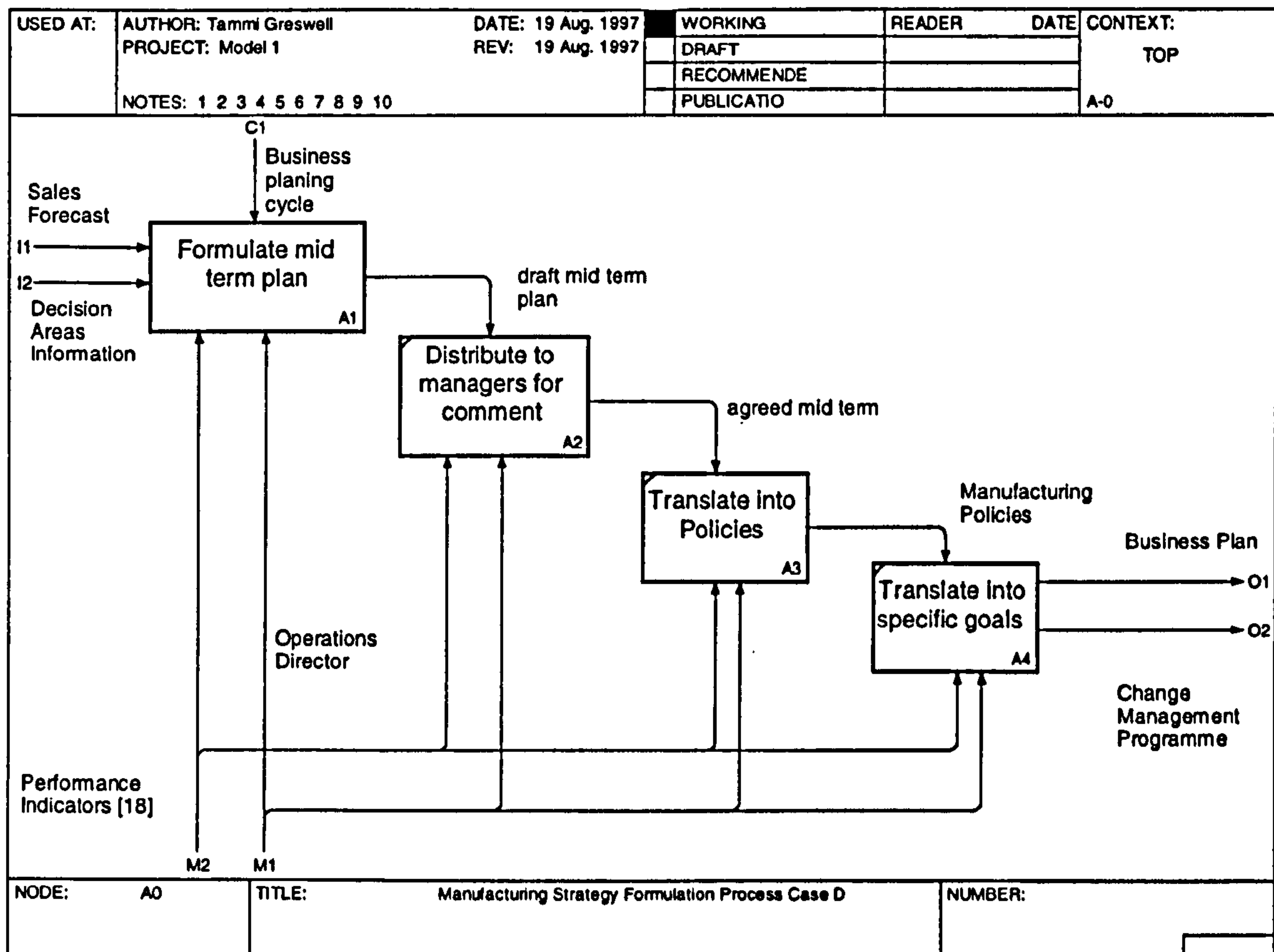

T

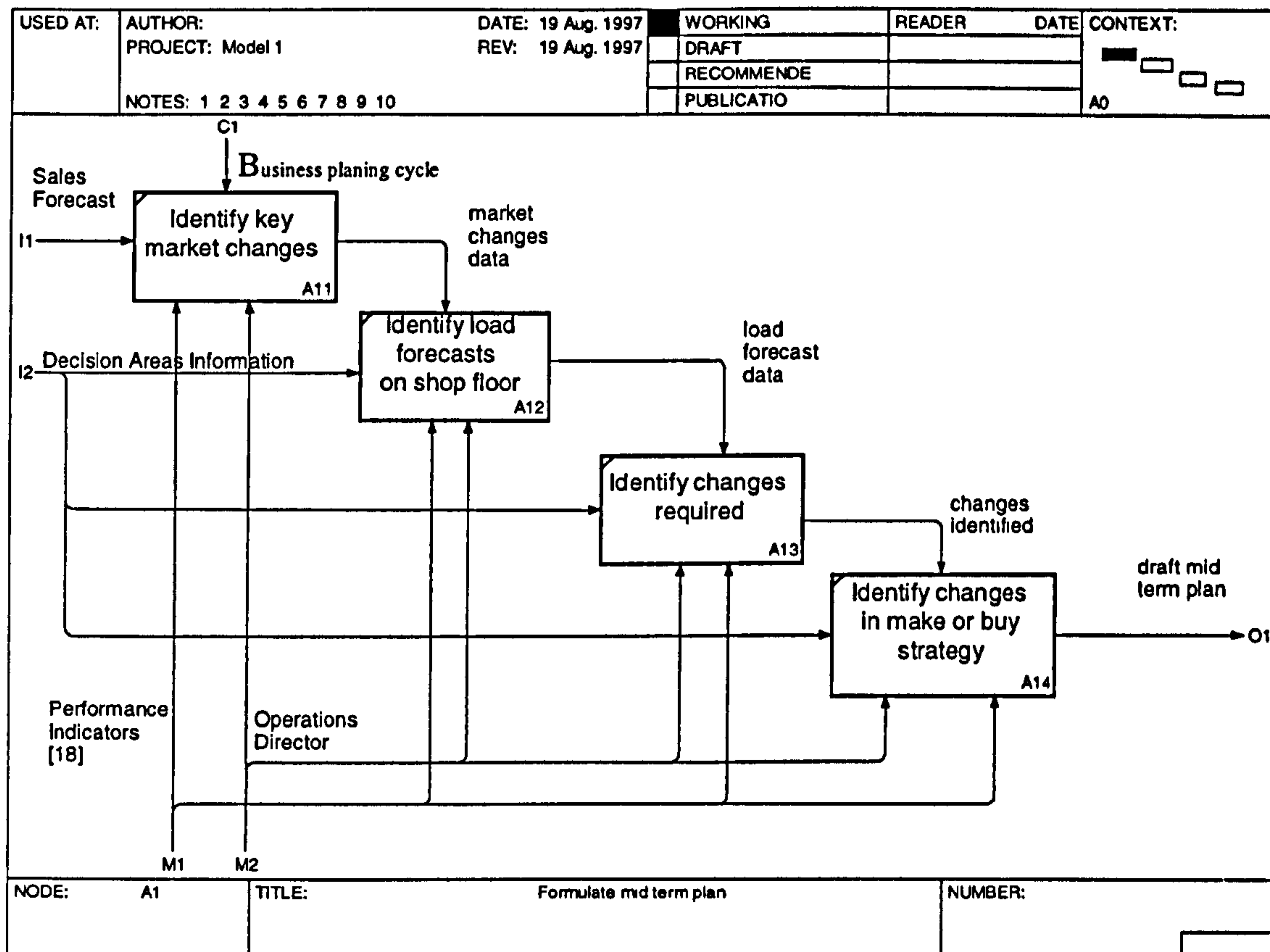

NODE:	A1	TITLE: Formulate mid term plan	NUMBER:
-------	----	--------------------------------	---------

1.1. Case Study E

The collection of data has been carried out using a series of interviews, workshops and meetings over a 3 year period from October 1994 to August 1997.

1.1.1. Type of Case

Systems and Component Supplier

1.1.2. Participants

Manufacturing Director
Chief Engineer
Research and Development Manager
Manufacturing team Leaders
Purchasing & Supply Director
Graduate Engineer
Cranfield Researchers - CAMSD Project

1.1.3. Source of data

Interviews, Workshops, Company Meetings, Company Video, Company Documents, Longitudinal Study, The Internet.

1.1.4. Validation

The data gathered over the 3 year period has been continually validated and updated through a close working relationship with the organisation. The workbook developed in chapter ten has benefited greatly from the input of the organisation.

1.2. General Company Background - Organisational Structure

The general background can be found in case c, as this case is a continuation and longitudinal study of the organisation.

1.2.1. Position in Supply Chain

Case E can be described as a Systems and Components Supplier within the UK aerospace supply chain and also in international markets.

1.3. Process of Manufacturing Strategy Formulation

1.3.1. Point of Entry

The point of entry for Case E has been described in case c. However, the organisation has moved on from the original approach and has changed its view to that of using an incremental change program to develop a competitive edge within the manufacturing organisation

1.3.2. Participation

Manufacturing Director
Chief Engineer
Manufacturing Team Leaders
Supervisors

1.3.3. Project Management and Timescales

The project does not have an end at this stage

1.3.4. Hayes and Wheelwright Four Stage Model

It is considered that different parts of the organisation are at different position in Hayes and Wheelwright model but generally manufacturing would be between stages 1 and 2. No change from the initial case study.

1.3.5. Objectives

To develop an incremental approach to change, and to instill a culture of continuous improvement.

1.3.6. Decision Areas

As case C

1.3.7. Technologies

As case C

1.3.8. Make or Buy Philosophy

As case C

1.3.9. Emergent or Planned - the process

The process is still emergent in nature

1.4. Cultural Issues impacting on Manufacturing Strategy

As case c, however the work done which was described in case c has imparted a changing culture – moving towards a no blame culture – however it still appears that it has a way to go.

1.5. Relevant System

The 'journey'

1.6. Emergent Manufacturing Strategy Archetypes

Aiming to become a World Class Manufacturing organisation

1.7. The Root Definition for the journey - *The Change Management Process*

A system to: manage and implement change within the organisation as a whole (including the manufacturing organisation) *by means of:* using the 'journey' *in order to:* support the corporate value plan and business plan.

- | | |
|---------------------------|--|
| Customers: | • Customers and employees |
| Actors: | • Employees |
| Trans – formation: | • to become the benchmark organisation for their industry sector |
| Worldview: | • change is necessary to survive |
| Owner: | • The executive |
| Environment: | • Global competition |

1.8. IDEF0 Models of the relevant systems. 'The Journey'

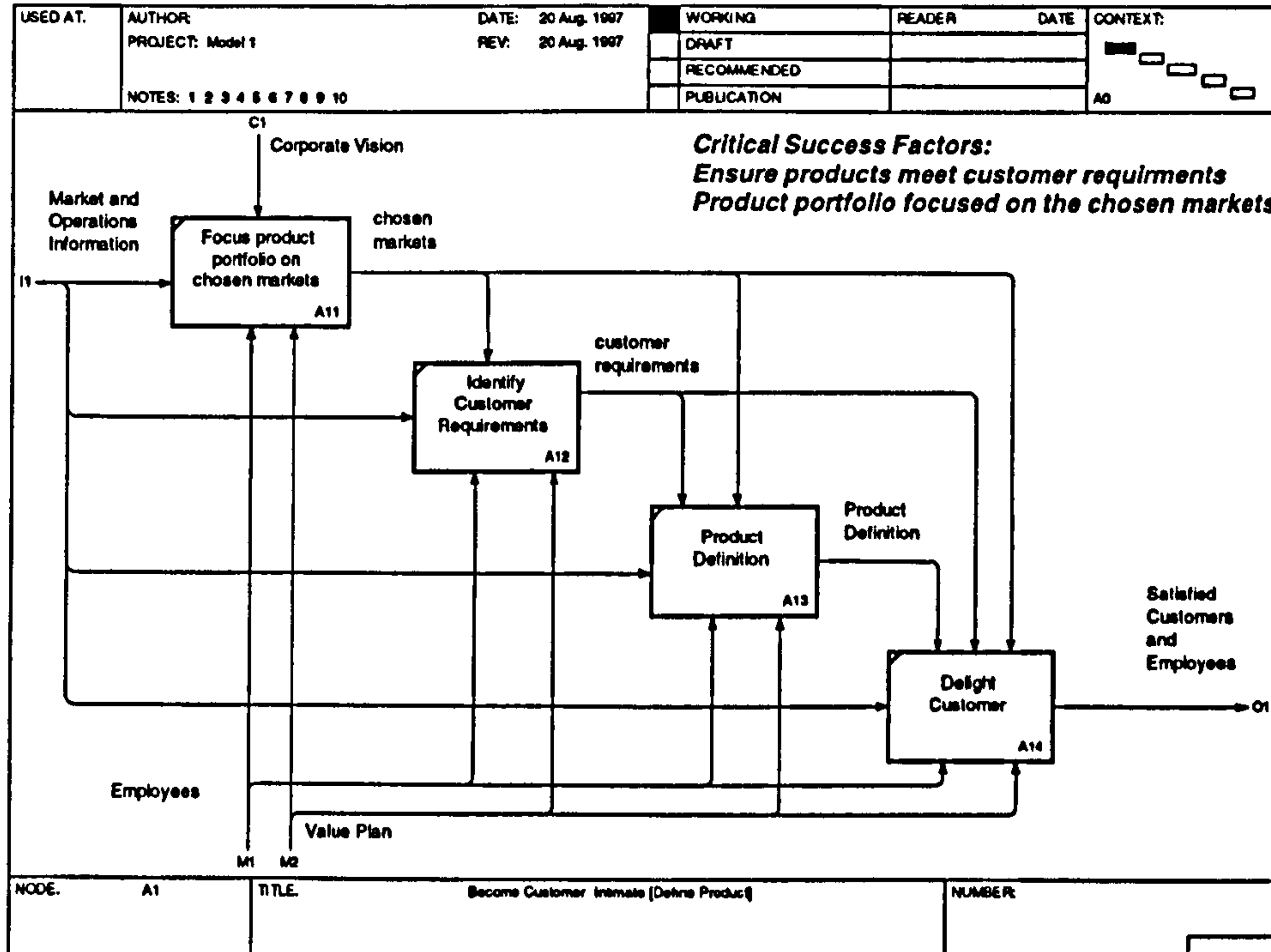
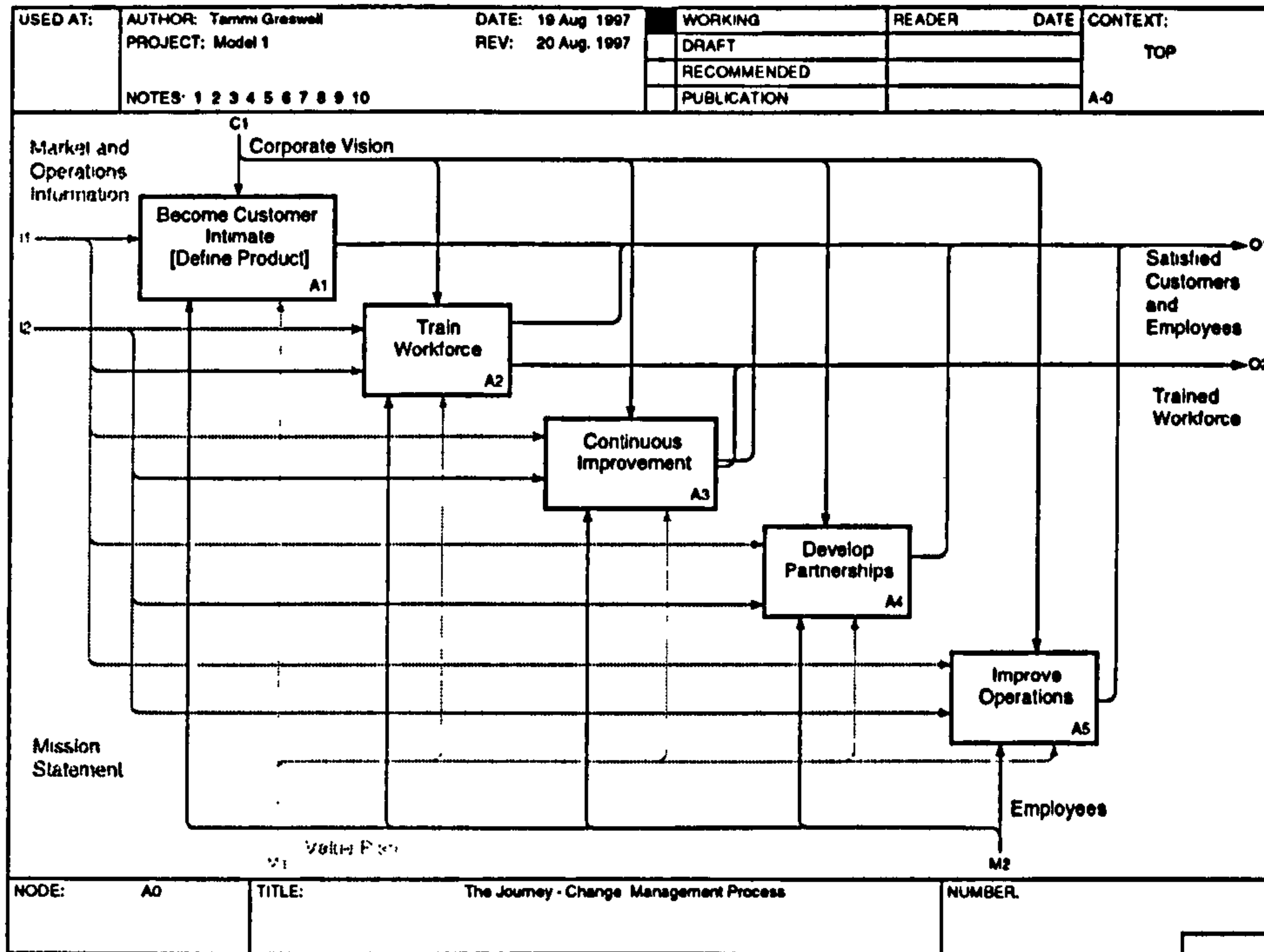

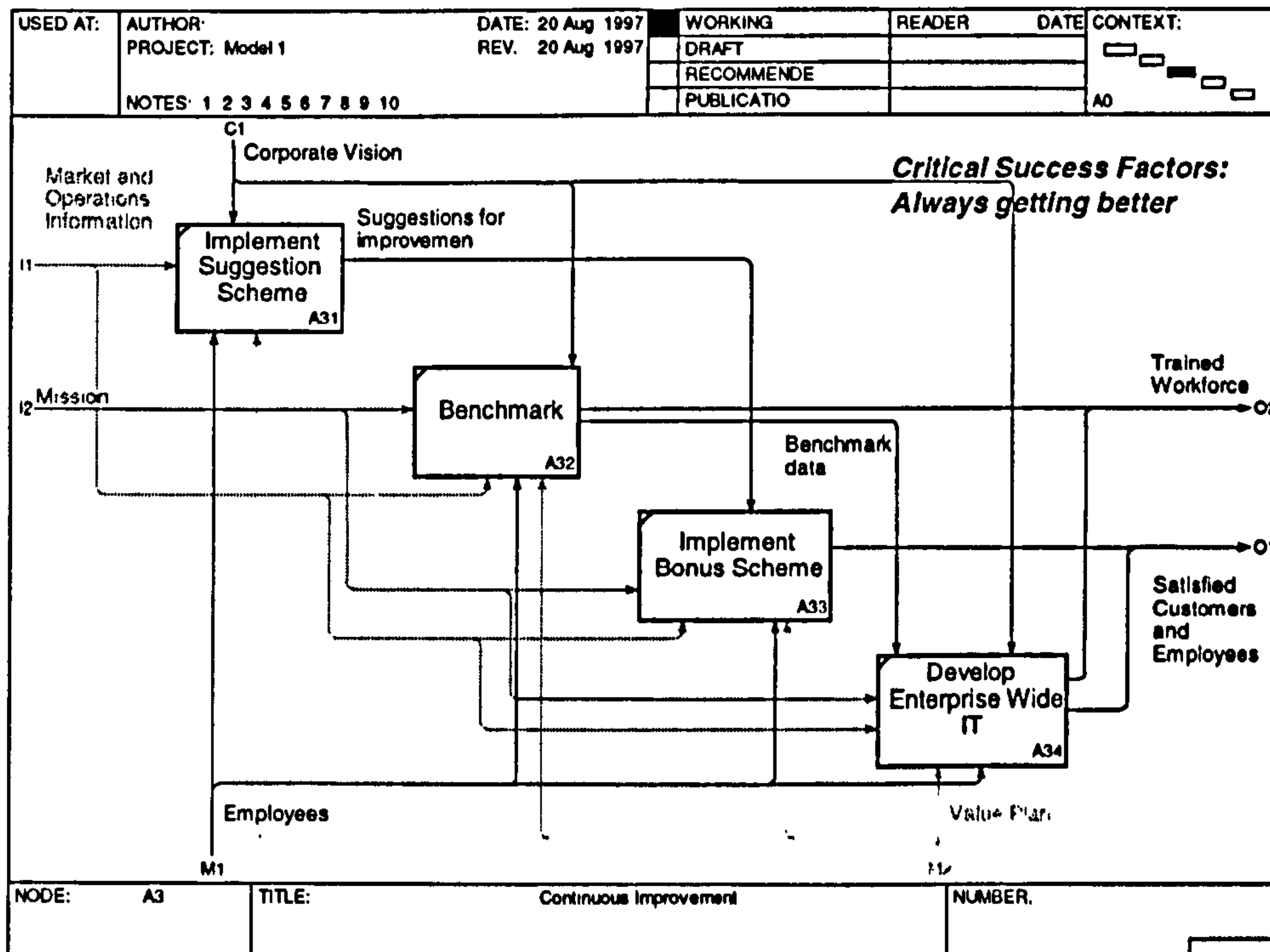
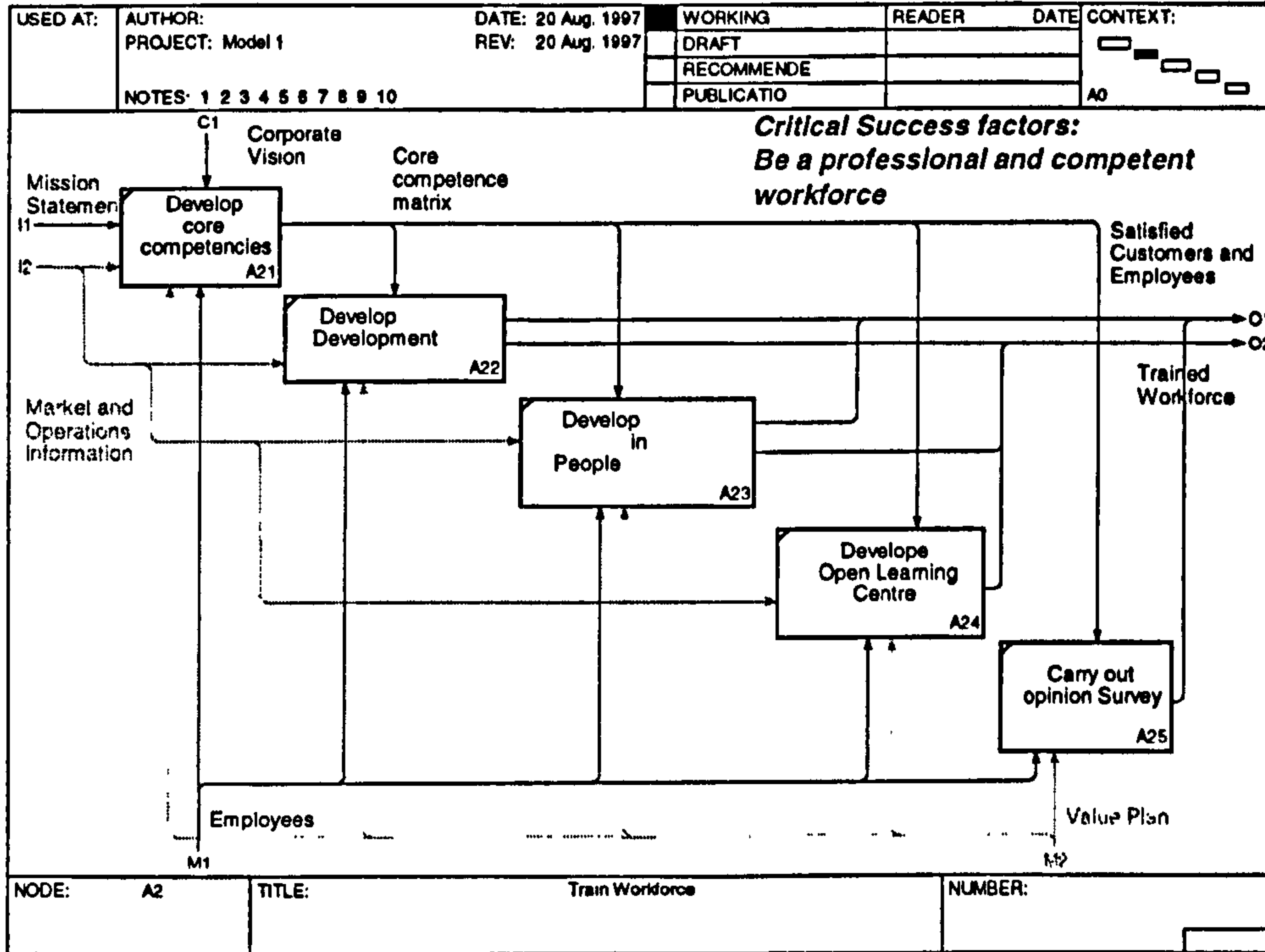

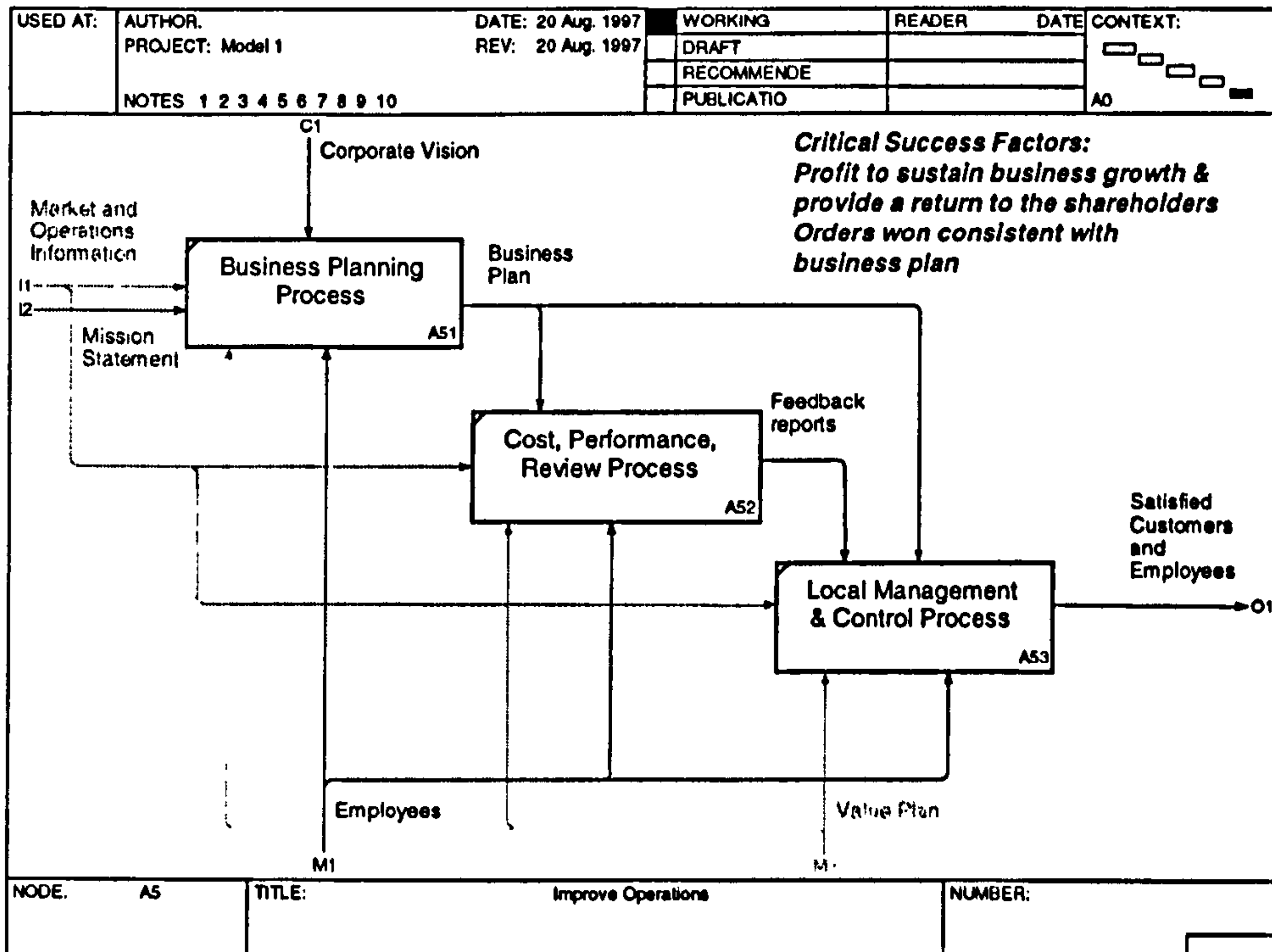
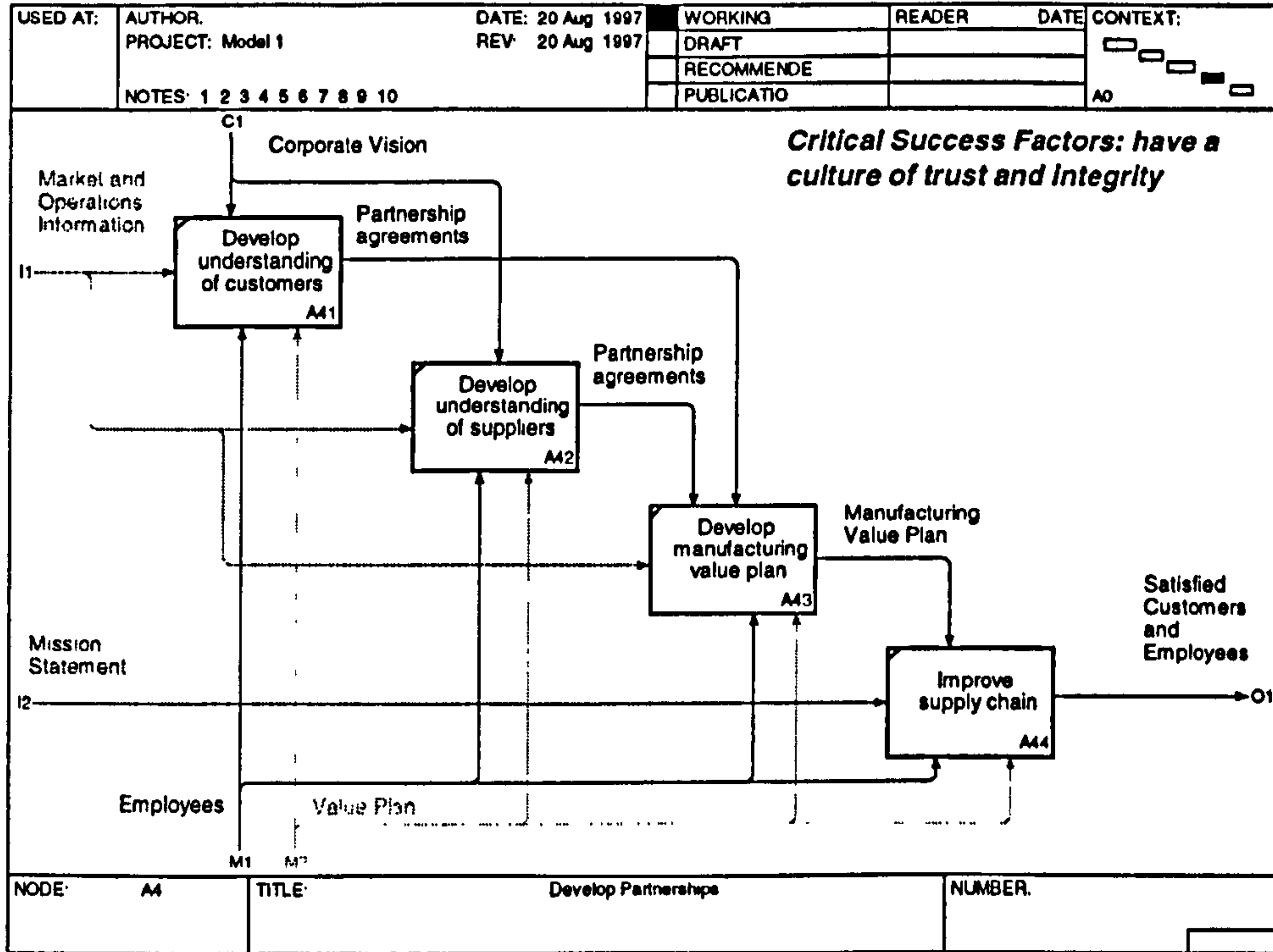

1.1. Case Study F

The data collection was carried out using interviews, company documents and the Internet in June - August 1996.

1.1.1. Type of Case

Systems Supplier.

1.1.2. Participants

Operations Director.

1.1.3. Source of data

Interviews, Company Documents, Individual Study, The Internet.

1.1.4. Validation

The data gathered has been validated and updated through correspondence with the Operations Director. The workbook developed in chapter 9 has been sent to the organisation for comment.

1.2. General Background

The Operations Director's rich picture of the future of manufacturing.

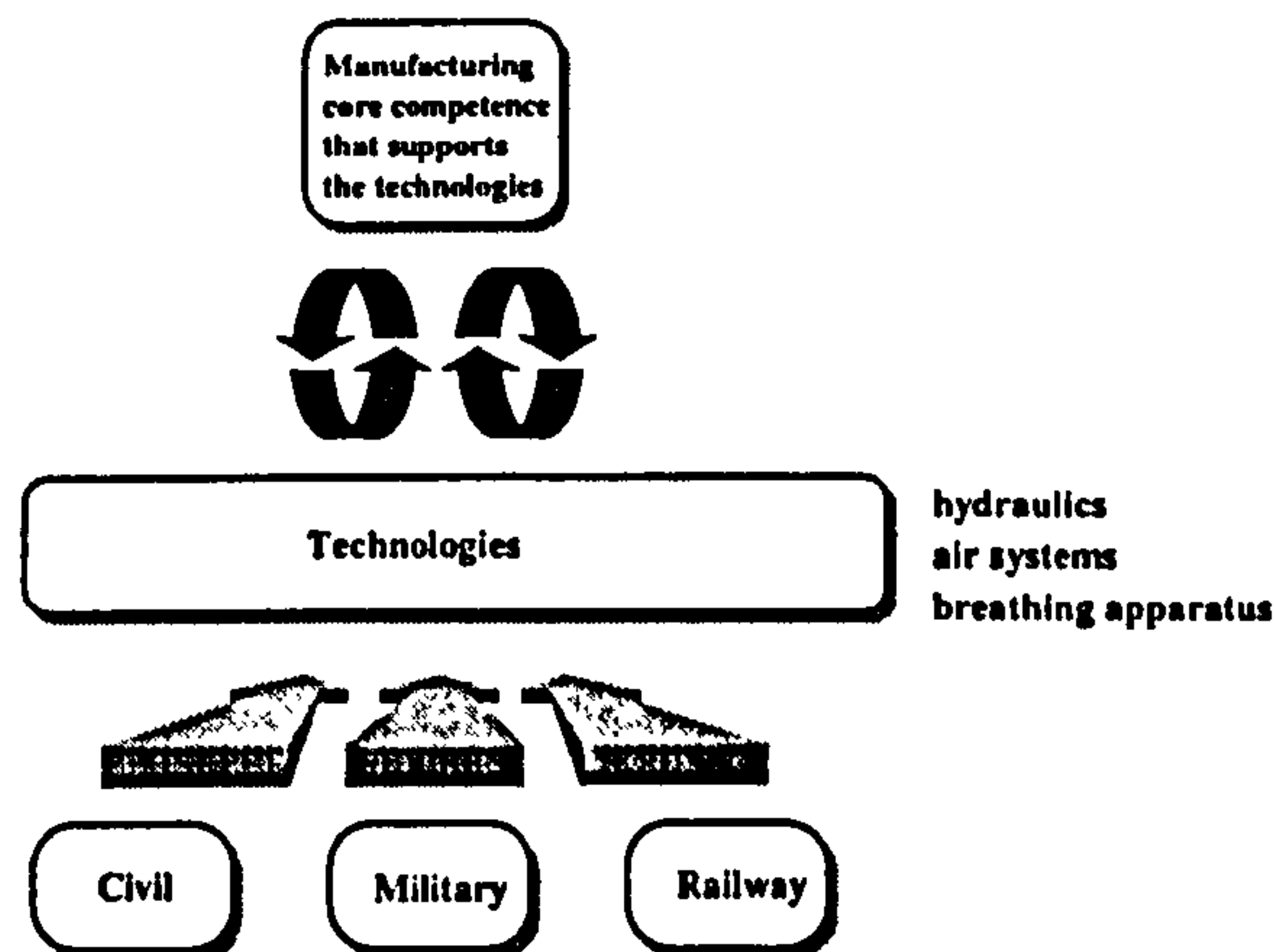

Figure 22

1.2.1. Position in Supply Chain

Case F can be described as a Systems Supplier within the UK aerospace supply chain and also in international markets.

1.3. Case F - The History of the Manufacturing Organisation

1990 - It became apparent that a fundamental change was required to manufacturing within Company F, this was driven by a performance improvement need to reduce long lead times and to reduce high scrap rates. A new MD was appointed in 89 and it was evident that the management team wanted to implement cells within the manufacturing environment. There were two main inhibitors to this change:

1. the marketing information was not available to justify the cost.

2. the Operations Director did not want to change.

1992 - At the same time as implementing manufacturing cells the working practices on the shop floor changed. As a consequence of implementing cells 'change became the norm' due to the newly created atmosphere. Some 6 months later it became apparent that to obtain further benefit the administration structure needed a reorganisation and the following areas were restructured:

- machining
- assembly
- production
- materials
- sub contract

The above were reorganised into a concurrent engineering structure with team responsibility for order acceptance through to delivery. Engineers were moved out of their offices and onto the shop floor. This was completed in 1994.

1994 - the Operations Strategy goals were described as:

- cost reduction [20% reduction in time]
- delivery performance
- scrap and rework reduction
- inventory reduction
- lead time reduction [60% reduction]

These goals were brainstormed out to come up with a set of actions with people assigned to tackle each action. The criticism leveled at this approach was that all issues were little things, no time scales were set for completion and several of the projects are still running 2 years later

Another area visited in 1994 was the fundamentals of make or buy. A team was taken off site to review make or buy. A pareto analysis was used to look at the parts made and the time taken to manufacture. The objective of this exercise was to reduce the 'noise' within the manufacturing system. A decision was taken to reduce the number of parts within the current library from 4000 to 700 keeping 75% of the hours. The benefits of this was a more effective set up, less variability on the shop floor and allow the rationalisation down to 1 kit of parts from sub contacts and bought out parts. The other side of the coin was the desire to ensure that a sourcing problem was not created.

The product range was also considered in the make or buy equation. With several units being resourced as bought out complete. Production managers were tasked to carry out a full make or buy analysis on all generic units taking into consideration the core competencies they wanted to keep. Both technical competencies and key skills. The unions were kept in full consultation whilst this process was ongoing - a decision was taken to implement the changes whilst the business was buoyant. At this stage the company had a lot of capabilities, however in some areas the equipment was aging and needed to be replaced. This was an ideal time to consider what competencies were CORE to the business. The aim of the company at this time was to become a world class manufacturing company.

94-95 - the cell structure was implemented and is currently evolving. The machines had initially been grouped according to part families [group technology] which resulted in the assembly areas located upstairs and the machining cells downstairs. The plan was to evolve the assembly cells into the machining areas to become product cells. This had been the goal from day 1.

Preparation for the implementation of cells

- planned to reconfigure the machining facilities
- developed the means of data capture to go in the cells
- looked at the layout

- issues of operator control
- flexibility of labour

The Product Cells

cell leader who is accountable and responsible to the production manager
people are moved around when required however workload does not excessively change from 1 week to the next.

A	finishing cell	
B	valves	machining and assembly
C		machining and assembly
D		machining and assembly
E		machining and assembly
L	solenoid cell	

structure - difficulties for chain of command, health and safety.

skills - the mismatch is difficult to manage, difficult to move people across disciplines due to skills and training and Health and Safety.

evolved to a product focus through the make or buy activity [trigger].

1.4. Process of Manufacturing Strategy Formulation

1.4.1. General

The Corporate strategy is articulated as '*Success through valued service*' this is taken by the business units and flowed down as a company strategy in order to satisfy corporate needs. The functional strategies are then formulated with the business strategy in mind. Case F is involved in the Civil and Military Aerospace Industry and the Railway.

The Manufacturing Strategy Formulation Process appears to be emergent in nature as a result of both external and internal stimuli. No formal process is followed however the performance measures are linked back to the articulated strategy 'success through valued service'. These measures also take into account the order winning and qualifying criteria. A business information systems was set up to control these measures. This was to enable good visibility of a series of measures and objectives which were set up within the cells. These metrics have been reduced through out the year and the metrics have become customer focused. The delivery to customer measure is considered most useful.

1.4.2. Point of Entry

If the Manufacturing Strategy Formulation Process at Case F is seen as emergent, the introduction of cellular manufacturing can be taken as the current Manufacturing Strategy Formulation process. The point of entry for the introduction of cells was provided by external stimuli. The main goal was to improve performance and reduce inventory.

A benchmarking activity was carried out to determine what current levels of performance were like. The measure was the number of hours to do the job. It was decided to reduce the figure by 15%, with a 60% reduction of lead Time and a reduction in Inventory.

1.4.3. Participation

Engineering and the Operations Director.

1.4.4. Project Management and Timescales

No data provided - emergent process

1.4.5. Hayes and Wheelwright Four Stage Model

Case F appears to be at stage 2.

1.4.6. Objectives of the introduction of the cells

The main objectives were as follows:

- reduce scrap
- reduce rework
- improve conditions - become a place of pride and corresponding improvements in pride

The teams were trained in improvement tools and techniques, however statistical process control is used variably, but not by the lads on the shop floor. The aim is to encourage ingenuity. Ongoing training. A skills matrix has been developed to show where skills are. Helps having a very responsive workforce.

Overall objectives for Manufacturing:

<i>Long term</i>	<ul style="list-style-type: none">• delivery on time for OEM• schedule adherence	Product cells would lead to a better schedule adherence
<i>Short term</i>	<ul style="list-style-type: none">• profit to shareholders• spares	World Class Manufacturing - reduce costs - increase profits

There is an apparent conflict between the long term and short term goals, and it appears that the 'goal posts' are changing. Shareholders want their returns to increase and the customer wants cheaper prices.

1.4.7. Manufacturing Strategy Enablers

- technical competence
- ability to solve technical problems
- price - now just ahead of delivery [a change of focus]
- delivery
- reliability
- after sales support

1.4.8. Decision Areas

Products - originally had a large number of lines, jobbing - hi-technology, 'have a go at everything strategy'.

Supply chain strategy - very important in the aerospace industry..

Preferred Supplier Status is very important as all major Prime Contractors have taken McDonnell Douglas's lead and have started awarding suppliers bronze through to gold awards.

Procurement is still seen as a central function, subcontract was split up and then put back, due to planning,

1.4.9. Make or Buy Philosophy

The product areas were simultaneously re-addressed with the make or buy activity. OEM and out of production spares were separated into different product groups at the end of 1995. Out of production spares were outsourced where possible in order to reduce the noise as much as possible 'drained a few of the swamps'.

<i>OEM - Original Equipment Manufacturers</i>	<input type="radio"/> products produced for all current production aircraft
<i>Spares</i>	<input type="radio"/> aircraft that are no longer manufactured but require spares e.g. buccancer, viper

- new business development

1.4.10. Emergent or Planned - the process

The Manufacturing Strategy Formulation Process appears to be emergent

1.5. Cultural Issues impacting on Manufacturing Strategy

The culture was described as 'fear used to be terrible', the culture is now described as being a lot more relaxed, with the team working together with no politicking and no wars.

The aspect of Continuous Improvement was all tied up within the culture of the organisation. A Total Quality Management programme was initiated in 1988, all employees were sent on a two day course, however the guys did not buy into the TQM programme thus creating a lack of credibility. A few problems grew within the programme, it became 'a bit like the Gestapo'. No measurements or plans were initiated, the Continuous Improvement initiatives were not focused on business needs. The programme appeared to be 'bolted on'.

The Continuous Improvement programme has moved on from the initial problems, the metrics introduced have ensured that Continuous Improvement is built into the culture and is seen as routine. Initiatives are driven down from management with more empowerment. It is recognised that the 'hearts and minds' are important and that these will only be won if the values of the company are communicated and accepted.

There is now no Management restaurant - all use the canteen, company cars are still kept for senior Management.

Key points:

- sensible approach to the trade unions
- open and honest dialogue
- good working relationships
- good level of communication

1.6. Change Programmes resulting from the Manufacturing Strategy

The core delivery processes have been identified as:

- Engineering
- Manufacturing
- Repair

It is envisaged that the processes will be managed via account managers. One account manager for each market sector. The account manager would be responsible for communicating with sales and marketing, engineering manufacturing etc. to ensure the customer had one contact within the company to be able to track their orders.

MD nearing retiring age, therefore may not want to change things too near to retirement.

General Comments

- 'need to get out of the functional silos'.
- Operations are the only area where performance is measured.
- Still firefighting - satisfying the corporation day to day - not addressing the long term issues - maybe the market is too volatile.
- Team dynamics - still functional.
- Day to day quality should be part of operations and engineering.

- Most aerospace organisations are moving towards assembly-to-order

1.7. Relevant Systems

Manufacturing Strategy - Cellular Manufacturing Environment Implementation Process.

1.8. Emergent Manufacturing Strategy Archetypes

Tends to move towards the World Class Manufacturing Strategy Archetype.

1.9. The Root Definition

A system to: implement cellular manufacturing *by means of:* identifying current manufacturing processes, what to make or buy and operations goals *in order to:* improve the performance of operations

- | | |
|------------------------|---|
| Customers: | • Operations Director |
| Actors: | • Operations director and employees |
| Transformation: | • No Cells to Cellular Manufacturing |
| Worldview: | • A Cellular layout is a good philosophy and mechanism to organise operations in order to improve performance |
| Owner: | • Operations Director |
| Environment: | • Company Policy |

1.10. IDEF0 Models of Manufacturing Strategy - Cellular Manufacturing Implementation Process

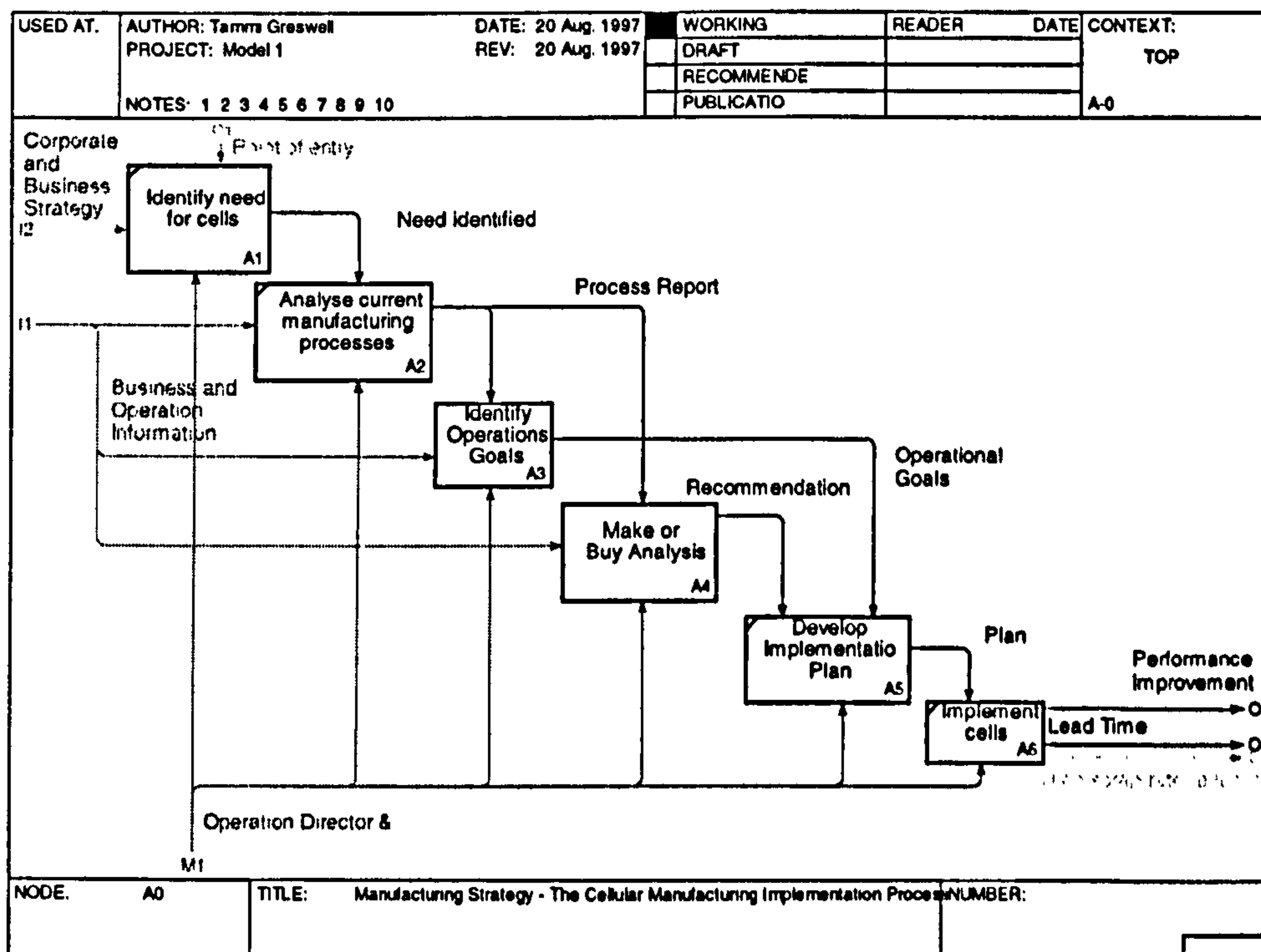

Appendix 2
case_f.doc

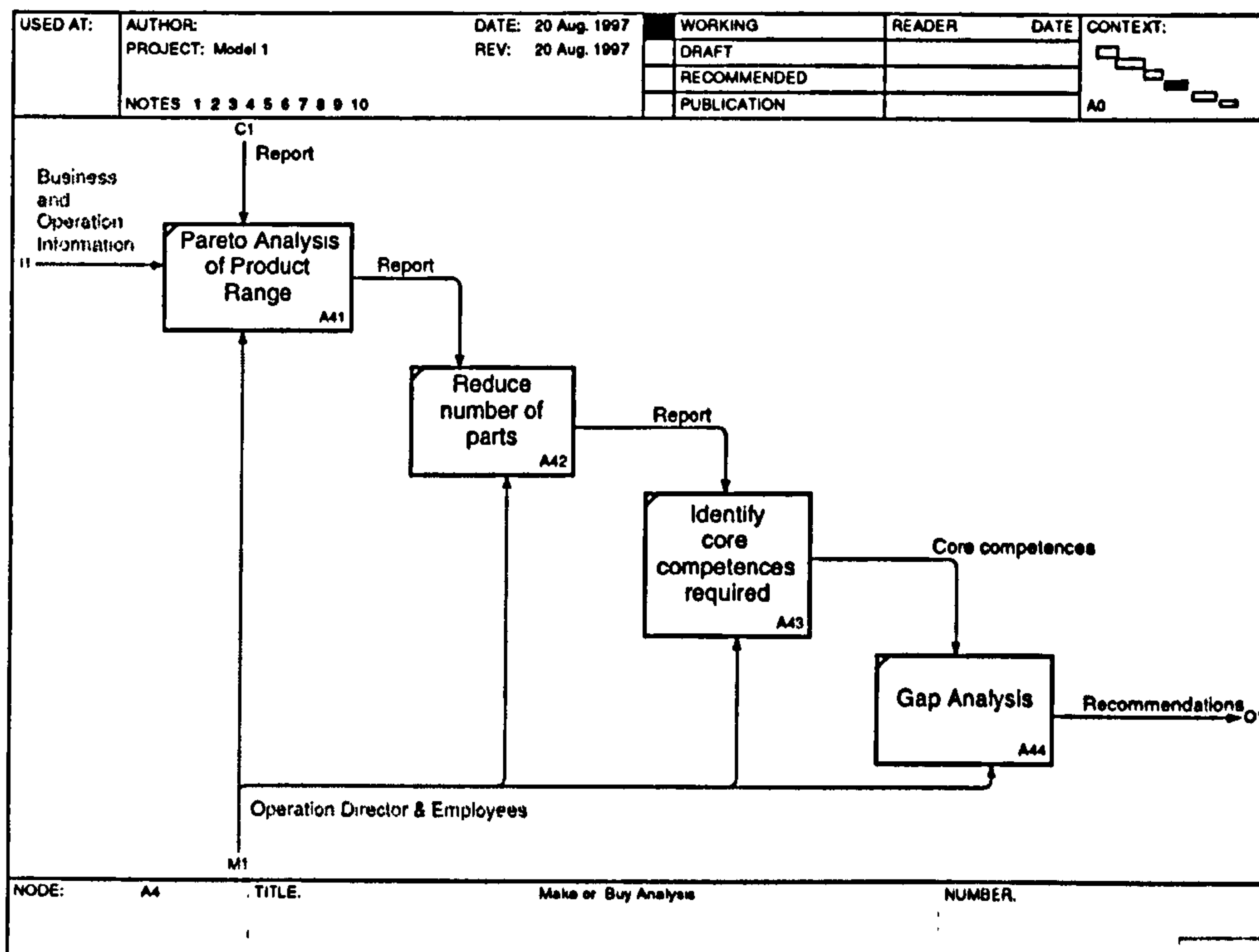
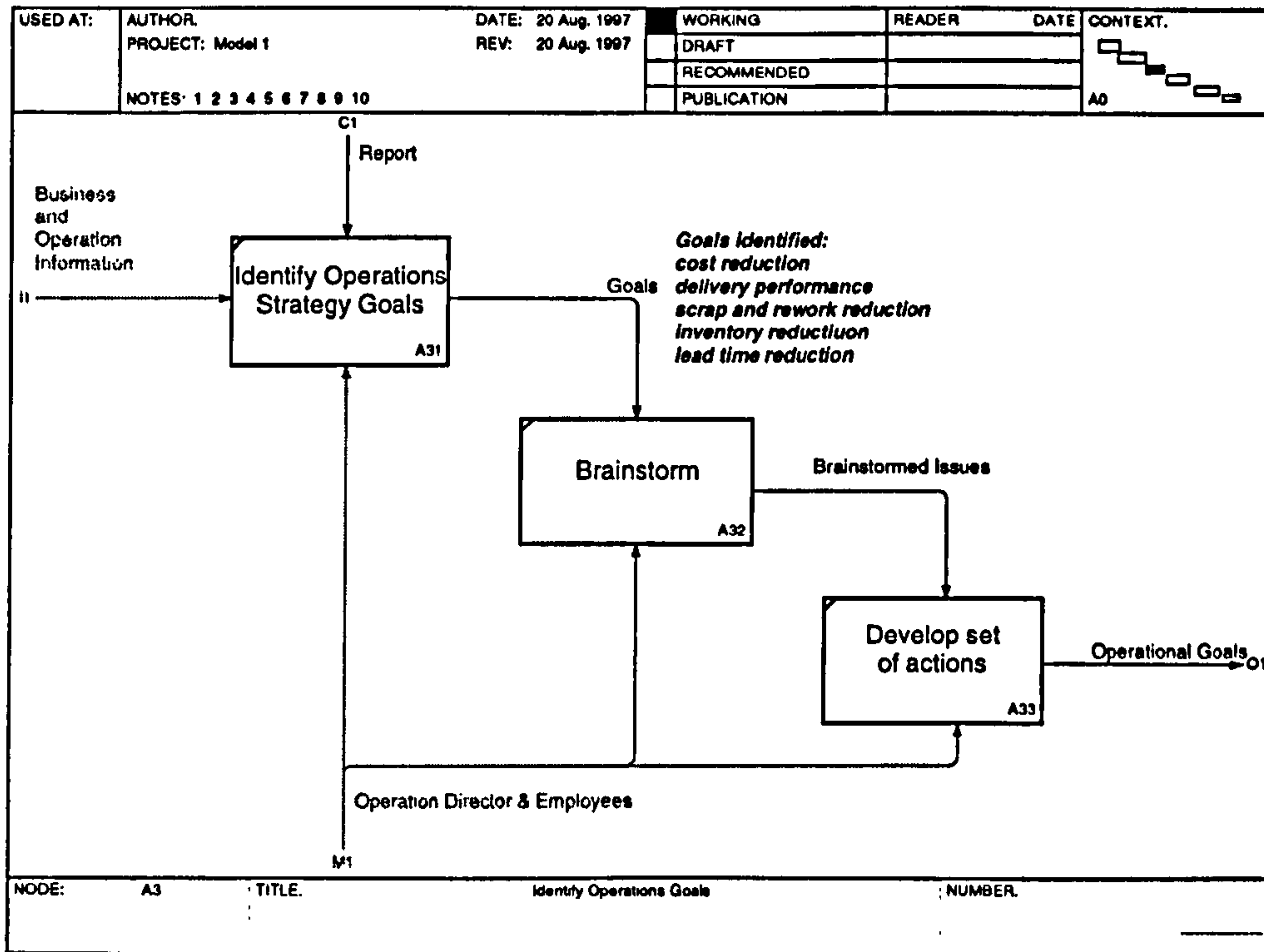

1.1. Case Study G

The data collection was carried out using interviews, company documents and the Internet in June 1996.

1.1.1. Type of Case

Systems and Components Supplier.

1.1.2. Participants

Manufacturing Director.

1.1.3. Source of data

Interviews, Company Documents, Individual Study, The Internet.

1.1.4. Validation

The data gathered has been validated and updated through correspondence with the Manufacturing Director. The workbook developed in chapter 9 has been sent to the organisation for comment.

1.2. General Background

Case G is a world leader in aerospace electronics, medical systems and specialised industrial products. With a commitment to research and development, investment in advanced manufacturing and closely focused marketing, the Company has maintained a strong record of progress through organic growth and acquisition. Almost three quarters of Case G's sales are generated outside the United Kingdom, with the United States as its largest single market. The Company consists of three groups, operating in clearly defined sectors: medical systems, specialised industrial products and aerospace electronics.

The Aerospace sector is an international group of companies supplying high technology equipment for the world's aerospace and defence markets. The group employs some 5000 personnel at nine manufacturing sites - five in the UK and four in the USA. Together, these sites specialise in the development, production and marketing of advanced electronic instrumentation and systems for civil and military aircraft, naval and marine applications and land-based fighting vehicles.

The group is divided into five operating divisions.

- Civil Systems
- Defence Systems
- Engine & Fuel Systems
- Naval & Marine Systems
- Product Support

1.2.1. Position in Supply Chain

Case G can be described as a Systems and Components Supplier within the UK aerospace supply chain and also in international markets.

1.3. Case G - The Manufacturing Organisation

Case G is a leading manufacturer of advanced electronic equipment and systems for the international defence industry, and plays a vital role in military programmes such as the F-22, Eurofighter 2000, EH101, AV-8B, Longbow Apache and the M1A2 Abrams Main Battle Tank. The Defence Systems division's main product areas cover diverse technologies and wide ranging applications. Currently these include

- Nav/attack systems,
- Data management systems,
- Reference systems
- Display systems,
- Flight control systems,
- Stores management systems,
- Utilities and power management systems,
- Engine diagnostic systems,
- Vehicle navigation systems and vehicle management systems.

1.4. Process of Manufacturing Strategy Formulation

1.4.1. General Strategy

Competition within the Aerospace Industry is cut throat with suppliers having to give guaranteed cost reductions of 5 % each year over 5 years. This has led to the formulation of multi Company teams to reduce costs - putting the onus on the supplier for cost savings. The current strategic objectives of Case G are to be the market leader on Power Management Systems. The organisations reputation was based on high quality and high cost - now it is fitness for purpose.

The Manufacturing Strategy has a major input into the top level strategy. Targets are flowed down the organisation together with appropriate performance measures. The performance measures are not linked to pay. With the movement towards cellular manufacture and team working, team objectives are set within the cells.

Manufacturing Strategy plan is set for 5 years - it is known at the bid stage if any major investment or change is required.

Process

1. Marketing plan - reviewed continually - published annually
2. Process mapping - to determine what must be done to achieve the objectives derived from the strategy
3. Forecast of Production - 5 years
4. Plot sales over 10 years
5. Plan investments for Engineering and Production
6. Determine Manufacturing objectives

Performance Measures: It is a requirement to achieve different levels of achievement against certain non financial performance measures. These measures focus on reducing *lead times, cost and stock levels*.

1.4.2. Point of Entry

Benchmarking clubs have been set up by Lucas and SBAC. A great enabler for change is also the preferred supplier schemes run by Prime Contractors within the Aerospace Industry.

1.4.3. Participation

- Assembly Manager
- Manufacturing Engineering Exec
- Material Exec
- Manufacturing Director

also looked at by other members of the board- to see if the strategy agrees with the corporate objectives

1.4.4. Project Management and Timescales

The process is triggered by the change in corporate of business strategy and the launch of a new bid.

1.4.5. Hayes and Wheelwright Four Stage Model

Case G appears to be at stage 3.

1.4.6. Objectives

Long term

- become an *assembly* and *test* organisation only
- treble the business in 10 years

Short term

- Lead Time reduction
- Stock reduction
- Cost reduction
- Time compression
- Lean production

Time compression - breakdown of facets, time based process mapping, time added value - queuing time, waiting time, rework time

Order winners and qualifiers

- cost - fundamental criteria
- ability to support the product - supportability - FRACAS
- quality
- competence - credibility

1.4.7. Decision Areas

The following decision areas are important in the formulation of Case G's Manufacturing Strategy.

Suppliers

A 4 tier supply chain exists. It is necessary to be able to reduce costs without having to reduce profit. The aerospace industry is moving towards partnerships and open book accounting. I.e. US customers as well as the MoD are able to audit everything. Cost audits are carried out on development and factory work. Accepted levels of profit are agreed between the customer and supplier. Case G want to reduce the number of suppliers and increase the amount of work given to these suppliers [PCB manufacturers merging].

Process Choice:

It is not economical to manufacture small quantities

Core Competencies:

Assembly and test - want to make this the core competence - do not want to manufacture components in house

Process or Functionally based organisation:

Definitely a move towards a process culture - still have a figure head function - but will be mostly processually based - will take time - but this will happen.

Innovation within Manufacturing:

- indirectly - Teams and Continuous Improvement
- used to have a suggestion scheme - do not have them anymore - not mutually conducive to having people working in teams
- resource committed
- site bonus scheme - everyone gets a bonus if the targets are exceeded.
- Motivation - has been job security most recently, now variation and the ability to see a career path.

Computer Aided Production Management:

Conventionally manufacturing was broken up into generic product groups, with separate areas for production control and engineering. Now have a fully integrated Manufacturing Resource Planning programme which included finance.

This is a requirement of North American customers which make up 50 - 60% of the customer base. It is a contractual requirement to be able to track the project. I.e. material must be designated as it is purchased. Allowing stage payments and clear visibility for the customer regarding spend.

1.4.8. Make or Buy Philosophy

Based on core business

1.4.9. Emergent or Planned - the Process

The process of Manufacturing Strategy Formulation appears to be a hybrid of emergent and planned.

1.5. Cultural Issues impacting on Manufacturing Strategy

- changed dramatically - used to be a closed book but have adopted an open, frank culture/
- Have good communication - good and bad news are communicated straight away
- Developed regular communication at all levels - to get rid of rumour control - monthly team briefings
- open door approach - staff council - helps to resolve problems
- appeals procedure
- closed shop manual union - good communication

Human issues

- people are becoming multi disciplined
- people are trained on financial awareness and quality aspects - ISO 9000
- team work has broadened peoples job span
- continuous improvement teams - when failures are discovered the cause are analysed.
- aim to reduce lead times, stock reduction

1.6. Change Programmes resulting from the Manufacturing Strategy

1.6.1. Effects of major Customers on strategy and change programmes - Preferred Supplier Programmes

Major customers - Westlands, McDonnell Douglas, BAe have initiated preferred supplier schemes which have given companies such as D a sharp focus for improvement. This is now becoming the format for the aerospace industry.

The preferred supplier auditors from prime contractors look at several aspects of the business. Customers have their own schedule - main drivers and ask how the organisation is structured and managed using the following modules

- Management Business Assessment - looks at the business as a process, looks at the strategy and bid process
- Quality - includes Statistical Process Control [SPC][equates to supplier performance]
- Delivery - The ability to provide goods within a certain time frame window[equates to the order fulfillment process]
- Engineering and Technology - [how to measure metrics within engineering and how to improve the process]

1.6.2. Cellular Manufacturing

The decision was taken to move to cellular manufacturing to achieve the above objectives. This was due partly to a benchmarking exercise carried out in conjunction with the DTI and SBAC. The development of multi functional teams was also important in achieving the above [members of the Cell Club which enables organisations to learn from each other - set up by Lucas]

3 cells are planned following the results of the PCB assembly and test cell - this is the pilot for the rest of the site. The other 2 cells are planned for the HUD and Power Management [electro-mechanical].

1.6.2.1.The pilot - PCB Assembly and Test cell

This is the pilot cell for 12 months beginning on the 5th of August 1996. The cell will be self standing with its own overhead rates and responsibility for cost reductions and manufacturing all products on time. The cell will have dedicated Quality, Industrial and Test engineers. Cell members will have control of all expediting - may purchase and expedite their own goods. However may not arrange their own supply agreements.

Key points for pilot

- Purchasing will only pull of agreements that have been made already.
- Training for the pilot cell - 6 months were spent training the cell manager
- The Process cell will not actually sell anything - pass on products to other cell to sell £50 million worth of business between the two of them.
- Factory output - the cell puts a mark-up on the output and the products
- totally flat organisational structure
- for the pilot - cell manager will be both a co-ordinator and the cell champion. More training on team working is planned over the next 6 months

1.6.2.2.Implementation of cells - the process

1. Map the 'As-Is' process
 2. Brainstormed the possibilities for potential gain
 3. It became clear that the value added within the process was quite low,
 4. The significant area was the lying out of the track
 5. 44% of the process was value added
 6. Used the same people to change it
- facilitated by Warwick University - used to look at lead time reduction and manufacturing processes..

1.7. Relevant Systems

The Manufacturing Strategy Formulation Process has been identified as the relevant system.

1.8. Emergent Manufacturing Strategy Archetypes

The emergent archetype is appears to be the World Class Manufacturing model.

1.9. The Root Definition

A system to: produce a manufacturing strategy *by means of:* analysing manufacturing and business data *in order to:* support changes in corporate strategy

- Customers:** • Corporate
- Actors:** • Operations Team
- Transformation:** • Manufacturing and business information into a change programme
- Worldview:** • Business planning - manufacturing supports the corporate strategy
- Owner:** • Manufacturing Director
- Environment:** • Global and European markets

1.10. IDEFo Models of the relevant system.

1.10.1. Manufacturing Strategy Formulation Process

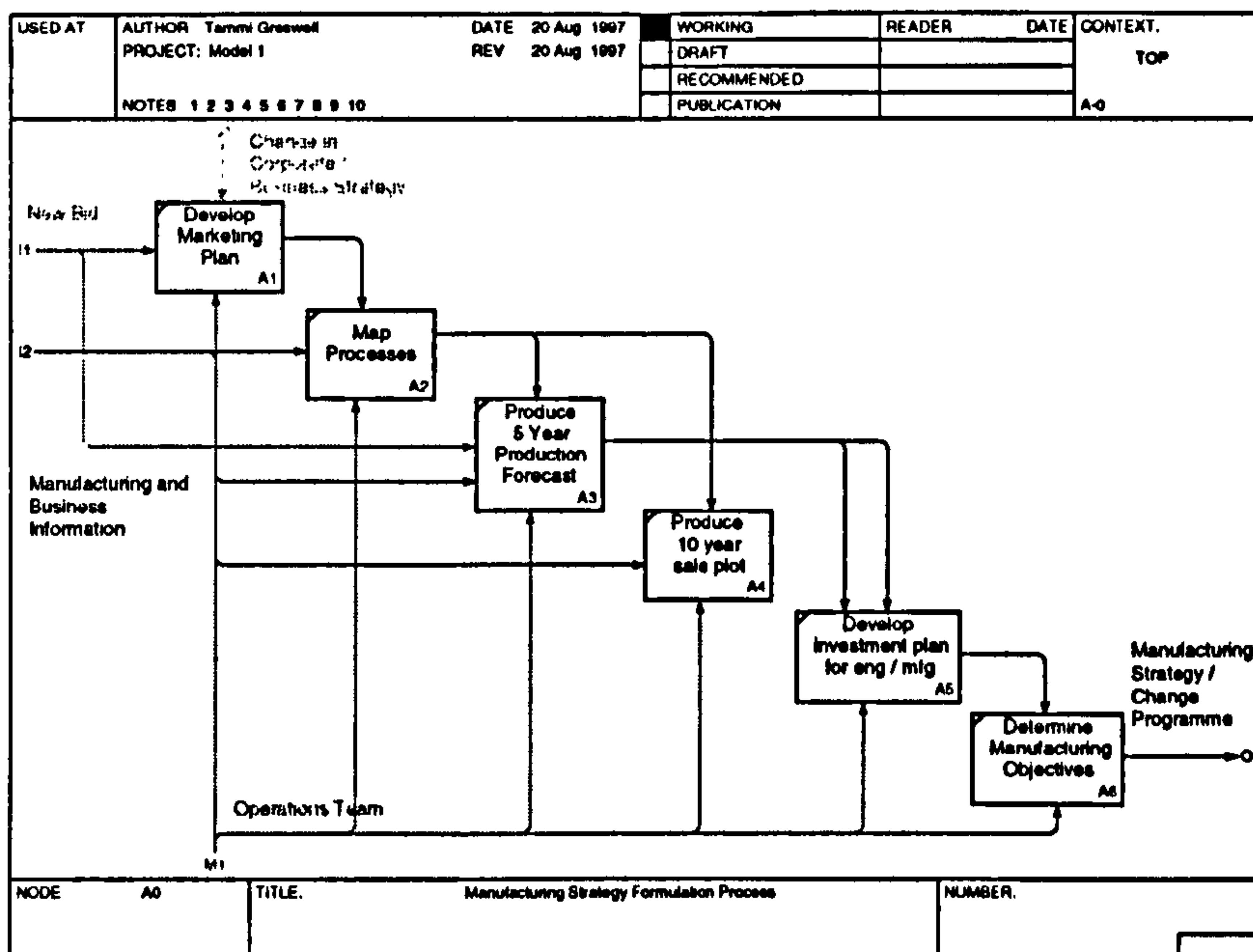

1.1. Case Study H

The data collection was carried out using interviews, company documents and the Internet in June 1996.

1.1.1. Type of Case

Components Supplier.

1.1.2. Participants

Manufacturing Director.

1.1.3. Source of data

Interviews, Company Documents, Individual Study.

1.1.4. Validation

The transcript of the interview was sent back to the interviewee for comments.

1.2. General Background

Case H is an American Company based around General Engineering including Aerospace, Oil, Textiles, Nuclear and Printing. The division analysed in this case study consisted of the Coating Services Business. The organisation is based around providing customers with an excellent service.

- Gulf War had a good effect on the business
- 92' business started to slow down dramatically
- 95' business started to pick in the last quarter of last year

The organisation is involved in a rapidly fluctuating business. Sales were in decline at the beginning of 1992 due to the lack of confidence in the aerospace and oil industry. The effect being a reduction in staff by 30%.

The organisation was restructured with several positions merging such as planing and quality engineering. Several layers of management were removed with people given more responsibility and authority. 7 production group leaders used to be responsible for each market sector, this has changed to 3 building managers covering all sectors. The product mix was rationalised and down times minimised due to the customers wanting price reductions. The situation is now improving with new orders going in for both civil and military contracts. The Aerospace sector contributes 44% of turnover at the Swindon site, about 60% overall.

1.2.1. Position in Supply Chain

Case H can be described as a Components Supplier within the UK aerospace supply chain and also in international markets.

1.3. Case H - The Manufacturing Organisation

The overall strategy was described as: *Good service, good quality and right price* with the aim of growing the business every year. It was affirmed that it is important to know where the business is and which direction it is going in. Investments and capital investments are discussed.

1.4. Process of Manufacturing Strategy Formulation

1.4.1. General Strategy

The direction of the company is discussed annually. Key Performance Indicators [KPI] are agreed between the manufacturing director and the general manager. These measures of performance cover:

- Delivery
- Cost of Quality [rework costs]
- Health & Safety
- Zero Working Capital
- Sales
- Profit

The stretch goals which have been put in place are: 100% delivery performance and 0% defects. The strategies are driven by sales figures and projected workload. Budget plan - manpower requirement, controls all the costs - some activities are subcontracted.

Performance Measures

Measures of performance are agreed with senior Management and filtered through out the organisation. A Presentation is given to the whole plant, discussions are held with the supervisors to decide how to implement.

The following are currently measured:

- business performance results
- cells analysis and plant analysis
- cost analysis
- profit margin by cell
- cost of rework

Costs and delivery performance are not made visible to all employees.

1.4.2. Point of Entry

The trigger for the change in operations came from the fluctuations of the market. This was the enabler for the changes that took place within operations. It became clear that the move towards a world class manufacturing ethos together with quality was right operations.

1.4.3. Participation

Sales and marketing team - operations and sales work closely together

1.4.4. Project Management and Timescales

The business is analysed once a year to determine if the current strategies are still valid and if any changes need to be made. Projected plans have been drawn up to the year 2000.

1.4.5. Hayes and Wheelwright Four Stage Model

Case H appears to be at stage 2.

1.4.6. Objectives

Long Term

- World Class Manufacturing and Quality. Take on parts of businesses to give the customer a complete package. Vertical integration

Short Term

- Simplicity by set up reduction, multi functional quality improvement teams

Order winners and Qualifiers for the aerospace sector

- Quality
- Delivery
- Price
- Technical Support

1.4.7. Decision Areas

1.4.7.1. Corporate Learning

Management style - good leadership, are empowered to make own decisions. The style has changed from being 'harsh with little support'.

1.4.7.2. Quality

The Total Quality Programme was launched in 1989 by the chairman of the parent organisation, who outlined the programme and the TQM strategy. All senior managers were trained as facilitators and this was then fed throughout the organisation. This was followed by 2 years of training.

The following methods are used within operations:

- Statistical Process Control,
- Inspection Procedures,
- Quality Circles
- Preventative Maintenance
- Due to the arrangement of the cells, most production tends to be batch production.

1.4.7.3. Core Processes

Operate Business Processes

Parts come in from the customer to be coated and ground.

T cards are used within each cell to plan the schedule within that cell. T cards are annotated with job number and customer.

1.4.7.4. Core Competencies

Core competence - applying engineering to customers products

People are *the* core competence. The technical core competencies include the following

- Scanning electron microscope
- Profiling
- grinding
- Coating
- NDT

1.4.7.5. Process or Functionally based organisation

Predominantly a functional organisation.

1.4.7.6. Innovation within manufacturing

No suggestion schemes on site. Employees are encouraged to be proactive and are rewarded if they have a good appraisal. [suggestion schemes are difficult to manage]

1.4.7.7. Technology Development

Technology - based in Indianapolis - focus on the development of the following:

- processes
- coating applications
- work on specific problems
- world wide support service
- new equipment

1.4.7.8. Computer Aided Production Management

Planning tools - have not found any suitable ones as yet

1.4.8. Make or Buy Philosophy

Central purchasing department for 3 sites - customers give them awards for good performance.

1.4.9. Emergent or Planned - the Process

The Manufacturing Strategy Formulation Process tends to be a planned process as opposed to emergent.

1.5. Cultural Issues impacting on Manufacturing Strategy

- high quality people
- flexible
- very company orientated
- investing lots of money in automation
- want to be perceived as being the best
- still some fear about security
- professional company

Human Issues

Employee involvement - all have PDP's which take them to a certain level, visit customers, solve technical problems with customers, are authorised to purchase all materiel required to do the job

1.6. Change Programmes resulting from the Manufacturing Strategy

1.6.1. Cellular Manufacturing

The move towards Cellular Manufacturing is part of the strategic move towards World Class Manufacturing. The cells have been developed to allow total flexibility between cells plants and building. All cells have identical equipment with a multi skilled team. Specialists are also on hand for the supporting role.

The cells have been divided as follows:

- special materials
- multi cell
- oil cell
- aerospace cell
- textile cell
- carbide cell

This has allowed the individual cells to focus on these products and customers, allowing the teams to get to know the product and customer inside out.

Quality
Customer engineers
Operations and planning

all contained within the cell

1.7. Relevant Systems

Manufacturing Strategy Formulation Process

1.8. Emergent Manufacturing Strategy Archetypes

World Class Manufacturing

1.9. The Root Definition

A system to: develop a manufacturing strategy *by means of*: analysing the current business, identifying key performance indicators and determining stretch goals *in order to*: meet the manufacturing operating plan.

- Customers: • Manufacturing organisation
- Actors: • Manufacturing Director and Team
- Trans - formation: • Manufacturing and Business data into the Manufacturing operating plan
- Worldview: • Planning based on sales and projected workload
- Owner: • Manufacturing Director
- Environment: • Multiple Industry

1.10. IDEFo Models of the relevant system.

1.10.1. Manufacturing Strategy Formulation Process

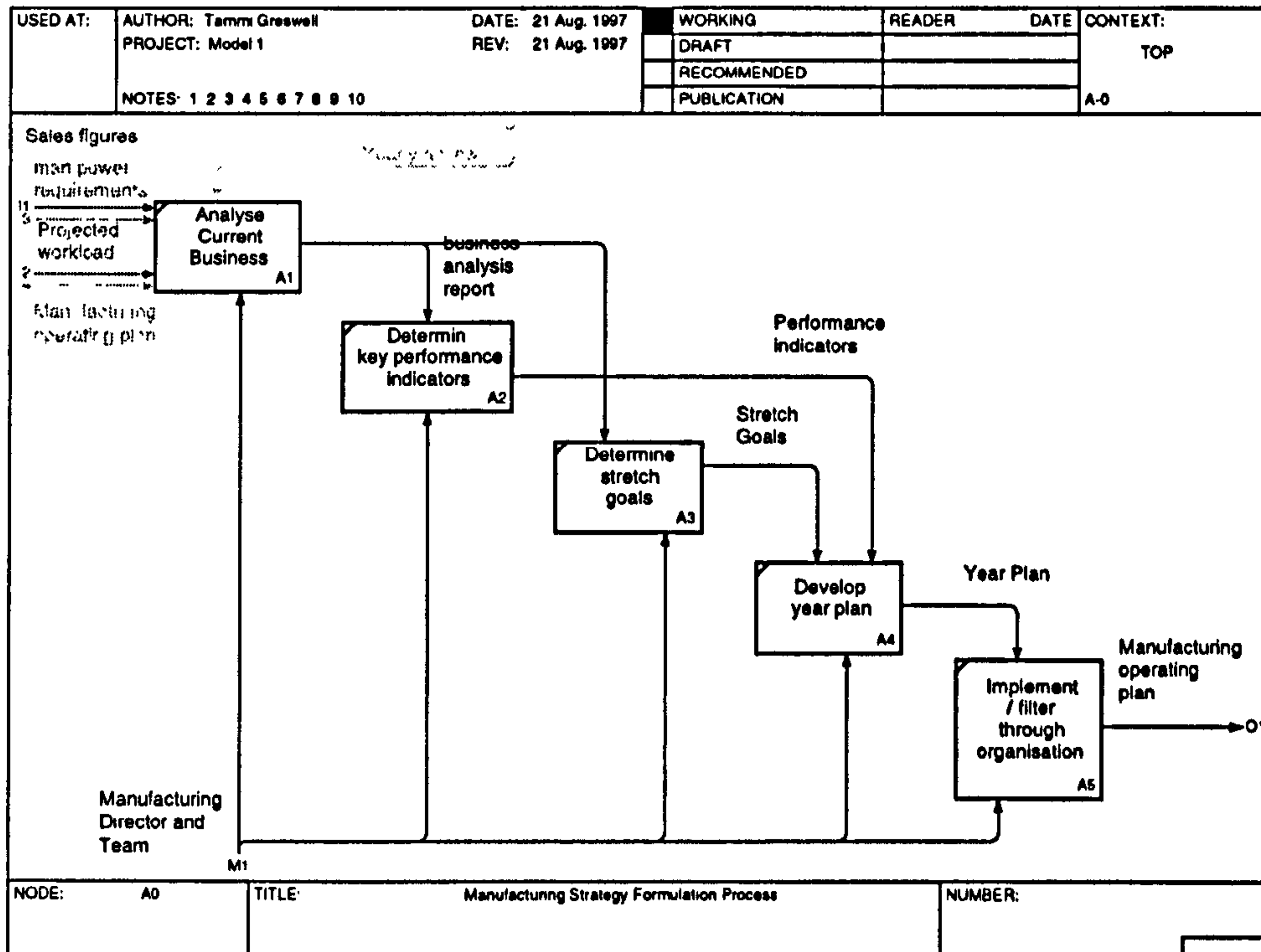

1.1. Case I

The collection of data has been carried out from a six month placement at the organisation. Data was gathered from workshops, meetings, interviews and company documents between October 1997 – April 1998.

1.1.1. Type of Case

Prime Contractor, Systems Supplier

1.1.2. Participants

Manufacturing development personnel
Manufacturing engineering managers
Manufacturing engineers
Training partners
Head of manufacturing processes

1.1.3. Source of data

Empirical research - open ended interview with management. Workshops with managers, one to one interview, meetings, action research as the process developer for the effective manufacturing engineering process.

1.1.4. Validation

The data was validated by three sources within the organisation and through several workshops.

1.2. General Background

The company is a large aerospace prime contractor which has gone through an immense amount of change in the past decade. This case study is built around the six months from Oct 97 to April 98. The company operates within a global market with multiple sites and multiple projects and products. The case study is built around the experiences of the core engineering function and the processes developed within the function for manufacturing strategy formulation and manufacturing engineering strategy formulation.

The organisation has embarked on a programme called 'Project Axis' which has changed the organisational structure to one which has a project focus, a process focus and a discipline focus. The programme is seen as an enabler for OEI which is mentioned in case I. OEI aims to deliver superior performance by reducing lead times, costs and to provide adherence to schedules in a 20 – 30 – 100 ratio. The company has had to change due to the following factors:

- Cost plus legacy
- An organisation which was neither functional or project
- Fuzzy boundaries
- Responsibilities and accountabilities not matched
- Duplication

The vision which has forced the change has been verbalised as:

- Effective customer responsive organisation
- Integrated multifunctional teams with common goals
- Clear roles, responsibilities and accountabilities
- Strong internal customer / supplier based relationships
- Clear project focus supported by functional excellence

- Freedom to act

The business has been split into three areas, internal supply, customer programmes and others. Internal supply incorporates manufacturing, technical and supply support, customer programmes are the customer facing elements of the value chain and the 'others' include the functions which look after the discipline interests e.g. manufacturing engineering, enterprise planning and strategic management

The relationship between the projects and the functions is crucial to the success of the reorganisation. The function is responsible for creating, improving and maintaining process excellence, providing functional people for the projects, maintaining discipline excellence and benchmarking their people and processes against best in class. The projects interface with the customer, manages the team, identifies resource demand, operates defined processes, has financial accountability and is measured against quality, cost and delivery.

1.2.1. Position in Supply Chain

Prime Contractor, systems integrator and systems supplier. 80% of materiel is bought out.

1.3. Process of Manufacturing Strategy Formulation

1.3.1. General Manufacturing Strategy Process

The manufacturing strategy formulation process is an outcome from the following:

The overall Case I strategy which identifies which business the organisation is in, the core values, delivers the operational value plan and identifies the business excellence model as a framework to develop the business towards world class. This feeds into the technical research and development strategy which delivers the research and development operating principles, identifies the current technology capabilities, places the current technology capabilities within a benchmarking framework, identifies the strategic value of each technology capability and carries out risk and maturity analysis.

The manufacturing strategy process identifies site tiers according to core competencies, by developing a profile analysis, and carrying out competence and strategic sourcing analysis, this delivers a skill capability by function and by cell. Due to the data being proprietary more explanation is not available.

The work carried out by the author involved developing the effective manufacturing engineering process which forms part of the manufacturing strategy. The process provides the people and process excellence required by the projects for the manufacturing operations and is based around the business excellence model.

1.3.2. Point of Entry

The point of entry for the organisation was the realisation that due to major changes in the market, the operating effectiveness and efficiency of the organisation needed radical improvement.

1.3.3. Participation

Hayes and Wheelwright Four Stage Model
Case I appears to be between stage 3 and 4

1.3.4. Objectives

The objective of the effective manufacturing engineering process was 'a process to ensure manufacturing engineering has the relevant process and technology capabilities and people competencies to support the business in all parts of the project life cycle'

Action plan to deliver the capabilities identified
Mechanism for sharing best practice

1.5. Relevant Systems

1.5.1. Emergent Manufacturing Strategy Archetypes

World Class Manufacturing and Learning Organisation

1.5.1.1. The Root Definition

A system to: ensure manufacturing engineering has the relevant process and technology capabilities and people competencies by means of: the effective manufacturing engineering process in order to provide people and process excellence to the project both internal supply and the customer programmes

- | | |
|-------------------------------|--|
| Customers: | <ul style="list-style-type: none">• Manufacturing organisation |
| Actors: | <ul style="list-style-type: none">• Product Executive, Manufacturing Director, Business Development Director |
| Trans -
formation: | <ul style="list-style-type: none">• The business plan and best practice data into change management activities |
| Worldview: | <ul style="list-style-type: none">• Best practice approach |
| Owner: | <ul style="list-style-type: none">• Various |
| Environment: | <ul style="list-style-type: none">• Global and European markets |

2. Results of Manufacturing engineering workshop 22nd April 1998

Attendees

C Mcbeth Jones, C Jarmann, S Barker, K Fowler, T Greswell

2.1. Definitions for each phase of the business cycle

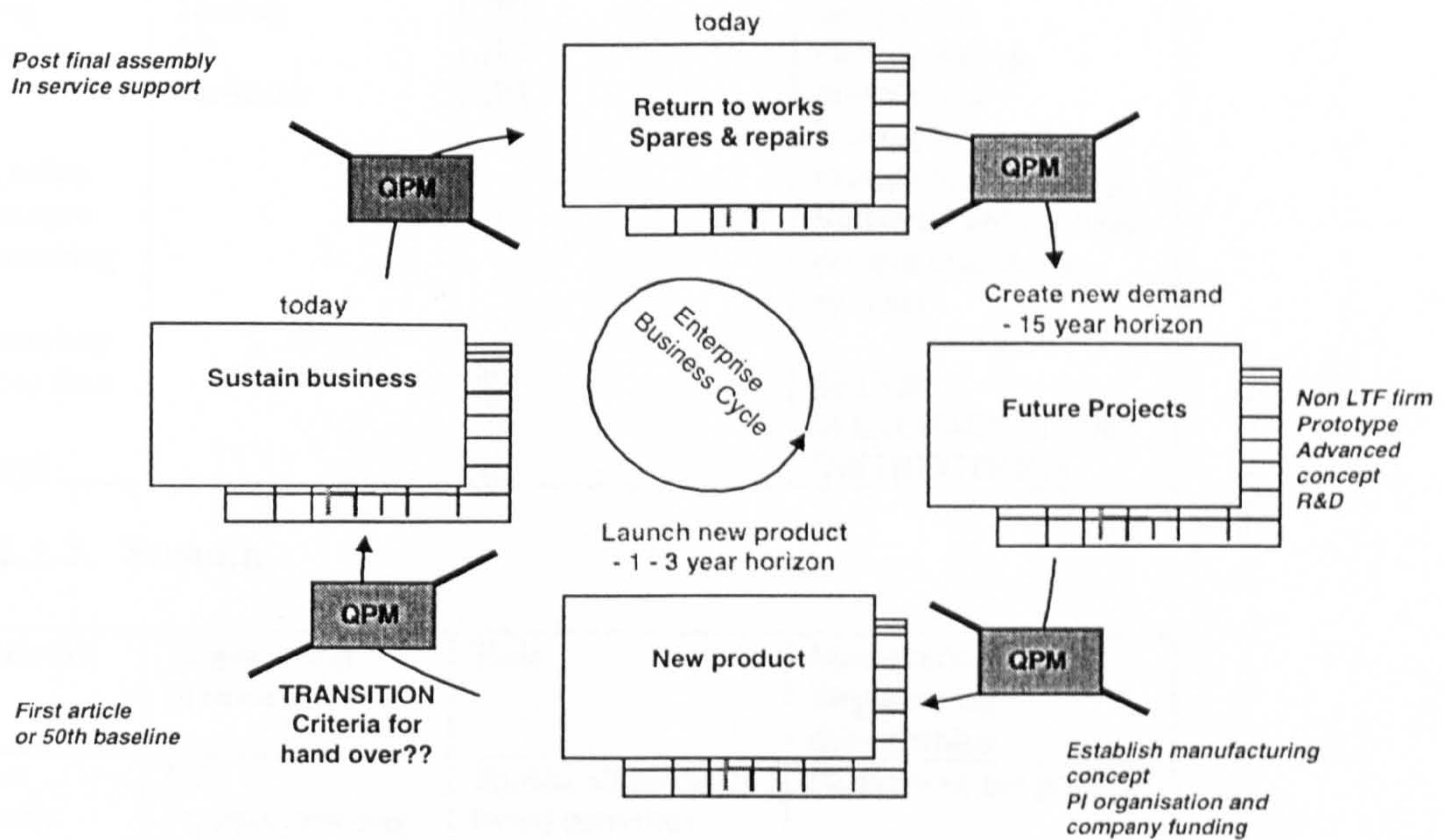

4 Project archetypes for the business cycle

- Each having a version of the practice and performance matrix
- Position and drivers will be different for each stage in the business cycle
- Develop rules around each class of business - a statement of where each project should be

Figure k2

2.1.1. Future Projects

Characteristics	Engineering processes	Role	Manufacturing Engineering deliverables
Concept DFM New process and technology	NC Process planning Tooling QE Facilities	P D E Challenge the design Design using manufacturing engineering knowledge	Manufacturing philosophy identified, assessed and developed Manufacturing strategy developed Engineering philosophy developed

			Establish manufacturing requirements
--	--	--	--------------------------------------

2.1.2. Launch new business

Characteristics	Engineering processes	Role	Manufacturing Engineering deliverables
Design for manufacture Developing manufacturing routes Facility implementation Implementation of manufacturing strategy Make versus buy Engineering data pack development	NC Process planning Tooling QE Facilities	IPT IPT IPT IPT IPT	Produceability Interpretation of the design into manufacturing instructions Testing for manufacturing ability Verifying and creating the manufacturing systems SET OF MANUFACTURING INSTRUCTIONS

2.1.3. Sustain

Characteristics	Engineering processes	Role	Manufacturing Engineering deliverables
Continuous improvement Customer change	NC Process planning Tooling QE Facilities	Should all be cell based activities	Delivery of the product

2.1.4. Support and repairs

Characteristics	Engineering processes	Role	Manufacturing Engineering deliverables
Modifications Return to works - scheduled	NC Process planning Tooling QE Facilities	Product Development Engineers	Sub contract Liaison

1.1. Case Study J

The collection of data has been carried out using a series of interviews, and company documents from one visit in June 1996.

1.1.1. Type of Case

Prime Contractor

1.1.2. Participants

Director Product Operations

1.1.3. Source of data

Empirical research - open ended interview with senior management. Literature review - Internet, journals for background, company accounts, Public Relations material

1.1.4. Validation

The initial write up was validated by the director and changed accordingly. The SSM workbook has been sent for validation, at time of writing no reply has been received.

1.2. General Background

1.2.1. Position in Supply Chain

Prime Contractor

1.3. Process of Manufacturing Strategy Formulation

1.3.1. General Manufacturing Strategy Process

The manufacturing strategy tends to be emergent in nature as a result of several stimuli listed below. No formal method for the development of a manufacturing strategy has been identified.

- Best practice
- Japanese Manufacturing methods
- Lean Manufacturing
- Cell Manufacturing
- Principles of team working
- Benchmark initiative
- Changes to the corporate infrastructure
- Partnerships
- Process focus

A planning framework is in place and is reviewed and changed [if required] annually, this is being replaced by the value plan which is a corporate wide initiative.

A formal meeting is held to launch the strategy plan, which is then discussed with the important aspects identified. People are then invited to develop the plan and to build on current strengths. Timescale based frame. - the underlying processes are fluid and dynamic.

The core values are:

Customers

- highest priority

<i>People</i>	● greatest strength
<i>Innovation and Technology</i>	● competitive edge
<i>partnerships</i>	● future
<i>Performance</i>	● key to winning

A small plastic card has been given to all staff.

The development of the manufacturing strategy can be closely related to the management style of the organisation. The management style is working towards 'buy in' and consensus within the organisation and has a profound affect on pushing accountability down through the organisation. Communication was described as being very important - talking and listening.

1.3.2. Point of Entry

Change in the civil aerospace market - saturation of aerospace manufacturing organisations. Rationalisation required to ensure the organisation remain competitive. Early 1991 was described as the point of entry breakthrough. Coopers and Lybrand were brought in as an outside intervention. Feb 1991 - Appointment of a new engineering and manufacturing director. Use of a consultancy firm as the external intervention.

1.3.3. Participation

The organisation is heavily weighted towards product groups as opposed to functions and the decision to structure the organisation into these derivative product groups has worked well. The following roles are involved in strategy formulation:

- Product Executive
- Manufacturing Director
- Business Development Director

[these roles are summarised below]

It is important to note that the functional directors have the same weighting as the product executives - but are seen as the resource owners rather than the owners of a process

1.3.3.1. Product Executives Role

The role of the Product Executive is to manage and run the design, engineering and manufacturing activity and has responsibility for the PRODUCT. Sits on the management committee of the business.

1.3.3.2. Manufacturing Directors Role

The key role of the manufacturing director is to develop resources and technologies. To provide the products group with appropriate resources as and when they are needed. The role has no accountability for product delivery, but is recognised as the resource and technology owner.

1.3.3.3. Business Development Directors [BDD] Role

Project manager reports to the BDD on the early stages of the life cycle. The issues concerning when to move people when the project moves on needs to be addressed. Different skills may be needed at different times

1.3.4. Hayes and Wheelwright Four Stage Model

Case J appears to be at stage 3

1.3.5. Objectives

to improve cash forecasts by £1 billion by 1998 - profit forecasts are described as acceptable. The aim is to make the performance of the organisation look acceptable and improve the share price.

1.3.6. Decision Areas

The decision areas which make up the content of the manufacturing strategy consist of the balancing of people processes and structure in a way that will improve share holder value.

1.3.6.1. People

Need to manage resources - with increasingly competent people - internal and external resources to meet the requirements of the business. The functions will be the bases for skills and competence development. need to keep up with peoples aspirations. a change in the remuneration system is required to eliminate grades.

1.3.6.2. Processes

3 Core Processes have been identified:

- New Product Development
- Continuous Product Development
- Derivative Products

The life cycle of the product under discussion from concept to last aircraft coming out of service can be as much as 50 years.

No specific change management process has been identified.

1.3.6.3. Structure

Product orientated management structure - reducing the number of levels of the organisation - it is still a matrix - however a matrix structure gives people the wrong idea - 70's practices tended to fail to recognise that you had to choose at the nodes who had the most power. The strength is focused in the product axis!!!

It is fundamental that the functions remain - need them to keep competency levels high - skills background to develop the people and to provide technical consultancy.

Hierarchy

Product Director
Product Executive
Project manager
Project Leaders
Team leaders

1.3.7. Other decision areas - Facilities

3 major technical buildings - arrange the buildings so that the major skill groups are arranged close to the product core group - Chrysler model

Multi site

1.3.8. Emergent or Planned - the Process

The process appears to be emergent.

1.4. Change Programmes resulting from the Manufacturing Strategy over the past 18 months

The difficulty in managing the complexity of non recurring activities has been identified as a major opportunity for change. Significant changes, examined roles and processes.

1.4.1. Continuous Product Development [CPD]

Previous situation - the modification process in engineering had several problems, there was no clearly described process and no real owner 'the baton was passed all the time'.

The change - the traditional method of mapping the 'AS IS' process was not done - believed that this would take too much time with little benefit. There would be too much detail to digest.

A decision was taken to become process orientated towards the product rather than the function.. Product Executive were appointed with full accountability for the delivery of the product. It was recognised that the main drivers at this time were the reduction of timescales and cost to satisfy the main stakeholder - shareholders to increase profit. The process owners had to develop the new processes 'on the fly'. The result of the change is that the modification process now is clearly controlled, governed and measured.

- created a best practice guide
- process framework
- checklists
- list of guidelines and issues

1.5. Current change programmes impacting on manufacturing

1.5.1. Process Focused Organisation

Focused accountability and teamworking. Natural groups were formed which are broken up and created continuously. [Problems with designing office layouts and movement of personnel] . This was a crucial component in the breakdown of functions into process teams as was the general education programme.

1.5.1.1. Pilot study - Product Development

A virtual team was put together as a pilot study for the product development process. The team recognised who was working on the product and who their customers were. Project leader appointed - lots of energy achieved a great deal. Sponsor group - achieved remarkable results. Drawing re-issues and overall costs were dramatically improved. 50% under estimated costs. A business Development Director has been appointed to oversee funding and partnerships

1.5.2. Learning Organisation - Benchmark Initiative

As a corporation, very little learning took place due to the barriers between individual companies and functions within those companies. Now appears to be a central culture which is permeating throughout the organisation - good opportunity to share learning across the organisation.

The Benchmark values are being forced from executive director level to moving to a single entity model.

20 execs attended a workshop to develop the corporate vision and mission and values that would take the organisation into the next century. 120 people were brought into the next stage to look at the values

developed and to determine what it really meant for the organisation. These values are now beginning to be deployed involving a lot of people within the organisation - whole range of company values

1.5.2.1.Key points

<i>Development of people</i>	everyone will have a personal development plan
<i>Customer focus</i>	recognise what the key drivers are to satisfy people
<i>Innovative solutions</i>	champions for innovation
<i>Performance</i>	evaluate performance - develop more synergy - new business planning process
<i>Value plan</i>	developed over next couple of years - some non financial measures - businesses will look at how they can increase their value

danger - central control - not good!! Business units must be given a fair amount of autonomy.

The Benchmark Initiative - common processes, central command and control - possible problems - self preservation - must ask how functions and processes ADD VALUE.. Some attention should be paid to the downside - a lot of hype surrounding the plan 'those that get the most hype - get the least results'

1.6. Main enablers for change -

Will give accountability and authority and responsibility to the people who are doing the job – delegation. Biggest single issue - practice not just preaching - fundamental

1.6.1. Soft Systems Issues

- Softer issues - wanted to give as much weight to the softer issues as the harder issues
- Team building - held team building exercises held to enable the team to work towards a common understanding - facilitation and counselling - try to develop a high awareness of themselves as people
- Consensus environment - all about delivery and meeting customer needs - order winning criteria.

1.7. Relevant Systems

The emergent Manufacturing Strategy Process

1.8. Emergent Manufacturing Strategy Archetypes

World Class Manufacturing and Learning Organisation

1.9. The Root Definition

A system to: develop a manufacturing strategy *by means of:* analysing the business plan and best practice data *in order to:* drive change management activities

Customers:	• Manufacturing organisation
Actors:	• Product Executive, Manufacturing Director, Business Development Director
Trans - formation:	• The business plan and best practice data into change management activities
Worldview:	• Best practice approach
Owner:	• Various
Environment:	• Global and European markets

1.10. Model of the relevant system. The emergent Manufacturing Strategy Process

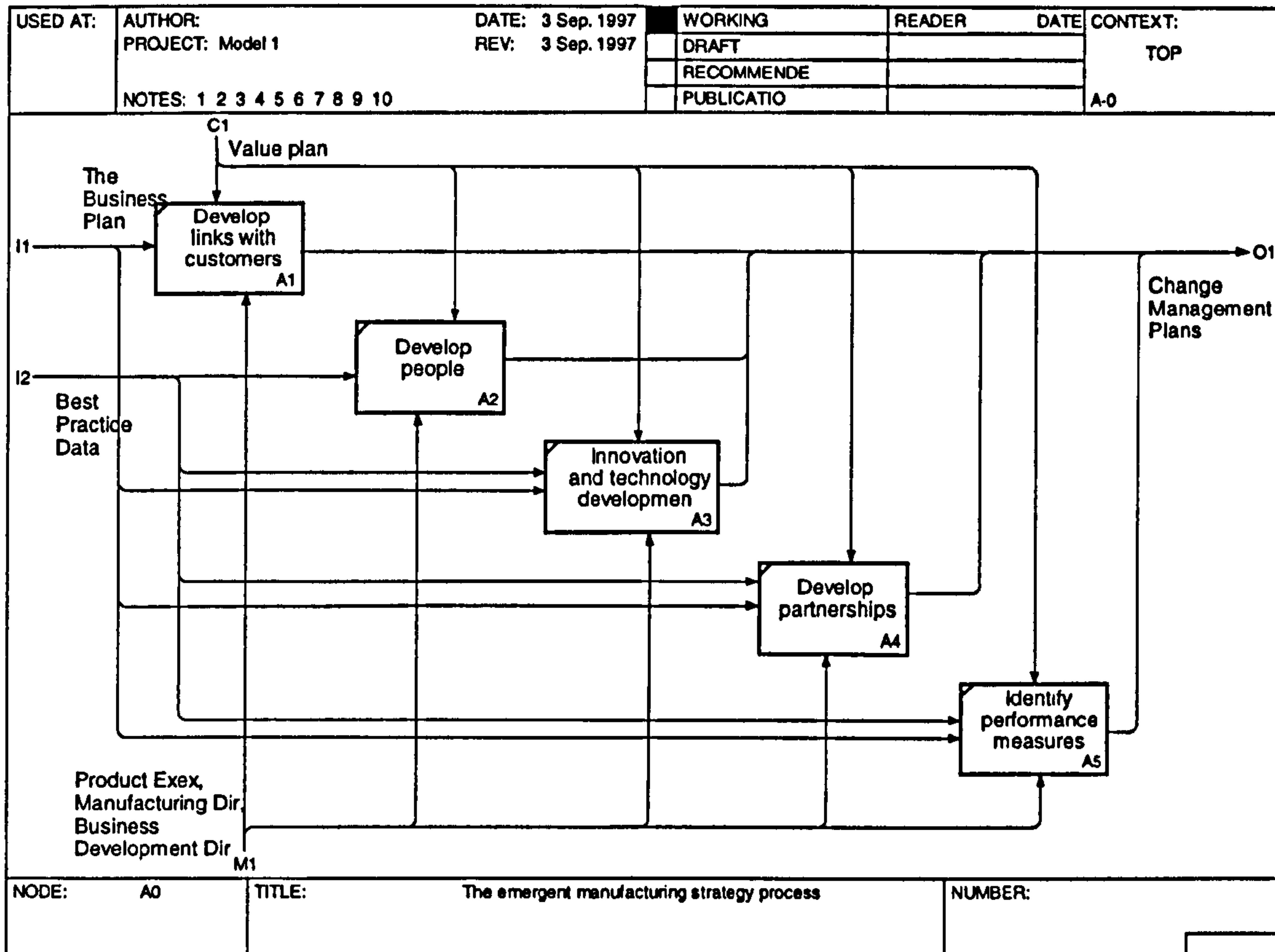

**Appendix Three – modified approach to the formulation of a
manufacturing strategy**

The workbook

BEST COPY

AVAILABLE

Variable print quality

Work book

for the Soft Systems Approach

to the formulation of a

Manufacturing Strategy

1. SECTION 1 - THE THEORETICAL BASE	4
1.1 MANUFACTURING STRATEGY	4
1.2 SOFT SYSTEMS THINKING [SST]	4
1.3 THE SOFT SYSTEMS APPROACH TO MANUFACTURING STRATEGY FORMULATION	5
1.4 BENEFITS OF USING THE APPROACH	5
1.5 ISSUES TO BE CONSIDERED WHILST FOLLOWING THE METHODOLOGY	6
2. SECTION 2 - THE SOFT SYSTEMS APPROACH TO MANUFACTURING STRATEGY	7
2.1 DOES THE ORGANISATION SEE THE NEED FOR CHANGE?	8
2.1.1 TASK 1.1 IDENTIFY MANUFACTURING STRATEGY FORMULATION PROCESS OWNER AND KEY MANUFACTURING STAKEHOLDERS WITHIN THE ORGANISATION	9
2.1.2 TASK 1.2 IDENTIFY THE CURRENT BUSINESS STRATEGY EXPLICITLY	9
2.1.3 TASK 1.3 IDENTIFY THE CURRENT PERCEPTION OF MANUFACTURING WITHIN THE ORGANISATION.	13
2.1.4 TASK 1.4 IDENTIFY AND EXPLICITLY STATE THE CURRENT MANUFACTURING STRATEGY	16
2.1.5 TASK 1.5 DEVELOP A COMPETITIVE PROFILE FOR THE ORGANISATIONS MOST IMPORTANT PRODUCT GROUP	17
2.1.6 TASK 1.6 GAIN COMMITMENT FOR THE NEXT STAGE OF THE MANUFACTURING STRATEGY FORMULATION PROCESS.	20
2.2 THE MANUFACTURING OPERATION AND ITS EFFECT ON THE COMPETITIVENESS OF THE ORGANISATION [THE REAL WORLD PROBLEM SITUATION - UNSTRUCTURED]	21
2.2.1 TASK 2.1 QUESTIONNAIRE FOR THE DEVELOPMENT OF UNDERSTANDING OF THE MANUFACTURING ORGANISATION	22
2.2.2 TASK 2.2 ASSIMILATE DATA FROM COMPLETED QUESTIONNAIRES TO GET DIFFERENT PERSPECTIVES FROM STAKEHOLDERS	27
2.2.3 TASK 2.3 DEBATE FINDINGS - REACH A GENERAL CONSENSUS ON IMPORTANT ISSUES	27
2.2.4 TASK 2.4 DEVELOPMENT OF DIAGRAMS, PICTURES TO PORTRAY THE SHARED UNDERSTANDING OF THE CURRENT MANUFACTURING OPERATION	27
2.3 THE PROBLEM SITUATION - THE DEVELOPMENT OF THE MANUFACTURING STRATEGY? <i>WHAT DO WE WANT MANUFACTURING TO ACHIEVE [HOW AND WHAT?] AND HOW DO WE WANT THE RELEVANT SYSTEMS TO SUPPORT IT?</i>	29

2.3.1 TASK 3.1 DEVELOP A STATEMENT OF WHAT THE ORGANISATION EXPECTS OF MANUFACTURING. IDENTIFY SPECIFIC STRATEGIC OBJECTIVES FOR MANUFACTURING.	30
2.3.2 DEVELOPMENT OF OBJECTIVES	36
2.3.3 TASK 3.3 IDENTIFY MANUFACTURING SYSTEMS WHICH WILL HAVE A SIGNIFICANT ROLE IN ACHIEVING OR SUPPORTING THE OBJECTIVES IDENTIFIED EARLIER.	37
2.3.4 WHAT WE HAVE ACHIEVED BY THIS STAGE	38
2.4 THE DEVELOPMENT OF THE ROOT DEFINITIONS FOR EACH RELEVANT SYSTEM SELECTED IN STAGE 3	39
2.4.1 TASK 4.1 DEVELOP ROOT DEFINITION FOR WHAT YOU WANT YOUR RELEVANT SYSTEMS TO ACHIEVE IN TERMS OF SUPPORTING THE MANUFACTURING OBJECTIVES IDENTIFIED PREVIOUSLY.	39
2.5 THE DEVELOPMENT OF CONCEPTUAL MODELS DERIVED FROM THE ROOT DEFINITIONS FROM EACH RELEVANT SYSTEM	44
2.5.1 TASK 5.1 DEVELOP CONCEPTUAL MODELS OF THE CHOSEN RELEVANT SYSTEMS USING THE ROOT DEFINITIONS AND SYSTEMS CONCEPTS DEVELOPED IN STAGE 4	44
2.6 THE COMPARISON OF THE CONCEPTUAL MODELS AND THE REAL WORLD SITUATION.	49
2.6.1 TASK 6.1 COMPLETE COMPARISON TABLES	49
2.7 IDENTIFICATION OF FEASIBLE AND DESIRABLE CHANGES TO THE MANUFACTURING STRATEGY SYSTEM - OUTPUT THE DIRECTION AND JOURNEY OF THE MANUFACTURING SYSTEM - THE MANUFACTURING STRATEGY	51
2.7.1 TASK 7.1	51
2.7.2 TASK 7.2	52
2.8 SOME NOTES FOR IMPLEMENTATION	53
3. SECTION 3 - ADDITIONAL INFORMATION	54
3.1 GLOSSARY OF TERMS [TAKEN FROM CHECKLAND 1991]	54
4. ANALYSIS OF RESULTS - FEEDBACK OF PROCESS OF MANUFACTURING STRATEGY FORMULATION PROCESS USING MODIFIED SOFT SYSTEMS METHODS.	56
5. PROCESS MODEL OF THE FLOW OF THE METHODOLOGY.	57

Introduction

Welcome to the workbook for the Soft Systems approach to the formulation of a Manufacturing Strategy. This workbook is split several sections.

Section 1 introduces the general concepts of the process of manufacturing strategy formulation, the reasoning behind using a soft systems approach, the benefits of using the approach and the issues to bear in mind when using the work book.

Section 2 sets out the approach to formulating a Manufacturing Strategy using soft systems concepts. Each stage of the approach is introduced with an objective, stage deliverables, tasks and templates to help guide you through the stage.

Section 3 contains a glossary of terms used within the approach

Section 4 provides an opportunity to feedback your experiences using the workbook

Section 5 shows the methodology as a process flow

NB The workbook is one of the deliverables of a 3 year PhD research project entitled 'A Soft Systems Approach to the Formulation of a Manufacturing Strategy' funded from a studentship from the Engineering and Physical Sciences Research Council under the guidance of Dr Steve Chittle, Dr Roger Maill and Dr Ian Bennett. The workbook is a result of research into the process of Manufacturing Strategy Formulation within the UK Aerospace Industry and is intended as to be used as a template and guide for the development of a Manufacturing Strategy. The workbook is descriptive as opposed to prescriptive and prefers to give indicators as a guide to learning as opposed to prescriptive methods which have to be followed.

If you have any comments on the usability, format, content or process of the workbook Please contact

*T J Greswell
School of Computing
University of Plymouth
Drake Circus, Plymouth
Devon, PL4 8AA, UK*

*TGRESWELL@plym.ac.uk
Tel 01752 - 232620
Fax 01752 - 232540*

*Page 3
12/09/97 15:56
Version: draft*

Section 1

1. Section 1 - The Theoretical Base

Section 1 introduces the general concepts of the process of manufacturing strategy formulation, the reasoning behind using a soft systems approach, the benefits of using the approach and the issues to bear in mind when using the work book.

1.1 Manufacturing Strategy

Manufacturing Strategy is all about constructing advantage from the manufacturing system and is a simple yet powerful concept for positioning the manufacturing process or function to support, guide and influence the competitiveness of its organisation. Manufacturing Strategy can be described using the analogy of a boat, the direction and destination of the vessel [the organisation] depends on several factors which are dynamic and to a degree unpredictable. This could include tides [customer satisfaction], rocks [legislation], the weather [emerging new technologies] and so on. The tools used to help vessels navigate could include charts, Global positioning systems, as well as the experience of the skipper and crew.

Therefore using this analogy regarding Manufacturing Strategy, the workbook should be seen as a chart to enable you to plot your journey and direction using methods derived from current Operations Management theory and tested within British Industry. Together with the stakeholders experiences within operations management, should enable the formulation of a useful and implementable Manufacturing Strategy.

A note of caution: the methodology is a guide and a framework for developing a manufacturing strategy - each organisation has its own values, beliefs and ways of working, therefore the examples shown in section 3 should not be copied but used as learning opportunities.

1.2 Soft Systems Thinking [SST]

SST has been developed as a complementary approach to typical reductionist approaches to problem solving. The approach looks at the whole system and incorporates different points of view held by the

*Page 4
12/09/97 15:56
Version: draft*

Introduction

Welcome to the workbook for the Soft Systems approach to the formulation of a Manufacturing Strategy. This workbook is split several sections.

Section 1 introduces the general concepts of the process of manufacturing strategy formulation, the reasoning behind using a soft systems approach, the benefits of using the approach and the issues to bear in mind when using the work book.

Section 2 sets out the approach to formulating a Manufacturing Strategy using soft systems concepts. Each stage of the approach is introduced with an objective, stage deliverables, tasks and templates to help guide you through the stage.

Section 3 contains a glossary of terms used within the approach

Section 4 provides an opportunity to feedback your experiences using the workbook

Section 5 shows the methodology as a process flow

NB The workbook is one of the deliverables of a 3 year PhD research project entitled 'A Soft Systems Approach to the Formulation of a Manufacturing Strategy' funded from a studentship from the Engineering and Physical Sciences Research Council under the guidance of Dr Steve Childe, Dr Roger Maill and Dr Jan Bennett. The workbook is a result of research into the process of Manufacturing Strategy Formulation within the UK Aerospace Industry and is intended as to be used as a template and guide for the development of a Manufacturing Strategy. The workbook is descriptive as opposed to prescriptive and prefers to give indicators as a guide to learning as opposed to prescriptive methods which have to be followed.

If you have any comments on the usability, format, content or process of the workbook. Please contact

*T J Greswell
School of Computing
University of Plymouth
Drake Circus, Plymouth
Devon, PL4 8AA, UK*

*TGRESWELL@plym.ac.uk
Tel 01752 - 232620
Fax 01752 - 232540*

*Page 3
18/09/97 15:56
Version: draft*

Section 1

1. Section 1 - The Theoretical Base

Section 1 introduces the general concepts of the process of manufacturing strategy formulation, the reasoning behind using a soft systems approach, the benefits of using the approach and the issues to bear in mind when using the work book.

1.1 Manufacturing Strategy

Manufacturing Strategy is all about constructing advantage from the manufacturing system and is a simple yet powerful concept for positioning the manufacturing process or function to support, guide and influence the competitiveness of its organisation. Manufacturing Strategy can be described using the analogy of a boat, the direction and destination of the vessel [the organisation] depends on several factors which are dynamic and to a degree unpredictable. This could include tides [customer satisfaction], rocks [legislation], the weather [emerging new technologies] and so on. The tools used to help vessels navigate could include charts, Global positioning systems, as well as the experience of the skipper and crew.

Therefore using this analogy regarding Manufacturing Strategy, the workbook should be seen as a chart to enable you to plot your journey and direction using methods derived from current Operations Management theory and tested within British Industry. Together with the stakeholders experiences within operations management, should enable the formulation of a useful and implementable Manufacturing Strategy.

A note of caution: the methodology is a guide and a framework for developing a manufacturing strategy - each organisation has its own values, beliefs and ways of working, therefore the examples shown in section 3 should not be copied but used as learning opportunities.

1.2 Soft Systems Thinking [SST]

SST has been developed as a complementary approach to typical reductionist approaches to problem solving. The approach looks at the whole system and incorporates different points of view held by the

*Page 4
18/09/97 15:56
Version: draft*

stakeholders involved in the Manufacturing Strategy formulation process. The SST approach looks at strategy formulation as a problem situation. The stakeholders within the manufacturing organisation may realise the need for a coherent strategy to increase competitiveness, but may be unclear as to how to achieve this. The SSM approach to Manufacturing Strategy Formulation aims to guide the operations manager and stakeholders through several cycles of learning in order to formulate a manufacturing strategy which is appropriate for their organisation.

1.3 The Soft Systems Approach to Manufacturing Strategy Formulation

The approach has been developed in a workbook format which can be used by the practitioner together with a facilitator or solely by the practitioner together with the guidance notes provided.

The objective of the methodology is to develop and evolve an implementable manufacturing strategy taking into account the different worldviews of the process stakeholders and by using the principles of systemicity and debate to encourage learning and aid in implementation.

1.4 Benefits of using the approach

As with any tool or technique it is important to explain the benefits of using the approach together with the thinking and research behind the development of the methodology. The methodology is built using systems thinking, soft systems methods, and 3 Manufacturing Strategy Archetypes. The benefits of using the methodology are summarised below:

- All stakeholders are encouraged to participate in the process of formulating a Manufacturing Strategy
- A better understanding and consensus should be reached by exposing different perspectives held by the stakeholders during the development of root definitions for the proposed Manufacturing Systems
- The approach takes a systemic view of the manufacturing operation
- SST allows learning to occur about the relevant systems under analysis
- should help with implementation of the strategy due to the exposing of different points of view and shared learning
- the 3 current Manufacturing Strategy archetypes are introduced and used as a guide to understand the current mindsets within the organisation and to act as a catalyst for change if appropriate.

1.5 Issues to be considered whilst following the methodology

- * Who are the key stakeholders in the Manufacturing Strategy formulation process?
- * What is the 'best practise' for the Manufacturing Strategy Formulation process? - How can it be improved?
- * Who has the authority to implement the proposed changes?
- * What cant be changed?
- * How do we build confidence in the process?
- * Who has the power to impede the proposed changes? Who benefits from the process?
- * What is the knowledge and experience base within the organisation of using SST and developing Manufacturing Strategy?
- * Are sufficient resources in both time and key stakeholders available to ensure the process is ongoing?
- * How much influence does Manufacturing have within the organisation
- * Who is the process owner? I.e. who wants this process to happen?

Section 2

2. Section 2 - The Soft Systems Approach to Manufacturing Strategy

Section 2 has been developed as a tool to be used when formulating a manufacturing strategy using soft systems thinking. It provides an objective for each stage, deliverables and tasks to be followed, together with tools and templates.

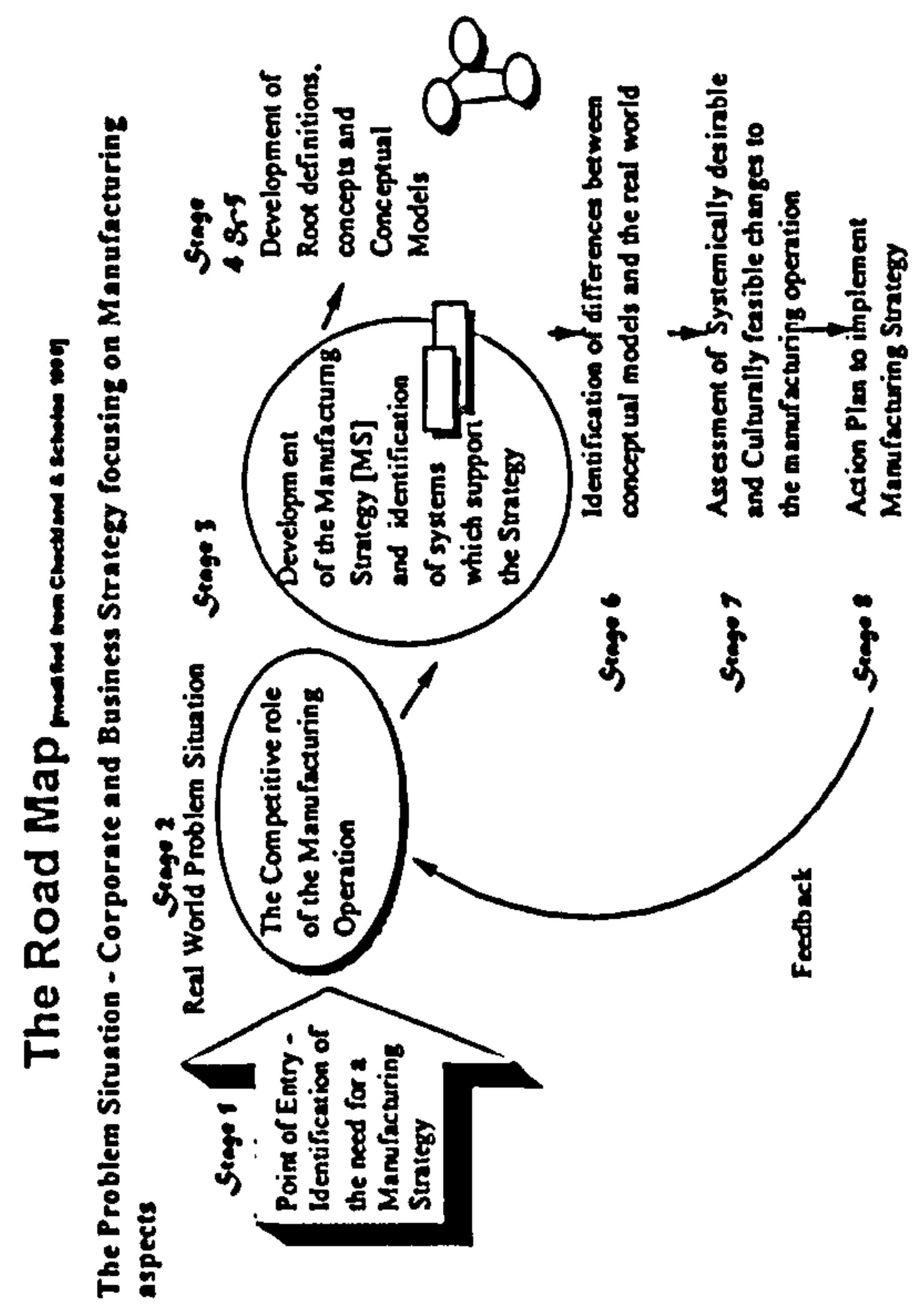

Stage 1

2.1 Does the Organisation see the need for change?

Is the organisation committed to developing a new or updated Manufacturing Strategy? This is a key stage in the Manufacturing Strategy formulation process and sets the tone for the development of the strategy. It is important to consider the place manufacturing has within your organisation, and the influence manufacturing can exert in supporting corporate objectives. Hayes and Wheelwright have developed a four stage model which is useful in determining your and other views of where manufacturing is seen in your organisation. This stage addresses the history of manufacturing's previous role within the organisation. This is important as it sets the scene for the development of the Manufacturing Strategy.

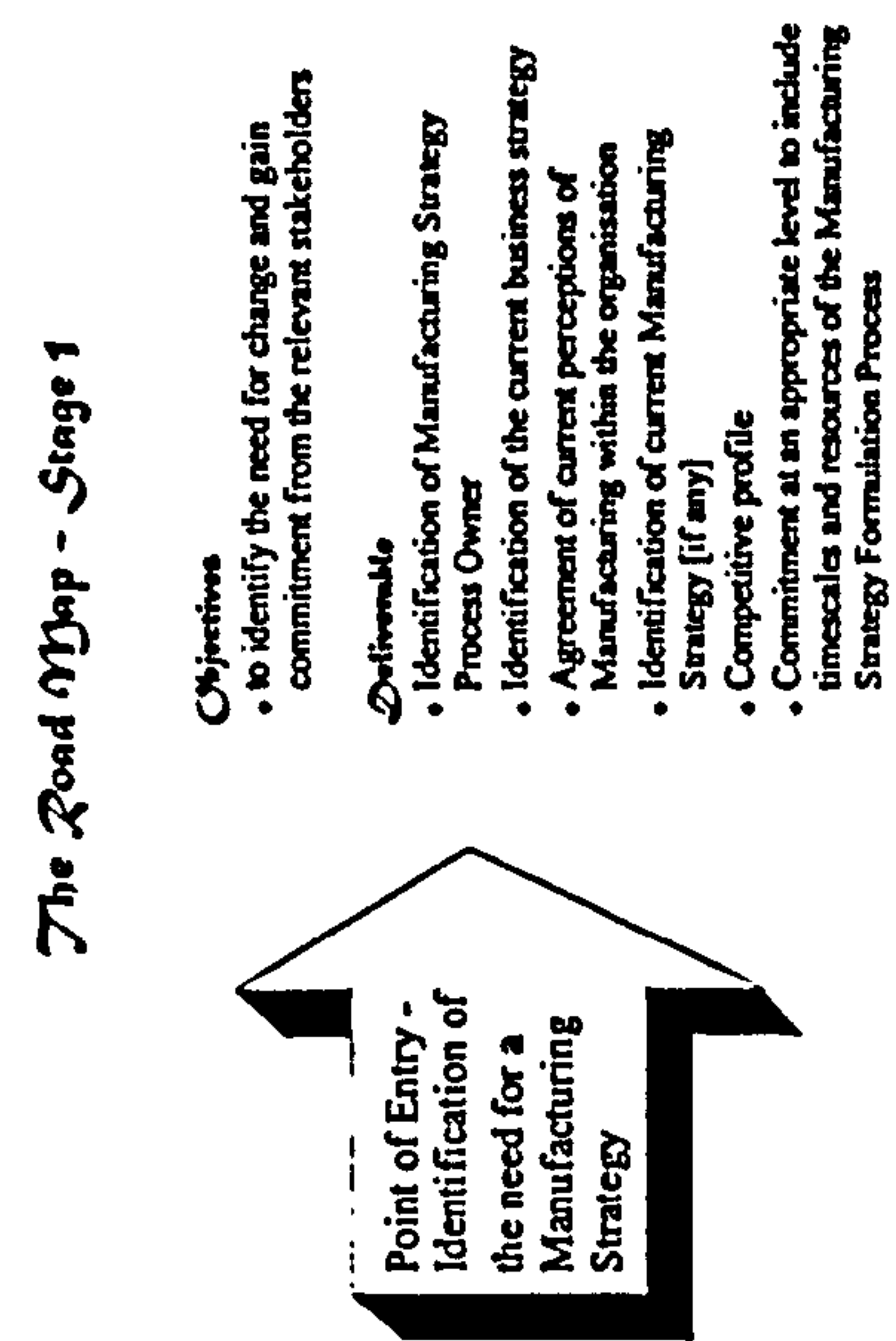

2.1.1 Task 1.1 Identify Manufacturing Strategy formulation process owner and key manufacturing stakeholders within the organisation

2.1.1.1 Participants

The Manufacturing Strategy Formulation Team

- Manufacturing / Operations Director / Managers
- Marketing Director / Manager
- Purchasing Director / Manager
- Technology Manager
- Others?

2.1.1.2 Sources of Information

- Organisation charts
- Current Strategy Documents
- Operations Plan
- Current Policy Documents

2.1.2 Task 1.2 Identify the current business strategy explicitly

2.1.2.1 Participants

The Manufacturing Strategy Formulation Process Owner and Team identified in task 1.1

2.1.2.2 Sources of Information

- Current Strategy Documents
- Operations Plan
- Current Policy Documents

2.1.2.3 Tools and techniques - Business Strategy Questionnaire

The questionnaire is designed to get the Manufacturing Strategy Formulation team to explicitly state what the business strategy is and help to determine what is required of Manufacturing to enable the organisation to support the business strategy. The data from the questionnaire will be used at a later date to build up a picture of the organisation and Manufacturing's role within it.

Your organisation and its business:

How would you describe your organisation's role within the aerospace industry?

- Prime Contractor
- Systems Integrator
- Systems Supplier
- Components Supplier

Who are your major customers? Please tick as many as appropriate

- Prime Contractors
- Systems Integrators
- Systems Suppliers
- Components Suppliers
- Defence - General
- Defence - Aerospace
- Civil - Aerospace
- Automotive Industry
- ?
- ?
- ?

Who are your main competitors?

Which one of the following best describes your main strategic business objectives for your organisation

- | | Short Term | Medium Term | Long Term | Not at all |
|---------------------------------|--------------------------|--------------------------|--------------------------|--------------------------|
| Cost leadership | <input type="checkbox"/> | <input type="checkbox"/> | <input type="checkbox"/> | <input type="checkbox"/> |
| Differentiation | <input type="checkbox"/> | <input type="checkbox"/> | <input type="checkbox"/> | <input type="checkbox"/> |
| Focus | <input type="checkbox"/> | <input type="checkbox"/> | <input type="checkbox"/> | <input type="checkbox"/> |
| Survival | <input type="checkbox"/> | <input type="checkbox"/> | <input type="checkbox"/> | <input type="checkbox"/> |
| Sustain current position | <input type="checkbox"/> | <input type="checkbox"/> | <input type="checkbox"/> | <input type="checkbox"/> |
| Steady growth | <input type="checkbox"/> | <input type="checkbox"/> | <input type="checkbox"/> | <input type="checkbox"/> |
| Rapid growth | <input type="checkbox"/> | <input type="checkbox"/> | <input type="checkbox"/> | <input type="checkbox"/> |
| Develop new markets | <input type="checkbox"/> | <input type="checkbox"/> | <input type="checkbox"/> | <input type="checkbox"/> |
| Become no 1 in particular field | <input type="checkbox"/> | <input type="checkbox"/> | <input type="checkbox"/> | <input type="checkbox"/> |
| Become world class | <input type="checkbox"/> | <input type="checkbox"/> | <input type="checkbox"/> | <input type="checkbox"/> |
| Other | <input type="checkbox"/> | <input type="checkbox"/> | <input type="checkbox"/> | <input type="checkbox"/> |

If other, please briefly specify.

How do you mostly intend to achieve your objectives?

	Short term	Medium term	Long term	Short term	Medium term	Long term
Core competence focus	<input type="checkbox"/>	<input type="checkbox"/>	<input type="checkbox"/>	<input type="checkbox"/>	<input type="checkbox"/>	<input type="checkbox"/>
Core technologies focus	<input type="checkbox"/>	<input type="checkbox"/>	<input type="checkbox"/>	<input type="checkbox"/>	<input type="checkbox"/>	<input type="checkbox"/>
Research & Development	<input type="checkbox"/>	<input type="checkbox"/>	<input type="checkbox"/>	<input type="checkbox"/>	<input type="checkbox"/>	<input type="checkbox"/>
New Technology	<input type="checkbox"/>	<input type="checkbox"/>	<input type="checkbox"/>	<input type="checkbox"/>	<input type="checkbox"/>	<input type="checkbox"/>
Merger	<input type="checkbox"/>	<input type="checkbox"/>	<input type="checkbox"/>	<input type="checkbox"/>	<input type="checkbox"/>	<input type="checkbox"/>
Collaboration	<input type="checkbox"/>	<input type="checkbox"/>	<input type="checkbox"/>	<input type="checkbox"/>	<input type="checkbox"/>	<input type="checkbox"/>
Restructuring	<input type="checkbox"/>	<input type="checkbox"/>	<input type="checkbox"/>	<input type="checkbox"/>	<input type="checkbox"/>	<input type="checkbox"/>
Increase efficiency	<input type="checkbox"/>	<input type="checkbox"/>	<input type="checkbox"/>	<input type="checkbox"/>	<input type="checkbox"/>	<input type="checkbox"/>
				Innovation		
				New products		
				New Processes		
				Activity Based Costing		
				Training		
				Acquisition		
				Flexibility		
				Other		

If other please add more detail

How would you describe the structure of your organisation? [You can tick more than 1]

Functional	<input type="checkbox"/>	Business Process Focused	<input type="checkbox"/>	Project Focused	<input type="checkbox"/>	Temporary	<input type="checkbox"/>
Hierarchy	<input type="checkbox"/>	Matrix	<input type="checkbox"/>	Product focused	<input type="checkbox"/>	Other	<input type="checkbox"/>
Complicated	<input type="checkbox"/>	Flat	<input type="checkbox"/>				

How would you describe the culture of the organisation?

Adversarial	<input type="checkbox"/>	Innovative	<input type="checkbox"/>	Traditional Taylorist	<input type="checkbox"/>	Open and Honest	<input type="checkbox"/>
Blame culture	<input type="checkbox"/>	Forward Thinking	<input type="checkbox"/>	Ticking over	<input type="checkbox"/>	Other	<input type="checkbox"/>

2.1.2.4 Assimilation of data and Debate

The result of the questionnaire should provide the team with an explicit statement of the teams understanding of their business strategy. This should be expressed below:

The business strategy states:

2.1.3 Task 1.3 Identify the current perception of Manufacturing within the organisation.

2.1.3.1 Participants

The Manufacturing Strategy Formulation Process Owner and Team identified in task 1.1

2.1.3.2 Sources of Information

Own perceptions taking the culture of the organisation into account i.e. the artefacts, values and taken for granted.
Policies

2.1.3.3 Tools and techniques - Hayes and Wheelwright's 4 stage evolutionary Manufacturing model

Hayes and Wheelwright's 4 stage model has been used to describe the evolution of a Manufacturing organisation and can be useful to expose different stakeholder perceptions. Each key stakeholder should be asked to identify which stage they feel the manufacturing organisation has reached. No justification is required at this stage. The objective is to identify if there is a need for a Manufacturing Strategy or a need for an updated Manufacturing Strategy.

Stage	Description	Explanation
1.	Internally neutral	The objective is to minimise the negative impact of the manufacturing function. The manufacturing function is described as inward looking and tends to be reactive with a great deal of effort expended on 'fire fighting'.
2.	Externally neutral	The objective is to obtain parity with competitors usually following industry best practice. Stage 2 is achieved when the manufacturing organisation starts to look outwards and see what similar entities are doing and to identify appropriate best practice.
3.	Internally supportive:	Manufacturing exists to support business strategy. The manufacturing organisation is world class and up with the best. Manufacturing is consulted when changes are made in business strategy
4.	Externally supportive	Manufacturing capabilities shape business strategy in terms of the types of products developed and the ways in which markets are addressed. Manufacturing is seen as the basis for the long term health and success of the organisation. Manufacturing is seen as being proactive and innovative in its approach.

To help determine the perceptions of manufacturing within the organisation a matrix has been formulated as a guide. Use a highlighter to determine where you organisation currently sits.

Stage	People	Processes	Technology
Stage 1 Internally Neutral Minimise the negative effects of manufacturing Aiming for Repeatability 'Stop making mistakes'	<ul style="list-style-type: none"> Specialisation Point of entry not reached coordination Taylorism functional accountability 	<ul style="list-style-type: none"> Functional Organisation Quality improvement programmes Delivery focus 'get it out the door' 	<ul style="list-style-type: none"> Materials Resource Planning MRP Manufacturing Resource Planning MPR2 Scheduling Variance reporting Group technology
Stage 2 Externally Neutral maintain parity keep up with the competition Aiming for Stability 'be among the best'	<ul style="list-style-type: none"> Quality circles Teaming Mixing the disciplines 	<ul style="list-style-type: none"> SPC, JIT, DFM, CAPM, TQM, World Class Manufacturing, BPR Benchmarking Best Practice Just-In-Time Quality improvement Activity Based Costing focus on quality 	<ul style="list-style-type: none"> Manufacturing Resource Planning Process control Cells
Stage 3 Internally Supportive Manufacturing supports the business strategy Aiming for Flexibility 'be clearly the best'	<ul style="list-style-type: none"> Concurrent engineering Team based 	<ul style="list-style-type: none"> Business Process Focus, Supply chain management focus on cost throughput accounting 	<ul style="list-style-type: none"> Enterprise Resource Planning Information Technology underpins processes strategic investment in automation
Stage 4 Externally Supportive Manufacturing capabilities shape business strategy Aiming for Versatility 'sustain superiority through an operations advantage'	<ul style="list-style-type: none"> Development of core competence - skills and knowledge which are difficult to replicate Integrated product teams knowledge based organisation 'surgeon' structure' 	<ul style="list-style-type: none"> The learning organisation Blurring of functions Business process focused organisation Market creation using manufacturing competencies focus on product variability 	<ul style="list-style-type: none"> Systems Integration Product Information Environment Computer Integrated Manufacturing

Developed from Hayes and Wheelwright's 4 stage model and Laurie Ramanoo model.

2.1.3.4 Assimilation of Data and Debate

The matrix should be used to focus attention on what Manufacturing should be aiming for in order to support business objectives. A statement should be made identifying where the organisation currently appears to be and secondly where the organisation wants manufacturing to be.

The manufacturing organisation appears to be at stage

The organisation wants manufacturing to be at stage

Notes:

2.1.4 Task 1.4 Identify and explicitly state the current Manufacturing Strategy

2.1.4.1 Participants

The Manufacturing Strategy Formulation Process Owner and Team identified in task 1.1

2.1.4.2 Sources of Information

Organisational documents, family trees, personal knowledge, change management programmes, manufacturing operations policy documents

2.1.4.3 Assimilation of data and Debate

Explicitly state the current Manufacturing Strategy. If there is no Manufacturing Strategy written down describe the current emergent strategy if possible.

The current Manufacturing Strategy states:

Is the current Manufacturing Strategy adequate in meeting the strategic business objectives?

	Short term	Medium term	Long term
YES	<input type="checkbox"/>	<input type="checkbox"/>	<input type="checkbox"/>
NO	<input type="checkbox"/>	<input type="checkbox"/>	<input type="checkbox"/>
DON'T KNOW	<input type="checkbox"/>	<input type="checkbox"/>	<input type="checkbox"/>

If 'yes' to all - congratulations!!!!

If 'no' to any and your organisation wishes to change the situation proceed to STAGE 2

If 'don't know' - and you require more information to sway you one way or the other, proceed to task 1.5.

2.1.5 Task 1.5 Develop a competitive profile for the organisations most important product group

This task should only be completed at this stage if any of the key stakeholders within the manufacturing organisation do not see the need for a Manufacturing Strategy. The competitive profile is used to show the market / customer requirements of the product and whether the Manufacturing System can deliver what is needed.

2.1.5.1 Participants

The Manufacturing Strategy Formulation Process Owner and Team identified in task 1.1

2.1.5.2 Sources of Information

- Order winning and order qualifying criteria
- Customer orders
- Customer feedback
- Manufacturing performance measures

2.1.5.3 Tools and techniques - Competitive Profiling

This is to show any misalignment between how products compete in the market place and compared to how the manufacturing function supports the business objectives. Competitive profiling is used to show an organisation the mismatch between its market requirements and its achieved performance, thus showing that the manufacturing strategy approach is worthy of consideration. An example of competitive profiling is shown below.

Market Requirements

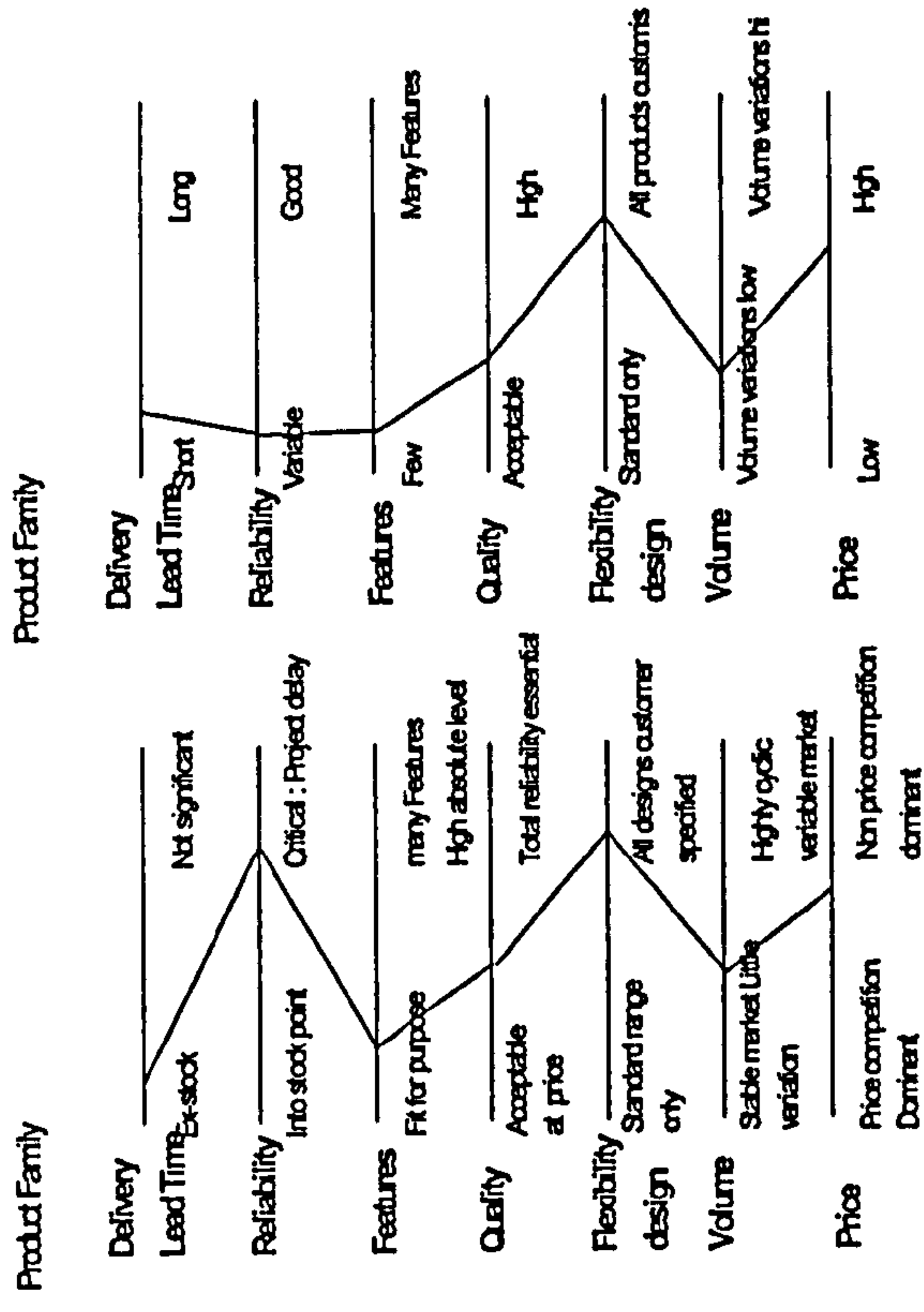

It is important at this stage to debate any anomalies that are found between what the customer wants - the market requirements and what the Manufacturing Systems currently deliver - the achieved performance

NOTES

Template for Competitive Profiling

Product Family _____
Market Requirements **Achieved Performance**

Product Family	_____	Product Family	_____
Delivery	_____	Delivery	_____
Lead Time	Ex-stock Not significant	Lead Time	Short Long
Reliability	_____	Reliability	_____
	into stock point Critical : Project delay		Variable Good
Features	_____	Features	_____
	Fit for purpose many Features		Few Many Features
	_____		_____
	Acceptable High absolute level		Acceptable High
	at price Total reliability essential		
Flexibility	_____	Flexibility	_____
design	Standard range All designs customer	design	Standard only All products customs
	only specified		
Volume	_____	Volume	_____
	Stable market Little Highly cyclic		Volume variations low Volume variations hi
	variation variable market		
Price	_____	Price	_____
	Price competition Non price competition		Low High
	Dominant dominant		

For the MARKET REQUIREMENTS

The criteria that customers have for any specific product group should be plotted on the template. The profile is asking 'how do your products win in the market place?'

For the ACHIEVED PERFORMANCE

The criteria is asking about the current criteria within the organisation used for the product group described above

When the two profiles have been drawn, photocopy onto acetates and place one on the other - ask the question?? Do they match up??? Are the Manufacturing Systems aligned with what the market or business wants? If there are major mismatches a Manufacturing Strategy would help you considerably. Stage 2 onwards will guide you through the development of your Manufacturing Strategy.

2.1.6 Task 1.6 Gain commitment for the next stage of the Manufacturing Strategy Formulation process.

If all key stakeholders now appreciate the need / requirement for a Manufacturing Strategy task 1.5 should be completed to ensure all stakeholders are aware of the timescales and commitment available to them.

An explicit statement is required at this stage that it is recognised that a problem exists and that there is a need to process with the workbook.

2.1.6.1 What we have achieved by this stage

- an explicit statement of the Manufacturing Strategy Formulation process owner and team members
- an explicit statement of the business strategy
- an explicit statement of the current perception of Manufacturing using Hayes and Wheelwrights 4 stage model
- an explicit statement of the current Manufacturing Strategy [if one exists]
- a statement of commitment for the continuation of the process
- an explicit statement of the identification that a problem exists
- the identification of the need for the process to continue

Stage 2

2.2 The Manufacturing Operation and its effect on the competitiveness of the organisation [The real world problem situation - unstructured]

The Road Map - Stage 2

Objectives

- to develop an understanding of the current situation of the manufacturing operation and its influences, including the environment, key issues concerning customers, products, suppliers, competitors, problems

Deliverable

- Completion of manufacturing questionnaire
- The current situation of the manufacturing operation depicting key issues and interactions to develop a greater understanding in diagramatic form

Real World Problem Situation

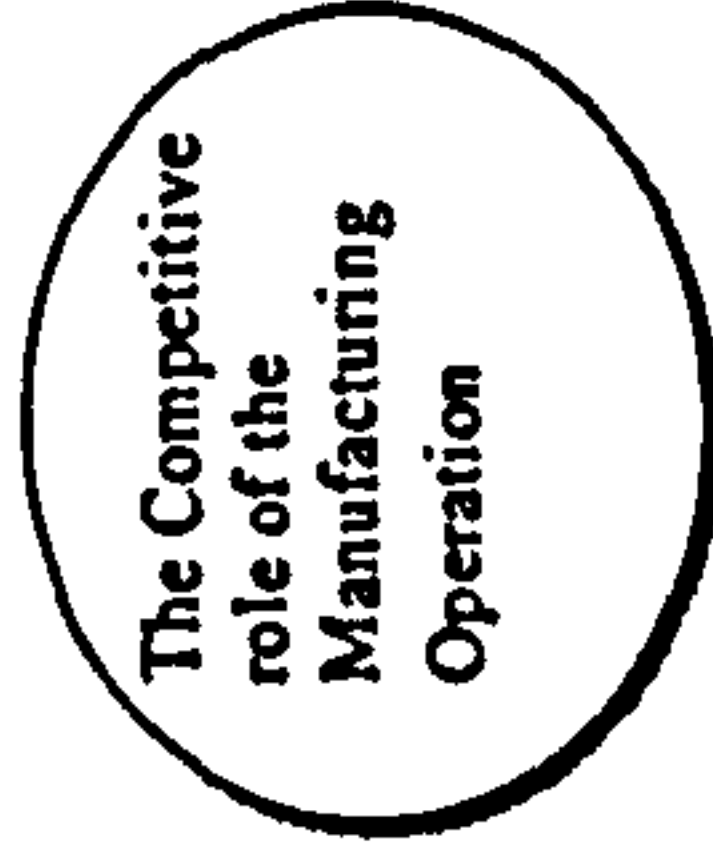

2.2.1 Task 2.1 Questionnaire for the development of understanding of the manufacturing organisation

The questionnaire will be divided into several sections. Each section will ask you to think about certain aspects of your manufacturing operation, manufacturing philosophy, your customers, your products, and your current manufacturing strategy. The questionnaire will then enable the development of diagrams to show the current situation as you see it. Each key stakeholder should be asked to complete the questionnaire, it must be stressed that at this stage it is the AS IS of the manufacturing operation [the real world] not how you would like to see the manufacturing operation evolve - this will come later

2.2.1.1 Participants

The Manufacturing Strategy Formulation Process Owner and Team identified in task 1.1

2.2.1.2 Sources of Information

Organisation wide

2.2.1.3 Tools and Techniques - Manufacturing Strategy Questionnaire

Aim
1. to provide you with a guide when you are drawing your rich picture
2. to provide an initial audit tool to assess the current situation of manufacturing

The Manufacturing Operation

How would you describe the current operating philosophy within Manufacturing?

Continuous Improvement <input type="checkbox"/>	Total Quality Management <input type="checkbox"/>	World Class Manufacturing <input type="checkbox"/>	Just -In-Time <input type="checkbox"/>
Business Process Focus <input type="checkbox"/>	Optimised Production Technology <input type="checkbox"/>	Lean Manufacturing <input type="checkbox"/>	Core Competence Management <input type="checkbox"/>
The Learning Organisation <input type="checkbox"/>	Concurrent Engineering <input type="checkbox"/>	Multi skilled teams <input type="checkbox"/>	Other <input type="checkbox"/>
Process Improvement <input type="checkbox"/>	Enterprise Resource Planning <input type="checkbox"/>		

How would you describe your current Manufacturing Strategy? [If you have one]

- | | Mostly | Slightly | Not at all |
|--|--------------------------|--------------------------|--------------------------|
| 1 Alignment of manufacturing systems with order winners / order qualifiers of different product groups | <input type="checkbox"/> | <input type="checkbox"/> | <input type="checkbox"/> |
| 2 Continuous improvement to become a world class manufacturing organisation | <input type="checkbox"/> | <input type="checkbox"/> | <input type="checkbox"/> |
| 3 Development of manufacturing core competences to develop new markets (terming organisation) | <input type="checkbox"/> | <input type="checkbox"/> | <input type="checkbox"/> |
| 4 Other - please specify | <input type="checkbox"/> | <input type="checkbox"/> | <input type="checkbox"/> |

What are the key drivers to the manufacturing strategy?

- | | | | |
|-----------------------|--------------------------|----------------------|--------------------------|
| Cost | <input type="checkbox"/> | Delivery Reliability | <input type="checkbox"/> |
| Quality | <input type="checkbox"/> | Delivery Flexibility | <input type="checkbox"/> |
| Flexibility | <input type="checkbox"/> | Product Reliability | <input type="checkbox"/> |
| Agility | <input type="checkbox"/> | Core competences | <input type="checkbox"/> |
| Leanness | <input type="checkbox"/> | Innovation | <input type="checkbox"/> |
| Customer Satisfaction | <input type="checkbox"/> | Other | <input type="checkbox"/> |

What technique/intervention are used to promote the above key drivers?

- | | | | |
|---|--------------------------|-----------------------------------|--------------------------|
| Total Quality Management | <input type="checkbox"/> | Investors in People | <input type="checkbox"/> |
| Benchmarking | <input type="checkbox"/> | Core competences | <input type="checkbox"/> |
| Customer focused | <input type="checkbox"/> | Business Process Re-engineering | <input type="checkbox"/> |
| Contingency focused | <input type="checkbox"/> | BS 5750 / ISO 9000 | <input type="checkbox"/> |
| Lean production | <input type="checkbox"/> | Baldrige and other quality awards | <input type="checkbox"/> |
| Statistical Process Control | <input type="checkbox"/> | Group Technology | <input type="checkbox"/> |
| Just In Time Manufacturing | <input type="checkbox"/> | CAD/CAM | <input type="checkbox"/> |
| Optimized Production Technology - theory of constraints | <input type="checkbox"/> | CAPM | <input type="checkbox"/> |
| Automation | <input type="checkbox"/> | Robotics | <input type="checkbox"/> |
| Best practice / World Class Manufacturing | <input type="checkbox"/> | Other | <input type="checkbox"/> |

How would you describe the overall structure within Manufacturing?

- | | | | | | | | |
|-------------------------|--------------------------|----------------|--------------------------|-------------------|--------------------------|-------|--------------------------|
| Multi Disciplined Teams | <input type="checkbox"/> | Cell Structure | <input type="checkbox"/> | Focused factories | <input type="checkbox"/> | Other | <input type="checkbox"/> |
|-------------------------|--------------------------|----------------|--------------------------|-------------------|--------------------------|-------|--------------------------|

What are the issues that cause manufacturing the most pain at present?

- | | | | | | | | | | |
|--------------|--------------------------|------------------|--------------------------|-------------------|--------------------------|-------------------------|--------------------------|------------------------|--------------------------|
| Shortages | <input type="checkbox"/> | Quality | <input type="checkbox"/> | Costs | <input type="checkbox"/> | Suppliers | <input type="checkbox"/> | Customers | <input type="checkbox"/> |
| Team working | <input type="checkbox"/> | Change | <input type="checkbox"/> | Finance | <input type="checkbox"/> | Delivery | <input type="checkbox"/> | Excess Inventory | <input type="checkbox"/> |
| Marketing | <input type="checkbox"/> | Commercial | <input type="checkbox"/> | Projects | <input type="checkbox"/> | New Product Development | <input type="checkbox"/> | Information Technology | <input type="checkbox"/> |
| Processes | <input type="checkbox"/> | The organisation | <input type="checkbox"/> | Operating Systems | <input type="checkbox"/> | Other | <input type="checkbox"/> | | |

Your Products

Please list your major product groups

A
B
C
D
E
F

Please indicate each major product group on the product - process matrix [Hayes and Wheelwright]

Product - Process Matrix

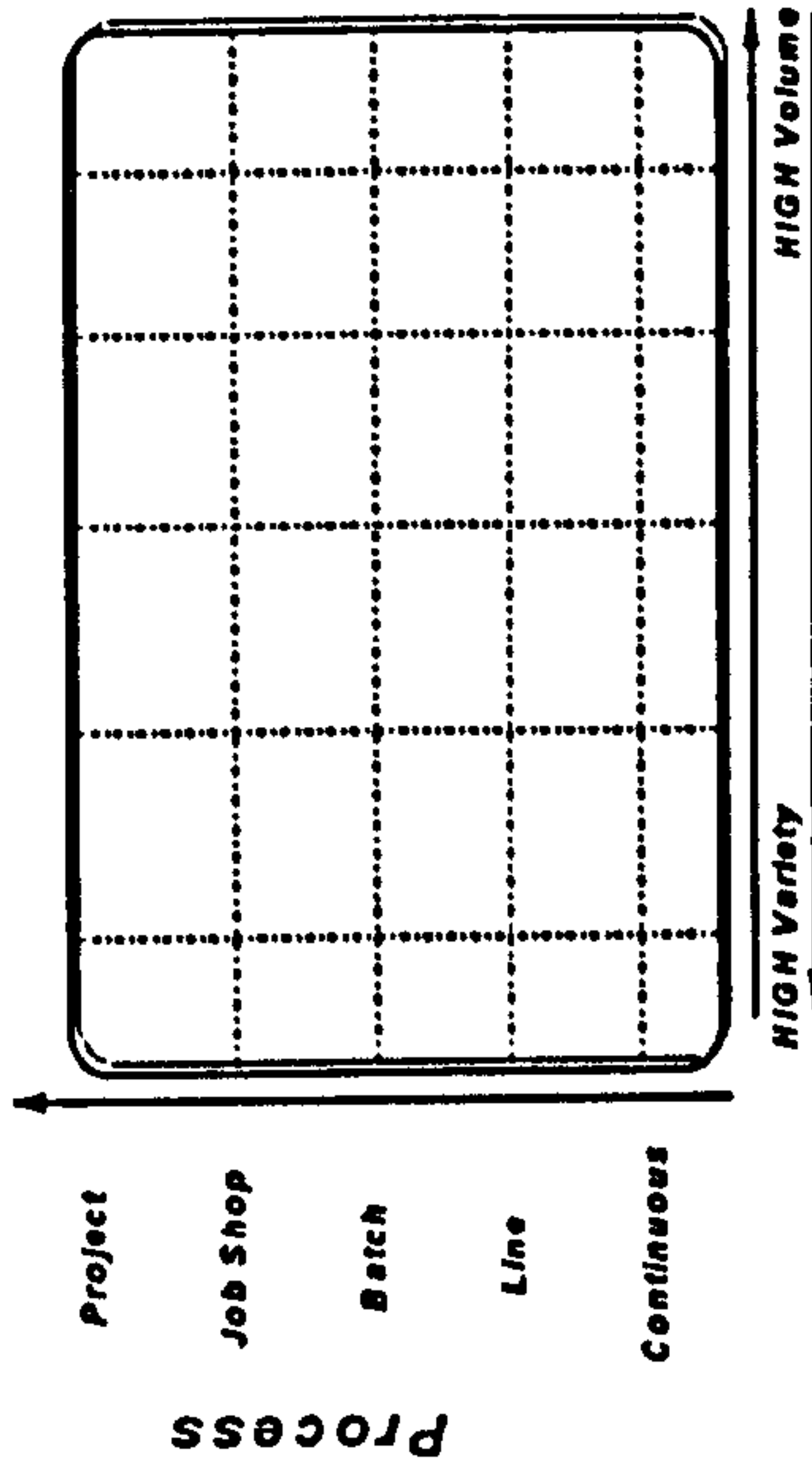

For each Product Group do you

Product Group	A	B	C	D	E	F
Engineer to order						
Make to stock						
Make to order						
Assemble to order						

Order winners and order qualifiers

Which of these characteristics are absolutely necessary for this product to be considered by a customer in its market place?

[Order Qualifier] please tick all relevant characteristics

Product Group	A	B	C	D	E	F	?	?	?
Initial Procurement Cost	<input type="checkbox"/>	<input type="checkbox"/>	<input type="checkbox"/>	<input type="checkbox"/>	<input type="checkbox"/>	<input type="checkbox"/>	<input type="checkbox"/>	<input type="checkbox"/>	<input type="checkbox"/>
Life Cycle Cost	<input type="checkbox"/>	<input type="checkbox"/>	<input type="checkbox"/>	<input type="checkbox"/>	<input type="checkbox"/>	<input type="checkbox"/>	<input type="checkbox"/>	<input type="checkbox"/>	<input type="checkbox"/>
Product Quality	<input type="checkbox"/>	<input type="checkbox"/>	<input type="checkbox"/>	<input type="checkbox"/>	<input type="checkbox"/>	<input type="checkbox"/>	<input type="checkbox"/>	<input type="checkbox"/>	<input type="checkbox"/>
After sales service quality	<input type="checkbox"/>	<input type="checkbox"/>	<input type="checkbox"/>	<input type="checkbox"/>	<input type="checkbox"/>	<input type="checkbox"/>	<input type="checkbox"/>	<input type="checkbox"/>	<input type="checkbox"/>
Delivery Reliability	<input type="checkbox"/>	<input type="checkbox"/>	<input type="checkbox"/>	<input type="checkbox"/>	<input type="checkbox"/>	<input type="checkbox"/>	<input type="checkbox"/>	<input type="checkbox"/>	<input type="checkbox"/>
Flexibility	<input type="checkbox"/>	<input type="checkbox"/>	<input type="checkbox"/>	<input type="checkbox"/>	<input type="checkbox"/>	<input type="checkbox"/>	<input type="checkbox"/>	<input type="checkbox"/>	<input type="checkbox"/>
Product Maintainability	<input type="checkbox"/>	<input type="checkbox"/>	<input type="checkbox"/>	<input type="checkbox"/>	<input type="checkbox"/>	<input type="checkbox"/>	<input type="checkbox"/>	<input type="checkbox"/>	<input type="checkbox"/>
Product Reliability	<input type="checkbox"/>	<input type="checkbox"/>	<input type="checkbox"/>	<input type="checkbox"/>	<input type="checkbox"/>	<input type="checkbox"/>	<input type="checkbox"/>	<input type="checkbox"/>	<input type="checkbox"/>
Other	<input type="checkbox"/>	<input type="checkbox"/>	<input type="checkbox"/>	<input type="checkbox"/>	<input type="checkbox"/>	<input type="checkbox"/>	<input type="checkbox"/>	<input type="checkbox"/>	<input type="checkbox"/>

Which of these characteristics would help a customer choose your product over the competition?

[Order Winner] please tick all relevant characteristics

Product Group	A	B	C	D	E	F	?	?	?
Initial Procurement Cost	<input type="checkbox"/>	<input type="checkbox"/>	<input type="checkbox"/>	<input type="checkbox"/>	<input type="checkbox"/>	<input type="checkbox"/>	<input type="checkbox"/>	<input type="checkbox"/>	<input type="checkbox"/>
Life Cycle Cost	<input type="checkbox"/>	<input type="checkbox"/>	<input type="checkbox"/>	<input type="checkbox"/>	<input type="checkbox"/>	<input type="checkbox"/>	<input type="checkbox"/>	<input type="checkbox"/>	<input type="checkbox"/>
Product Quality	<input type="checkbox"/>	<input type="checkbox"/>	<input type="checkbox"/>	<input type="checkbox"/>	<input type="checkbox"/>	<input type="checkbox"/>	<input type="checkbox"/>	<input type="checkbox"/>	<input type="checkbox"/>
After sales service quality	<input type="checkbox"/>	<input type="checkbox"/>	<input type="checkbox"/>	<input type="checkbox"/>	<input type="checkbox"/>	<input type="checkbox"/>	<input type="checkbox"/>	<input type="checkbox"/>	<input type="checkbox"/>
Delivery Reliability	<input type="checkbox"/>	<input type="checkbox"/>	<input type="checkbox"/>	<input type="checkbox"/>	<input type="checkbox"/>	<input type="checkbox"/>	<input type="checkbox"/>	<input type="checkbox"/>	<input type="checkbox"/>
Flexibility	<input type="checkbox"/>	<input type="checkbox"/>	<input type="checkbox"/>	<input type="checkbox"/>	<input type="checkbox"/>	<input type="checkbox"/>	<input type="checkbox"/>	<input type="checkbox"/>	<input type="checkbox"/>
Product Maintainability	<input type="checkbox"/>	<input type="checkbox"/>	<input type="checkbox"/>	<input type="checkbox"/>	<input type="checkbox"/>	<input type="checkbox"/>	<input type="checkbox"/>	<input type="checkbox"/>	<input type="checkbox"/>
Product Reliability	<input type="checkbox"/>	<input type="checkbox"/>	<input type="checkbox"/>	<input type="checkbox"/>	<input type="checkbox"/>	<input type="checkbox"/>	<input type="checkbox"/>	<input type="checkbox"/>	<input type="checkbox"/>
Other	<input type="checkbox"/>	<input type="checkbox"/>	<input type="checkbox"/>	<input type="checkbox"/>	<input type="checkbox"/>	<input type="checkbox"/>	<input type="checkbox"/>	<input type="checkbox"/>	<input type="checkbox"/>

The above data can now be used as the basis of debate to initiate a greater understanding of the Manufacturing organisation and to develop diagrammatics of the Manufacturing organisation that will be useful further on in the workbook. The questionnaire should be completed by all major stakeholders in the Manufacturing Strategy Formulation process individually and then the findings should be debated as a group.

2.2.2 Task 2.2 Assimilate data from completed questionnaires to get different perspectives from stakeholders

2.2.3 Task 2.3 Debate findings - reach a general consensus on important issues

2.2.4 Task 2.4 Development of diagrams, pictures to portray the shared understanding of the current Manufacturing Operation

A pictorial view of the manufacturing organisation should be developed using data from the questionnaires. A mind map may be useful in consolidating the data collected from the questionnaire before any rich picture is drawn.

2.2.4.1 Participants

The Manufacturing Strategy Formulation Process Owner and Team identified in task 1.1

2.2.4.2 Sources of Information

The rich picture questionnaire
Stakeholders views and assumptions
Organisation documents

As much information as possible to expose the issues facing the manufacturing organisation*

2.2.4.3 Tools and techniques

The following are examples of diagrammatics of the manufacturing organisation

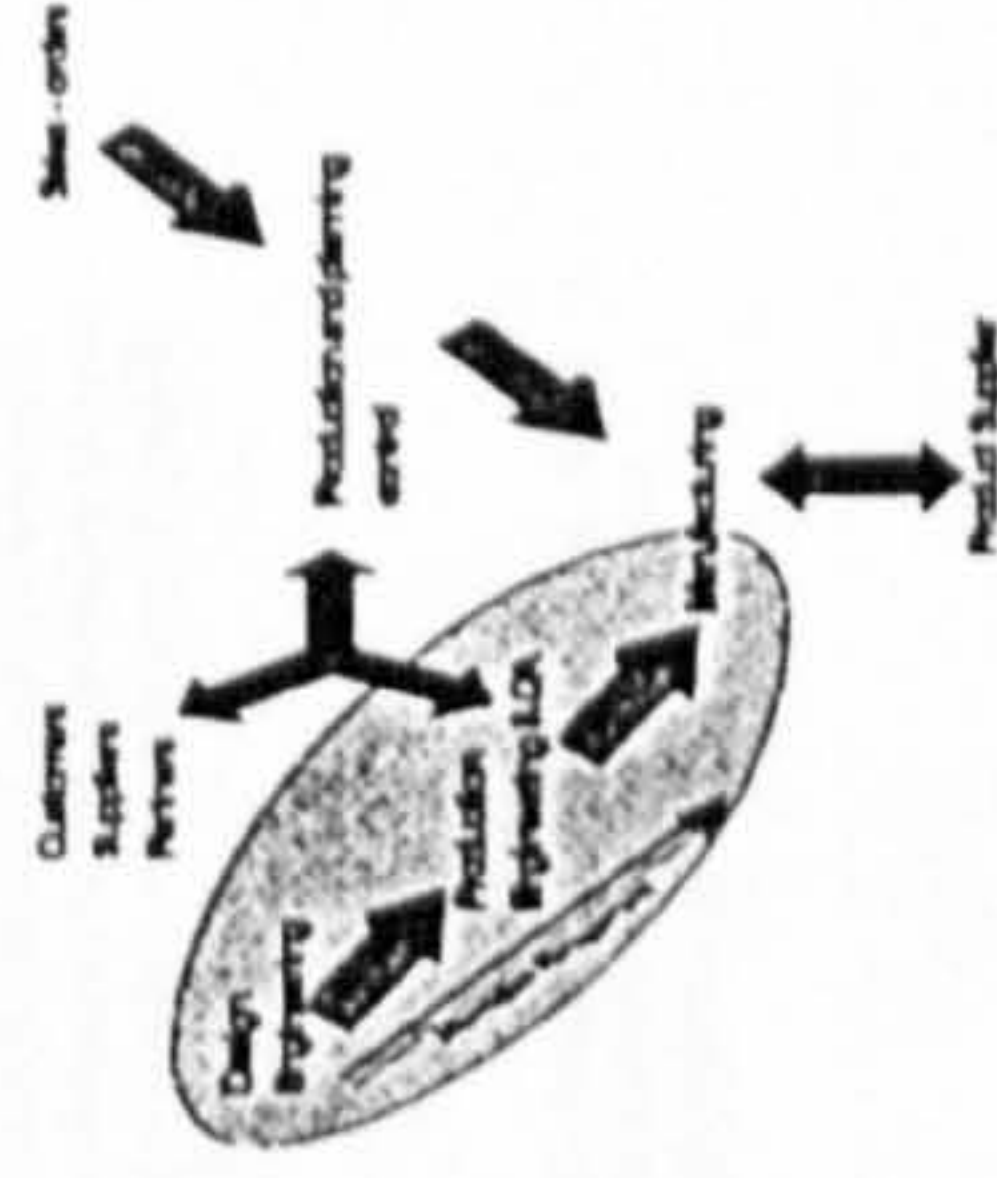

2.2.4.4 What we have achieved by this stage

- completed questionnaire on the manufacturing operation and its environment
- Diagrammatic representations of the shared understanding of the current manufacturing organisation
- a rich source of data for use in stage 6 when we compare what we have [the real world situation] with what we want [our conceptual models]

THIS COMPLETES

THE 'AS IS' SECTION OF THE WORKBOOK

- THE DATA WILL BE DEBATED, ASSIMILATED

AND USED IN

STAGE 6

Stage 3

2.3 The Problem Situation - The development of the Manufacturing Strategy? *What do we want Manufacturing to achieve [How and What?] and how do we want the relevant systems to support it?*

In soft systems thinking we identify relevant systems which can help us in our problem situation, we must take into account the MANUFACTURING OBJECTIVES when we identify the relevant systems within manufacturing which will have an impact on meeting those business and manufacturing objectives.

What manufacturing systems would be required and are relevant in order to meet the manufacturing objectives?

The Road Map - Stage 3

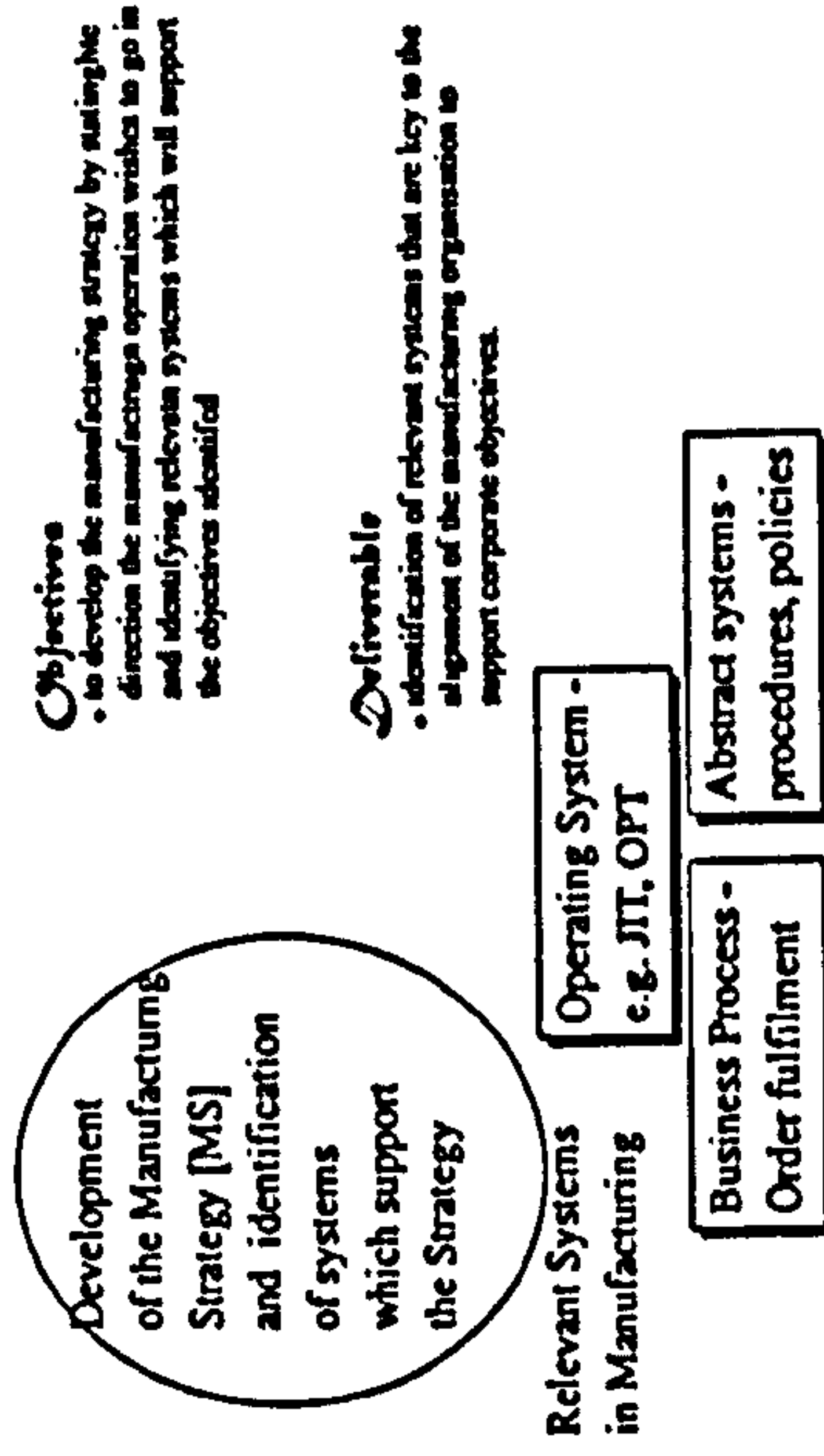

2.3.1 Task 3.1 Develop a statement of what the organisation expects of manufacturing. Identify specific strategic objectives for manufacturing.

This task involves formulating what the organisation and manufacturing expects of the manufacturing operation. The task identifies the direction of the manufacturing organisation and states it explicitly.

The following questions should be considered

1. What does the business expect of manufacturing?
 2. What does manufacturing expect of the business?
 3. How can manufacturing be aligned most effectively to support corporate and business objectives?
- 3 Manufacturing Strategy Archetypes have been developed to summarise current thinking within the Manufacturing Strategy Domain. The Manufacturing Strategy Archetypes should be used as a source of debate when determining the type of Manufacturing Strategy developed. This will be closely linked with the business and corporate objectives.

2.3.1.1 Complete Manufacturing Strategy Orientation questionnaire.

To stimulate the debate surrounding the proposed direction of manufacturing and to help the team to decide which archetype they currently reside in, and to draw your attention to the alternatives. A hybrid could be appropriate for your organisation. The archetypes have been developed as a method for describing current thinking around Manufacturing Strategy.

2.3.1.2 Participants

Manufacturing Strategy Formulation Process Owner and Stakeholders

2.3.1.3 Sources of Information

Organisational Knowledge

2.3.1.4 Tools and techniques - Manufacturing Strategy Orientation Questionnaire

Below are several sets of assertions about Manufacturing Strategy. Consider each set in turn and allocate 10 points between the alternatives to reflect your personal opinions. You may distribute the 10 points in anyway you see as appropriate. The results should be debated amongst the team and used to determine the direction for manufacturing.

1 A Manufacturing Strategy should:

- support the corporate and business strategy
- limit the 'damage' done to the organisation by manufacturing
- lead the direction of the organisation

2 The most important role for a Manufacturing Strategy is to develop:

- a world class manufacturing organisation
- a market led / customer focused organisation
- a knowledge based learning organisation

3 The process of developing a Manufacturing Strategy should:

- be left to manufacturing and no one else
- include both marketing, manufacturing and finance people
- include all the major stakeholders with an interest in the manufacturing operation

4 A Manufacturing Strategy is:

- unnecessary
- crucial to the success of the organisation
- a necessary 'evil'

5 Which of the following are key for a successful Manufacturing Strategy

- identification of order winners and order qualifiers for each product group
- identification of best practice within the Industry and subsequent implementation of best practice
- the development of core competences within Manufacturing which can be used to provide a clear competitive advantage

2.3.1.5 Manufacturing Strategy Archetype Concepts

The Manufacturing Strategy Archetypes should be used as a source of debate and a template to determine which archetype your manufacturing organisation tends towards. Use a highlighter to show the manufacturing organisation tendencies towards one or all three of the archetypes.

2.3.1.5.1 The market led - customer focused concept for Manufacturing Strategy

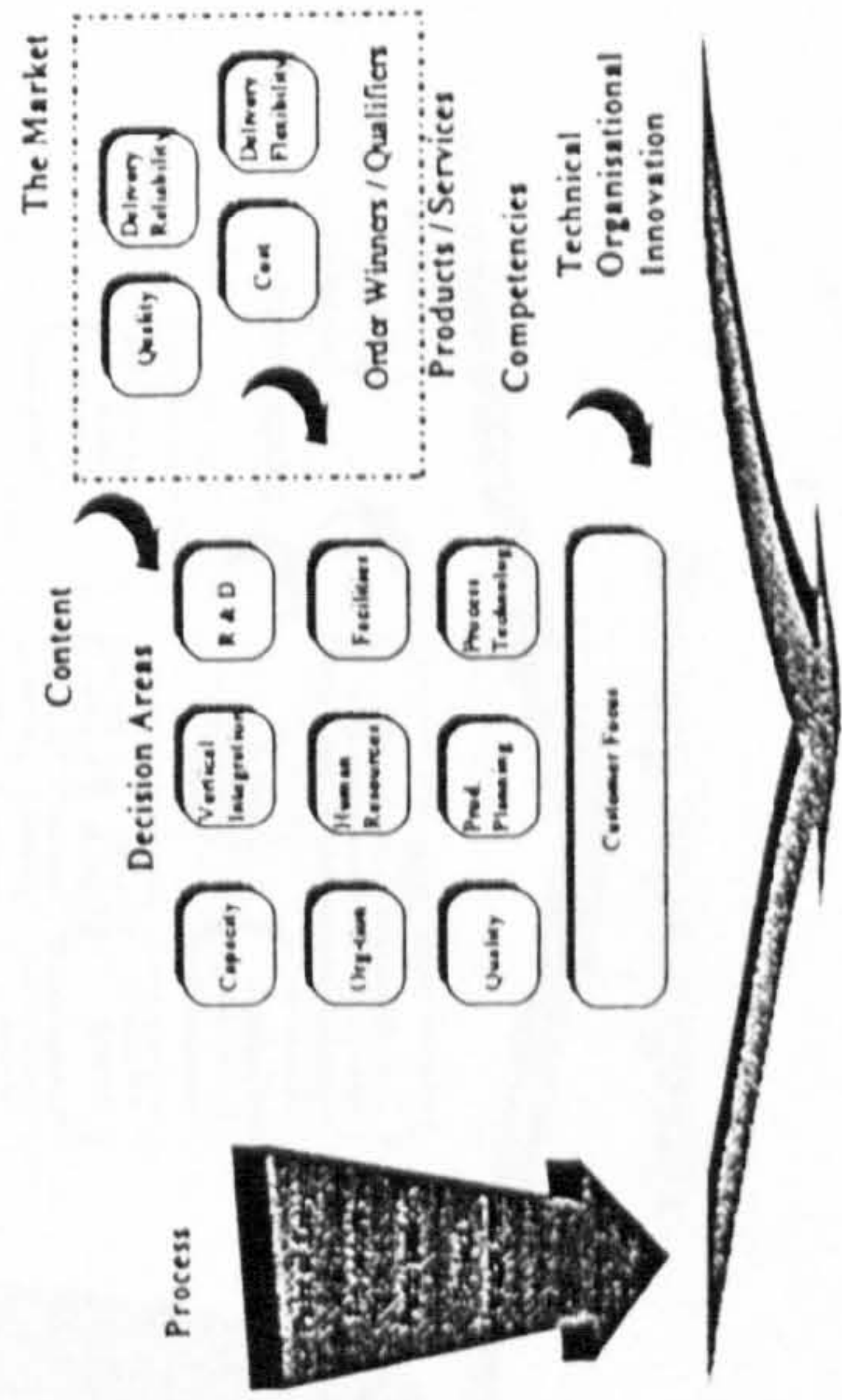

Manufacturing Strategy

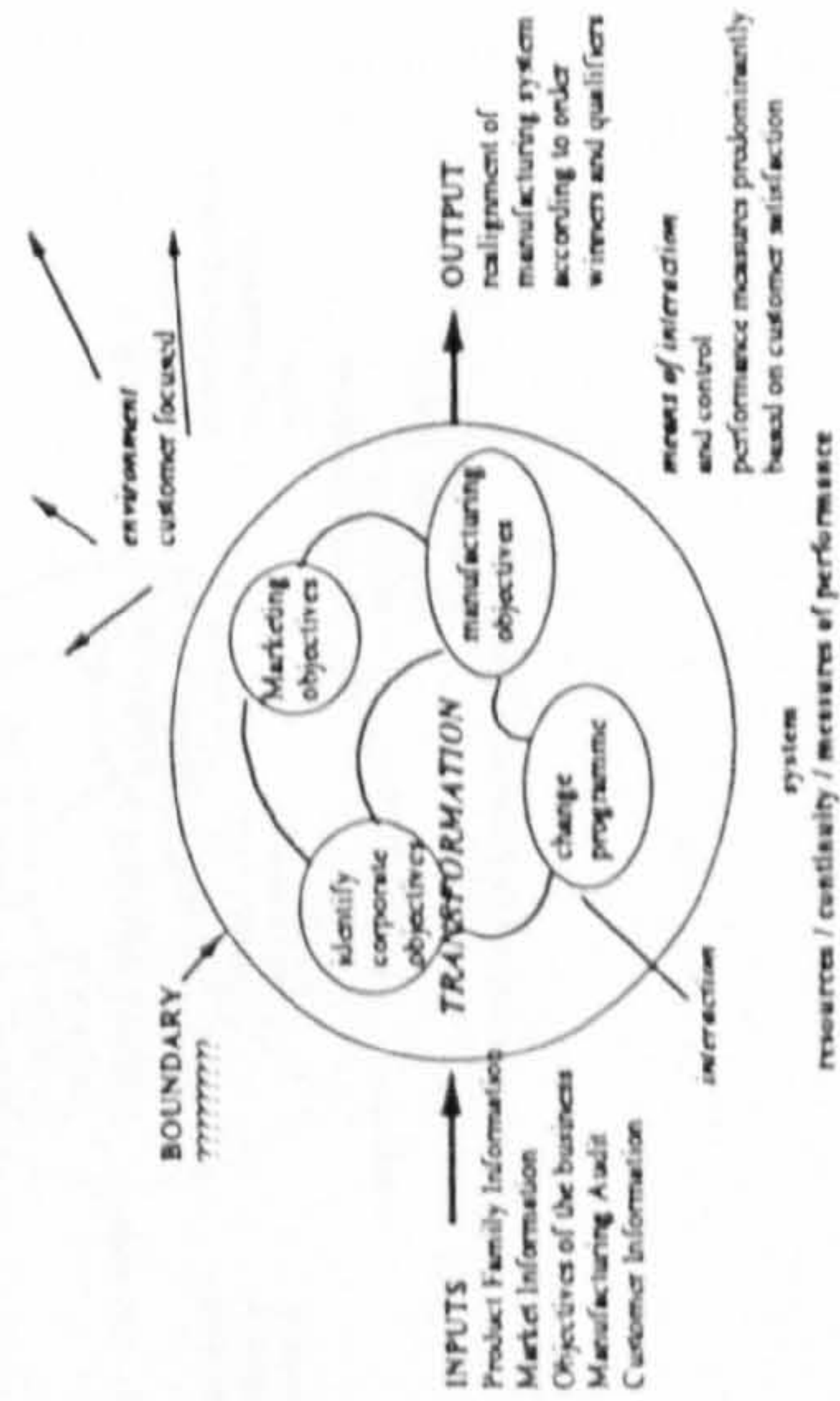

2.3.1.5.2 The best practice - excellence concept for Manufacturing Strategy

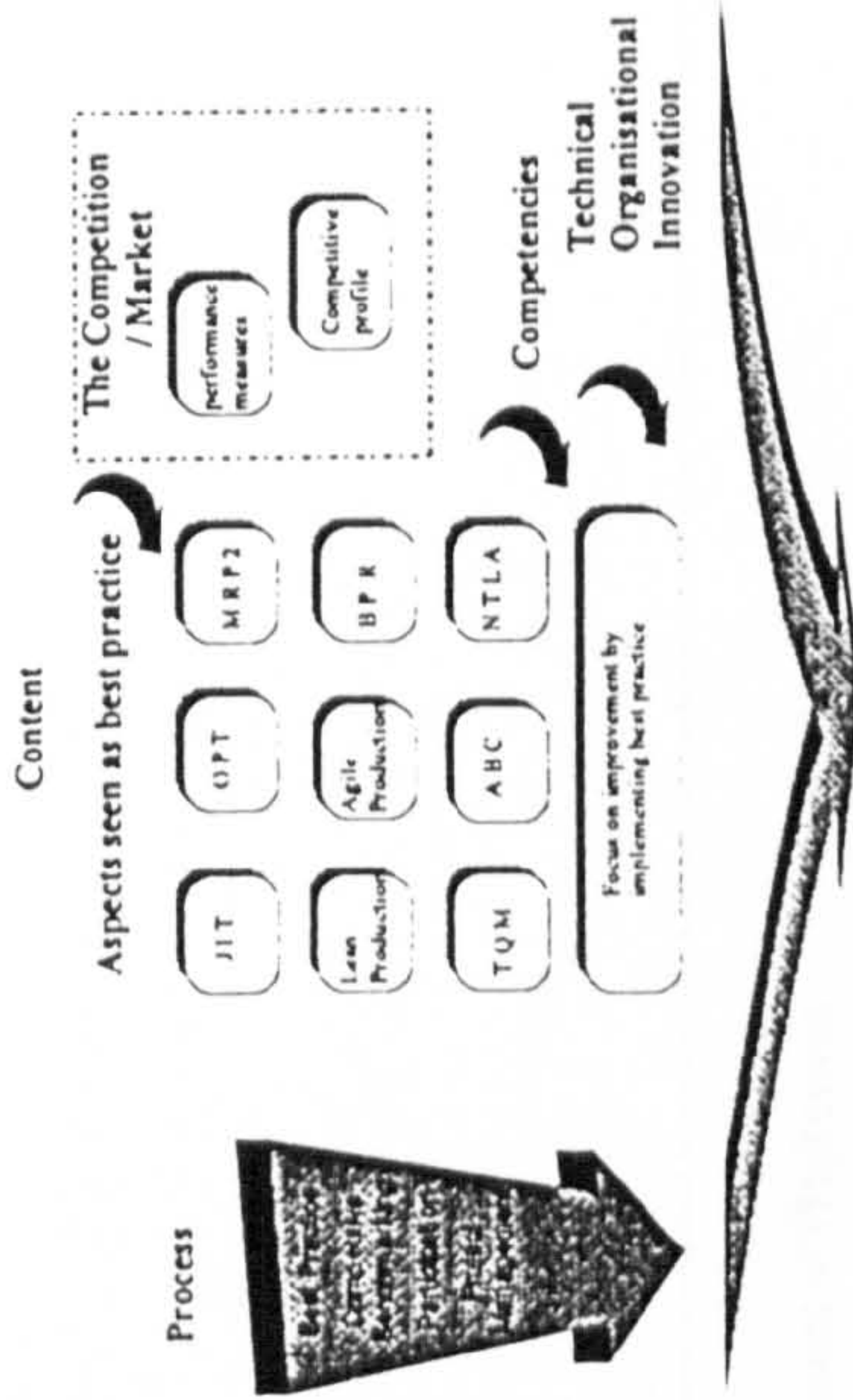

Manufacturing Strategy

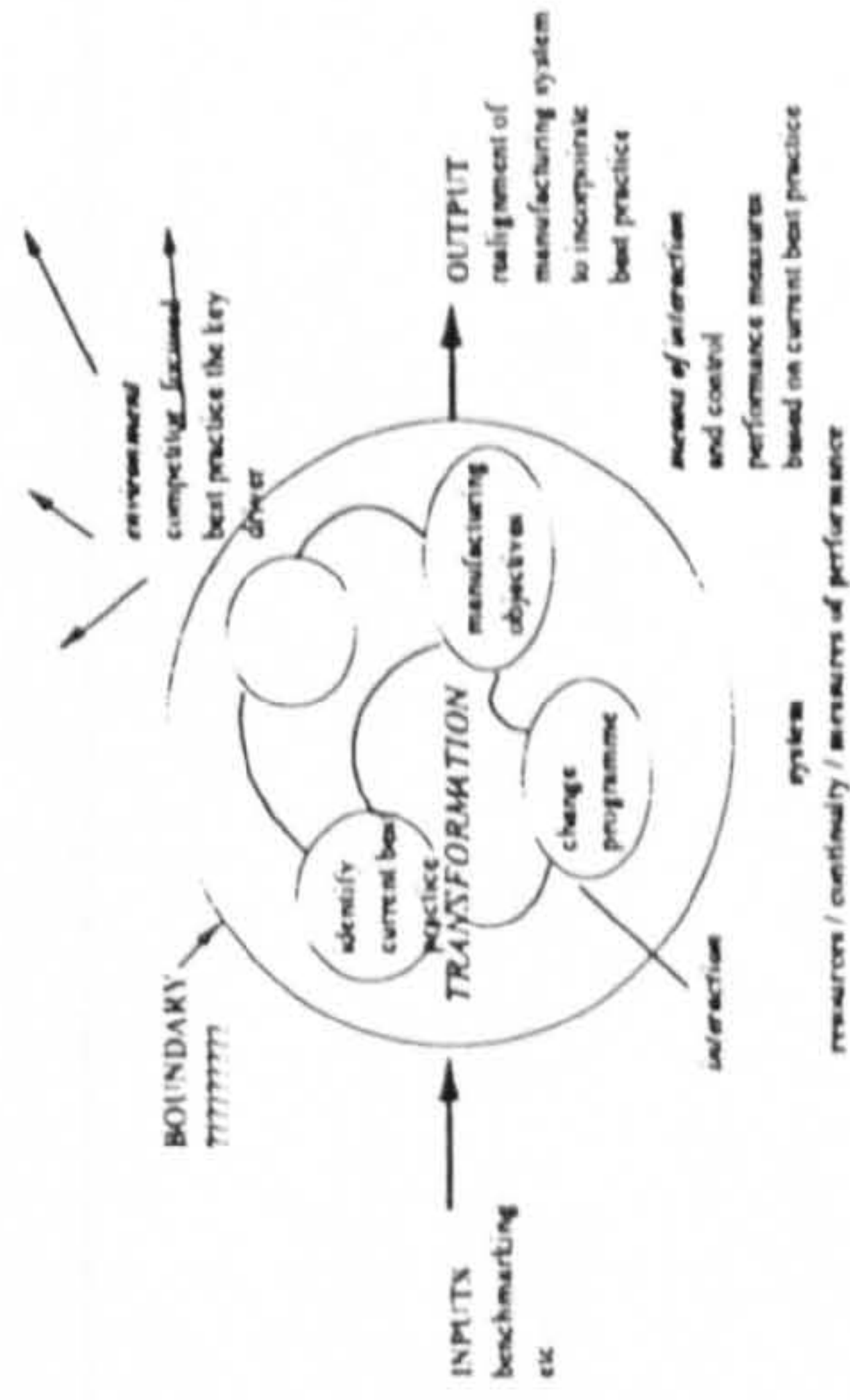

2.3.1.5.3 The knowledge based / learning organisation concept for Manufacturing Strategy

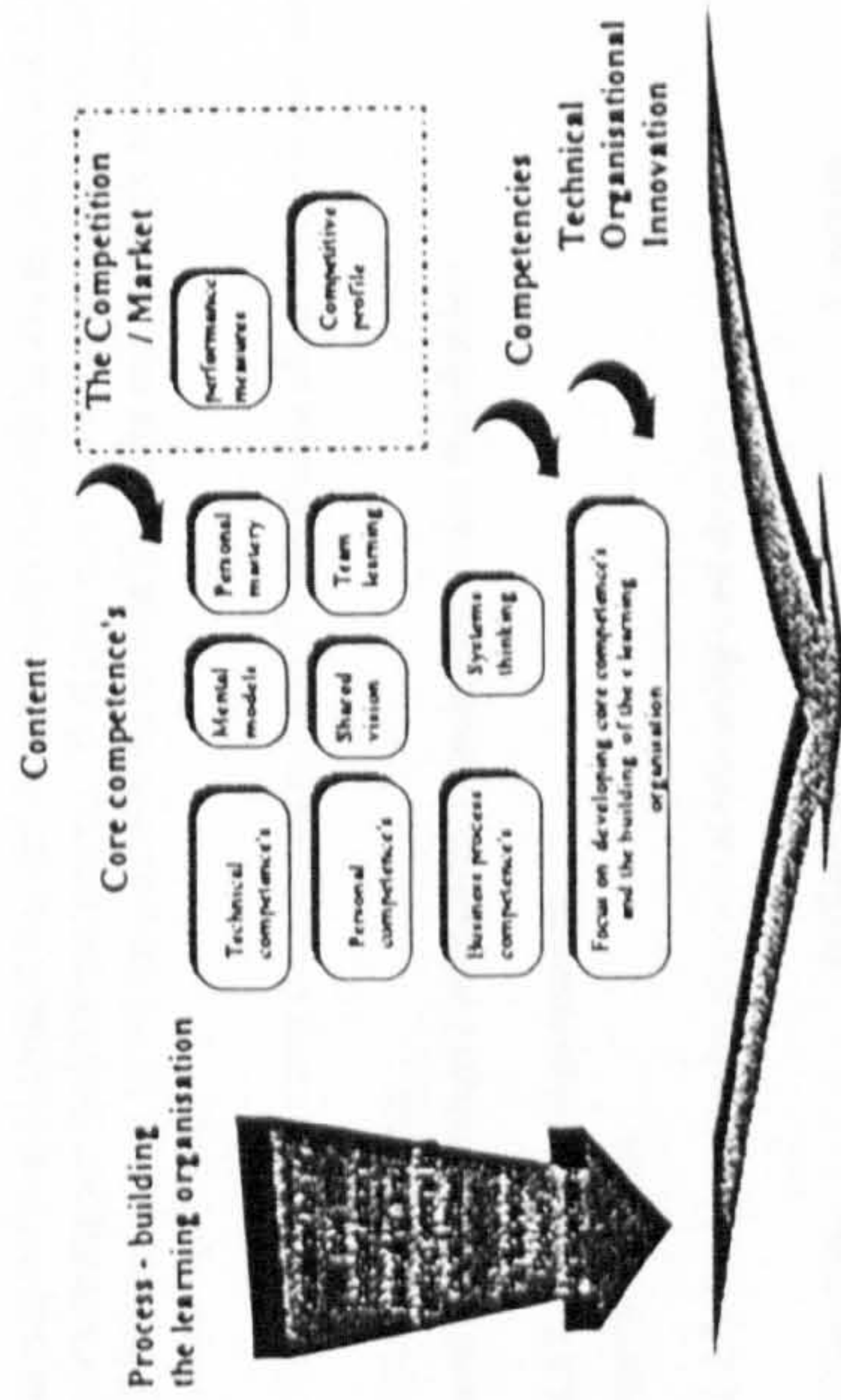

Manufacturing Strategy

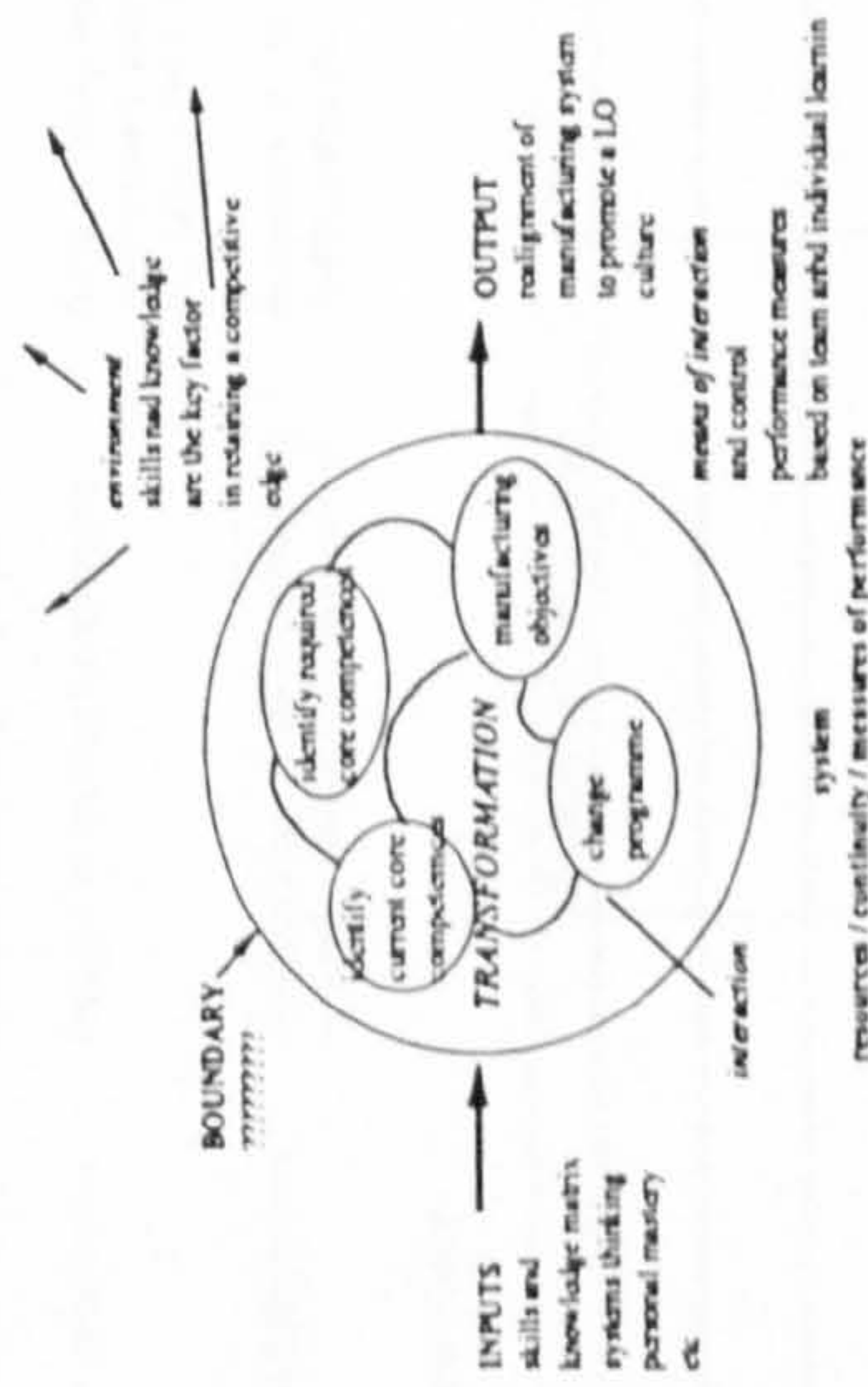

2.3.1.6 Develop statement of what the organisation expects of manufacturing.

Statement of what the organisation expects of manufacturing

2.3.2 Development of Objectives

After developing a statement for manufacturing, several strategic objectives should be identified for manufacturing to aid in the selection of relevant systems. These objectives should be strategic in nature i.e. be stretch goals which support the business objectives and help steer manufacturing in the direction identified above.

Stretch Goals

2.3.3 Task 3.3 Identify manufacturing systems which will have a significant role in achieving or supporting the objectives identified earlier.

This task involves NAMING the individual systems that will be developed to enable the Manufacturing System to support the business strategy. This task looks at the systems within Manufacturing which will have an impact on the competitiveness of manufacturing and its ability to support corporate and business objectives.

In Soft Systems Thinking the relevant systems chosen can be either task or issue based.

2.3.3.1 Participants
Manufacturing Strategy Formulation Process Owner and stakeholders

2.3.3.2 Sources of Information
Organisation wide

2.3.3.3 Tools and techniques - brainstorming and description of systems

System type	Definition	Example
Human activity system	set of human activities which are carried in order to fulfil a given purpose	a business process
Designed physical system	designed by humans for a purpose	facilities, computer hard ware and software, machine tools, operating systems - CAPM, JIT, MRP, MRP2, OPT etc.
Designed abstract systems	developed by humans to represent 'the ordered products of the human mind'	procedures, policies, codes of conduct, quality policy etc.

Complete the table

System Type	Named Relevant System	Notes

2.3.4 What we have achieved by this stage

- Statement of the direction of manufacturing
- Statement of manufacturing objectives
- Statement of the stretch goals to achieve the objectives
- Systems identified which will enable manufacturing to achieve its strategy

Stage 4

2.4 The development of the root definitions for each relevant system selected in stage 3

The Road Map - Stage 4

Development of root definitions for each System identified as relevant to meeting the manufacturing objectives

'a system to do x by means of y in order to achieve z'

Customers

Actors

Transformation

World view

Owner

Environment

Objective

- to identify what each system should do and achieve in order to enable manufacturing to be competitive
- to make the thinking explicit for each relevant system - a root definition is developed for each world view held by the stakeholders within the manufacturing strategy formulation process

Desirable

- a root definition for each chosen relevant system and for each different point of view held about that system

2.4.1 Task 4.1 Develop root definition for what you want your relevant systems to achieve in terms of supporting the manufacturing objectives identified previously.

2.4.1.1 Participants

Manufacturing Strategy Formulation Process Owner and team

2.4.1.2 Sources of Information

Organisation wide

2.4.1.3 Tools and techniques

After naming any relevant systems it is important to formalise your thinking by using systems concepts. This is done by carefully describing the system as a root definition using the mnemonic CATWOE. All the elements of the systems should contribute to the root definition therefore this stage requires a lot of thought.

The basic form of the root definition is

A system
: to do X
:by means of Y
:in order to achieve Z

The concept of a system and the reasoning behind developing root definitions is to capture the main elements involved in that system. The mnemonic CATWOE is used to develop the root definition and to expose the Weltanschauung [world view] held within that RD.

Customers: • direct victims or beneficiaries - people or systems which are associated with the inputs and the outputs of the system

Actors: • person who carries out one or more activities within the system, can also be extended to cover other resources which are crucial to the operability of the system

Transformation: • fundamental concept of converting some input into some output this is the transformations focused on purposeful action - i.e. organised activities which brings about some sort of change

Worldview • the view of the world which makes the human activity system and particular root definition of the relevant systems meaningful
• an activity model is an ideal representation of one particular view of some purposeful action

Owner: • person, system or agency which has the power to control and ultimately abolish the system under consideration

Environment: • constraints imposed on the system by the environment

2.4.1.4 An Example of a Root Definition - Just In Time

NB: JIT has also been called Continuous Flow Manufacturing [IBM], Time Based Competitiveness [Boston Consulting Group], Synchronous Manufacture

A system to eliminate waste and delays at every stage of the supply chain, by means of scheduling inventory to be available at the latest possible time which will not cause any delay in order to achieve excellence.

Customers: Operators, external customer

Actors: Suppliers, operators

Transformation: Scheduling of information, delivery of components and product

World view: Flexibility, low waste and flow production is a good way to manage the manufacturing operation and the supply chain

Owner: Supply Chain Manager

Environment: Competitive environment

Concepts of Just In Time [JIT]

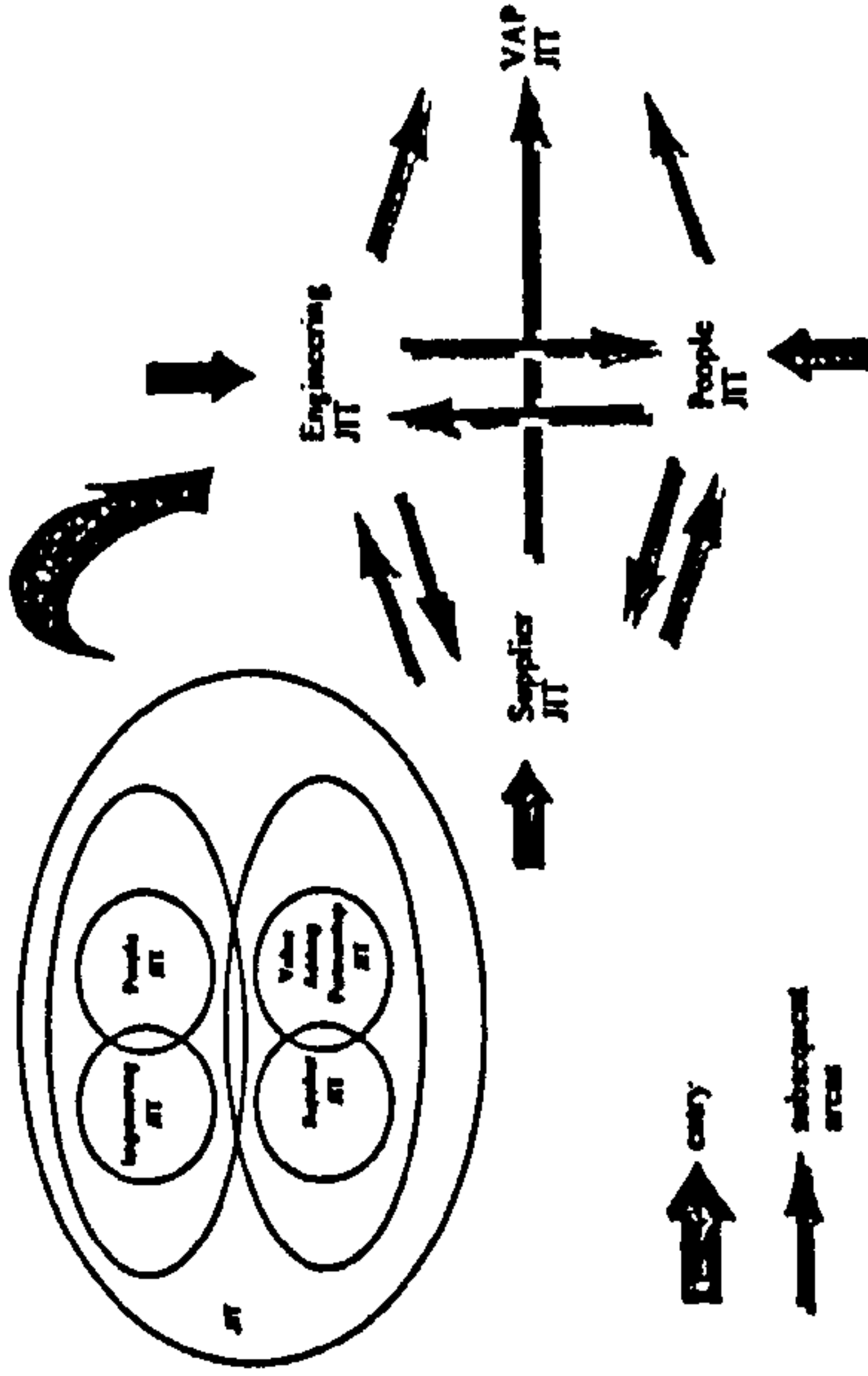

Richard J. 'Implementing JIT' IFS Publications 1991

2.4.1.5 Template for developing a root definition and system concept for each named relevant system

Relevant System:

A system to do

by means of

in order to achieve

Customers:	
Actors:	
Transformation:	
Weltanschauung:	
Owners:	
Environment:	

Draw System Concept here

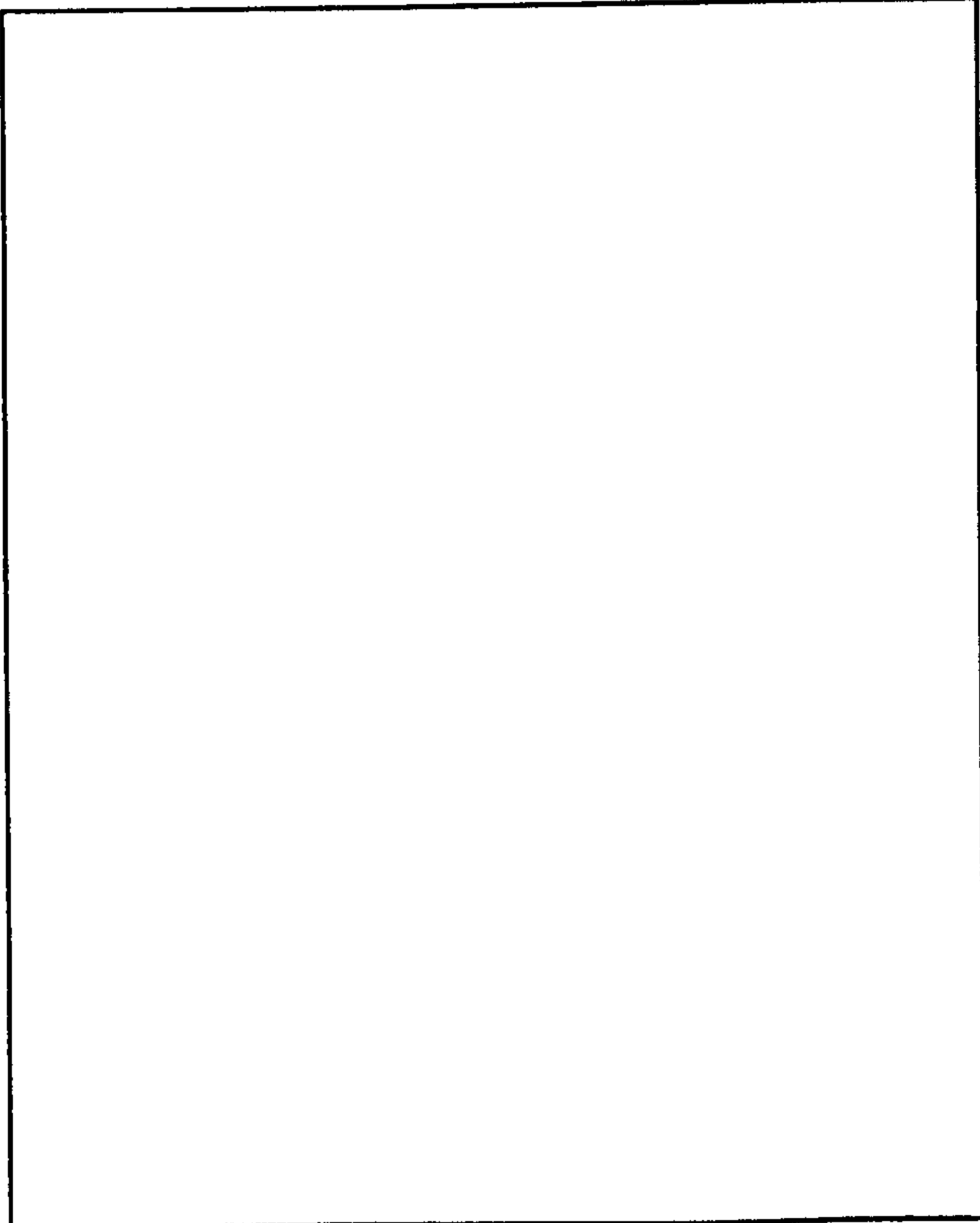

Stage 5

2.5 The development of conceptual models derived from the root definitions from each relevant system

The Road Map - Stage 5

Objective

- to develop conceptual models to satisfy the root definitions developed in stage 4

Conceptual Models



Deliverable

- develop conceptual models from the root definitions using systems concepts

2.5.1 Task 5.1 develop conceptual models of the chosen relevant systems using the root definitions and systems concepts developed in Stage 4

Keep the conceptual models at a high level. When feasible and systemically desirable changes have been identified detailed modelling can be done at the implementation stage.

Conceptual Models - what they are and how they can be used

Definition of a conceptual model: a conceptual model is a set of constructs used to help to make a situation more clearly understood. Conceptual models can range from formal modelling methods such as IDEFo to using mind maps to convey key concepts and ideas. Depending on the complexity of the Manufacturing Systems named earlier - will depend on the conceptual model developed. Using systems thinking the following parameters should be determined and developed for each relevant system chosen and each weltenschauung exposed.

2.5.1.1 Template for gathering information for the conceptual models

Named relevant system:	
Root definition:	A system to do _____ by means of _____ in order to achieve _____
C	
A	
T	
W	
O	
E	

The relationship between external and internal variables and the properties of a system can be termed the parameters of a system. Parameters can be categorised as;

System Level 0-1 [it is recommended that 5 - 7 activities are used at any one level. Systems can be explained in terms of hierarchies which enable the more complicated systems to be decomposed at certain level to ensure they are manageable.

Sources	Inputs	Processes	Transformation	Outputs	Receivers	Feedback

System Level 1

Sources	Inputs	Processes	Transformations	Outputs	Receivers	Feedback

System Level 1.1

Sources	Inputs	Processes	Transformations	Outputs	Receivers	Feedback

2.5.1.2 Description of Parameters

1. Sources

When considering a manufacturing system there can be many alternative sources for each input. For example sub component suppliers, raw material sources, consultants etc.

2. Inputs (Resources)

Inputs to the manufacturing system are only as good as the available resources. Inputs can be sub-divided into the basic inputs and complementary inputs. Basic inputs comprise of the goods and services required to produce the basic output and complementary inputs that are resources and constraints that support and control the system.

3. Processes and Transformations

Processes and transformations are the sequences of activities that take place within a system to transform the inputs to the system into outputs.

4. Outputs

Anything exported from a system into its environment is an output. Outputs may take the form of energy, waste, chemicals, information, products etc.

The term "throughput" is often used to encompass all the flows through a system.

5. Receivers

Outputs of a system can be transferred to the receivers. The value of the output from the system can be determined by the value of that output to the receivers. If the output of a manufacturing system is a finished product then the product should meet the needs of the customer.

6. Feedback

Feedback is the function of the system that compares the output of the system with given criterion in order to reduce the deviation between the actual output and the desired output. Feedback can be divided into two different types, intrinsic and extrinsic feedback. Intrinsic feedback involves when the feedback and the control system exist within the system's boundary. Extrinsic feedback involves feedback and control that exists outside the boundaries of the system.

Modelling techniques to consider: Process flows, IDEFo, SSADM, Brown paper with post it notes etc.

An IDEF_o model provides a complete, concise and consistent description of the activities and flows that form a system or process. The model is developed from a particular viewpoint for a particular purpose.

The structure of a model

Each model consists of up to five main parts:

- Node index
- Context diagram
- Activity diagrams
- For Exposition Only (FEO) diagrams
- Glossary

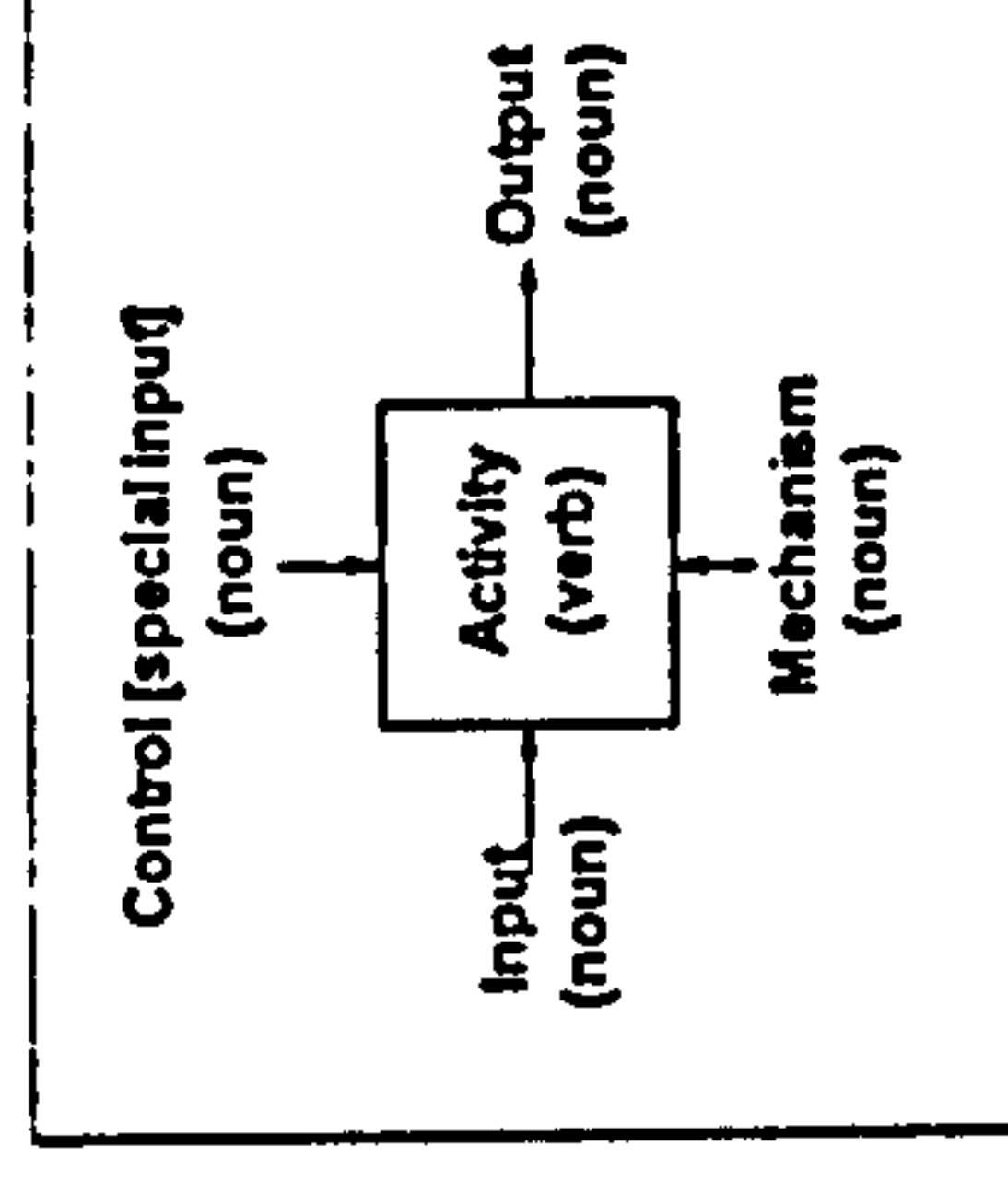

example of IDEFo - useful for conceptual modelling

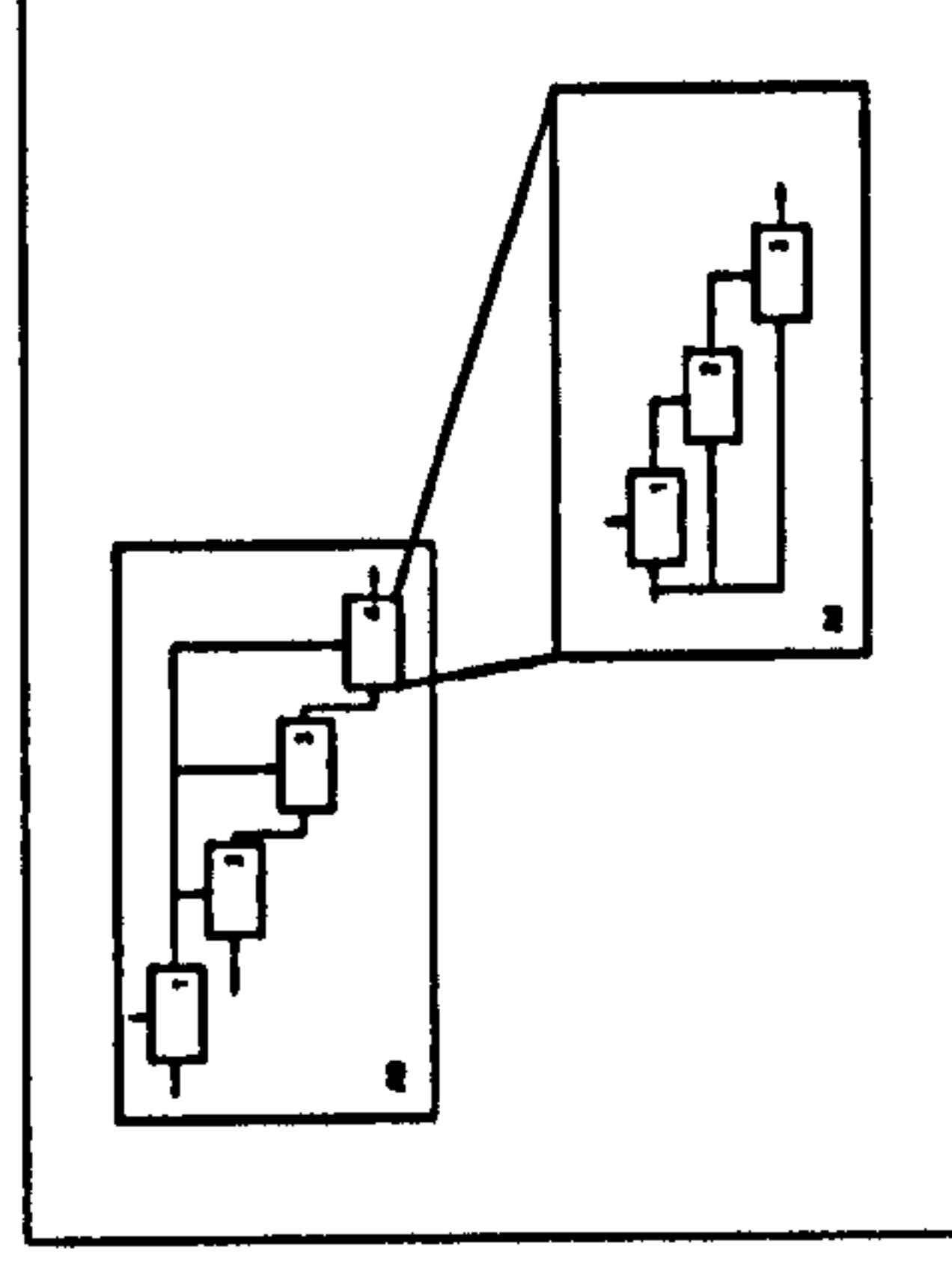

Stage 6

2.6 The comparison of the conceptual models and the real world situation.

The Road Map - Stage 6

Objective

- to compare the conceptual models derived from the root definitions with the real world situation to provide a set of strategic issues that need to be addressed to enable manufacturing to support business and corporate objectives.

identification of differences between conceptual models and the real world

Deliverable

- Completion of comparison tables

2.6.1 Task 6.1 Complete Comparison Table/s

2.6.1.1 Participants

Manufacturing Strategy Formulation Process Owner and stakeholders

2.6.1.2 Sources of Information

Conceptual models
Rich Picture Questionnaire
Rich Picture

Current process models
Current organisational documents

2.6.1.3 Tools and techniques - Example of a comparison table

A matrix for comparing a conceptual model with a real world situation [p 42 Checkland]1990

Activity / from conceptual model/	Exists or not in real situation?	How is it done?	How is it judged?	Goals
1			criteria and current judgement	new 'what's alternative hows ideas about changes
2				
3				
Links				
Activity and links from models e.g. 1 - 2 2 & 3 - 4				

Questions to ask:

- Does this activity, or this relationship, exist in some time?
- How is it done and by whom?
- Is it a source of concern or is it regarded as well done?

Stage 7

2.7 Identification of feasible and desirable changes to the Manufacturing Strategy System - output the direction and journey of the Manufacturing System - The Manufacturing Strategy

The Road Map - Stage 7

Objectives

- to provide an implementable manufacturing strategy which will support business and corporate objectives and is systemically and culturally desirable and feasible.

Deliverables

- Strategic goals
- Strategic plan to achieve the goals

Changes Systemically desirable
Culturally feasible to
manufacturing

2.7.1 Task 7.1

Using the comparison results from stage 6 debate the strategic changes which could be introduced into manufacturing taking into consideration the current Manufacturing Strategy archetype your organisation is currently in and whether the current archetype is suitable for the corporate and business strategy.

Agree 'culturally desirable and systemically feasible' changes following the debate.

2.7.2 Task 7.2

Develop an action plan to ensure all changes are implemented appropriately. [This will depend on your organisations culture, history, employee relations etc.]

the action plan should include:

- stretch goals - manufacturing objectives identified timescales
- resources allocated and required
- implementation process owner and Manufacturing Strategy champion identified

Goal	Link to Manufacturing Strategy	Timescale	Resources	Responsibility	Team Members

Implementation

2.8 Some notes for implementation

Most organisations are brilliant at coming up with good ideas which could benefit them enormously. It appears that the implementation stage is where a great deal of good work is wasted. Several factors have been identified as to why implementations fail.

- Lack of management commitment
- Lack of understanding by the different stakeholders of what is trying to be achieved
- Under resourced teams
- Lip service by Management
- No process champion

Hopefully the workbook has addressed some of these issues

Section 3

3. Section 3 - Additional Information

3.1 Glossary of terms [taken from Checkland 1991]

SSM epistemology	the language through which its process makes sense
Real World	'the unfolding interacting flux of events and ideas experienced as everyday life'
Systems Thinking World	'the world in which conscious reflection on the 'real world' using systems ideas takes place'
Problem Situation	'a real - word situation in which there is a sense of unease, a feeling that things could be better, or some perceived problem requiring attention'
Rich Pictures	'pictorial / diagrammatic representation of the situations entities [structures], processes, relationships and issues]'
Root Definitions	'concise verbal descriptions expressing the nature of purposeful activity systems regarded as relevant to exploring the problem situation. I.e. a system to do x by means of y in order to achieve z.'
CATWOE	MNEMONIC to describe elements considered in the formulation of root definitions
The 5Es	criteria by which T is judged - efficacy [does the means work?], efficiency [are minimum resources used?], effectiveness [does the T help the attainment of longer goals related to the owners expectations?], Ethicality [is T a moral thing to do?], elegance [is T aesthetically pleasing?]
Conceptual Model	structured set of activities necessary to realise the root definition and CATWOE, consisting of an operational subsystem and a monitoring and

Comparison

control subsystem based on the Es
setting the conceptual models against the perceived real world in order to generate debate about perceptions of it and changes to it which could be regarded as beneficial.

Desirable and feasible changes

possible changes which are systemically desirable on the basis of the learned relevance of the relevant systems, and culturally feasible for the people in the situation at this time

Action

real world action to improve the problem situation as a result of operation of the learning cycle for which this epistemology provide as a language

Section 4

4. Analysis of results - Feedback of process of Manufacturing Strategy Formulation Process using modified Soft Systems Methods.

Please take a few minutes to complete this final questionnaire to help with the development of the workbook approach to the Manufacturing Strategy Formulation Process using the Soft Systems Methodology.

Did you find the workbook:

- Useful
- Difficult to follow
- Required facilitation
- Too time consuming
- Helpful
- Complete
- Other

The result of the Manufacturing Strategy Formulation Process was

- An implementable Manufacturing Strategy Agree Disagree Don't Know
- A useful learning experience
- Confused
- A focusing of ideas
- Difficult to follow

The format of the workbook was

- User friendly Agree Disagree Don't Know

Please add any other comments below:

Section 5

5. Process Model of the flow of the methodology.

The following model has been developed using BPW/in and IDEFo notation. The process model can be used as a check sheet as the team moves through the workbook, and can be used initially to explain the process to the Manufacturing Strategy Formulation Process owner and key stakeholders.

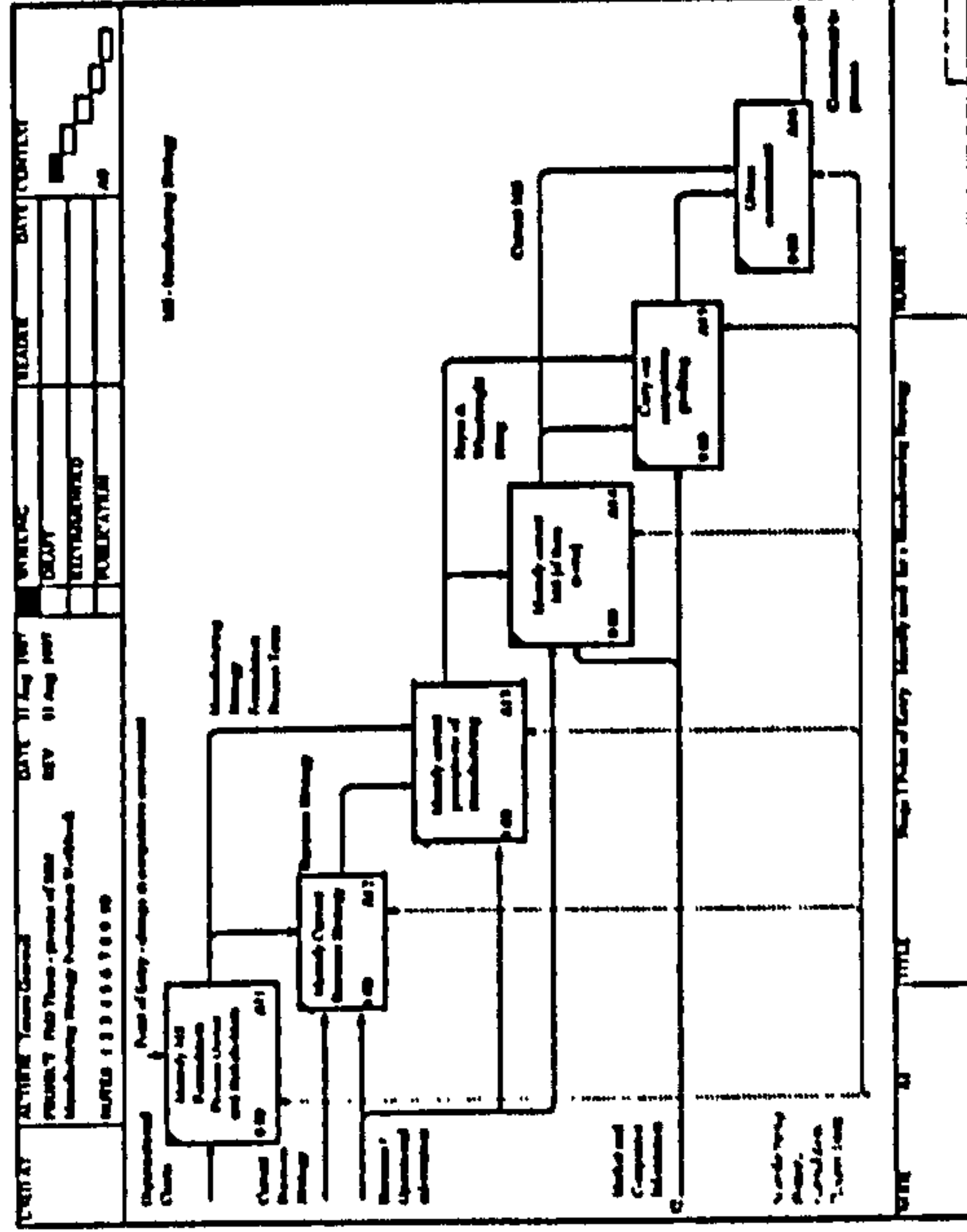
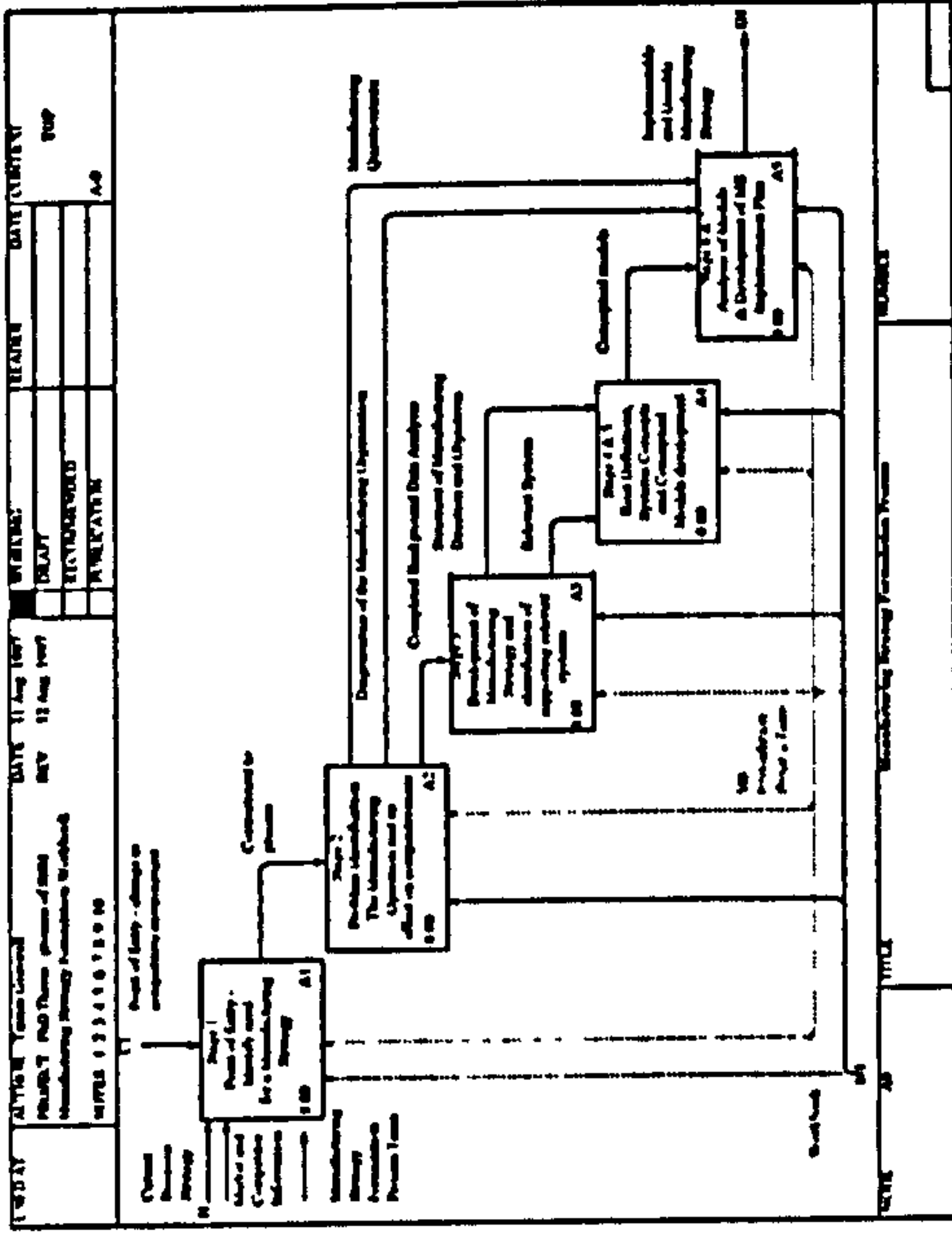
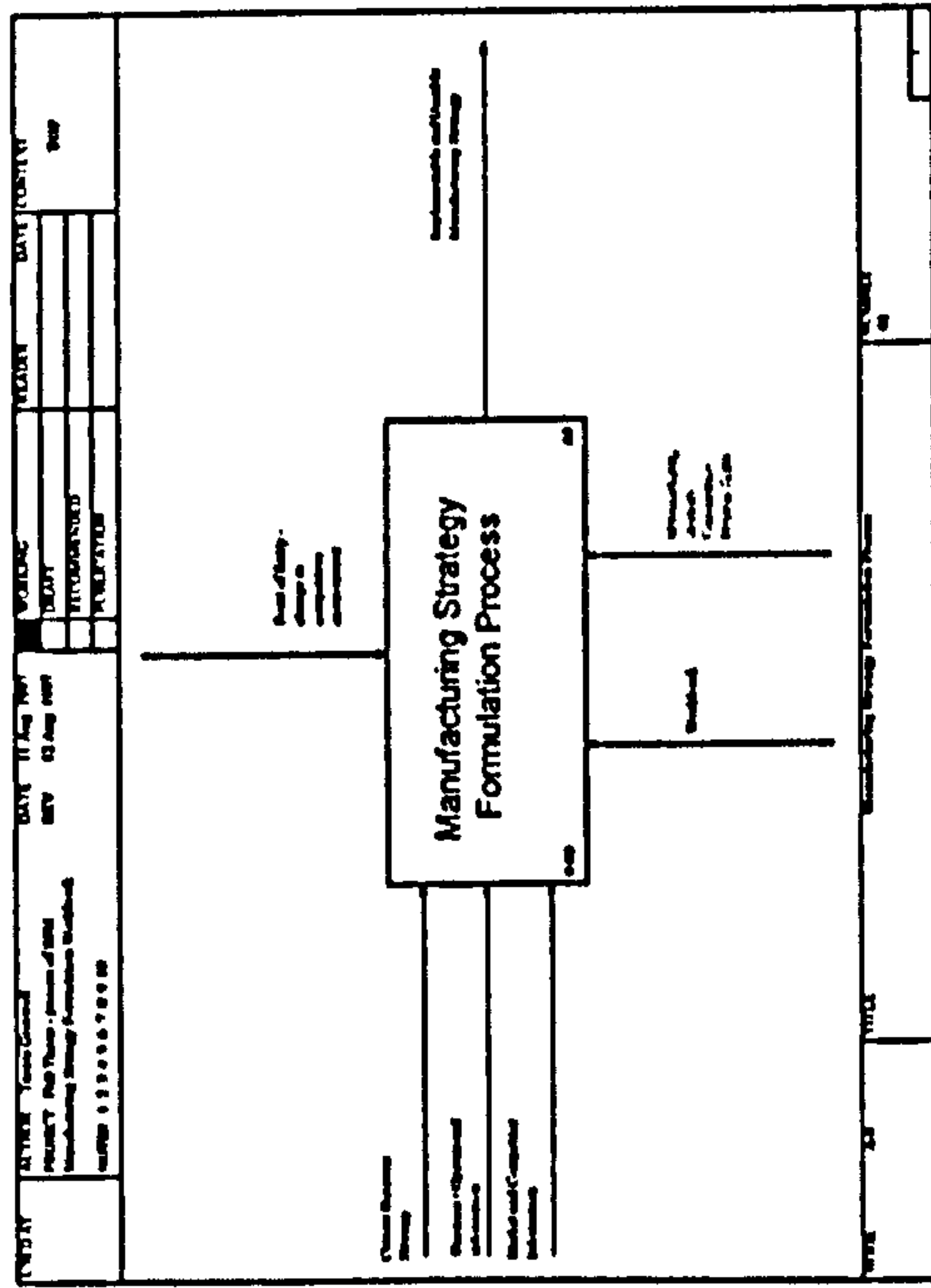

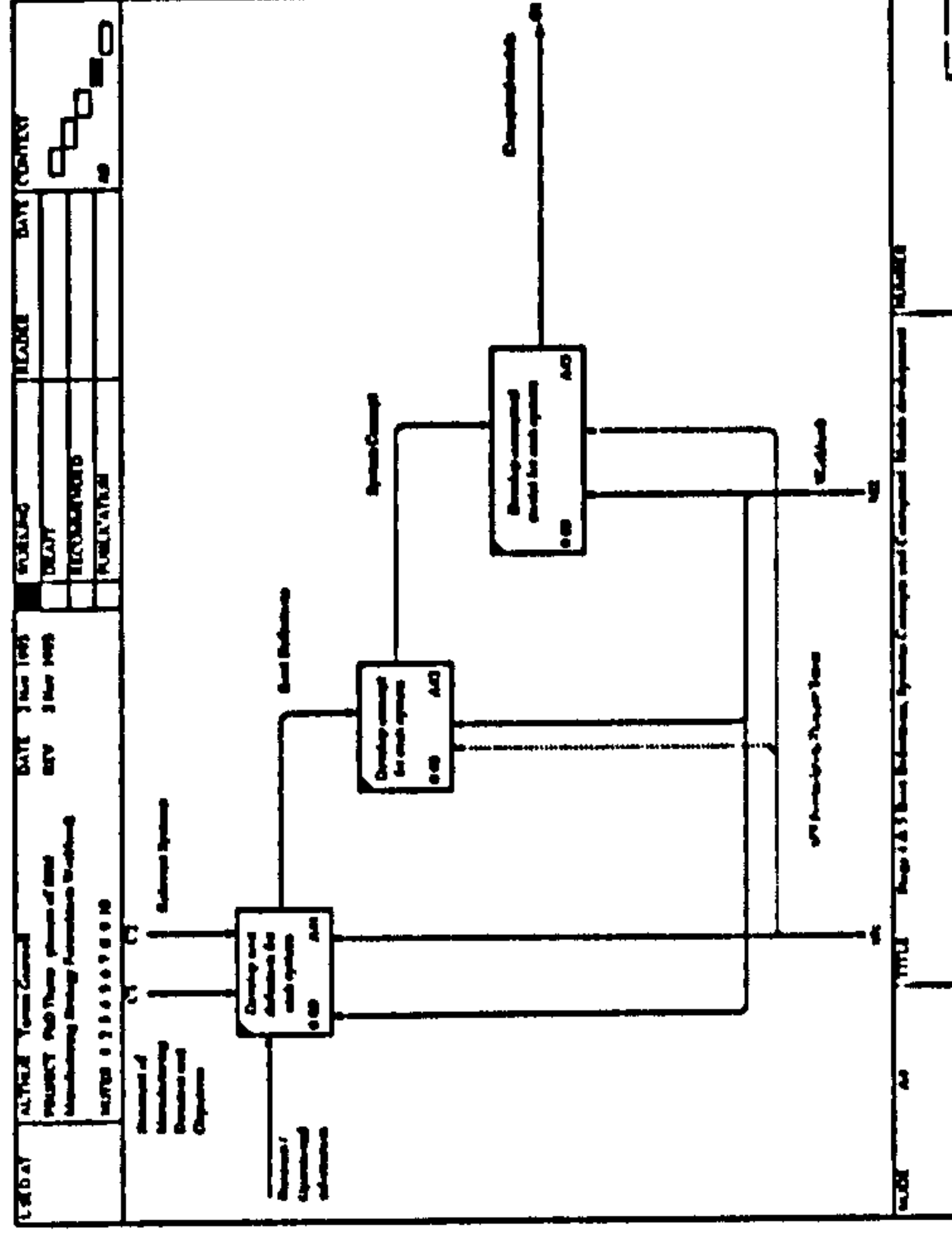
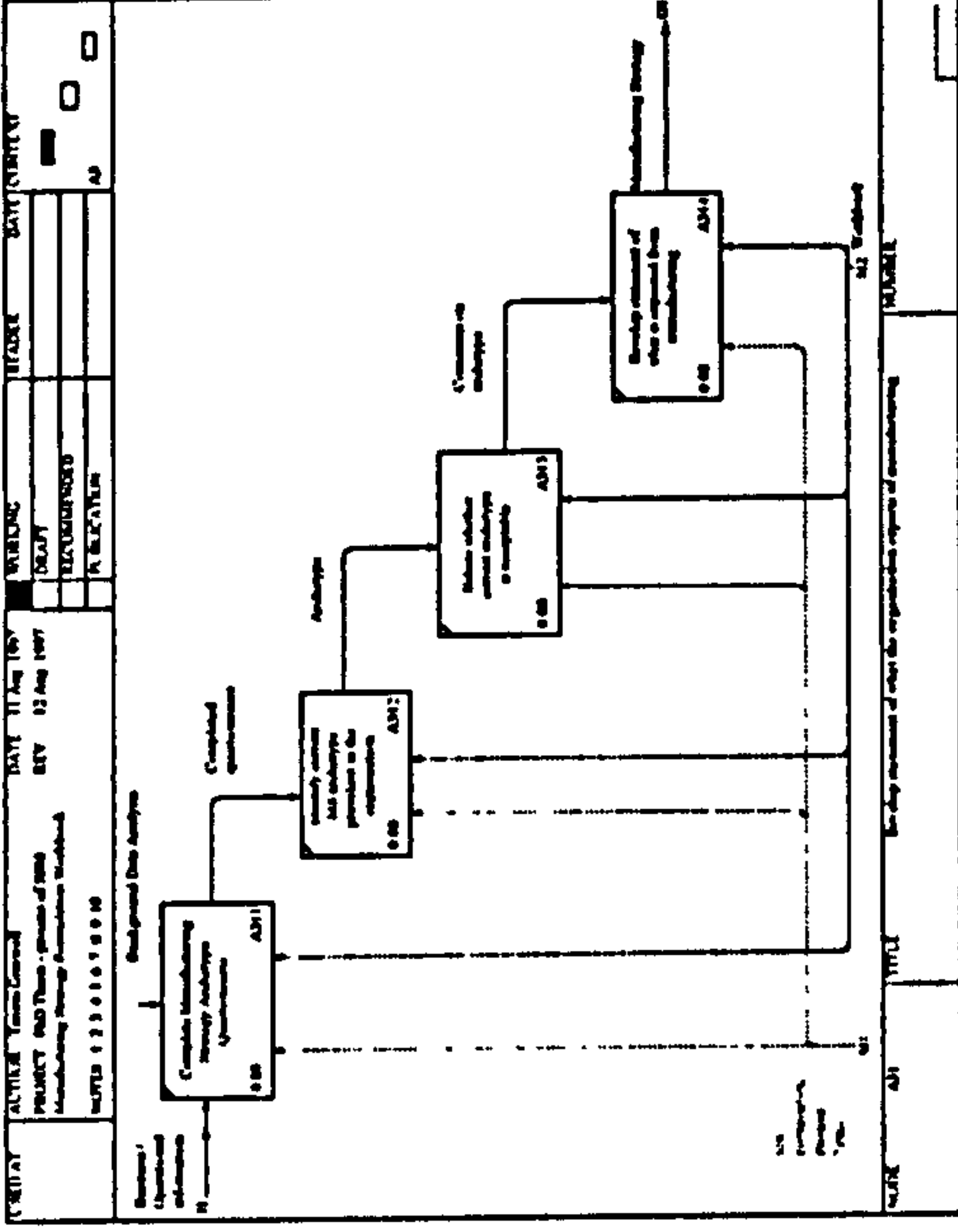
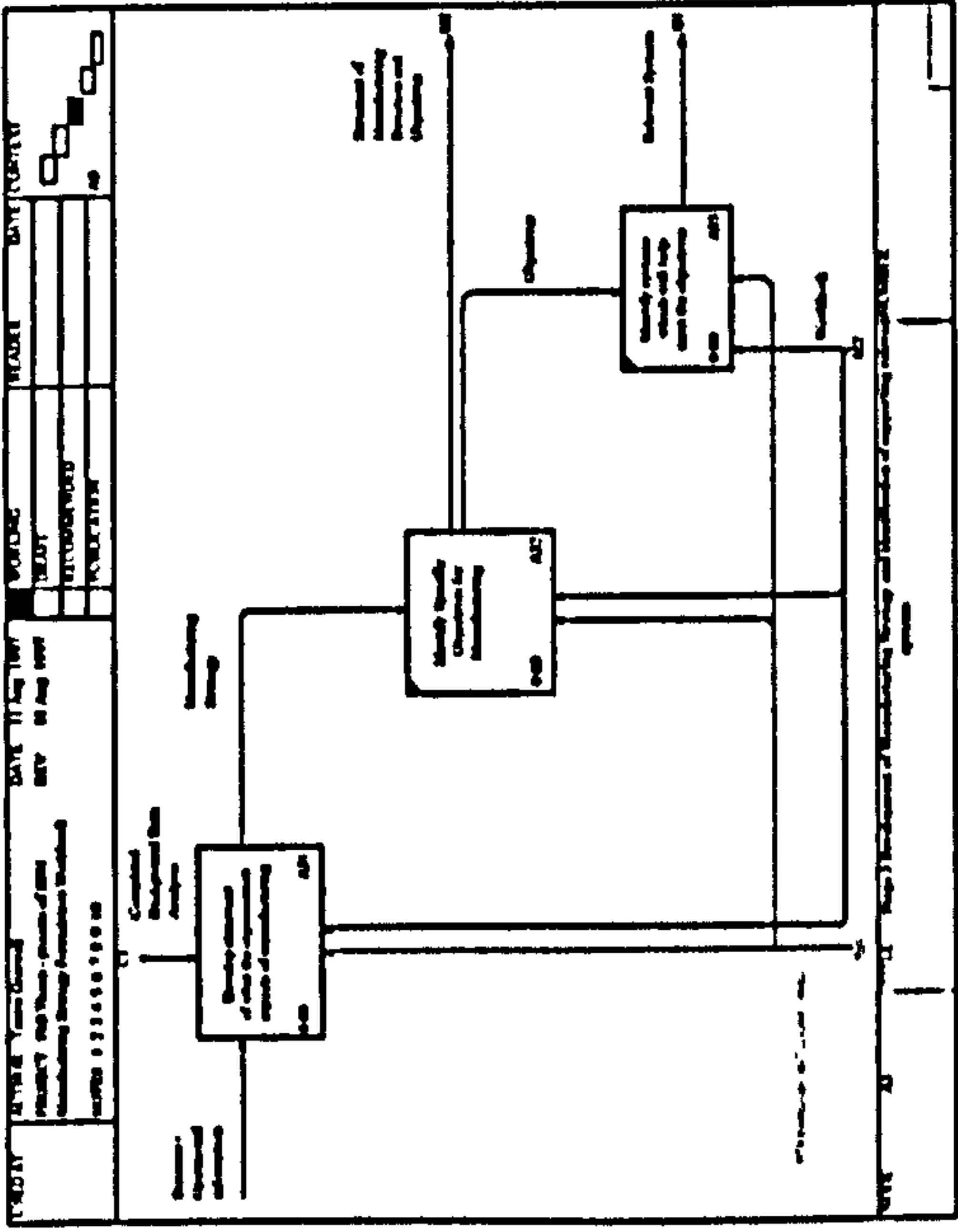
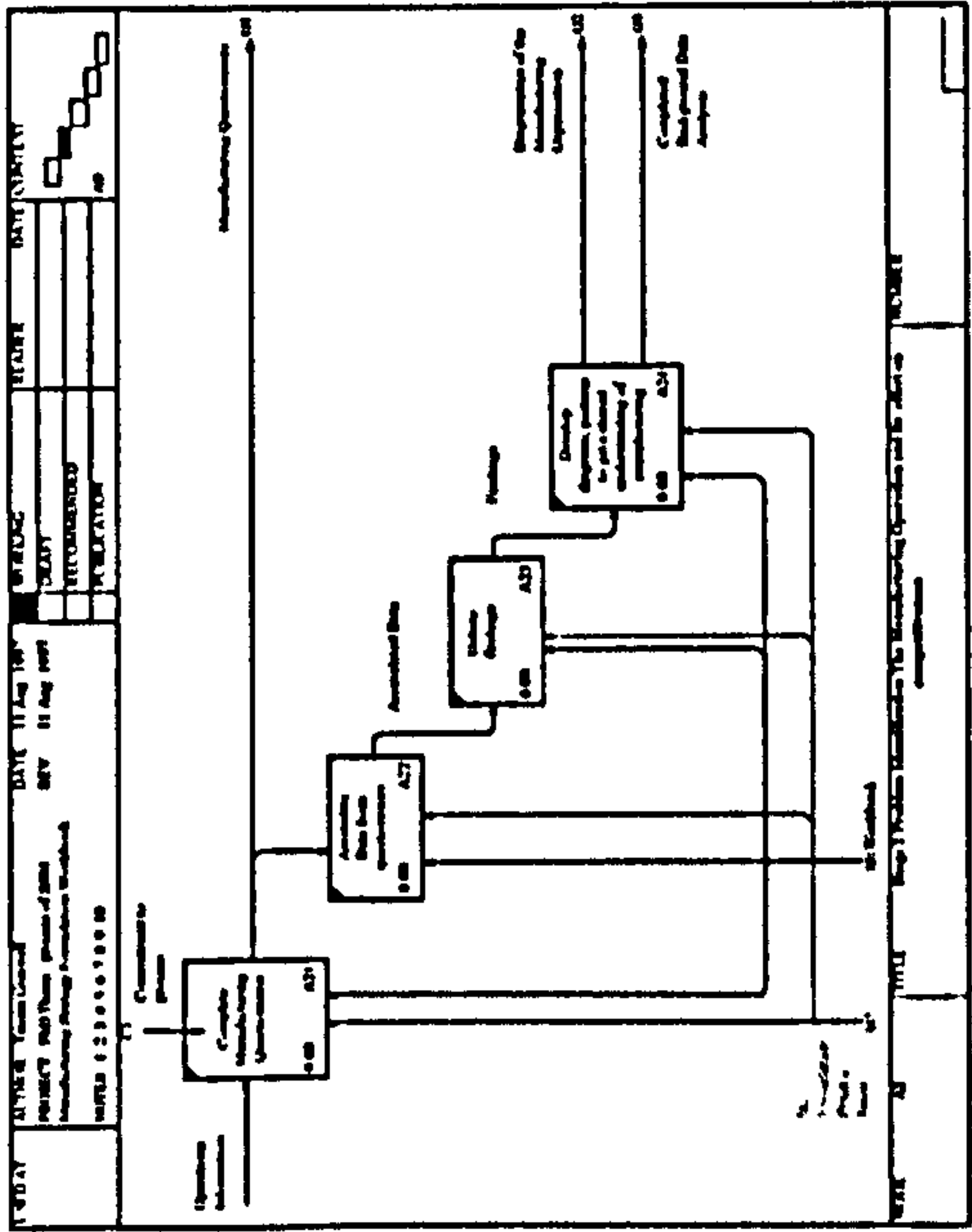

**Appendix Four – validation of the modified approach to the
formulation of a manufacturing strategy**

Case L

Case M

Case N

Additional comments from academics

1.1. Case L

The validation carried out with Case L was gathered from workshops and meetings between June and October 1997

1.1.1. Participants

Chief engineer
Head of research and development
The researcher

The data was validated by the participants who read the reports for each meeting provided feedback and signatures.

1.2. Validation approach

The participants were led through the approach by the author, stage by stage. The purpose for this was to ensure the approach was applicable to practitioners so that the approach was logical, provided a means for debate, exposed different worldviews, and ensured the sequence of events was correct.

At each stage, the objectives, deliverables and activities were talked through and debated by the participants. Several points provided some query by the practitioners which were addressed by the author and validated by the practitioners. These points can be found in the supporting documentation but included

- Stage 1 – does the organisation see the need for change? – commitment required rather than a plan at this stage
- Hayes and Wheelwright (1984) model ‘needs to be pulled out as a separate entity – expand to include a matrix or a checklist to enable the participants to see where the manufacturing sits within the organisation’
- Questionnaire – needs to be split into two bits, the identification of the business strategy and the identification of the current manufacturing situation.

The overall comments included ‘enthusiastic about the process’ ‘see the relevance of using soft systems theory in the manufacturing strategy formulation process.

- The next stage of the validation consisted of moving through the approach. The comments received by the practitioners were extremely useful and included:
 - A facilitators guide would be useful to enable the process to take place without the researcher
 - They would use the workbook to its full, but were not sure when this would occur

- The approach was seen as useful
- The background theory at the front of the workbook was relevant and at the right level

The workbooks' applicability was wider than the aerospace industry

A final comment 'it was useful to focus on the general business issues and manufacturing issues develop the understanding of how the manufacturing strategy should evolve'.

4.1 Validation comments

Development of the Workbook for Soft Systems Approach to the formulation of a Manufacturing Strategy

Date	Thursday 19th June 1997
Location	Case Company L ..
Participants	Chief Engineer Head of Research and Development Researcher
Time	1.30 - 3.30

Report

The workbook was introduced by TG, overall the response was enthusiastic to the ideas and structure of the workbook. It was agreed to meet in 2 weeks to complete the first pass of the workbook and to develop the workbook further for introduction to the Manufacturing Strategy formulation process.

The following comments were made and will be incorporated into the workbook as part of the development. These meetings are seen as part of the validation of the research i.e. to make the research output applicable and useable to practitioners.

The comments address several different aspects of the workbook including the following:

- layout
- story board and dependencies
- sequence of events
- typeface
- language used

Overall comments

- enthusiastic about the process
- saw the relevance of using soft systems theory in the Manufacturing Strategy formulation process

Real world problem situation

No	Heading	Items to Change/comments
1.3	The road map	the 'situation - corporate and business strategy - focus on manufacturing move over the top
1.5	Issues to be considered	<i>additional points to consider</i> what is the best practise for this process, what is the rest of the world doing, who want this to happen, what can't be changed - paradigms? how do we build confidence, who benefits from the process, who can you learn from, where can you go to stop inventing the wheel
2.1	Stage 1	title - does the organisation see the need for change? Commitment required rather than a plan at this stage - aimed at would be improvers of the situation/ <i>the level is right - i.e. who we are aiming at in this stage</i>
2.1.1	Task 1.1	change type face on text. <i>need to make it clear that we are assuming that question - key manufacturing stakeholders</i> sources of info current strategy and policies, existing business objectives
2.1.2	Task 1.2	explicitly say what the business strategy is. Add policies to sources of information <i>general place to address business strategy</i>
2.1.3	Manufacturing Strategy	needs to be pulled out as a separate entity - expand to include a matrix or checklist to enable the participants to see where manufacturing sits within the organisation Can then be used as a baseline for the rest of the work book. Also be used as a source of debate
2.1.4	Competitive profiling	need an explicit statement of what the current manufacturing strategy is [whether it is emergent or not] whether it is explicitly stated or not. need a degree of facilitation at this stage expand this stage - show them what they are supposed to do - needs more of a structure. Also add references - additional material, DTI book to aid understanding need some analysis to trigger the next stage i.e. to get the stakeholders to see the need of the Manufacturing Strategy formulation process. <i>Need to realise that there is a problem situation - need an explicit statement of that problem - this is all about identifying the need for a Manufacturing Strategy and gaining commitment to the rest of the process</i>
2.2	Stage 2	need a statement about what a rich picture is - all about gaining greater understanding of what manufacturing is all about and how it can help support business objectives
2.2.1	Questionnaire	split into two bits - identification of the current business strategy - more detail than just the statement required in stage 1 identification of the current manufacturing situation need questions to ask at the end of the questionnaire about trade offs etc. RIG QUESTION - what are we going to do with all the information - generate charts - generate material which can be presented to the stakeholders to show the need for change and continuing the process.
2.2.2	Development of rich picture	needs more thinking about - Mindmaps????? - difficult

End of stage 2	put to one side - for use later when we are comparing the 'as is' with the 'what we actually want'
----------------	--

Systems World

2.3	Stage 3	need to state what we want our new Manufacturing Strategy to do - before we name the relevant systems which will be defined to help us to achieve our objectives - use the business questionnaire results make a distinction between the 'systems world' and the real world situation
		need direct examples of relevant systems in Manufacturing we are focusing at each stage
2.3.1	Task 3.1	need a template for this bit - i.e. naming of relevant systems within manufacturing to help support business objectives and the new Manufacturing Strategy
2.4	Stage 4	developing the root definitions for each relevant system - the W should be implied by the facilitator - "conditioned to our own 'back garden view'" - some back gardens may be bigger than others give a structure on how a debate should be developed from the root definitions <i>all elements of the root definition must contribute to the Manufacturing Strategy</i> more examples of root definitions for each relevant systems identified change RD for Customer focused approach to Manufacturing Strategy formulation remove information on systems concepts and emergent properties - systems analyst will already know about these aspects and others wont really want to know.
2.4.1.5	Template	helpful
2.5	Stage 5	development of conceptual models - mention hierarchies - numbering systems used and decomposition 5-7 activities or processes examples of IDEF0 alternative routes through the process
2.6	Stage 6	bringing real world and systems world together - need to think very carefully about the words used and who it is aimed at. What does 'stakeholder' actually mean?? Need to recognise that its not all blue sky stuff - should be able to involve the shop floor as well.

Or. Bell

	put to one side - for use later when we are comparing the 'as is' with the 'what we actually want'
--	--

Systems World

2.3	Stage 3	need to state what we want our new Manufacturing Strategy to do - before we name the relevant systems which will be defined to help us to achieve our objectives - use the business questionnaire results make a distinction between the 'systems world' and the real world situation
2.3.1	Task 3.1	need direct examples of relevant systems in Manufacturing we are focusing at each stage need a template for this bit - i.e. naming of relevant systems within manufacturing to help support business objectives and the new Manufacturing Strategy
2.4	Stage 4	developing the root definitions for each relevant system - the W should be implied by the facilitator - "conditioned to our own 'back garden view" - 'some back gardens may be bigger than others' give a structure on how a debate should be developed from the root definitions <i>all elements of the root definition must contribute to the Manufacturing Strategy</i> more examples of root definitions for each relevant systems identified change RD for Customer focused approach to Manufacturing Strategy formulation remove information on systems concepts and emergent properties - systems analyst will already know about these aspects and others wont really want to know.
2.4.1.5	Template	helpful
2.5	Stage 5	development of conceptual models - mention hierarchies - numbering systems used and decomposition 5-7 activities or processes examples of IDEFO alternative routes through the process
2.6	Stage 6	bringing real world and systems world together - need to think very carefully about the words used and who it is aimed at. What does 'stakeholder' actually mean?? Need to recognise that its not all blue sky stuff - should be able to involve the shop floor as well.

Or. Bell

End of stage 2	put to one side - for use later when we are comparing the 'as is' with the 'what we actually want'
----------------	--

Systems World

2.3	Stage 3	need to state what we want our new Manufacturing Strategy to do - before we name the relevant systems which will be defined to help us to achieve our objectives - use the business questionnaire results make a distinction between the 'systems world' and the real world situation
		need direct examples of relevant systems in Manufacturing we are focusing at each stage
2.3.1	Task 3.1	need a template for this bit - i.e. naming of relevant systems within manufacturing to help support business objectives and the new Manufacturing Strategy
2.4	Stage 4	developing the root definitions for each relevant system - the W should be implied by the facilitator - 'conditioned to our own "back garden view" - 'some back gardens may be bigger than others' give a structure on how a debate should be developed from the root definitions <i>all elements of the root definition must contribute to the Manufacturing Strategy</i> more examples of root definitions for each relevant systems identified change RD for Customer focused approach to Manufacturing Strategy formulation remove information on systems concepts and emergent properties - systems analyst will already know about these aspects and others wont really want to know
2.4.1.5	Template	helpful
2.5	Stage 5	development of conceptual models - mention hierarchies - numbering systems used and decomposition 5-7 activities or processes examples of IDEF0 alternative routes through the process
2.6	Stage 6	bringing real world and systems world together - need to think very carefully about the words used and who it is aimed at What does 'stakeholder' actually mean?? Need to recognise that its not all blue sky stuff - should be able to involve the shop floor as well.

Neil Kempford

CASE L ADDITIONAL COMMENTS

Development of the Workbook for a Soft Systems Approach to the formulation of a Manufacturing Strategy

Date	Wednesday 24th September 1997
Location	Case Company
Participants	- Chief Engineer - Head of Research and Development - Researcher
Time	08.00 - 10.00

Report

The workshop was organised to follow on from the previous meeting to discuss changes made and to arrange future contact with the organisation. Further comments addressing different aspects of the workbook included:

- a facilitators guide would be useful to enable the process to take place within the organisation without the researcher.
- the workshop participants stated that they would use the workbook to its full but were not sure when this would occur.
- The workbook is seen by the organisation as useful and would be used as part of a Manufacturing Strategy toolkit which complements work done by Cranfield on the CMASD project.
- It was felt that enough theorising had been done and that the grounding theory was solid. And that the team should get on with the process.
- The flow chart which was produced was felt to be inadequate and that a rich picture would be more appropriate to show the interactions, dependencies and a holistic view!
- It was recommended that the workbook included some advice on developing a data dictionary for the conceptual models inputs and outputs
- it was agreed that the background theory at the front of the workbook was relevant and at the right level.
- It was the general consensus of the workgroup participants that the workbooks applicability was wider than the aerospace industry.
- The end comment - 'it was useful to focus on the general business issues and manufacturing issues to develop the understanding of how the Manufacturing Strategy should evolve.

The workshop then moved to using the approach for the development of a Manufacturing Strategy. Due to time constraints it was unable to complete the first iteration of the workbook. This will be continued at a later date.

CR Bell
6.10.97

Section 2

Section 2 - The Soft Systems Approach to Manufacturing Strategy

Section 2 has been developed as a tool to be used when formulating a manufacturing strategy using soft systems thinking. It provides an objective for each stage, deliverables and tasks to be followed, together with tools and templates.

The Road Map [modified from Checkland & Scholes 1990]

The Problem Situation - Corporate and Business Strategy focusing on Manufacturing aspects

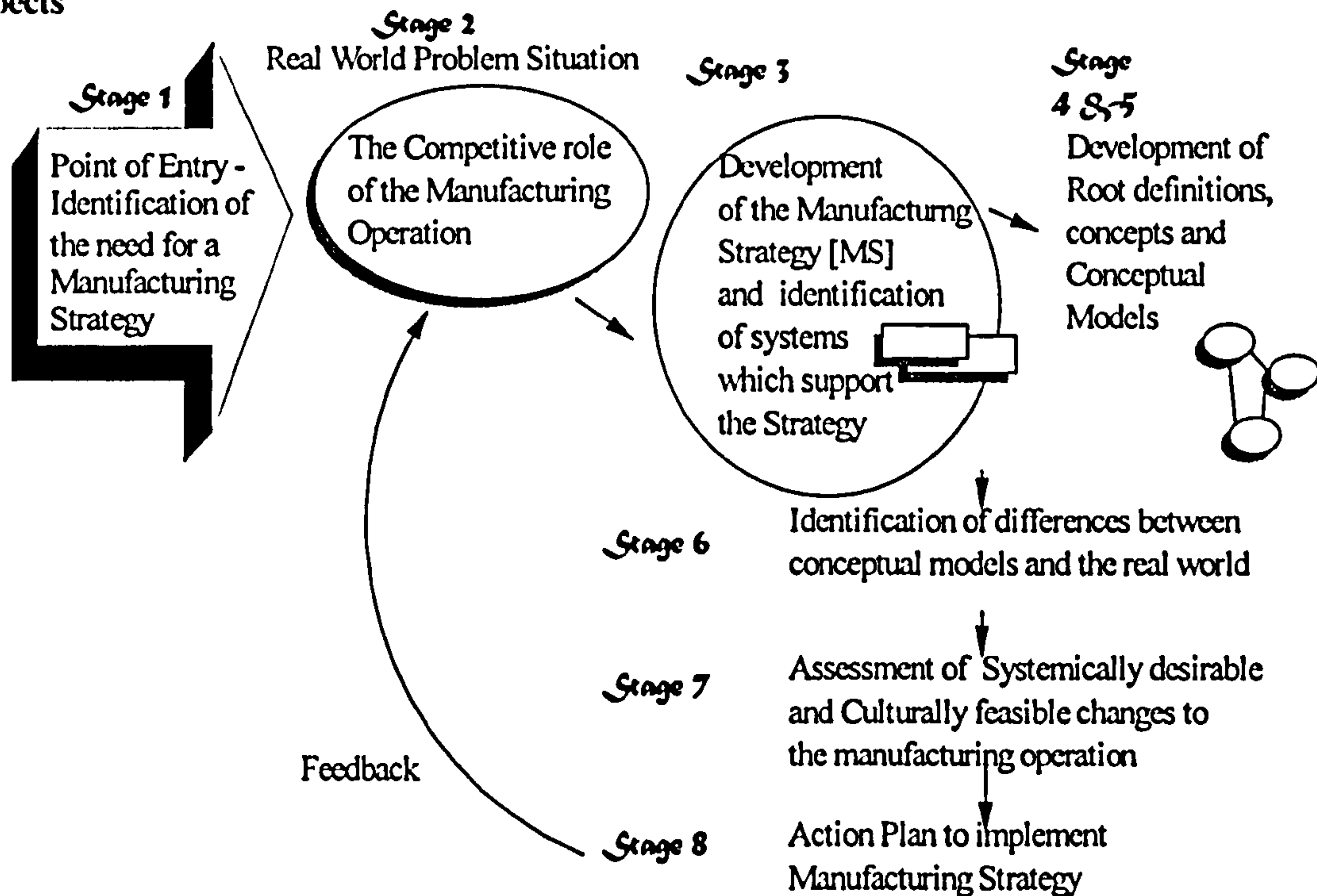

Stage 1

Does the Organisation see the need for change?

Is the organisation committed to developing a new or updated Manufacturing Strategy? This is a key stage in the Manufacturing Strategy formulation process and sets the tone for the development of the strategy. It is important to consider the place manufacturing has within your organisation, and the influence manufacturing can exert in supporting corporate objectives. Hayes and Wheelwright have developed a four stage model which is useful in determining your and other views of where manufacturing is seen in your organisation. This stage addresses the history of manufacturing's previous role within the organisation. This is important as it sets the scene for the development of the Manufacturing Strategy.

The Road Map - Stage 1



Objectives

- to identify the need for change and gain commitment from the relevant stakeholders

Deliverable

- Identification of Manufacturing Strategy Process Owner
- Identification of the current business strategy
- Agreement of current perceptions of Manufacturing within the organisation
- Identification of current Manufacturing Strategy [if any]
- Competitive profile
- Commitment at an appropriate level to include timescales and resources of the Manufacturing Strategy Formulation Process

Task 1.1 Identify Manufacturing Strategy formulation process owner and key manufacturing stakeholders within the organisation

Participants

The Manufacturing Strategy Formulation Team

- Manufacturing / Operations Director / Managers
- Marketing Director / Manager
- Purchasing Director / Manager
- Technology Manager
- Others?

Manufacturing & Purchasing Director

Chief Production Engineer

Sean - Resource Manager

Marketing Director

Technology Director

Manufacturing Team Leaders

Sources of Information

Organisation charts

Current Strategy Documents

Operations Plan

Current Policy Documents

+ value plan

notes to add - the issues of getting these people together at the same time is a difficult problem to overcome - guidelines should be developed as to how much resource will be required for the approach both in people, time and money - although the approach should be seen as a continuous process - the upfront resource may be needed to show the need for the approach to the top management team.

Task 1.2 Identify the current business strategy explicitly

Participants

The Manufacturing Strategy Formulation Process Owner and Team identified in task 1.1

Sources of Information

Current Strategy Documents, Operations Plan, Current Policy Documents

Tools and techniques - Business Strategy Questionnaire

The questionnaire is designed to get the Manufacturing Strategy Formulation team to explicitly state what the business strategy is and help to determine what is required of Manufacturing to enable the organisation to support the business strategy. The data from the questionnaire will be used at a later date to build up a picture of the organisation and Manufacturing's role within it.

Your organisation and its business:

How would you describe your organisations role within its industry?

Prime Contractor	Systems Integrator	Systems Supplier	Components Supplier
✓	✓	✓	✓
Engineer to Order	Make to Order	Assemble to order	Make to stock
✓	✓	✓	✓

Who are your major customers? Please tick as many as appropriate

Prime Contractors	Systems Integrators	Systems Suppliers	Components Suppliers
✓	✓	✓	<input type="checkbox"/>
Defence - General	Defence - Aerospace	Civil - Aerospace	Automotive Industry
✓	✓	✓	✓
Racing cars	Railways	Quasi Military	
✓	✓	✓	

Who are your main competitors?

Allied Signal, Pilkingtons, GEC, Smiths Industries, ERA

Which one of the following best describes your main strategic business objectives for your organisation

	Short Term	Medium Term	Long Term	Not at all
Cost leadership	<input type="checkbox"/>	<input type="checkbox"/>	<input type="checkbox"/>	<input type="checkbox"/>
Differentiation	<input type="checkbox"/>	<input type="checkbox"/>	<input type="checkbox"/>	<input type="checkbox"/>
Focus	✓	✓	✓	<input type="checkbox"/>
Survival	<input type="checkbox"/>	<input type="checkbox"/>	<input type="checkbox"/>	<input type="checkbox"/>
Sustain current position	<input type="checkbox"/>	<input type="checkbox"/>	<input type="checkbox"/>	<input type="checkbox"/>
Steady growth	✓	✓	<input type="checkbox"/>	<input type="checkbox"/>
Rapid growth	<input type="checkbox"/>	<input type="checkbox"/>	<input type="checkbox"/>	<input type="checkbox"/>
Develop new markets	✓	✓	✓	<input type="checkbox"/>
Become no 1 in particular field	✓	<input type="checkbox"/>	<input type="checkbox"/>	<input type="checkbox"/>
Become world class	<input type="checkbox"/>	<input type="checkbox"/>	✓	<input type="checkbox"/>
Technical Performance	✓	✓	<input type="checkbox"/>	<input type="checkbox"/>
Customer Support	✓	✓	<input type="checkbox"/>	<input type="checkbox"/>
Other	<input type="checkbox"/>	<input type="checkbox"/>	<input type="checkbox"/>	<input type="checkbox"/>

How do you mostly intend to achieve your objectives?

	Short term	Medium term	Long term		Short term	Medium term	Long term
Core competence focus	✓	✓	<input type="checkbox"/>	Innovation	✓	✓	✓
Core technologies focus	✓	✓	<input type="checkbox"/>	New products	✓	<input type="checkbox"/>	<input type="checkbox"/>
Research & Development	<input type="checkbox"/>	✓	✓	New Processes	✓	<input type="checkbox"/>	<input type="checkbox"/>
New Technology	<input type="checkbox"/>	<input type="checkbox"/>	<input type="checkbox"/>	Activity Based Costing	✓	<input type="checkbox"/>	<input type="checkbox"/>
Merger	<input type="checkbox"/>	<input type="checkbox"/>	<input type="checkbox"/>	Training	<input type="checkbox"/>	<input type="checkbox"/>	<input type="checkbox"/>
Collaboration	✓	✓	<input type="checkbox"/>	Acquisition	<input type="checkbox"/>	<input type="checkbox"/>	<input type="checkbox"/>
Restructuring	<input type="checkbox"/>	<input type="checkbox"/>	<input type="checkbox"/>	Flexibility	<input type="checkbox"/>	<input type="checkbox"/>	<input type="checkbox"/>
Increase efficiency	✓	✓	✓	Other	<input type="checkbox"/>	<input type="checkbox"/>	<input type="checkbox"/>

If other please add more detail

Changing attitude and empowerment

How would you describe the structure of your organisation? [You can tick more than 1]

Functional	Business Process Focused	Project Focused	Temporary
✓	<input type="checkbox"/>	✓	✓
Hierarchy	Matrix	Product focused	Other
<input type="checkbox"/>	✓	✓	<input type="checkbox"/>
Complicated	Flat		
<input type="checkbox"/>	✓		

How would you describe the culture of the organisation?

	Mostly	Moving towards	Not at all
Adversarial	<input type="checkbox"/>	<input type="checkbox"/>	✓
Innovative	✓	<input type="checkbox"/>	<input type="checkbox"/>
Traditional Taylorist	<input type="checkbox"/>	<input type="checkbox"/>	✓
Open and Honest	<input type="checkbox"/>	✓ towards	<input type="checkbox"/>
Blame culture	<input type="checkbox"/>	✓ away	<input type="checkbox"/>
Forward Thinking	<input type="checkbox"/>	✓ towards	<input type="checkbox"/>
Ticking over	<input type="checkbox"/>	<input type="checkbox"/>	✓
Other	<input type="checkbox"/>	<input type="checkbox"/>	<input type="checkbox"/>

Assimilation of data and Debate

The result of the questionnaire should provide the team with an explicit statement of the teams understanding of their business strategy. This should be expressed below:

The business strategy derived from the questionnaire states:

The business has a multi industry, multi product and multi customer strategy which focuses on steady growth and developing new markets. It is the organisations aim to become number 1 in a particular field by supporting our customers, focusing on core competences and technologies by continuing with R&D activities and collaboration. This is being supported by increasing internal efficiency and nurturing innovation to develop new products. This is underpinned by Activity Based Costing.

The current structure is functionally and matrix orientated focused on products and projects

The current culture is innovative and moving from a blame culture to one of openness and honesty.

Task 1.3 Identify the current perception of Manufacturing within the organisation.

Participants

The Manufacturing Strategy Formulation Process Owner and Team identified in task 1.1

Sources of Information

Own perceptions taking the culture of the organisation into account i.e. the artefacts, values and taken for granted.

Policies

Tools and techniques - Hayes and Wheelwright's 4 stage evolutionary Manufacturing model

Hayes and Wheelwright's 4 stage model has been used to describe the evolution of a Manufacturing organisation and can be useful to expose different stakeholder perceptions. Each key stakeholder should be asked to identify which stage they feel the manufacturing organisation has reached. No justification is required at this stage. The objective is to identify if there is a need for a Manufacturing Strategy or a need for an updated Manufacturing Strategy.

<i>Stage</i>	<i>Description</i>	<i>Explanation</i>
1.	Internally neutral	The objective is to minimise the negative impact of the manufacturing function. The manufacturing function is described as inward looking and tends to be reactive with a great deal of effort expended on 'fire fighting'.
2.	Externally neutral	The objective is to obtain parity with competitors usually following industry best practice. Stage 2 is achieved when the manufacturing organisation starts to look outwards and see what similar entities are doing and to identify appropriate best practice.
3.	Internally supportive:	Manufacturing exists to support business strategy. The manufacturing organisation is world class and up with the best. Manufacturing is consulted when changes are made in business strategy
4.	Externally supportive	Manufacturing capabilities shape business strategy in terms of the types of products developed and the ways in which markets are addressed. Manufacturing is seen as the basis for the long term health and success of the organisation. Manufacturing is seen as being proactive and innovative in its approach.

To help determine the perceptions of manufacturing within the organisation a matrix has been formulated as a guide. Use a highlighter to determine where your organisation currently sits.

	People	Processes	Technology
<p>Stage 1 Internally Neutral</p> <p>Minimise the negative effects of manufacturing Aiming for Repeatability</p> <p><i>'Stop making mistakes'</i></p>	<ul style="list-style-type: none"> • Specialisation • Point of entry not reached • coordination • Taylorism • functional accountability 	<ul style="list-style-type: none"> • Functional Organisation • Quality improvement programmes • Delivery focus 'get it out the door' 	<ul style="list-style-type: none"> • Materials Resource Planning MRP • Manufacturing Resource Planning MPR2 • Scheduling • Variance reporting • Group technology
<p>Stage 2 Externally Neutral</p> <p>maintain parity keep up with the competition Aiming for Stability</p> <p><i>'be among the best'</i></p>	<ul style="list-style-type: none"> • Quality circles • Teaming • Mixing the disciplines 	<ul style="list-style-type: none"> • SPC, JIT, • DFM, CAPM, TQM, World Class Manufacturing, BPR • Benchmarking • Best Practice • Quality improvement • Activity Based Costing • focus on quality 	<ul style="list-style-type: none"> • Manufacturing Resource Planning • Process control • Cells
<p>Stage 3 Internally Supportive</p> <p>Manufacturing supports the business strategy Aiming for Flexibility</p> <p><i>'be clearly the best'</i></p>	<ul style="list-style-type: none"> • Concurrent engineering • Team based 	<ul style="list-style-type: none"> • Business Process Focus, • Supply chain management • focus on cost • throughput accounting 	<ul style="list-style-type: none"> • Enterprise Resource Planning • Information Technology underpins processes • strategic investment in automation
<p>Stage 4 Externally Supportive</p> <p>Manufacturing capabilities shape business strategy Aiming for Versatility</p> <p><i>'sustain superiority through an operations advantage'</i></p>	<ul style="list-style-type: none"> • Development of core competence - skills and knowledge which are difficult to replicate • Integrated product teams • knowledge based organisation • 'surgeon' structure' 	<ul style="list-style-type: none"> • The learning organisation • Blurring of functions • Business process focused organisation • Market creation using manufacturing competencies • focus on product variability 	<ul style="list-style-type: none"> • Systems Integration • Product Information Environment • Computer Integrated Manufacturing

developed from Hayes and Wheelwright's 4 stage model and Laurie Rumens model.

1.1. Case M

The validation carried out with Case M was gathered from workshops and meetings between July 1997 and April 1998

1.1.1. Participants

Manufacturing engineering manager
Senior Logistics engineer
The researcher

The data was validated by the participants who read the reports for each meeting provided feedback and signatures.

1.2. Validation approach

The participants were led through the grounding theory to the approach and the approach stages by the author. The purpose for this was to ensure the participants had a grounding in systems thinking and understood the issues and semantics prior to working through the approach.

The results of the approach are included in the supporting documentation. The general comments on the day included:

- 'good tool to understand the process of manufacturing strategy'
- 'stimulates discussion'
- 'provides a thread to lead the team from the business issues through to the manufacturing strategy'
- 'an inclusion of a time frame would be beneficial'
- 'a shared understanding can be developed'
- 'conflict and political issues will be the key to manage within the process.'

At the end of the workshop, it was agreed to hold an away weekend to bring together the key stakeholders to run through one cycle. Unfortunately this was put on hold. A letter was received asking to reschedule.

Final comment 'we are convinced that this approach has merit'

CASE M - ADDITIONAL COMMENTS

BRITISH AEROSPACE 
Military Aircraft & Aerostructures

British Aerospace
Military Aircraft & Aerostructures
Samlesbury Aerodrome
Balderstone, Blackburn, Lancashire
BB2 7LF United Kingdom

Telephone +44 (0)1254 812371
Facsimile +44 (0)1254 768100
Telex 63435

Direct Telephone +44 (0)1254 768925

Direct Facsimile +44 (0)1254 766562

Business Support,
Military Airframes,
S46B

28th August 1997

T.J.Greswell,
School of Computing
University of Plymouth,
Drake Circus,
Plymouth,
Devon,
PL4 8AA

Dear Tammi,

I am writing to thank you for your considerable efforts in the formulation of your Workbook for the Soft Systems Approach to the formulation of a Manufacturing Strategy. The validation workshop attended by myself and Mike Crompton on 9th July was a valuable and interesting learning experience for both of us, and we are convinced that this approach has considerable merit.

We would also like to thank you for your response to the proposal to widen the audience and participation within the Warton Unit and the Eurofighter Project by arranging an "awayday" to further develop the Eurofighter Manufacturing Strategy using the Soft Systems Approach.

However, due to the current restructuring of the senior management team, the possibility of bringing together the participants for the proposed awayday seems to be small at this moment in time. I would therefore appreciate it if we could reschedule the proposal for October when we should be able to give it the attention it deserves.

I would also like to take this opportunity to wish you success with your project and all the best in your future career, and I hope to see you back at Samlesbury some time in the near future.

Best regards



Charlie Bamber
Snr Logistics Engineer

cc. M.Crompton

Validation workshop 3 - CASE M

Participants: Mike, Charlie, Tammi

Location: New Filton House Conference Room B, Bristol

Date: July 9th 1997: 9.30 - 3.15

Agenda for workshop

Introduction

Evolution of workbook

PhD and key areas of research

Organisational development, Manufacturing Strategy, Systems Theory, Soft

Systems Thinking

The workbook

Section 1 - background theory

Section 2 - the soft systems approach to the formulation of a Manufacturing

Strategy

Section 3 - glossary of terms

Section 4 - validation by case companies

Comments

'good tool to understand the process of Manufacturing Strategy'

'stimulates discussion'

'provides a thread to lead the team from the business issues through to Manufacturing strategy'

'an inclusion of the time frame would be beneficial'

'it is important that we don't know where we are going at the beginning - i.e. we have no assumptions as to where the process will lead - this stimulates discussion'

'a shared understanding can be developed'

'conflict and political issues will be the key issues to manage within the process'

suggested organizing an away weekend with the IPT leaders, manufacturing managers, site director, EF operations director and the customer support director - a proposal will follow this report

Flip chart summary

MAD_SSM.DOC

11/07/97

Page 1

Validation workshop 3

Slide 1 - Objectives of meeting

- For Company A
- understand if we can use the Soft Systems Approach to Manufacturing Strategy
 - applicability for the project
 - understand the soft systems approach
 - learn the advantages of the soft systems approach

- For the research
- further validation and development of the workbook
 - determine next step in the validation process with Company A

Slide 2 - Strategy Hierarchies

Hierarchies of Strategy

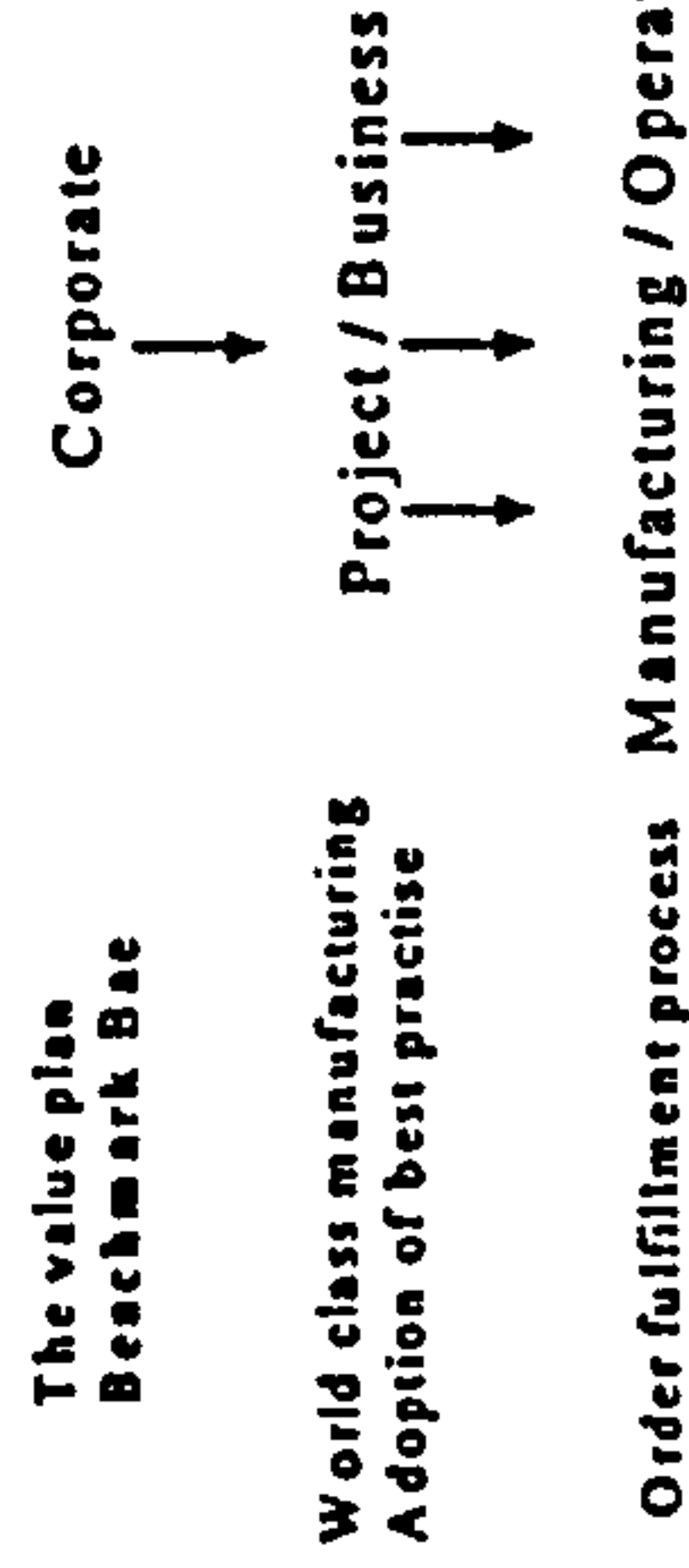

Slide 3 - example of IDEFO - already covered in workbook

Slide 4 - scope - setting the boundary

Warton Unit & Eurofighter -

Detailed businesses - manufacturing organization - composites, machining, fabrication, electric's
Ross Bradley

MAD_SSM.DOC

11/07/97

Page 2

CASE M

Final Assembly [structures] - 4 shed
Final Assembly - Warton

Samlesbury - competence based.

Slide 5 - The Team

Pete Blundell - Manufacturing Operations Manager
Integration Team - IPTs
Ross Bradley
Trevor King - Customer Support Directorate

Slide 6 - The learning organization

Tacit knowledge
Implicit knowledge
embedded knowledge

learning centres support individual learning

Slide 7 - Process Architecture

Get order
Order fulfillment - supported by Baan
Get material
Make
Deliver
Support Customer

Slide 8 - Root Definition of the Manufacturing Control System

A system to deliver a product at competitive cost, with high schedule adherence and quality with minimum inventory by means of controlling the flow of materials, information and product in order to delight the customer.

Slide 9 - development of conceptual model from root definition developed for the Manufacturing Control System

Development of conceptual model using IDEFo notation

INPUTS

- Parts list [BoM]
- Lead Time information
- Suppliers Information
- Ordering information
- Task Directive
- Materials
- Order

OUTPUTS

- Product
- Planned omissions
- Certification [CoC]
- Waste / Scrap

Development of conceptual model using IDEFo notation

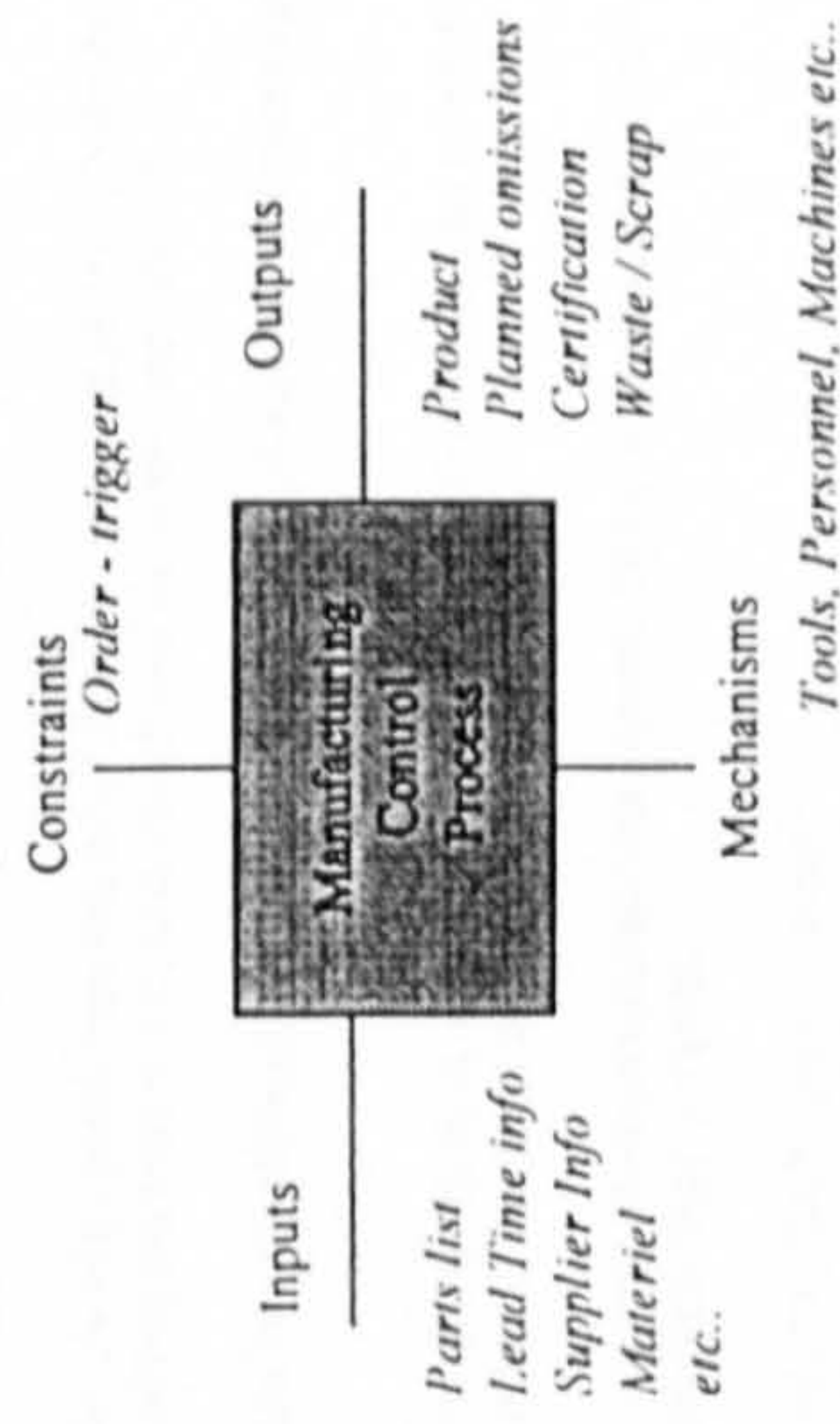

Validation Workshop

for

Work book for the Soft Systems Approach to the formulation of a Manufacturing Strategy

Case Company A

The following report captures the responses from case company A from a validation workshop held on the 9th July 1997. The comments will be summarised at the end of the report.

T J Greswell
School of Computing
University of Plymouth
Drake Circus, Plymouth
Devon, PL4 8AA, UK

TGRESWELL@plym.ac.uk
Tel 01752 - 232620
Fax 01752 - 232540

Page 1
11/07/97 14:18
Version: draft

TABLE OF CONTENTS

1. SECTION 2 - THE SOFT SYSTEMS APPROACH TO MANUFACTURING STRATEGY	3
1.1 DOES THE ORGANISATION SEE THE NEED FOR CHANGE?	5
1.1.1 TASK 1.1 IDENTIFY MANUFACTURING STRATEGY FORMULATION PROCESS OWNER AND KEY MANUFACTURING STAKEHOLDERS WITHIN THE ORGANISATION. IDENTIFY THE SCOPE OF THE PROCESS	6
1.1.2 TASK 1.2 IDENTIFY THE CURRENT BUSINESS STRATEGY EXPLICITLY	6
1.1.3 TASK 1.3 IDENTIFY THE CURRENT PERCEPTION OF MANUFACTURING WITHIN THE ORGANISATION.	10
1.1.4 TASK 1.3 IDENTIFY AND EXPLICITLY STATE THE CURRENT MANUFACTURING STRATEGY	12
1.1.5 TASK 1.5 GAIN COMMITMENT FOR THE NEXT STAGE OF THE MANUFACTURING STRATEGY FORMULATION PROCESS.	13
1.2 FORMULATION OF A MANUFACTURING STRATEGY [THE REAL WORLD PROBLEM SITUATION - UNSTRUCTURED]	14
1.2.1 TASK 2.1 QUESTIONNAIRE FOR THE DEVELOPMENT OF UNDERSTANDING OF THE MANUFACTURING ORGANISATION	15
1.2.2 TASK 2.2 DEVELOPMENT OF RICH PICTURE	20
1.3 THE PROBLEM SITUATION - THE DEVELOPMENT OF THE MANUFACTURING STRATEGY? <i>WHAT DO WE WANT MANUFACTURING TO ACHIEVE [HOW AND WHAT?]</i>	22
1.3.1 TASK 3.1 DEVELOP A STATEMENT OF WHAT THE ORGANISATION EXPECTS OF MANUFACTURING. IDENTIFY SPECIFIC STRATEGIC OBJECTIVES FOR MANUFACTURING.	23
1.3.2 TASK 3.1 IDENTIFY SYSTEMS WHICH HAVE A SIGNIFICANT ROLE IN ACHIEVING OR SUPPORTING THE MANUFACTURING STRATEGY. N.B. KEY ENABLERS	23
1.4 THE DEVELOPMENT OF THE ROOT DEFINITIONS FOR EACH RELEVANT SYSTEM SELECTED IN STAGE 3	25
1.4.1 TASK 4.1 DEVELOP ROOT DEFINITION FOR WHAT YOU WANT YOUR RELEVANT SYSTEMS TO ACHIEVE IN TERMS OF SUPPORTING THE MANUFACTURING OBJECTIVES IDENTIFIED PREVIOUSLY.	25
1.5 THE DEVELOPMENT OF CONCEPTUAL MODELS DERIVED FROM THE ROOT DEFINITIONS FROM EACH RELEVANT SYSTEM	29
1.5.1 TASK 5.1 DEVELOP CONCEPTUAL MODELS OF THE CHOSEN RELEVANT SYSTEMS USING THE ROOT DEFINITIONS AND SYSTEMS CONCEPTS DEVELOPED IN STAGE 4	29
1.6 THE COMPARISON OF THE CONCEPTUAL MODELS AGAINST THE REAL WORLD SITUATION AND THE 3 MANUFACTURING STRATEGY ARCHETYPES.	34
1.6.1 TASK 6.1 COMPLETE COMPARISON TABLE/S	34
1.6.2 CONCEPTUAL MODELS OF THE 3 MANUFACTURING STRATEGY ARCHETYPES	36

Page 2
11/07/97 14:18
Version: draft

Section 2

1. Section 2 - The Soft Systems Approach to Manufacturing Strategy

Section 2 has been developed as a tool to be used when formulating a manufacturing strategy using soft systems thinking. It provides the process with an objective of each stage, deliverables and tasks to be followed.

The Road Map promoted from Churchland & Sobieski 1990

The Problem Situation - Corporate and Business Strategy focusing on Manufacturing aspects

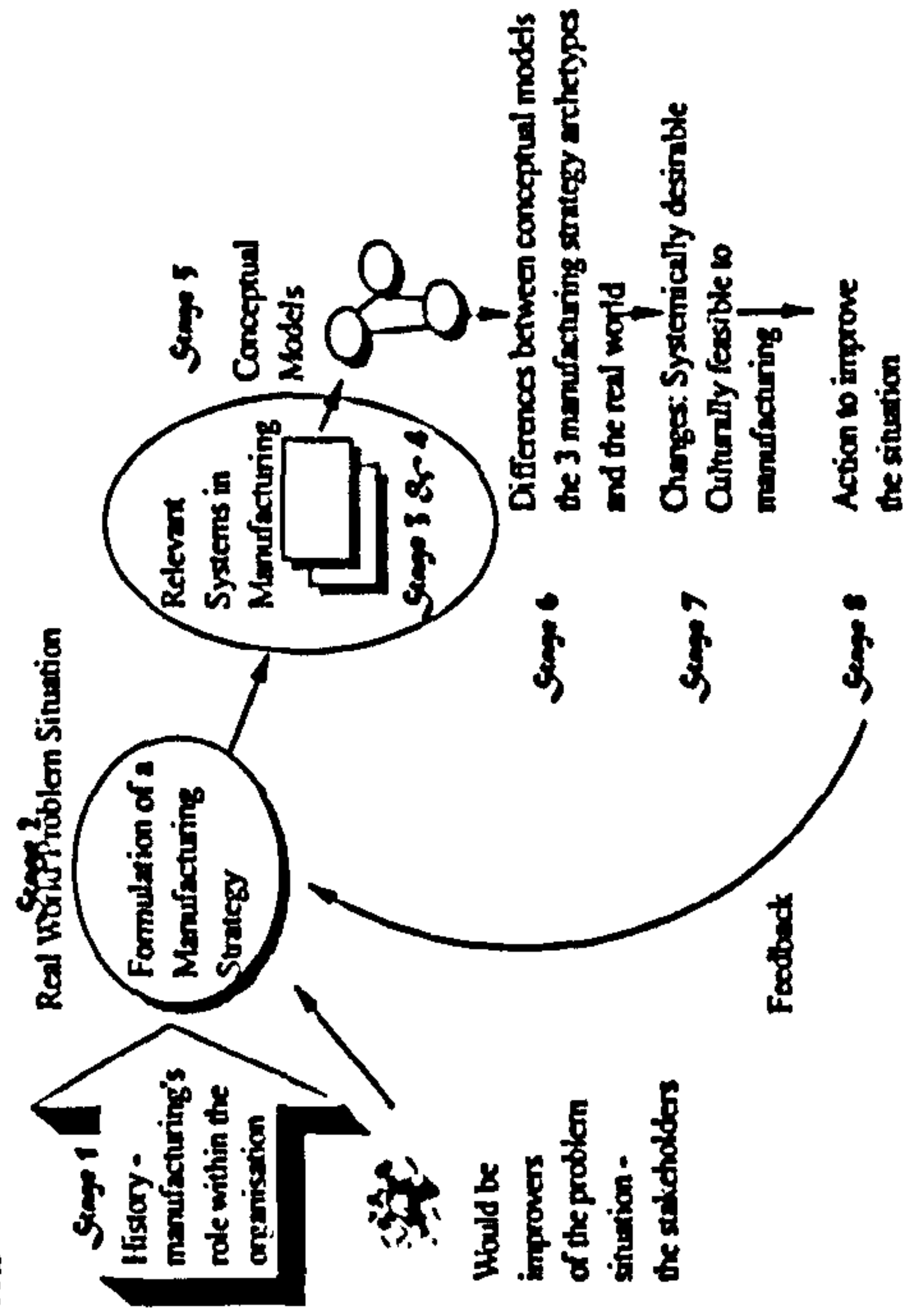

Table of contents

1. SECTION 2 - THE SOFT SYSTEMS APPROACH TO MANUFACTURING STRATEGY	3
1.1 DOES THE ORGANISATION SEE THE NEED FOR CHANGE?	5
1.1.1 TASK 1.1 IDENTIFY MANUFACTURING STRATEGY FORMULATION PROCESS OWNER AND KEY MANUFACTURING STAKEHOLDERS WITHIN THE ORGANISATION. IDENTIFY THE SCOPE OF THE PROCESS	6
1.1.2 TASK 1.2 IDENTIFY THE CURRENT BUSINESS STRATEGY EXPLICITLY	6
1.1.3 TASK 1.3 IDENTIFY THE CURRENT PERCEPTION OF MANUFACTURING WITHIN THE ORGANISATION.	10
1.1.4 TASK 1.4 IDENTIFY AND EXPLICITLY STATE THE CURRENT MANUFACTURING STRATEGY	12
1.1.5 TASK 1.5 GAIN COMMITMENT FOR THE NEXT STAGE OF THE MANUFACTURING STRATEGY FORMULATION PROCESS.	13
1.2 FORMULATION OF A MANUFACTURING STRATEGY [THE REAL WORLD PROBLEM SITUATION - UNSTRUCTURED]	14
1.2.1 TASK 2.1 QUESTIONNAIRE FOR THE DEVELOPMENT OF UNDERSTANDING OF THE MANUFACTURING ORGANISATION	15
1.2.2 TASK 2.2 DEVELOPMENT OF RICH PICTURE	20
1.3 THE PROBLEM SITUATION - THE DEVELOPMENT OF THE MANUFACTURING STRATEGY? <i>WHAT DO WE WANT MANUFACTURING TO ACHIEVE [HOW AND WHAT?]</i>	22
1.3.1 TASK 3.1 DEVELOP A STATEMENT OF WHAT THE ORGANISATION EXPECTS OF MANUFACTURING. IDENTIFY SPECIFIC STRATEGIC OBJECTIVES FOR MANUFACTURING.	23
1.3.2 TASK 3.1 IDENTIFY SYSTEMS WHICH HAVE A SIGNIFICANT ROLE IN ACHIEVING OR SUPPORTING THE MANUFACTURING STRATEGY. N.B. KEY ENABLERS	23
1.4 THE DEVELOPMENT OF THE ROOT DEFINITIONS FOR EACH RELEVANT SYSTEM SELECTED IN STAGE 3	25
1.4.1 TASK 4.1 DEVELOP ROOT DEFINITION FOR WHAT YOU WANT YOUR RELEVANT SYSTEMS TO ACHIEVE IN TERMS OF SUPPORTING THE MANUFACTURING OBJECTIVES IDENTIFIED PREVIOUSLY.	25
1.5 THE DEVELOPMENT OF CONCEPTUAL MODELS DERIVED FROM THE ROOT DEFINITIONS FROM EACH RELEVANT SYSTEM	29
1.5.1 TASK 5.1 DEVELOP CONCEPTUAL MODELS OF THE CHOSEN RELEVANT SYSTEMS USING THE ROOT DEFINITIONS AND SYSTEMS CONCEPTS DEVELOPED IN STAGE 4	29
1.6 THE COMPARISON OF THE CONCEPTUAL MODELS AGAINST THE REAL WORLD SITUATION AND THE 3 MANUFACTURING STRATEGY ARCHETYPES.	34
1.6.1 TASK 6.1 COMPLETE COMPARISON TABLE/S	34
1.6.2 CONCEPTUAL MODELS OF THE 3 MANUFACTURING STRATEGY ARCHETYPES	36

Stage 1

1.1 Does the Organisation see the need for change?

Is the organisation committed to developing a new or updated Manufacturing Strategy? This is a key stage in the Manufacturing Strategy formulation process and sets the tone for the development of the strategy. It is important to consider the place manufacturing has within your organisation, and the influence manufacturing can exert in supporting corporate objectives. Hayes and Wheelwright have developed a four stage model which is useful in determining your and other views of where manufacturing is seen in your organisation. This stage addresses the history of manufacturing's previous role within the organisation. This is important as it sets the scene for the development of the Manufacturing Strategy.

The Road Map - Stage 1

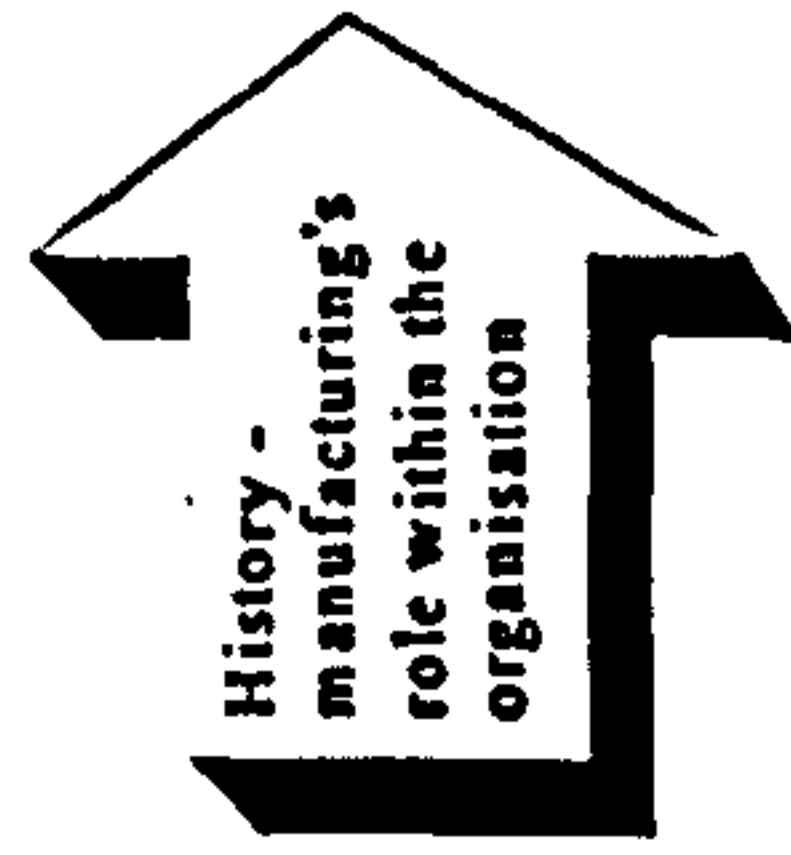

Objectives

- to identify the need for change and gain commitment from the relevant stakeholders

Deliverable

- Identification of Manufacturing Strategy Process Owner
- Identification of the current business strategy
- Agreement of current perceptions of Manufacturing within the organisation
- Identification of current Manufacturing Strategy [if any]
- Competitive profile
- Commitment at an appropriate level to include timescales and resources of the Manufacturing Strategy Formulation Process

1.1.1 Task 1.1 Identify Manufacturing Strategy formulation process owner and key manufacturing stakeholders within the organisation. Identify the scope of the process

1.1.1.1 Participants

The Manufacturing Strategy Formulation Team

- Manufacturing / Operations Director / Managers
- Marketing Director / Manager
- Purchasing Director / Manager
- Technology Manager
- Others?

1.1.1.2 Sources of Information

Organisation charts
Current Strategy Documents
Operations Plan
Current Policy Documents

The team was identified as:

- Manufacturing Operations manager - Pete Barrow
- The Integration Team - IPT leaders
- EF Operations Director - Ross Bradley
- CSD - Trevor King
- Manufacturing Managers

The scope was identified as covering Warton Unit

Comments

need to think about the personalities involved, moving from one stage of the project to another i.e. Design to PJ 'round pegs in square holes'

1.1.2 Task 1.2 Identify the current business strategy explicitly

1.1.2.1 Participants

The Manufacturing Strategy Formulation Process Owner and Team identified in task 1.1

1.1.2.2 Sources of Information

Current Strategy Documents, Operations Plan, Current Policy Documents

1.1.2.3 Tools and techniques - Business Strategy Questionnaire

The questionnaire is designed to get the Manufacturing Strategy Formulation team to explicitly state what the business strategy is and help to determine what is required of Manufacturing to enable the organisation to support the business strategy. The data from the questionnaire will be used at a later date to build up a rich picture of the organisation and Manufacturing's role within it.

Your organisation and its business:

How would you describe your organisations role within the aerospace industry?

Prime Contractor Systems Integrator Systems Supplier Components Supplier

Who are your major customers? Please tick as many as appropriate

Prime Contractors Systems Integrators Systems Suppliers Components Suppliers
 Defence - General Defence - Aerospace Civil - Aerospace Automotive Industry

Job Shop

Who are your main competitors?

Other parts of MAD. E.g. Brough, Boeing, McDonnell Douglas, Airbus, European Partners, Dassault,
 Saab, Russians

Which one of the following best describes your main strategic business objectives for your organisation

	1 - 2 years Short Term	5 years Medium Term	10 + years Long Term	Not at all
Cost leadership	<input checked="" type="checkbox"/>	<input type="checkbox"/>	<input type="checkbox"/>	<input type="checkbox"/>
Differentiation of markets	<input type="checkbox"/>	<input checked="" type="checkbox"/>	<input type="checkbox"/>	<input type="checkbox"/>
Focus	<input type="checkbox"/>	<input type="checkbox"/>	<input checked="" type="checkbox"/>	<input type="checkbox"/>
Survival	<input checked="" type="checkbox"/>	<input type="checkbox"/>	<input type="checkbox"/>	<input type="checkbox"/>
Sustain current position	<input checked="" type="checkbox"/>	<input type="checkbox"/>	<input type="checkbox"/>	<input type="checkbox"/>
Steady growth	<input type="checkbox"/>	<input checked="" type="checkbox"/>	<input type="checkbox"/>	<input type="checkbox"/>
Rapid growth	<input type="checkbox"/>	<input type="checkbox"/>	<input type="checkbox"/>	<input checked="" type="checkbox"/>
Develop new markets	<input type="checkbox"/>	<input checked="" type="checkbox"/>	<input type="checkbox"/>	<input type="checkbox"/>
Become no 1 in particular field {benchmark}	<input type="checkbox"/>	<input type="checkbox"/>	<input checked="" type="checkbox"/>	<input type="checkbox"/>
Become world class	<input type="checkbox"/>	<input type="checkbox"/>	<input checked="" type="checkbox"/>	<input type="checkbox"/>
Other	<input type="checkbox"/>	<input type="checkbox"/>	<input type="checkbox"/>	<input type="checkbox"/>

If other, please briefly specify.

Become number 1 in Europe

How do you mostly intend to achieve your objectives?

	1 - 2 Short Term	5 Medium Term	10 + Long Term	Short term	Medium term	Long term
Core competence focus	<input checked="" type="checkbox"/>	<input type="checkbox"/>	<input type="checkbox"/>	<input checked="" type="checkbox"/>	<input type="checkbox"/>	<input checked="" type="checkbox"/>
Core technologies focus	<input checked="" type="checkbox"/>	<input type="checkbox"/>	<input type="checkbox"/>	<input type="checkbox"/>	<input type="checkbox"/>	<input type="checkbox"/>
R & D	<input type="checkbox"/>	<input type="checkbox"/>	<input type="checkbox"/>	<input checked="" type="checkbox"/>	<input type="checkbox"/>	<input type="checkbox"/>
New Technology	<input checked="" type="checkbox"/>	<input type="checkbox"/>	<input checked="" type="checkbox"/>	<input type="checkbox"/>	<input type="checkbox"/>	<input type="checkbox"/>
Merger	<input type="checkbox"/>	<input type="checkbox"/>	<input type="checkbox"/>	<input checked="" type="checkbox"/>	<input type="checkbox"/>	<input type="checkbox"/>
Collaboration	<input checked="" type="checkbox"/>	<input type="checkbox"/>	<input type="checkbox"/>	<input type="checkbox"/>	<input type="checkbox"/>	<input type="checkbox"/>
Restructuring	<input checked="" type="checkbox"/>	<input type="checkbox"/>	<input type="checkbox"/>	<input type="checkbox"/>	<input checked="" type="checkbox"/>	<input type="checkbox"/>
Increase efficiency [OEI]	<input type="checkbox"/>	<input checked="" type="checkbox"/>	<input type="checkbox"/>	<input type="checkbox"/>	<input type="checkbox"/>	<input type="checkbox"/>

If other please add more detail

note - problem with legacy systems

How would you describe the structure of your organisation? [You can tick more than 1]

Functional <input checked="" type="checkbox"/>	Business Process Focused <input type="checkbox"/>	Project Focused <input checked="" type="checkbox"/>	Temporary <input type="checkbox"/>
Hierarchy <input checked="" type="checkbox"/>	Matrix <input checked="" type="checkbox"/>	Product focused <input checked="" type="checkbox"/>	Other <input type="checkbox"/>
Complicated <input checked="" type="checkbox"/>	Flat <input type="checkbox"/>		

How would you describe the culture of the organisation?

Adversarial <input checked="" type="checkbox"/>	Innovative <input checked="" type="checkbox"/>	Traditional Taylorist <input type="checkbox"/>	Open and Honest <input type="checkbox"/>
Blame culture <input checked="" type="checkbox"/>	Forward Thinking <input type="checkbox"/>	Ticking over <input type="checkbox"/>	Other <input type="checkbox"/>
Task orientated <input checked="" type="checkbox"/>	Buzz word culture / bandwagonism <input checked="" type="checkbox"/>	Arrogant <input checked="" type="checkbox"/>	'do a bit of everything' <input checked="" type="checkbox"/>

1.1.2.4 Assimilation of data and Debate

The result of the questionnaire should provide the team with an explicit statement of the teams understanding of their business strategy. This should be expressed below:

The business strategy states: [for Warton Unit]

ADOPTION OF BEST PRACTICE - FOLLOWING FASHION

1.1.3 Task 1.3 Identify the current perception of Manufacturing within the organisation.

1.1.3.1 Participants

The Manufacturing Strategy Formulation Process Owner and Team identified in task 1.1

1.1.3.2 Sources of Information

Own perceptions taking the culture of the organisation into account i.e. the artefacts, values and taken for granted.
Policies

1.1.3.3 Tools and techniques - Hayes and Wheelwright's 4 stage evolutionary Manufacturing model

Hayes and Wheelwright's 4 stage model has been used to describe the evolution of a Manufacturing organisation and can be useful to expose different stakeholder perceptions. Each key stakeholder should be asked to identify which stage they feel the manufacturing organisation has reached. No justification is required at this stage. The objective is to identify if there is a need for a Manufacturing Strategy or a need for an updated Manufacturing Strategy.

Stage	Description	Explanation
-------	-------------	-------------

- 1. Internally neutral**
The objective is to minimise the negative impact of the manufacturing function. The manufacturing function is described as inward looking and tends to be reactive with a great deal of effort expended on 'fire fighting'.
- 2. Externally neutral**
The objective is to obtain parity with competitors usually following industry best practice. Stage 2 is achieved when the manufacturing organisation starts to look outwards and see what similar entities are doing and to identify appropriate best practice.
- 3. Internally supportive:**
Manufacturing exists to support business strategy. The manufacturing organisation is world class and up with the best. Manufacturing is consulted when changes are made in business strategy
- 4. Externally supportive**
Manufacturing capabilities shape business strategy in terms of the types of products developed and the ways in which markets are addressed. Manufacturing is seen as the basis for the long term health and success of the organisation. Manufacturing is seen as being proactive and innovative in its approach.

To help determine the perceptions of manufacturing within the organisation a matrix has been formulated as a guide. Use a highlighter to determine where you organisation currently sits.

	People	Processes	Technology
Stage 1 Internally Neutral Minimise the negative effects of manufacturing Aiming for Repeatability 'Stop making mistakes'	<ul style="list-style-type: none"> Specialisation Point of entry not reached coordination Taylorism functional accountability 	<ul style="list-style-type: none"> Functional Organisation Quality improvement programmes Delivery focus 'get it out the door' 	<ul style="list-style-type: none"> Materials Resource Planning MRP Manufacturing Resource Planning MPR2 Scheduling Variance reporting Group technology
Stage 2 Externally Neutral maintain parity keep up with the competition Aiming for Stability 'be among the best'	<ul style="list-style-type: none"> Quality circles Teaming Mixing the disciplines 	<ul style="list-style-type: none"> SPC, JIT, DFM, CAPM, TQM, World Class Manufacturing, BPR Benchmarking Best Practice Just-In-Time Quality improvement Activity Based Costing focus on quality 	<ul style="list-style-type: none"> Manufacturing Resource Planning Process control Cells
Stage 3 Internally Supportive Manufacturing supports the business strategy Aiming for Flexibility 'be clearly the best'	<ul style="list-style-type: none"> Concurrent engineering Team based 	<ul style="list-style-type: none"> Business Process Focus, Supply chain management focus on cost throughput accounting 	<ul style="list-style-type: none"> Enterprise Resource Planning Information Technology underpins processes strategic investment in automation
Stage 4 Externally Supportive Manufacturing capabilities shape business strategy Aiming for Versatility 'sustain superiority through an operations advantage'	<ul style="list-style-type: none"> Development of core competence - skills and knowledge which are difficult to replicate Integrated product teams knowledge based organisation 'surgeon' structure' 	<ul style="list-style-type: none"> The learning organisation Blurring of functions Business process focused organisation Market creation using manufacturing competencies focus on product variability 	<ul style="list-style-type: none"> Systems Integration Product Information Environment Computer Integrated Manufacturing

Developed from Hayes and Wheelwright's 4 stage model and Lumsden Rummen model.

1.1.3.4 Assimilation of data and Debate

The matrix should be used to focus attention on what Manufacturing should be aiming for in order to support business objectives. A statement should be made identifying where the organisation currently appears to be and secondly where the organisation wants manufacturing to be.

The manufacturing organisation appears to be at stage STAGE 1 AND 2
The organisation wants manufacturing to be at stage STAGE 3

1.1.4 Task 1.3 Identify and explicitly state the current Manufacturing Strategy

1.1.4.1 Participants

The Manufacturing Strategy Formulation Process Owner and Team identified in task 1.1

1.1.4.2 Sources of Information

Organisational documents, family trees, personal knowledge, change management programmes, manufacturing operations policy documents

1.1.4.3 Assimilation of data and Debate

Explicitly state the current Manufacturing Strategy. If there is no Manufacturing Strategy written down describe the current emergent strategy if possible.

The current Manufacturing Strategy states: World Class Manufacturing & Best Practice 5 tier model - asking what market are we in - what products are we making Tier 1 - final a/c Tier 2 - major units Tier 3 - Minor Units Tier 4 - Sub assembly Tier 5 - Components
--

Is the current Manufacturing Strategy adequate in meeting the strategic business objectives?

	Short term	Medium term	Long term
YES	<input type="checkbox"/>	<input checked="" type="checkbox"/>	<input type="checkbox"/>
NO	<input checked="" type="checkbox"/>	<input type="checkbox"/>	<input type="checkbox"/>
DON'T KNOW	<input type="checkbox"/>	<input type="checkbox"/>	<input type="checkbox"/>

1.1.5 Task 1.5 Gain commitment for the next stage of the Manufacturing Strategy Formulation process.

If all key stakeholders now appreciate the need / requirement for a Manufacturing Strategy task 1.5 should be completed to ensure all stakeholders are aware of the timescales and commitment available to them.

An explicit statement is required at this stage that it is recognised that a problem exists and that there is a need to process with the workbook.

1.1.5.1 What we have achieved by this stage

- an explicit statement of the Manufacturing Strategy Formulation process owner and team members
- an explicit statement of the business strategy
- an explicit statement of the current perception of Manufacturing using Hayes and Wheelwrights 4 stage model
- an explicit statement of the current Manufacturing Strategy [if one exists]
- a statement of commitment for the continuation of the process
- an explicit statement of the identification that a problem exists
- the identification of the need for the process to continue

Stage 2

1.2 Formulation of a Manufacturing Strategy [The real world problem situation - unstructured]

The Road Map - Stage 2

Objectives

- to develop an understanding of the current situation of the manufacturing operation and its influences, including the environment, key issues concerning customers, products, suppliers, competitors, problems

Deliverable

- Completion of rich picture questionnaire
- Drawing of a rich picture to depict the current situation of the manufacturing operation depicting key issues and interactions to develop a greater understanding

Real World Problem Situation

Formulation of a Manufacturing Strategy to support business objectives

1.2.1 Task 2.1 Questionnaire for the development of understanding of the manufacturing organisation

The questionnaire will be divided into several sections. Each section will ask you to think about certain aspects of your business, your corporate strategy, your planning processes, your customers, your products, and your current manufacturing strategy. The questionnaire will then enable the drawing of a rich picture to show the current situation as you see it. Each key stakeholder should be asked to complete the questionnaire, it must be stressed that at this stage it is the AS IS of the manufacturing system [function of order fulfilment process] not how you would like to see the manufacturing system evolve - this will come later

1.2.1.1 Participants

The Manufacturing Strategy Formulation Process Owner and Team identified in task 1.1

1.2.1.2 Sources of Information

Organisation wide

1.2.1.3 Tools and Techniques - Manufacturing Strategy Questionnaire

- Aim**
1. to provide you with a guide when you are drawing your rich picture
 2. to provide an initial audit tool to assess the current situation of manufacturing

The Manufacturing Operation for Warton Unit

How would you describe the current operating philosophy within Manufacturing?

Continuous Improvement	<input checked="" type="checkbox"/>	Total Quality Management	<input type="checkbox"/>	World Class Manufacturing	<input checked="" type="checkbox"/>	Just -In-Time	<input checked="" type="checkbox"/>
Business Process Focus	<input checked="" type="checkbox"/>	Bottle neck Management / Optimised Production Technology	<input type="checkbox"/>	Lean Manufacturing	<input checked="" type="checkbox"/>	Core Competence Management	<input type="checkbox"/>
The Learning Organisation	<input checked="" type="checkbox"/>	Concurrent Engineering	<input checked="" type="checkbox"/>	Multi skilled teams [IPTs]	<input checked="" type="checkbox"/>	Other	<input type="checkbox"/>
Process Improvement	<input checked="" type="checkbox"/>	Enterprise Resource Planning [Baan]	<input checked="" type="checkbox"/>	Get it out by Friday!!!!	<input checked="" type="checkbox"/>		

note to TG - need to add definitions of what you mean by these terms

How would you describe your current Manufacturing Strategy? [If you have one]

	Mostly	Slightly	Not at all
1 Alignment of manufacturing systems with order winners / order qualifiers of different product groups	<input type="checkbox"/>	<input type="checkbox"/>	<input checked="" type="checkbox"/>
2 Continuous improvement to become a world class manufacturing organisation	<input checked="" type="checkbox"/>	<input type="checkbox"/>	<input type="checkbox"/>
3 Development of manufacturing core competences to develop new markets [learning organisation]	<input type="checkbox"/>	<input checked="" type="checkbox"/>	<input type="checkbox"/>
4 Other - please specify	<input type="checkbox"/>	<input type="checkbox"/>	<input type="checkbox"/>

5 tier model - list of components [nothing more at present]

What are the key drivers to the manufacturing strategy?

Cost	3	1
Quality	2	<input type="checkbox"/>
Flexibility	<input type="checkbox"/>	<input type="checkbox"/>
Agility	<input type="checkbox"/>	<input type="checkbox"/>
Leanness	<input type="checkbox"/>	<input type="checkbox"/>
Customer Satisfaction	<input type="checkbox"/>	<input type="checkbox"/>
Delivery Reliability		<input type="checkbox"/>
Delivery Flexibility		<input type="checkbox"/>
Product Reliability		<input type="checkbox"/>
Core competences		<input type="checkbox"/>
Innovation		<input type="checkbox"/>
Other		<input type="checkbox"/>

If that technique/intervention are used to promote the above key drivers?

Total Quality Management	<input type="checkbox"/>	Investors in People	<input checked="" type="checkbox"/>
Benchmarking	<input checked="" type="checkbox"/>	Core competences	<input checked="" type="checkbox"/>
Customer focused	<input type="checkbox"/>	Business Process Re-engineering	<input type="checkbox"/>
Contingency focused	<input type="checkbox"/>	BS 5750 / ISO 9000	<input checked="" type="checkbox"/>
Lean production	<input type="checkbox"/>	Baldrige and other quality awards - EFQM	<input checked="" type="checkbox"/>
Statistical Process Control	<input checked="" type="checkbox"/>	Group Technology	<input type="checkbox"/>
Just In Time Manufacturing	<input type="checkbox"/>	CAD/CAM - CATIA	<input checked="" type="checkbox"/>
Optimised Production Technology - theory of constraints	<input type="checkbox"/>	CAPM	<input checked="" type="checkbox"/>
Automation	<input type="checkbox"/>	Robotics	<input type="checkbox"/>
Best practice / World Class Manufacturing	<input checked="" type="checkbox"/>	Other	<input type="checkbox"/>

How would you describe the overall structure within Manufacturing?

- Multi Disciplined Teams
- Cell Structure
- Focused factories
- Other

What are the issues that cause manufacturing the most pain at present?

- Shortages Quality Costs Suppliers Customers
- Team working Change Finance Delivery Excess Inventory

- Marketing Commercial Projects New Product Development Information Technology
- Processes The organisation Operating Systems Other

Your Products

Please list your major product groups [Warton] / Eurofighter

- A Hawk Final Assembly
- B Tomado Front Fuse
- C EF Development Centre Fuse
- D Boeing - Pylons Rear Fuse
- E T45 Plane Surfaces
- F Spares & Repairs

finished products and bits

Please indicate each major product group on the product - process matrix [Hayes and Wheelwright]

Product - Process Matrix

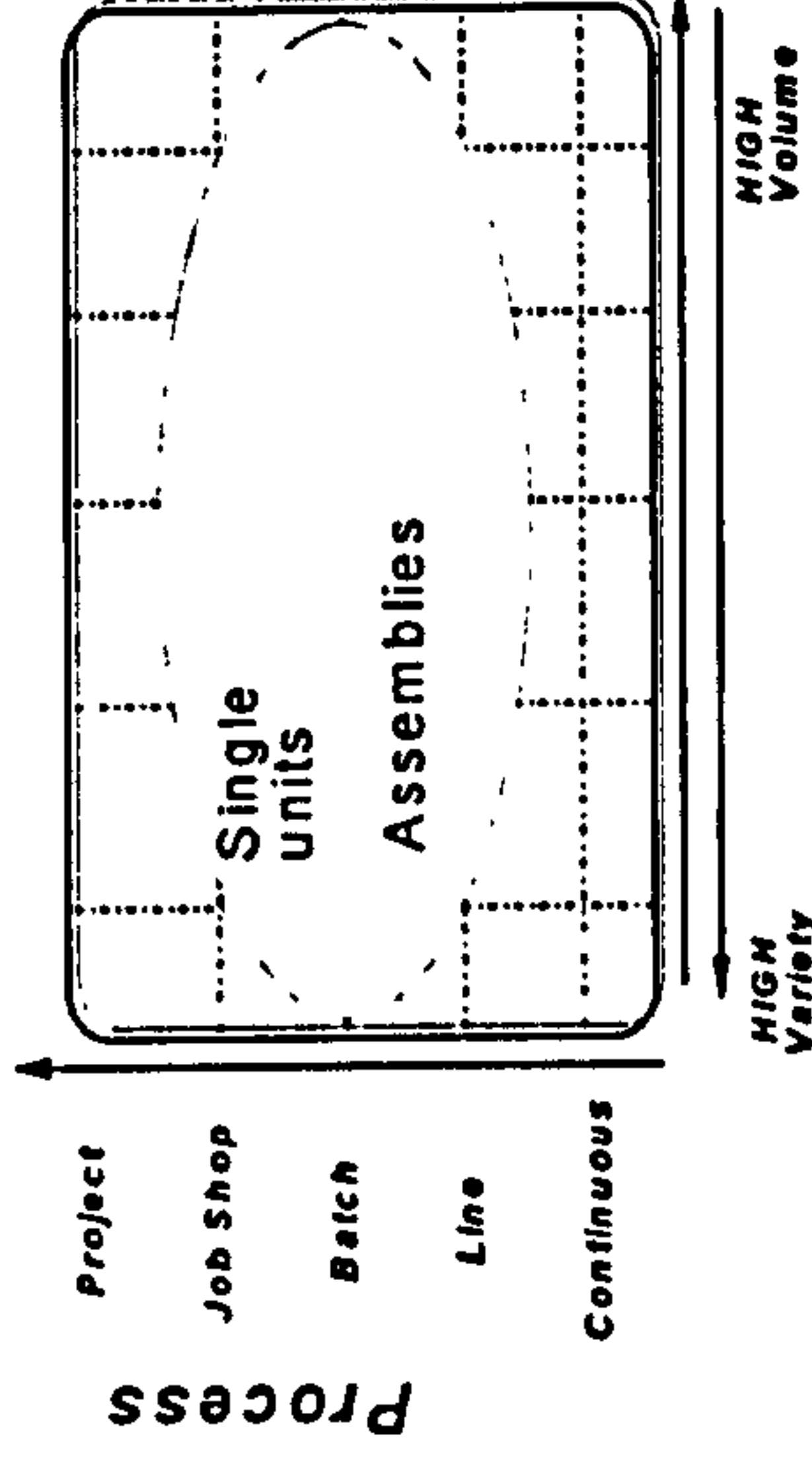

product cost and complexity - key criteria

Runners, Repeaters and Strangers

For each Product Group do you

Product Group	A
Engineer to order	finished product
Make to stock	key spares some details
Make to order	
Assemble to order	✓

Order winners and order qualifiers

Which of these characteristics are absolutely necessary for this product to be considered by a customer in its market place?

[Order Qualifier] please tick all relevant characteristics

Product Group	A	B	C	D	E	F	?	?
Initial Procurement Cost	<input type="checkbox"/>	<input type="checkbox"/>	<input type="checkbox"/>	<input type="checkbox"/>	<input type="checkbox"/>	<input type="checkbox"/>	<input type="checkbox"/>	<input type="checkbox"/>
Life Cycle Cost	<input type="checkbox"/>	<input type="checkbox"/>	<input type="checkbox"/>	<input type="checkbox"/>	<input type="checkbox"/>	<input type="checkbox"/>	<input type="checkbox"/>	<input type="checkbox"/>
Product Quality	<input type="checkbox"/>	<input type="checkbox"/>	<input type="checkbox"/>	<input type="checkbox"/>	<input type="checkbox"/>	<input type="checkbox"/>	<input type="checkbox"/>	<input type="checkbox"/>
After sales service quality	<input type="checkbox"/>	<input type="checkbox"/>	<input type="checkbox"/>	<input type="checkbox"/>	<input type="checkbox"/>	<input type="checkbox"/>	<input type="checkbox"/>	<input type="checkbox"/>
Delivery Reliability	<input type="checkbox"/>	<input type="checkbox"/>	<input type="checkbox"/>	<input type="checkbox"/>	<input type="checkbox"/>	<input type="checkbox"/>	<input type="checkbox"/>	<input type="checkbox"/>
Delivery Flexibility	<input type="checkbox"/>	<input type="checkbox"/>	<input type="checkbox"/>	<input type="checkbox"/>	<input type="checkbox"/>	<input type="checkbox"/>	<input type="checkbox"/>	<input type="checkbox"/>

1.2.2.4 What we have achieved by this stage

- completed questionnaire on the manufacturing operation and its environment
- rich picture of the manufacturing operation and its environment
- a rich source of data for use in stage 6 when we compare what we have with what we want

THIS COMPLETES

THE 'AS IS' SECTION OF THE WORKBOOK

- THE DATA WILL BE ASSIMILATED

AND USED IN

STAGE 6

Stage 3

**1.3 The Problem Situation - The development of the Manufacturing Strategy?
What do we want Manufacturing to achieve [How and What?]**

In soft systems thinking we identify relevant systems which can help us in our problem situation, we must take into account the BUSINESS and MANUFACTURING OBJECTIVES when we identify the relevant systems within manufacturing which will have an impact on meeting those business and manufacturing objectives.

What manufacturing systems would be required and are relevant in order to meet the business and manufacturing objectives?

The Road Map - Stage 3

Objectives
• to develop the manufacturing strategy by naming relevant manufacturing systems that may influence the success of the business strategy

Deliverables
• identification of relevant systems that are key to the alignment of the manufacturing organisation to support corporate objectives.

Examples of Relevant Systems in Manufacturing

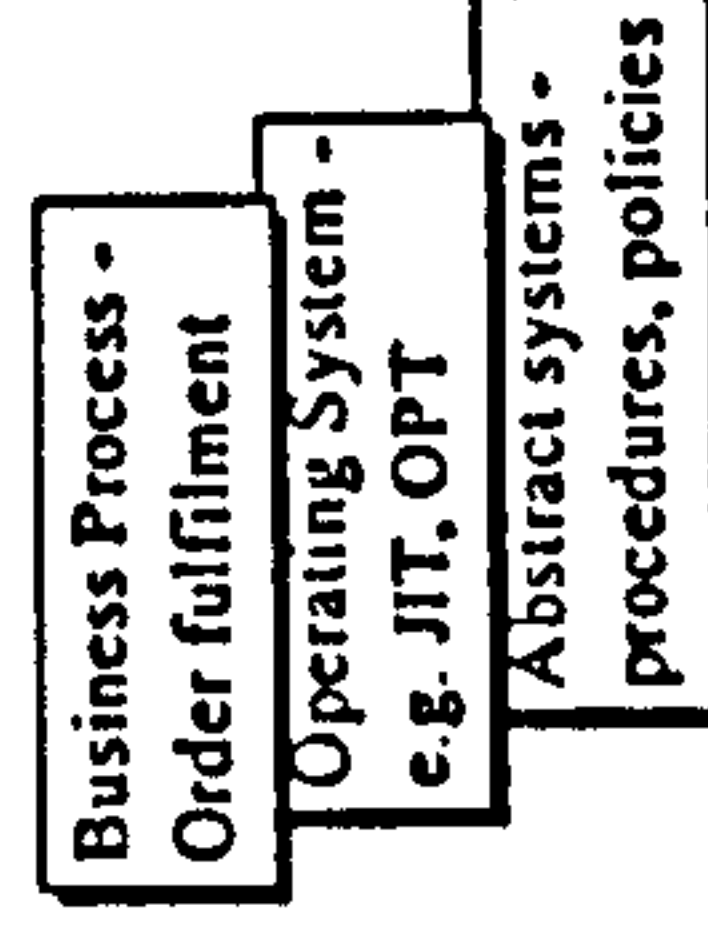

1.3.1 Task 3.1 Develop a statement of what the organisation expects of manufacturing. Identify specific strategic objectives for manufacturing.

This task involves formulating what the organisation and manufacturing expects of the manufacturing operation. The task identifies the direction of the manufacturing organisation and states it explicitly.

The following questions should be considered

What does the business expect of manufacturing?

What does manufacturing expect of the business?

How can manufacturing be aligned most effectively to support corporate and business objectives?

Statement of what the organisation expects of manufacturing

to produce products at or under a defined cost to a prescribed quality and to never fail a delivery

move towards a World Class Manufacturing organisation and to become lean

After developing a statement for manufacturing, several strategic objectives should be identified for manufacturing to aid in the selection of relevant systems. These objectives should be strategic in nature i.e. be stretch goals which support the business objectives and help steer manufacturing in the direction identified above.

Stretch Goals

*30 % cost reduction
50% lead time reduction
100% schedule adherence*

1.3.2 Task 3.1 Identify systems which have a significant role in achieving or supporting the manufacturing strategy. N.B. key enablers

This task involves NAMING the individual systems that will be developed to enable the Manufacturing System to support the business strategy. This task looks at the systems within Manufacturing which will have an impact on the competitiveness of manufacturing and its ability to support corporate and business objectives.

In Soft Systems Thinking the relevant systems chosen can be either task or issue based.

1.3.2.1 Participants
Manufacturing Strategy Formulation Process Owner and stakeholders

1.3.2.2 Sources of Information
Organisation wide
1.3.2.3 Tools and techniques - brainstorming and description of systems

System type	Definition	Example
Human activity system	set of human activities which are carried in order to fulfil a given purpose	a business process
Designed physical system	designed by humans for a purpose	facilities, computer hard ware and software, machine tools, operating systems - CAPM, JIT, MRP, MRP2, OPT etc.
Designed abstract systems	developed by humans to represent 'the ordered products of the human mind'	procedures, policies, codes of conduct, quality policy etc.

Complete the table

System Type	Named Relevant System	Notes
Designed physical system and Human Activity System	Manufacturing control system	
HAS	Get material business process	
HAS	Make product business process	
HAS	Deliver product business process	

Stage 4

1.4 The development of the root definitions for each relevant system selected in stage 3

The Road Map - Stage 4

Developing root definitions for each Relevant System identified

'a system to do x by means of y in order to achieve z'

Customers
Actors
Transformation
Weltanschauung
Owner
Environment

Objectives

- to make the thinking explicit for each relevant system - a root definition is developed for each world view held by the stakeholders within the manufacturing strategy formulation process

Definable

- a root definition for each chosen relevant systems and for each different worldview held about that system
- systems attributes and parameters loosely identified

1.4.1 Task 4.1 Develop root definition for what you want your relevant systems to achieve in terms of supporting the manufacturing objectives identified previously.

1.4.1.1 Participants

Manufacturing Strategy Formulation Process Owner and team

1.4.1.2 Sources of Information

Organisation wide

1.4.1.3 Tools and techniques

After naming any relevant systems it is important to formalise your thinking by using systems concepts. This is done by carefully describing the system as a root definition using the mnemonic CATWOE. All the elements of the systems should contribute to the root definition therefore this stage requires a lot of thought.

The basic form of the root definition is

A system
: to do X
:by means of Y
:in order to achieve Z

The concept of a system and the reasoning behind developing root definitions is to capture the main elements involved in that system. The mnemonic CATWOE is used to develop the root definition and to expose the Weltanschauung [world view] held within that RD.

Customers:

- direct victims or beneficiaries - people or systems which are associated with the inputs and the outputs of the system

Actors:

- person who carries out one or more activities within the system, can also be extended to cover other resources which are crucial to the operability of the system

Transformation:

this will be implied by the facilitator

- fundamental concept of converting some input into some output this is the transformations focused on purposeful action - i.e. organised activities which brings about some sort of change

Weltanschauung:

- the view of the world which makes the human activity system and particular root definition of the relevant systems meaningful
- an activity model is an ideal representation of one particular view of some purposeful action

Owner:

- person, system or agency which has the power to control and ultimately abolish the system under consideration

Environment:

- constraints imposed on the system by the environment

1.4.1.4 An Example of a root definition

A system to enable the alignment of the manufacturing human activity system and designed manufacturing system to support the business strategy, by means of identifying relevant product groups, identifying order winners and order qualifiers for each product group and aligning the manufacturing human activity system and designed system accordingly, and gain competitive advantage by gaining customer satisfaction

Customers: Practitioners i.e. Manufacturing Director, Operations Director
Actors: Manufacturing Director, Senior Managers, Marketing, Customer, Manufacturing Systems Designer

Transformation:

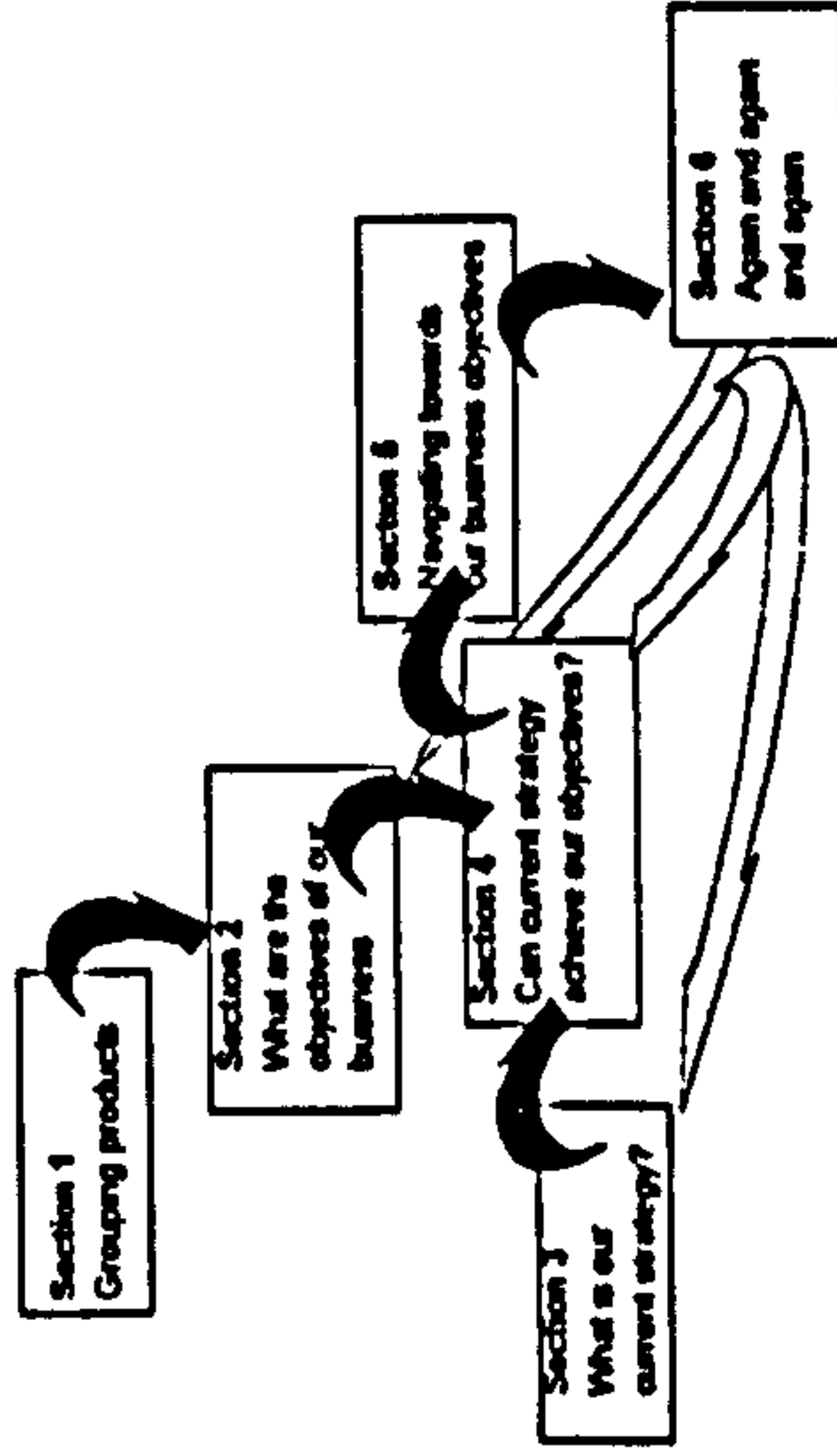

Methodology developed by the Manufacturing Engineering Group Cambridge

Weltanschauung: a market led / customer focused approach is beneficial and a good way to formulate a Manufacturing Strategy

Owner: Manufacturing Director
Environment: Product groupings, order winners and order qualifiers

1.4.1.5 Template for developing a root definition for each named relevant system

Relevant System:

A system to deliver a product at competitive cost, with high schedule adherence and quality with minimum inventory

by means of controlling the flow of materials, information and product

in order to achieve delight the customer

Customers:	Project Boards MoD Procurement End Customer Employees
Actors:	Suppliers Customer Detailed businesses Customer Support Nefma
Transformation:	Raw materials to final product
Weltanschauung:	controlling the flow of material and information is essential for cost reduction and schedule adherence
Owner:	Ross Bradley
Environment:	Vertical integration of the supply chain culture need to implement by first aircraft resource [i.e. the right resource] relationships with suppliers

Stage 5

1.5 The development of conceptual models derived from the root definitions from each relevant system

The Road Map - Stage 5

Objectives

- to develop conceptual models to satisfy the root definitions developed in stage 4 • must satisfy the root definition - no more and no less

Conceptual Models



Deliverable

- conceptual models from the root definitions using systems concepts

1.5.1 Task 5.1 develop conceptual models of the chosen relevant systems using the root definitions and systems concepts developed in Stage 4

Keep the conceptual models at a high level. When feasible and systemically desirable changes have been identified detailed modelling can be done at the implementation stage.

Conceptual Models - what they are and how they can be used

Definition of a conceptual model: a conceptual model is a set of constructs used to help to make a situation more clearly understood. Conceptual models can range from formal modelling methods such as IDEFo to using mind maps to convey key concepts and ideas. Depending on the complexity of the Manufacturing Systems named earlier - will depend on the conceptual model developed. Using systems thinking the following parameters should be determined and developed for each relevant system chosen and each wellenschaung exposed.

1.5.1.1 Template for gathering information for the conceptual models

Named relevant system:	
Root definition:	A system to do _____ by means of _____ in order to achieve _____
C	
A	
T	
W	
O	
E	

The relationship between external and internal variables and the properties of a system can be termed the parameters of a system. Parameters can be categorised as;

System Level 0-1 [it is recommended that 5 - 7 activities are used at any one level. Systems can be explained in terms of hierarchies which enable the more complicated systems to be decomposed at certain level to ensure they are manageable.

Sources	Inputs	Processes	Transformation	Outputs	Receivers	Feedback

Development of conceptual model using IDEFo notation

INPUTS

- Parts list [BoM]
- Lead Time information
- Suppliers Information
- Ordering information
- Task Directive
- Materials
- Order

OUTPUTS

- Product
- Planned omissions
- Certification [CoC]
- Waste / Scrap

Development of conceptual model using IDEFo notation

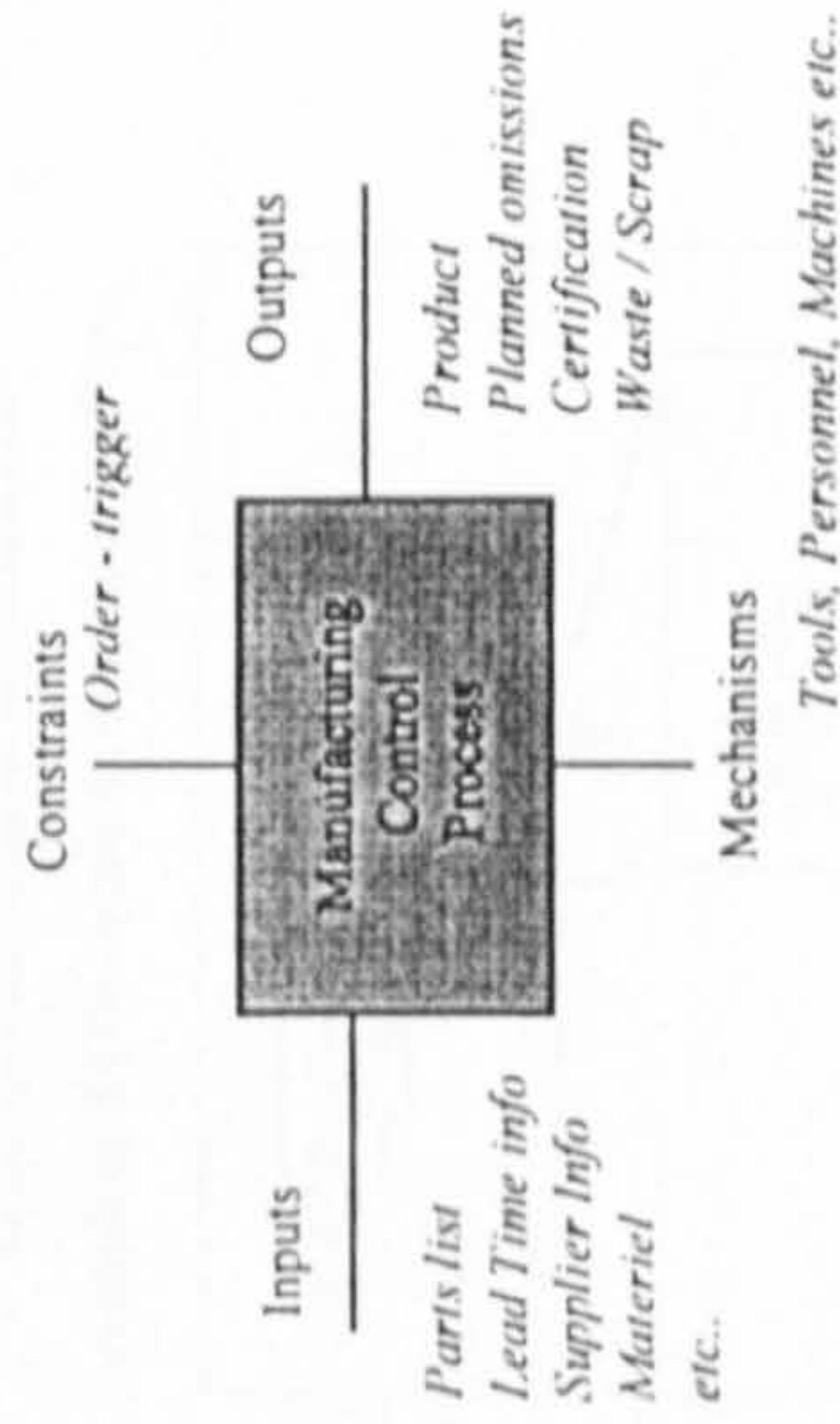

1.5.1.2 Description of Parameters

1. Sources

When considering a manufacturing system there can be many alternative sources for each input. For example sub component suppliers, raw material sources, consultants etc.

2. Inputs (Resources)

Inputs to the manufacturing system are only as good as the available resources. Inputs can be sub-divided into the **basic** inputs and **complementary** inputs. Basic inputs comprise of the goods and services required to produce the basic output and complementary inputs that are resources and constraints that support and control the system.

3. Processes and Transformations

Processes and transformations are the sequences of activities that take place within a system to transform the inputs to the system into outputs.

4. Outputs

Anything exported from a system into its environment is an output. Outputs may take the form of energy, waste, chemicals, information, products etc.

The term "throughput" is often used to encompass all the flows through a system.

5. Receivers

Outputs of a system can be transferred to the receivers. The value of the output from the system can be determined by the value of that output to the receivers. If the output of a manufacturing system is a finished product then the product should meet the needs of the customer.

6. Feedback

Feedback is the function of the system that compares the output of the system with given criterion in order to reduce the deviation between the actual output and the desired output. Feedback can be divided into two different types, intrinsic and extrinsic feedback. Intrinsic feedback involves when the feedback and the control system exist within the system's boundary. Extrinsic feedback involves feedback and control that exists outside the boundaries of the system.

Modelling techniques to consider: Process flows, IDEFo, SSADM, Brown paper with post it notes etc.

An IDEFo model provides a complete, concise and consistent description of the activities and flows that form a system or process. The model is developed from a particular viewpoint for a particular purpose.

The structure of a model

Each model consists of up to five main parts:

- Node index
- Context diagram
- Activity diagrams
- For Exposition Only (FEO) diagrams
- Glossary

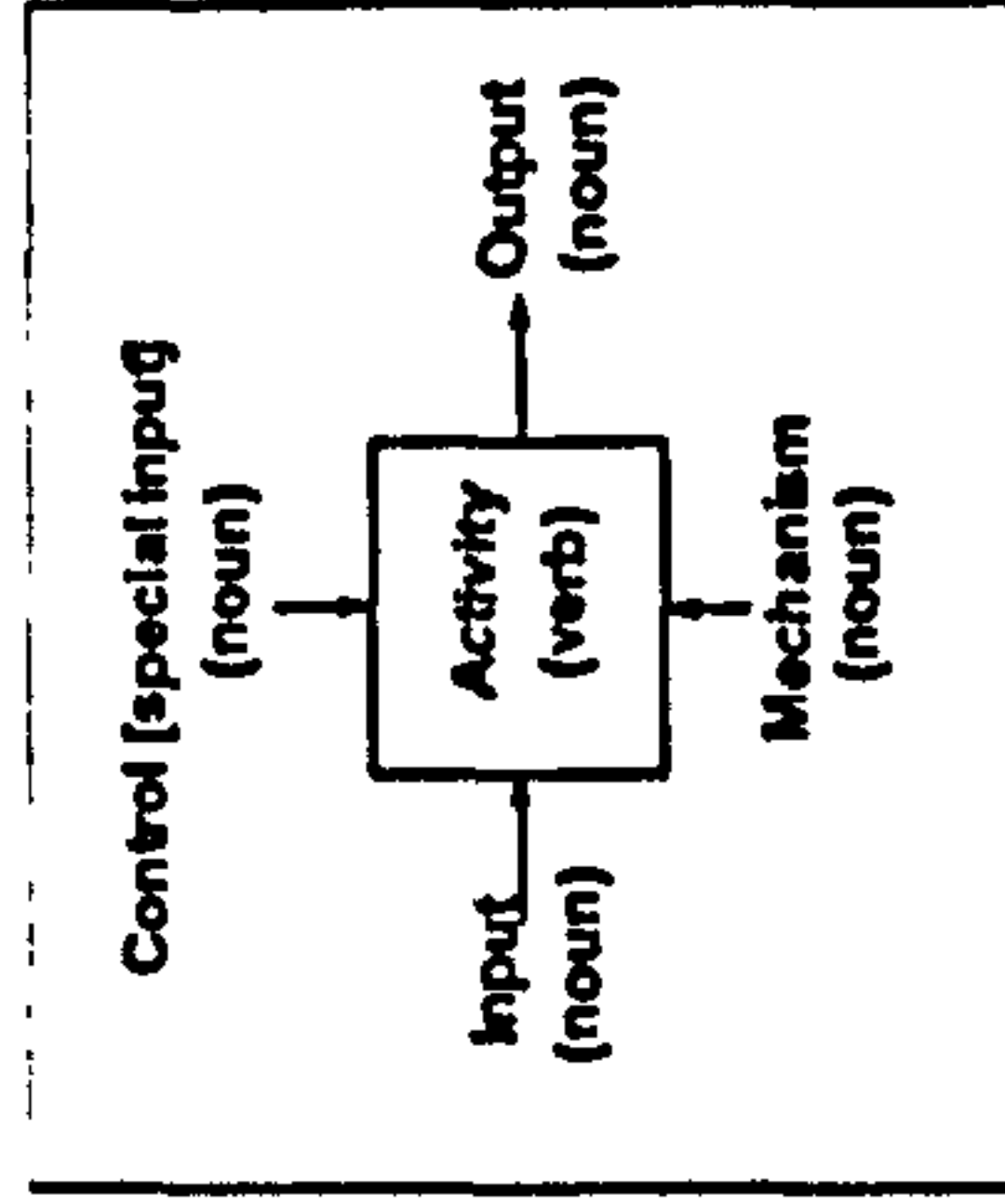

example of IDEFo - useful for conceptual modelling

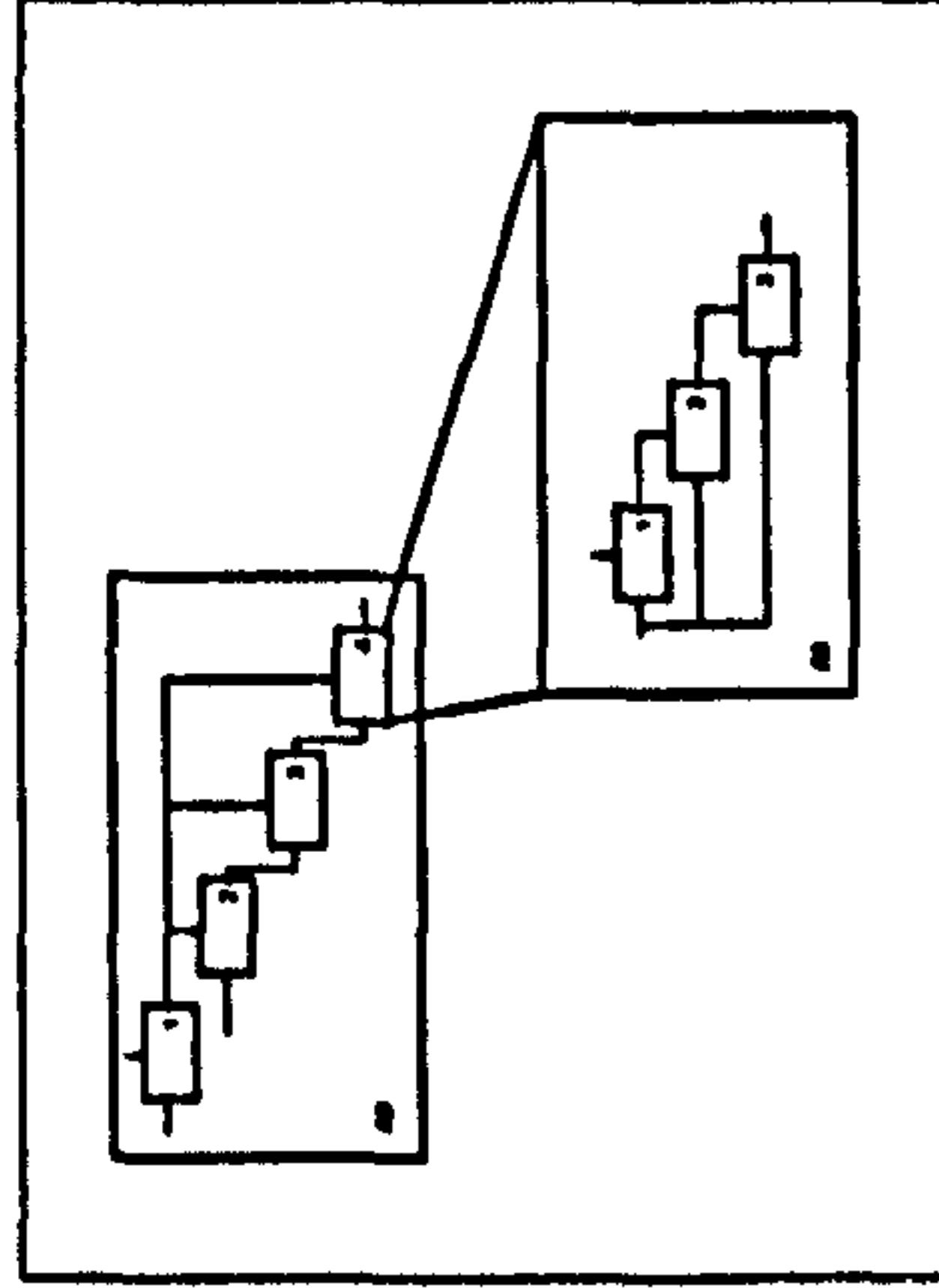

Stage 6

1.6 The comparison of the conceptual models against the real world situation and the 3 Manufacturing Strategy Archetypes.

The Road Map - Stage 6

Objectives

- to compare the conceptual models derived from the root definitions with the real world situation and the 3 manufacturing strategy archetypes to provide a set of strategic issues that need to be addressed to enable manufacturing to support business and corporate objectives.

Differences between conceptual models the 3 manufacturing strategy archetypes and the real world

Deliverable

- Completion of comparison tables
- Completion of Archetypes Questionnaire

1.6.1 Task 6.1 Complete Comparison Table/s

1.6.1.1 Participants

Manufacturing Strategy Formulation Process Owner and stakeholders

1.6.1.2 Sources of Information

Conceptual models
Rich Picture Questionnaire

Rich Picture
 Current process models
 Current organisational documents

**1.6.1.3 Tools and techniques - Example of a comparison table
 needs to be developed**

A matrix for comparing a conceptual model with a real world situation [p 42 Checkland]1990

Activity	Exists or not in real situation?	How is it done?	How is it judged?	Comments
1			criteria and current judgement	new 'what's alternative hows ideas about changes
2				
3				
Links				
Activity and links from models e.g. 1 - 2 2 & 3 - 4				

Questions to ask:

- Does this activity, or this relationship, exist in some time?
- How is it done and by whom?
- Is it a source of concern or is it regarded as well done?

1.6.2 Conceptual Models of the 3 Manufacturing Strategy Archetypes

1.6.2.1 The market led - customer focused conceptual model for Manufacturing Strategy

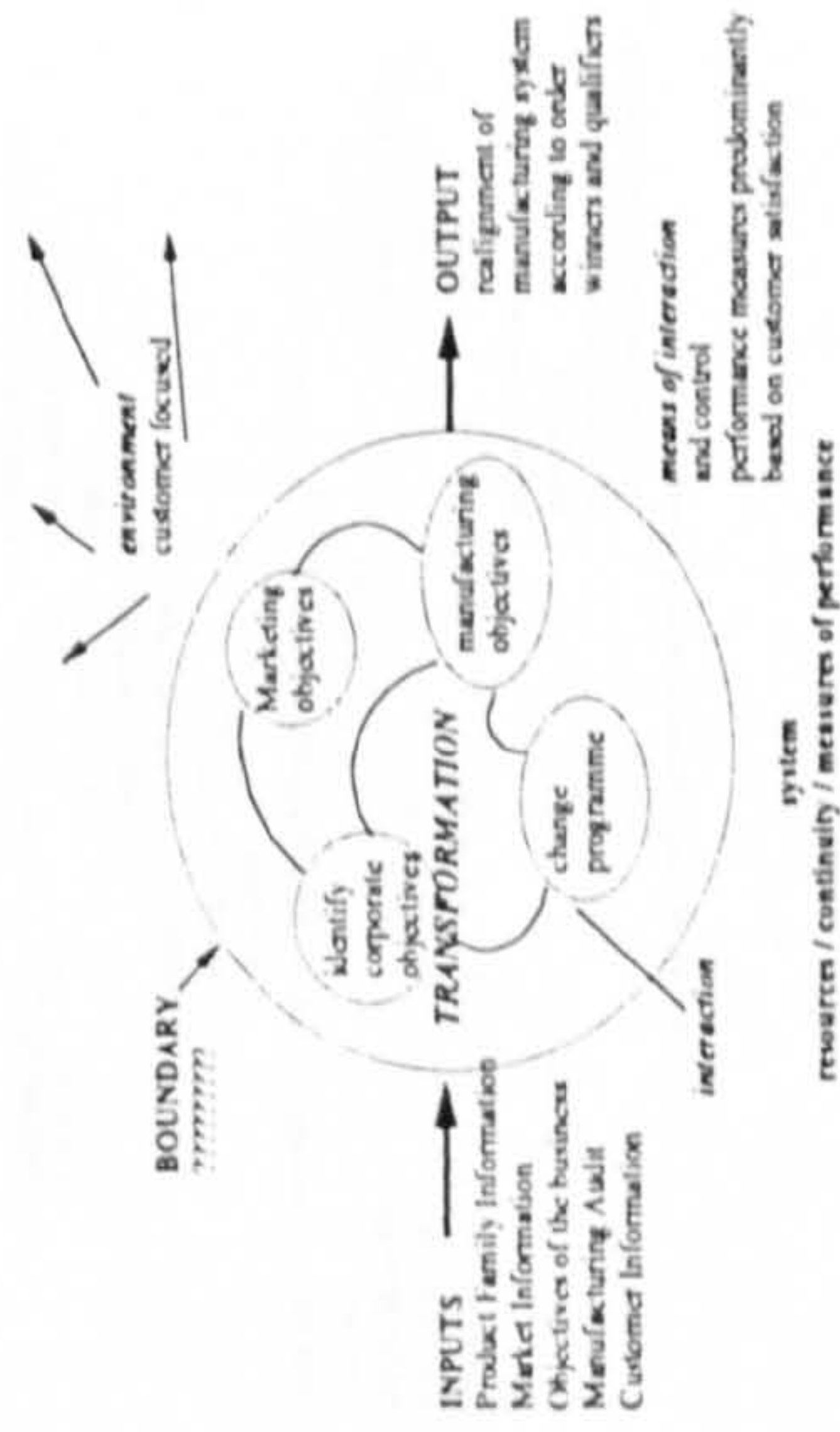
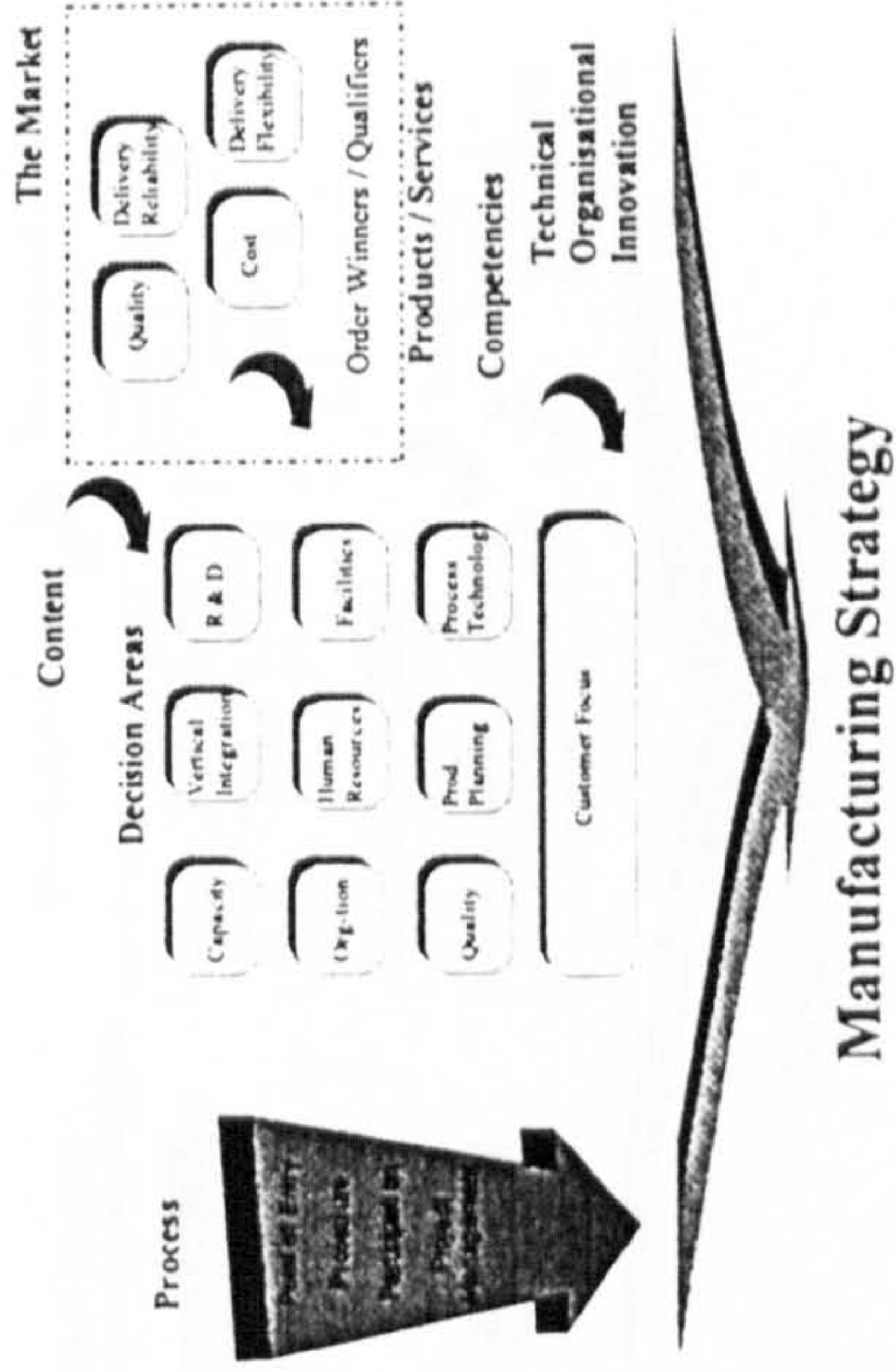

1.6.2.2 The best practice - excellence model for Manufacturing Strategy

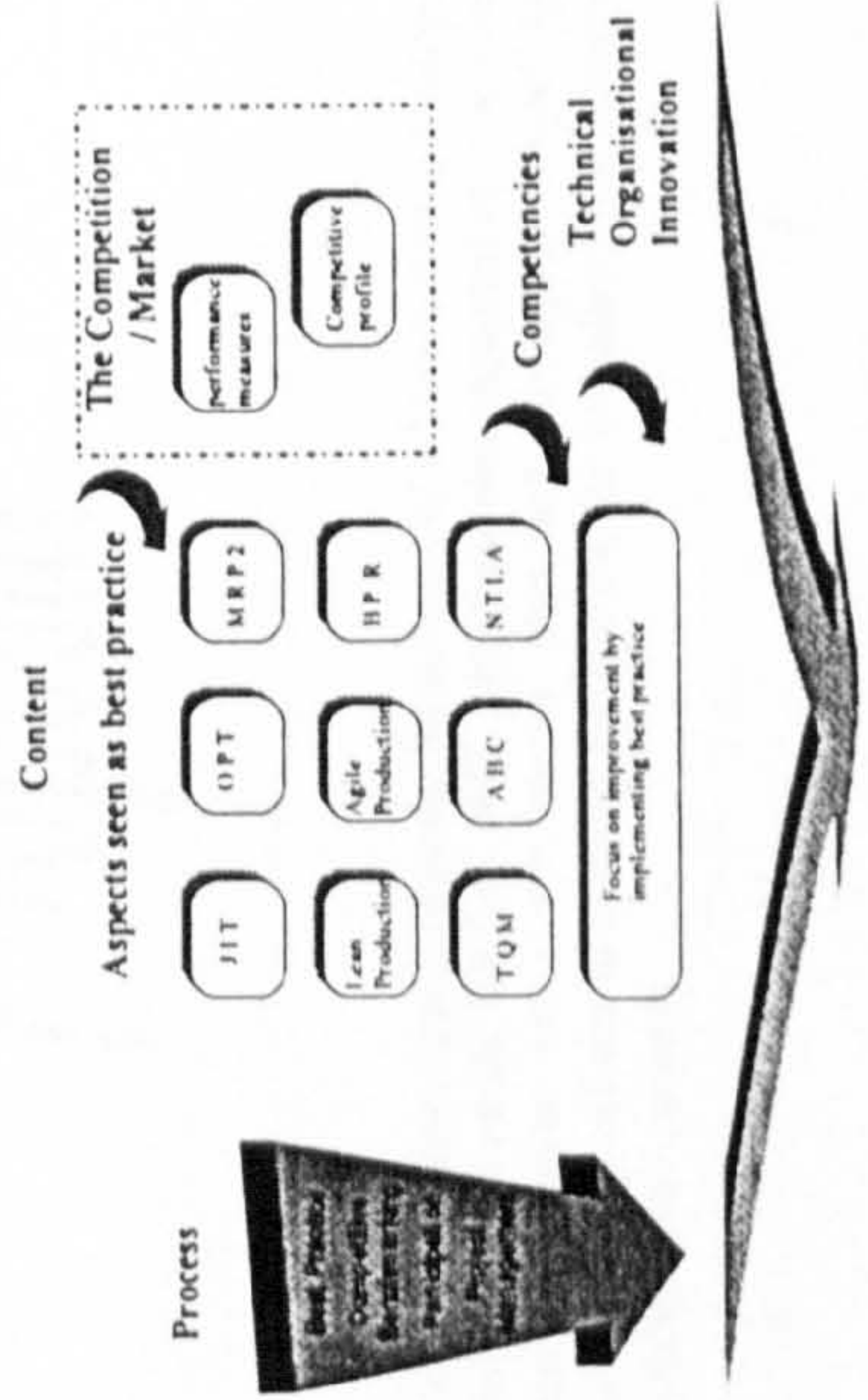

Manufacturing Strategy

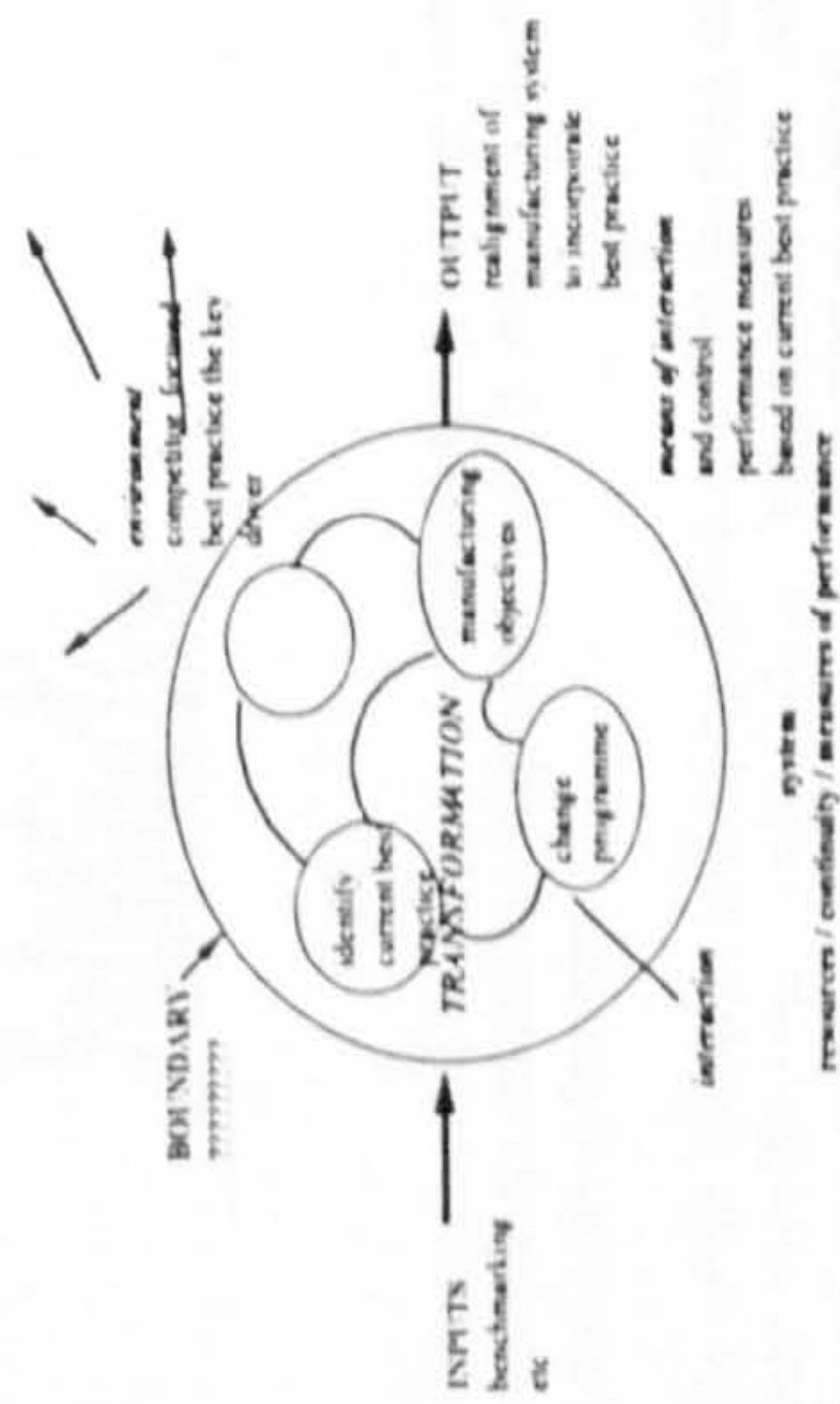

1.6.2.3 The knowledge based / learning organisation conceptual model for Manufacturing Strategy

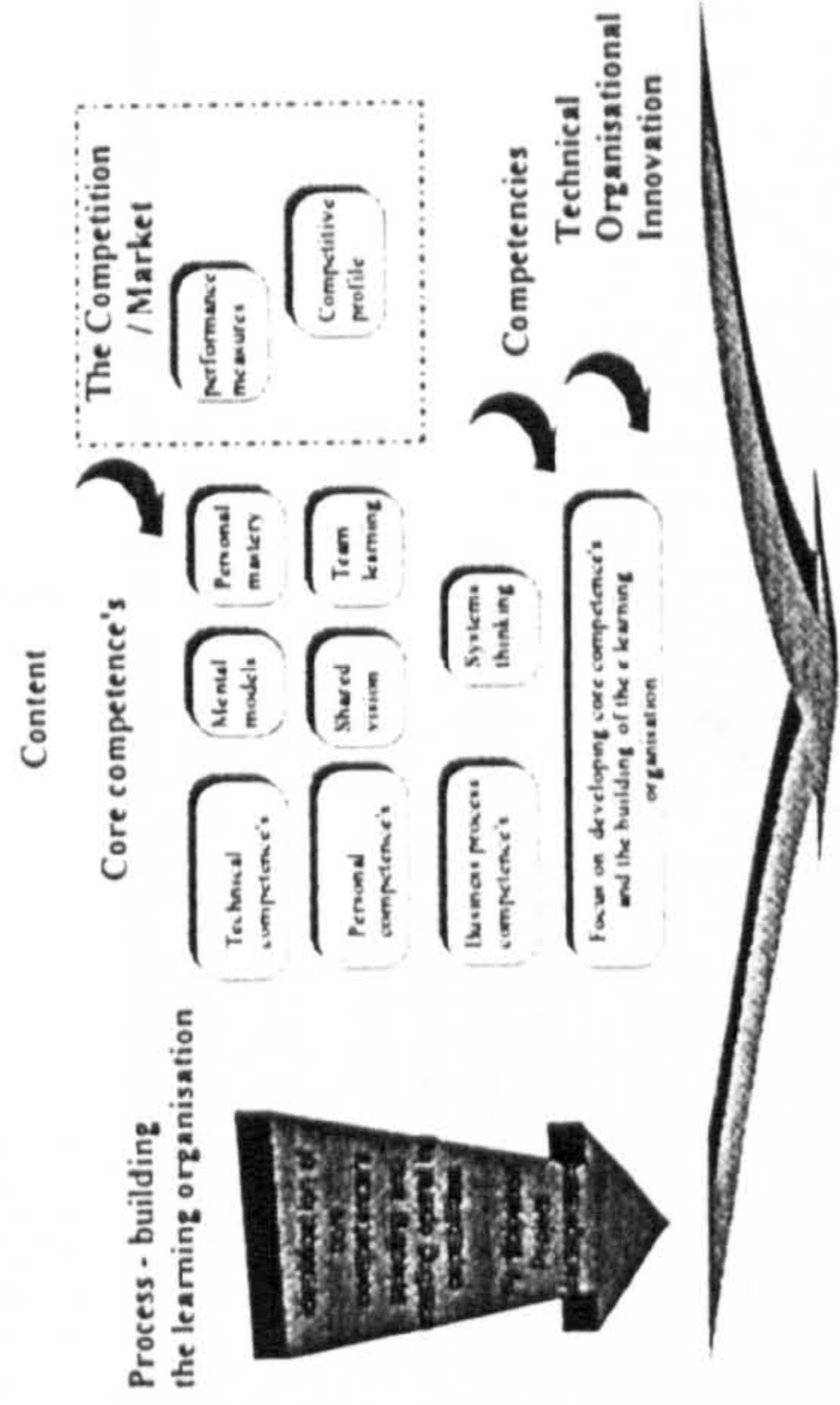

Manufacturing Strategy

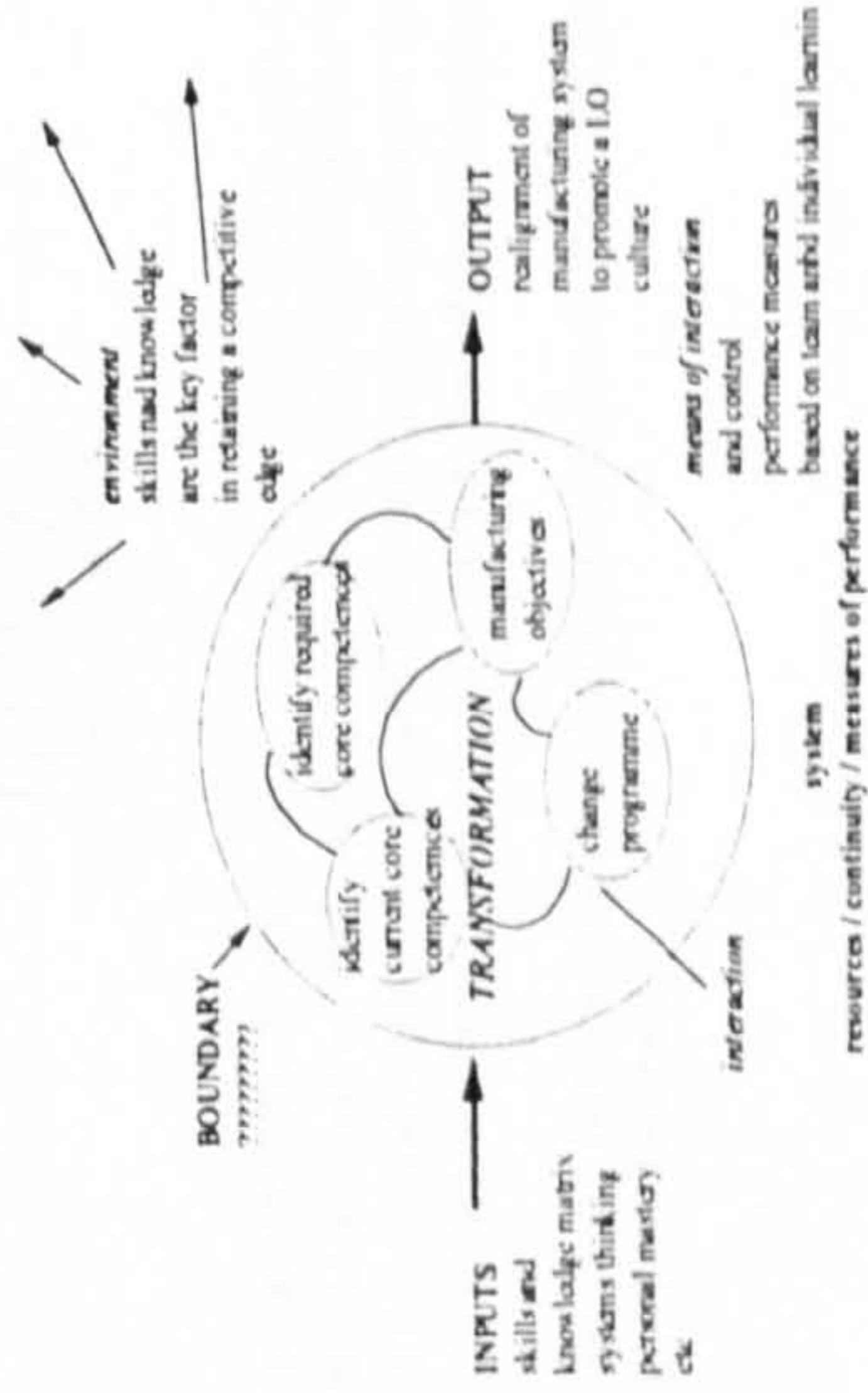

Proposal

Following the Soft Systems Approach to the formulation of a Manufacturing Strategy workshop held at Filton on the 9th July 1997, a proposal was requested to widen the audience and participation within the Warton Unit and Eurofighter Project by allocating an away day off-site to develop the Eurofighter Manufacturing Strategy using the Soft Systems Approach.

Introduction

The Soft Systems Approach to the formulation of a Manufacturing Strategy workbook leads the participants through several key stages and thought processes to develop an implementable Manufacturing Strategy.

The key philosophy of the approach is the stimulation of debate amongst the key stakeholders within Manufacturing whilst taking into account the different worldviews or perceptions that the key manufacturing stakeholders may hold.

Participants

The following participants were identified as key team members and manufacturing stakeholders who should be invited and encouraged to attend.

- Ross Bradley
- Pete Blundell - Manufacturing Operations Manager
- Integration Team - IPTs
- Trevor King - Customer Support Directorate
- Manufacturing Managers

Format

It is proposed to form 3 groups of 5 - 7 participants to debate each stage of the workbook. At the end of each stage the groups would come together in a plenary session to debate and reach agreement and consensus before moving to the next stage. The groups would be changed around periodically to stimulate discussion.

The groups would each be assigned a facilitator who would guide the group through each stage of the workbook

Timing

The timing for the workshop would be as follows

Activity / Subject	Timing	G or P
• Introduction	9.30 - 9.40	Plenary
• Section 1 - the theoretical base	9.45 - 10.15	Plenary
Manufacturing Strategy Soft Systems Thinking [SST] The Soft Systems Approach to Manufacturing Strategy Formulation, Benefits of using the approach, Issues to be considered whilst following the methodology		
• Section 2 - The Soft Systems Approach to Manufacturing Strategy	10.30 start	Groups
• Does the Organisation see the need for change?	10.30 - 11.15	
• <i>Debate, discussion and consensus</i>	11.15 - 11.45	Plenary
• Formulation of a Manufacturing Strategy [The real world problem situation - unstructured]	12.00 - 13.00	Group
• LUNCH	13.00 - 13.45	
• <i>Debate, discussion and consensus</i>	13.50 - 14.20	Plenary
• The Problem Situation - The development of the Manufacturing Strategy? <i>What do we want Manufacturing to achieve [How and What?]</i>	14.30 - 15.00	Group
• <i>Debate, discussion and consensus</i>	15.00 - 15.30	Plenary
• The development of the root definitions for each relevant system selected in stage 3	15.40 - 16.30	Group
• <i>Debate, discussion and consensus</i>	16.35 - 17.00	Plenary
• End of day 1		

• Review of day 1

9.30 - 10.30

Plenary

N.B. the time period between day 1 and day 2 should allow the development of the conceptual models from the root definitions [still at a high level]

- Development of the conceptual models from the root definitions to be completed in between day 1 and day 2
- The comparison of the conceptual models against the real world situation and the 3 Manufacturing Strategy Archetypes. 10.45 - 12.00 Group
- *Debate, discussion and consensus* 12.10 - 13.00 Plenary
- LUNCH 13.00 - 13.45
- Identification of feasible and desirable changes to the Manufacturing Strategy System - output the direction and journey of the Manufacturing System - The Manufacturing Strategy 14.00 - 15.30 Group
- *Debate, discussion and consensus* 15.40 - 16.40 Plenary
- Summing up - comments etc. 16.50 - 17.30 Plenary

Resources

It is recommended that the following resources are provided

- Off site location for 2 days preferably with 1 - 2 weeks in-between to allow the development of conceptual models
- 3 groups of 5 - 7 participants
- 3 facilitators

1.1. Case N

The validation carried out with Case N was gathered from workshops and meetings between April and August 1998

1.1.1. Participants

Manufacturing Director
Marketing Manager
The researcher

The data was validated by the participants who read the reports for each meeting provided feedback and signatures.

1.2. Validation approach

The participants were led through the approach. This study was the most detailed of the three and has provided the organisation with an action plan and key objectives which are to be implemented.

The full process is reported in the attached documentation. At the time of writing the development of the organisations manufacturing strategy is ongoing.

General comments received

'useful to talk through the issues and to understand the different approaches of manufacturing and marketing;
'good process'

G & S SMIRTHWAITE Ltd

Manufacturers of Furniture & Equipment
16 Wentworth Road
Heathfield
Newton Abbot
Devon, England.
TQ12 6TL

Telephone: +44 (0) 1626 835552

Fax: +44 (0) 1626 835428

Tammy Greswell
MABS
University of Plymouth
Drake Circus
Plymouth

19th August, 1998

Dear Tammy,

Feedback Report of the Application of a SBS model for G & S Smirthwaite

IDEFO definition of operations within G & S Smirthwaite, concentrating *upon get order* process. Within the phase identification of current limitations were addressed with recognition of future process development. The approach provided the framework for a clear, focussed programme with detail analysis of specific areas developing as the model progressed.

This model framework has allowed us to address the present systems condition within the company from a clear viewpoint, allowing us to structure future systems planning using the model to date. We feel that using the model we have achieved a much more impartial and focussed view of the company, aligning our current perceptions and views within the framework.

A critical aspect of the approach has been the capacity of the facilitator to encourage and focus the thought process with regard to future development. The approach has raised the awareness of significant barriers to future development with the highlighting of critical areas.

At this stage of the process clear steps have been made in aligning future company development planning based upon a structured and focussed approach. Future direction of the process and application of the framework will be dependent upon maintaining the current impetus and remaining focussed upon the target objectives.

The actions and support of the facilitator will be crucial in maintaining this focus.

The approach, to date, we felt has been successful in aligning current and future company system requirements and in providing a platform on which to address issues critical to the future development and growth of the company.

.....
R. J. Burrows
Director of Manufacturing

.....
A. Williams
Sales Manager

Validation Case N

Planned sequence to develop manufacturing strategy

1. Identification of current situation – people, processes, technology, market, products order winners and order qualifiers [workshop 1 - 11th May 1998 – complete]
 2. Visioning – developing vision, objectives – direction of manufacturing in the next 12 months and 5 – 10 year horizon Identification of relevant systems to enable the achievement of the goals identified above [workshop 2 – 15th May 1998 - complete]
 3. Systems development – [Systems world] – develop root definitions and conceptual models for relevant systems using systems parameters etc [workshop 3 – 22nd May 1998 – 2nd June 1998 – ongoing]]
 4. Gap analysis – compare systems with current situation [rich picture] – identify systemically and culturally desirable changes [11th June]
 5. Action plan [to be arranged]
-

Workshop 1 – 11-05-98 - Identification of current situation – people, processes, technology, market, products order winners and order qualifiers

Current situation

People

Discipline

Approach people take, attitudes towards certain roles and jobs, roles may not be defined, overlap between roles, unaware of what is expected of them, Could link to plans and objectives

Career path

Based on how the company grows

Skills and knowledge

Wide variety – aspirations are different

Skilled cabinet makers to unskilled manual labour – some with learning difficulties

Management – few management skills caused by a lack of training, experience and previous concepts of how people should work

Organisation

Open – more defined

People tend to stay in their own area

'Wooden fortresses'

a few key people cross over – bit of multi skilling

key people can see where they fit in and that there is a future

Culture

Blame culture – if something goes wrong its WHO not HOW and WHY.

Developed from a school boy culture the MDs approach compared to that of a classroom – people see how far and how much they can get away with

Improving

Key people [culture champions] are people who the rest take the lead from – not necessarily positive

Them and us scenario – no real reason behind it – comes from the blame culture

Good atmosphere – less confrontational than before – core staff developed competencies required

Training

Lack of training

OJT – fast appreciation of work – straight forward and depth of knowledge can be easily transferred to other areas – key skills overlap

New starters – OJT

No structural plan to develop knowledge and skills

Individual perceptions of what their roles are and what they should be doing

Not aware of the processes – leads to a break down

Rewards and recognition

No reward schemes or structure

Pay review every 6 months

Comparative low wage

One to one recognition

Used to be based on attendance

More open atmosphere and attitude to the performance of the company

More transparency

Technology

4 main systems

- CNC CAD
- Sales order processing
- Manufacturing database
- Finance – SAGE

General

None of the systems talk to each other - will be able to

Appropriate for what they are used for

Developed for a basic manufacturing system

Waste packaging legislation – above a certain turnover must be recycled

CNC CAD

Critical technology

No plans to integrate

References to company identifications

Process – A3 and A4

No links – deliberate as can not afford for the system to go down

Provides an advanced design capability [CNC and CAD operator and deputy MD

2 people trained to use it - others can converse with it

Sales order processing

For receipt of orders, generation of worklists and sales reporting

Manufacturing database

Stock control and management

KANBAN generation and management

Bill of materials – assembly, component, product and costing

Standalone – 2 linked machines

Company developed system

Needs to be normalised

Finance – SAGE

Purchase ledgers

Pay roll

All accounts

Standalone

Want to link it to manufacturing database

Will be upgraded

Falls down [network problems]

Limited reporting capability

Limited financial measures

Others

AUTOCAD – design of components not directly linked to the CNC / CAD system

Network – ring network – needs to be upgraded

Scales

CNC router

Machining tools

Teleprinters

Processes

	activity	inputs	outputs	mechanisms	Issues
A1	Plan orders – preparation for generation of orders	Worklist Existing workload Materials Resources Resources status	Order generated Stock status updated Purchase requests Resource requests Kanban request	Production manger Historical data	No formal planning or scheduling or forecasting
A2	Generate kanban	Informal planing Stock status Request for kanban	Kanban card Cutting lists Data to manufacturing database Batch and number quantities	Hand written Manufacturing database Production manager CNC operator Deputy MD	Entry if incomplete information onto the system
A3	Make components and assemblies	Kanban Materials Resources Cutting lists Associated componentry	Component Completed information of product record Waste materials	Batch completion record KANBAN Machine tools Operators Manufacturing database Production manager Deputy MD CNC operator Bob	BOM not always used
A4	Finish components and assembly	Components / assemblies Materials Resources KANBAN	Finished polished components Waste material	Operators Dispatch manger Assembly operator KANBAN cards	Storage areas Loss of KANBAN in this area Bottleneck Labour
A5	Final assembly of orders	Work list Purchased items Components / assemblies from stores	Product / order Waste materials Completed signed Worklist	Assembly operator Worklist	Incomplete orders Lack of assemblies in stores and purchased items Late assembly
A6	Check and dispatch	Order Packaging material Packaging documents Delivery note	Packed and checked order Despatch documents Waste material	Packers Work list Sales order staff Despatch controller	Incomplete orders Poor packaging Conflicts with sales Lack of packaging material

Current market

Product groups

Standard	100% assy to order	Heathfield – standard product, different sizes, standard accessories – customize if appropriate Conductive
Customs	Make to stock 40% Make to order 60 %	Mayfield – designed specification from a modular design, different sizes
Sub contract work	Design / engineer to order	CNC based - high variety and large quantities for both Non CNC based
Commodes	Make to stock 95%	Standard product
BLISS	Assemble to order	

Order winners and order qualifiers

	Order qualifiers	Order winners
Standard - Heathfield	<ul style="list-style-type: none"> • Price • Quality • Support and assessment • Materials • Reputation • Lead time 	<ul style="list-style-type: none"> • Price • Perceived reputation
Standard - conductive	<ul style="list-style-type: none"> • Quality • Materials • Price • Reputation • National and international • Lead-time 	<ul style="list-style-type: none"> • Price • Quality • Reputation
Customs	<ul style="list-style-type: none"> • Flexibility of design • Lead time • Reputation • Assessment and support • After sales service • Price 	<ul style="list-style-type: none"> • Flexibility of design • Lead time • Reputation
Sub contract work	<ul style="list-style-type: none"> • Total package – design to manufacture • Lead time • Price • Flexibility 	<ul style="list-style-type: none"> • Lead time • flexibility
Commodes	<ul style="list-style-type: none"> • Price • quality 	<ul style="list-style-type: none"> • quality
BLISS	<ul style="list-style-type: none"> • Flexibility of design • Cost • Reputation • Lead time • Chair design 	<ul style="list-style-type: none"> • Price • design

Competitors

Direct

Similar product ranges – Jenx, Leckey, Taylor Therapy, Rafton

Indirect

Product to do similar things

Abroad

Product imports

Barriers to entry

Reputation

UK market is saturated

World market is emerging

Quality

Service

Major customers

General

UK

Special schools

Health departments

Mail order

Private sales

Private schools

Grant funded

Charities

Health authorities and hospital

Distributors

Private sales

Export

Distributors

Private sales

Customs

Full time agents – 6 representatives work on commission to occupational therapists, health authorities, and schools – carry out assessments etc

Market environment

One to one contact

Opportunities

Subcontracts – capacity on machine

Total package – AI to design chairs

Opportunities in export market

Workshop 2 – 15-05-98- Part 1 - Identification of current situation – people, processes, technology, market, products order winners and order qualifiers [update]

Current Market

Product groups

Standard	100% assy to order	Heathfield – standard product, different sizes, standard accessories – customize if appropriate Conductive
Customs	Make to stock 40% Make to order 60 %	Mayfield – designed specification from a modular design, different sizes
Sub contract work	Design / engineer to order	CNC based - high variety and large quantities for both Non CNC based
Commodes	Make to stock 95%	Standard product
BLISS	Assemble to order	

Order winners and order qualifiers

	Order qualifiers	Order winners
Standard – Heathfield BEST SELLING PRODUCT 20% OF SALES	<ul style="list-style-type: none"> • Price • Quality • Support and assessment • Materials • Reputation • Lead time • Functionality 	<ul style="list-style-type: none"> • Price • Perceived reputation
Standard – conductive [very close to the market place] 20 – 25%	<ul style="list-style-type: none"> • Quality • Materials • Price • Reputation - National and international • Lead-time 	<ul style="list-style-type: none"> • Personal – perceived value • Quality • Reputation
Customs Brookfield and Mayfield	<ul style="list-style-type: none"> • Flexibility of design • Lead time [3 weeks] • Reputation • Assessment and support • After sales service • Price 	<ul style="list-style-type: none"> • Flexibility of design • Lead time • Reputation
Sub contract work [repeat orders – ability to work with the specifier is important]	<ul style="list-style-type: none"> • Total package – design to manufacture • Lead time • Price • Flexibility 	<ul style="list-style-type: none"> • Lead time • Flexibility • Price
Commodes	<ul style="list-style-type: none"> • Price • quality 	<ul style="list-style-type: none"> • Price
BLISS	<ul style="list-style-type: none"> • Flexibility of design • Cost • Reputation • Lead time & Chair design 	<ul style="list-style-type: none"> • Price • Fundamental design • Only chair of its type

Delivery flexibility is very important – dispatch is seen on its own

Competitors

Direct

Similar product ranges – Jenx, Leckey, Taylor Therapy, Rifton – religious organisation

Indirect

Product to do similar things

Abroad

Product imports

Barriers to entry

Reputation

UK market is saturated

World market is emerging – economic and financial implications

Quality

Service

Major customers

General

UK

Special schools – partly residential – public authorities, charities, and trusts

Health departments

Mail order

Private sales

Private schools

Grant funded

Charities

Health authorities and hospital

Distributors

Social services

Education departments

Export

Distributors

Private sales

Target the key specifiers

Trade forums and fairs

Exhibitions

Customs

Full time agents – 5 agents, 1 full time representative - work on commission to occupational therapists, health authorities, and schools – carry out assessments etc

Market environment

One to one contact

Occupational therapists

Opportunities

Subcontracts – capacity on machine

Total package – AI to design chairs

Opportunities in export market

Phase 2 - Visioning – developing vision, objectives – direction of manufacturing in the next 12 months and 5 – 10 year horizon. The identification of relevant systems to enable the achievement of the goals identified above

Vision

Market opportunities

Export market – very important – spread on exports needs to be realistic

Appropriate packaging

New designs – Heathfield

Develop seating from child to adult

Develop current products

Total packages – AI design

Metal and composites

Current business strategy

- No formal business strategy
- No formal objectives

Extend markets to Europe, USA, and Japan

Managed steady growth to 1M turnover in 1 year

Develop conductive education side

Develop core competencies in metalworking and composites

Current manufacturing strategy

No formal current strategy as such

Cost reduction strategy [CNC router – cost reduction, flexibility, and efficiency]

Logical progression of investment

Philosophy – get it out of the door ‘bob understands all that – as long as it doesn’t affect me!’

Comparison to the three archetypes –

Best practice – a long way away – people are working towards it

Knowledge based – basically how the company has evolved

Customer focused / market led – not how manufacturing has developed

Key drivers – identified by manufacturing director

Lead times – achieved by monitoring and measurement – awareness of the requirements, need to reduce downtimes and complexity
Quality – achieved by training - OJT
Flexibility – not being promoted at the moment

Manufacturing Organisation

Very individual – responsibility for range or product with one person
Manufacturing
Assembly **C R A F T**
Final assembly –

Main painful issues regarding manufacturing

Cramped conditions
Costs
Attitudes – perceptions of what people are doing
Limitations on processes and capacity – bottlenecks e.g. dipping
Carriers – how the product arrives at the customer

Marketing view of manufacturing

Seen as the key element within the organisation
Marketing critical success factors – quality, lead-times, right first time, repeatability
Constrained by the manufacturing views of the founder – i.e. timber as opposed to metal

General

Serialisation of the product
Tracability

What should manufacturing deliver – marketing perspective

Lead time – below the expected norm i.e. less than or equal to three weeks
Quality – visual, utilisation, functionality
Delivery – packaging and customer receipt
Customer's perception – looks good when it arrives
Really should exceed expectations
Dispatch and delivery is very important

What should manufacturing deliver – manufacturing perspective

Quality – culture, product and processes
Supply chain
Process control
Right technologies
Flexible structure

Stretch goals identified

12 months

Quality	drawings of all products on computer and paper based [product] return of damaged goods reduced by 75%
Quality management system	To be implementing in 12 months
Lead times	3 weeks for 85 % of orders
Delivery reliability	Percentage damaged in transit [0.05%] Identification of all causes of damage
Health & Safety	Awareness of issue – 100% of staff trained, procedures in place, identification of hazards, awareness,
Costing	Confidence in costing

Identification of relevant systems

IT System
Quality Management System
Strategy formulation system
Operate system

Phase 3 – Systems development

Development of quality management system – the 'to be' system

Root definition

A quality system to control processes and operations within the company, by means of identification, structure and validation of the processes and operations in order to achieve product and process conformity [requirement levels] and to identify if the production processes are out of control, conform to requirements [legal] and to delight the customer

Note – need the confidence to deliver what we say we will deliver

Customers

All employees and external customers – want to have confidence and visibility

Actors

All

Transformation

Information - confidence about processes and products

Worldviews

1 – identification and quantification of operations [Bob]

2 – product development which does a job that is aesthetically pleasing as possible and it gets to the customer in a condition, anticipated leaving the factory – features , customer perception, reliability of the final product – fit for purpose

3 – customer perception – what they see as ISO 9000

4 – vertical integration

Owner

MD, Manufacturing director, everyone needs to own the system

Environment

Other departments who do not view the quality factor

Activities	Inputs	outputs	mechanisms	Issues
Identify QMS objectives	Current operations Existing documentation Information on best practice Current knowledge within organisation Company perceptions of ISO	Required process identified and documented Process agreed Single company view	ISO 9001 template Project manager / champion Employees Presentations Focus groups	Change Ownership Identification of problem areas Resource – finance time people Market Family owned business
Develop the QMS	Process identified and documented Information from the operate process Single company view Operations information	Procedures complete Awareness of requirement Process measures identified Project management plan	ISO 9001 Champion Training modules Project management plan	No spare people Doesn't go out of control Manageable Flexible Simple Ownership Resource communication
Implement QMS	Procedures Awareness of requirement Process measures Project management plan	QMS operational Employees trained	Project management plan Walkthrough Champion Focus groups	
Use the QMS	Procedures Associated documents Regulations Employees trained	Products made to spec [customer requirements] Performance measures Audit reports Continuous improvement plan	Paper based IT system Customer visits Audits Training modules Project management plan	margins very slim Payment and investment for this is not straight forward Who drives it, who keeps it going expectation
Get accreditation	QMS documents and policies Trained employees Internal audit reports	Certificate Recognition – internal and external Feedback Corrective actions Progress report	Accredited body External consultant Auditors Quality circles 3 rd party assessors	Timescales No of products Implications of failure? How accreditation is promoted
Maintain QMS	Procedures Audit timetables Internal controls traceability Q Controls recommendations Feedback from external bodies results of internal audits	Action plan Development plan for systems Updated documentation Trained and aware staff Measurable results Performance measures – financial and non financial	Employees Quality circles Reviews Results	Drawings Produces control Positive Needs to be sold Implications need to be shown Expectations need to be set Legislation Environmental management

Development of the operate processes – the ‘to be’ system

Root definition

A process to provide products and or services to the correct specification, price, quality , lead-time and quantity by means of a customer focused philosophy in order to satisfy the requirements of the individual and make the product as attractive as possible

Note – market and economic factors, process needs to be flexible, every country has a different marketing philosophy

Customers

End user – operational therapists, distributors, agents

Actors

All employees, distributors, agents

Transformation

Raw materials – finished product

Order received – order fulfilled

Customer enquiry – order being places

Customer comment - to satisfactory outcome

Need identified – product developed

Worldviews

1. Different countries, different priorities, different perceptions, - flexibility
2. Customer focused
3. Owners baby
4. Meaningful employment
5. Employees view – doing a lot of good
6. Different views of therapies
7. Timber versus metal – design and taste

Owner

MD

Environment

Legal requirements, the market, economics, possible barriers to free trade, views on therapy, EEC legislation

Activities	Inputs	Outputs	Mechanisms	Issues
Develop product <ul style="list-style-type: none"> ◆ Identify need ◆ Develop concept ◆ Build prototype ◆ Trial prototype ◆ Produce full specification ◆ Launch product 	Need/ requirement Resources (Finance, Creativity, knowledge)	New design Prototype Data and information (Feasibility studies, Risk analysis, cost data) Marketing plan Decision [go or no go]	Facilities for R&D Competencies to do it Trade fair	Finance Costing Customer requirements Agents compensation
Get order <ul style="list-style-type: none"> ◆ Promote product and co ◆ Get appointment ◆ Prepare quote ◆ Send to customer/purchasing authority ◆ Receive order ◆ Enter order in records ◆ Check outcome 	Quote Official order Initial enquiry Request for a quote Marketing plan	Invoice raised Works order produced Response to customer Order acknowledged Delivery date Cost data	Representatives Distributors and agents Internet, telephone, fax, mail IT – sales order processing database Marketing manager	Competition Quality of sales staff Ability to purchase Budgets of customers Technology and information needed Lack of funds Legislation
Fulfil order <ul style="list-style-type: none"> ◆ Check status [current stock and MPS] ◆ Purchase items ◆ Develop MPS & Issue schedule ◆ Make ◆ Pack product & Despatch ◆ Check outcome 	Works order Materials Resources Schedule MPS Order status	Completed order Waste material Data and information Reports Performance measures Cost data	Procedures Processes Machines People Technology Manufacturing database Legislation Suppliers	Resources – being able to achieve it with the people, materials and equipment Regulations and legal req. Rewards and recognition Capability to supply Space – 2 levels
Support customer <ul style="list-style-type: none"> ◆ Identify liability and response ◆ Identify action plan ◆ Implement action plan ◆ Check with customer 	Customer enquiry Knowledge from completed order Works order information	Technical advice Progress reports Decision to proceed Satisfactory outcome	Ability to get sales agents to see the customer Database Ability to deal with customer complaints IT system to support and provide customer info Corrective action guidelines	Personal involvement Finance Debt built up Customer satisfaction Ensure data entered correctly One point of entry

General actions required

Identify applicable software to managers [A33 – 1 to 5]
 Process based teams – machining
 Customer focused teams – assembly and final assembly
 2 skill levels – financial issues – cost activities and cost drivers
 2 aspects – getting things under control and longer term
 Marketing planning – develop product
 Marketing plan – get order

Actions for the operate process

Decompose – identify need

Decompose A12, A13, A14

To include product ??? and design for manufacture

Marketing plan – more detail

Develop fulfil order – A3

A4 – put in A45 – monitor action plan

A34 – make – raw materials – components

Component/assembly to final product

Technology aspects

Make or buy – subcontract???

Issues for implementation

Issues to be resolved

How to measure of people are performing the job

Wages

Expectations

Cultural – internal and Newton Abbott

Environment in factory

De-skilling - depends on the product

Too many products – need

Employing older people

Product analysis and review

Product development

Visibility – costing, material, BoM, production costs, overhead rates

Need basic data

WHO is going to do it

Champion???? – respect, appropriate, can achieve it.

ADDITIONAL COMMENTS.

From: "J Dinwoodie" <CS_FS14/JDINWOODIE>
Organization: University of Plymouth
To: tgreswell
Date sent: Tue, 16 Sep 1997 13:45:10 BST
Subject: SSM Manufacturing strategy manual

Tammy:

thank you for your excellent discussion .. here are a couple of ideas which may help you to question your approach ?

- this excellent, well done.

- what are the criteria for inclusion as a stakeholder [you say an s/h is involved in the formulation process - BUT how is interest defined .. financial / employment / shareholdings / technical knowledge ?]

- On your benefits of involvement - would a financial return (£) help to convince senior staff ? .. have you any examples of same ?

- Is there a 'rich picture' (rather than flowchart) of your approach ?

ALSO - is there a LIST of points / stages in your approach (I find the flowcharts rather restrictive - I want to jump in & out of this iterative PROCESS more - which a simple statement of your steps might help me to do ?

- p8, Sect 2.1 Make more of the perception of the problem situation .. is there a threshold level of anxiety required before action (ie application) of your approach is triggered ?

2.1.1.1 customer complaints, clients, suppliers .. valid stakeholders ?

p18: you impose the criteria.. would a couple of blanks help for users to define ?

2.2.4 Mind maps .. but HOW do they draw them ..

p40 the actor may 'CAUSE TO BE CARRIED OUT' ie external legislators, customers, competitors can all force change .. dont ignore them

Hope this is useful .. this is brilliant & if youre in Plymouth, you would make an excellent guest lecturer to our Masters...

JOhn Dinwoodie, 2446, fax 232406, jdinwoodie (email)

Publications

Greswell T, Childe S J, Maul R S, Bennett J, (1995)
'A Two fold approach to manufacturing improvement',
*Proceedings of the Twelfth Conference of the Irish
Manufacturing Committee,*
6-8th September, University College Cork,
pp. 429-436 (IMC95.ps)

A TWO FOLD APPROACH TO MANUFACTURING IMPROVEMENT

T Greswell, S Childe, R Maull

School of Computing
University of Plymouth
Drake Circus, Plymouth
Devon PL4 8AA

J Bennett

Plymouth Teaching Company Centre
University of Plymouth

ABSTRACT

This reports on a study into the formulation and implementation of improvement initiatives and their link to manufacturing strategy at a major UK manufacturing company.

The study assesses two approaches, namely the strategic formulation path leading to improvement initiatives and the modelling of a process using IDEFo leading to the identification of potential improvements.

The formulation of manufacturing strategy to pinpoint improvement initiatives was achieved by asking two fundamental questions, 'What does the business require from manufacturing?' and 'What does the manufacturing manager require from manufacturing?' The resulting 'one liners' were evaluated using brainstorming and affinity diagrams. The analysis allowed the pinpointing of problem causes. The causes were grouped and prioritised using matrix techniques to produce a list to be used as a starting point for improvement initiatives.

The second approach was to prepare an IDEFo model of a manufacturing process. The model was developed using interviews with employees familiar with the process. When completed the model was analysed by multi disciplinary team, identifying specific areas that required attention. The techniques are compared and evaluated and the paper concludes with a number of guidelines to promote greater cohesion between strategy formulation and improvement initiatives.

1 INTRODUCTION

The two fold approach to manufacturing improvement has been introduced to the case company 'A', to determine if the two techniques described are compatible when used concurrently, or if the techniques should be used independently.

The two fold attack consisted of a top down approach which focused on the development of the structure and content of the manufacturing strategy as a method for identifying manufacturing initiatives and a bottom up approach which looked at a process in detail using IDEFo as the modeling tool.

2 THE TOP DOWN APPROACH

The research group and the company opted to use a 'soft systems' approach to the formulation of the manufacturing strategy. The soft systems approach pioneered by Checkland [1] appreciates that problems in human activity systems are difficult to define considering that everyone has their own point of view. To gain an understanding of the problem it must be understood that there is no 'ideal' solution to any one problem which will satisfy everyone's point of view. Soft systems thinking encourages and allows radical "out of the box thinking". The methods are designed for user participation which leads the group to a consensus decision.

The techniques used in the case company were developed as the 7 Management and Planning tools. These tools originated from the Japanese Society for Quality Circle Technique Development and have been summarized by Brassard [2]. The formulation of the manufacturing strategy was initiated with the asking of the fundamental questions '*What does the business require of manufacturing to remain competitive?*' and '*What does manufacturing require of the business to be able to be competitive?*' The questions provided the management team with the requirements of the business which needed to be considered to be competitive. The top 5 requirements were used as a basis for brainstorming the issues involved in those requirements. The requirements included,

- No cost surprises
- No post delivery failures
- Minimum response time
- 100% dispatch reliability
- Product which meets the customer specification

Ground rules were established to allow the brainstorming session to generate ideas at a freewheeling approach to idea generation as opposed to the logical intellectual level. This approach aims to generate as many ideas as possible. The ground rules covered: no criticism of ideas, freewheeling, large quantity of ideas required and ideas recorded exactly as spoken.

The ideas were recorded on post-it notes and on a flip chart, with one idea per post it. Following the brainstorming, the cards were grouped using the affinity diagram technique [2]. The technique allows the gathering of large amounts of information including ideas, opinions issues etc. The information is then grouped depending on the natural relationship between each item. The cards were spread out randomly on a table. The team were requested to relate the cards in some way into approximately 8 groups. This was done in silence to ensure total concentration. The team were instructed to move cards if they didn't agree with its position within a certain group. The next stage in the process was the creation of header cards, to capture the central idea of the group. The final stage of the process was to relate groups near each other and to draw lines round each grouping. This process is shown in Fig.1.

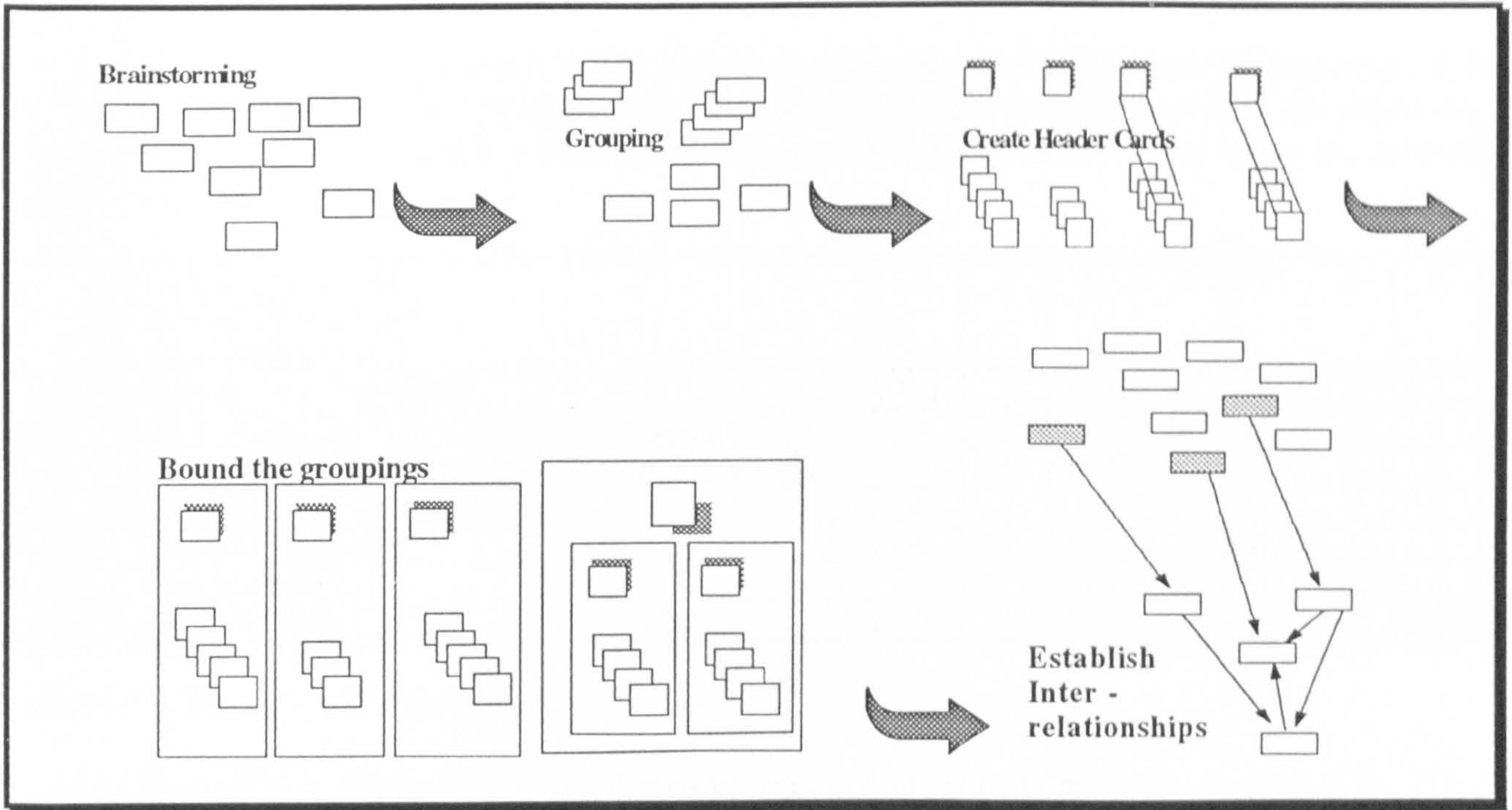

Fig.1. The Affinity Diagram Process

The next stage was to establish the interrelationships between the cards, the header cards were removed and the cards were analysed one by one asking - ‘does any other card cause this issue or result from this issue?’ Arrows are drawn in the appropriate direction. This is repeated for every card. Refer to Fig.1. The key items were chosen from the card with the greatest proliferation of arrows. The technique is visual and descriptive. Due to the proliferation of issues - 300 in total, the method was adapted to use the cause and effect matrix. The key items were transferred to a Cause and Effect matrix to rationalise the issues into a manageable group, an example is shown at Fig.2. The identified causes were then transferred to a prioritisation matrix at Fig.3..

Issue	A	B	C	D	E	F	G	Causes
A Inadequate resources / skills		C	E					1
B Lack of disciplined approach attention to detail	E			E				0
C Over complication - products / processes / paperwork	C					E	C	2
D No learning from past mistakes		C				C	C	3
E Lack of accountability								0
F Poor role clarity			C	E				1
G Lack of flexibility			E	E				0

Fig.2. Example of a Cause and Effect matrix

The matrix allows each issue to be described as a cause of another issue or an effect of another issue. In this way the issues which are deemed to have the highest cause factor - such as D - “No learning from past mistakes”, should be a high priority. The causes are summed to indicate highest priorities.

The use of the prioritisation matrix helped to rationalise the 300 issues to 30 key areas. Refer to Fig.3. These issues were presented to the manufacturing team leaders, who took the issues back to their teams to decide which ones they felt they could begin to tackle. The teams are currently addressing each issue.

	1 = More Important 0 = Equally important -1 = Less important	A	B	C	D	E	F	G	Total
A	Inadequate resources/skills		0	1	0	0	1	1	3
B	Lack of disciplined approach attention to detail	0		0	-1	-1	-1	1	-2
C	Over complication - products / processes / paperwork	-1	0		0	-1	0	0	0
D	No learning from past mistakes	0	1	0		0	1	1	3
E	Lack of accountability	0	1	1	0		0	1	3
F	Poor role clarity	-1	1	0	-1	0		1	0
G	Lack of flexibility	-1	-1	0	-1	-1	-1		-5

Fig.3. Example of the Priority Matrix

Examples of some of the issues developed into initiatives include:

- Blame culture, low morale, must be seen to be doing something, eliminate fear and stress
- Lack of understanding of plans and planning tools
- Task focused - achieve at any cost
- No incentive to put right what has gone wrong
- Poor definition/understanding of plans/planning tools
- Lack of communication,
- Lack of commitment to promises plans
- Design not adequately finished proven
- No learning from past mistakes
- Incorrect constitution of planning teams
- Lack of shared objectives/understanding of roles

3 THE 'BOTTOM UP' APPROACH

The bottom up approach took the 'hard system' route. In hard systems thinking the analysis is systematic, well ordered with specific rational steps. In this way the present state is defined using a specific modeling tool or technique, the desired state is defined in the same way with alternative approaches to achieve the desired state available.

The team decided to use IDEFo, the ICAM definition method [3] to model the Printed Circuit Board (PCB) manufacturing process to enable a systematic and detailed approach to defining key areas for improvement.

See Fig.4. The technique uses one box for all activities, with the configuration as above. IDEFo asks the business:

- What activities are required to carry out the business?
- What inputs are transformed into what outputs?
- What influences / controls / triggers / regulates / constrains these activities?
- What means are needed to perform these activities?

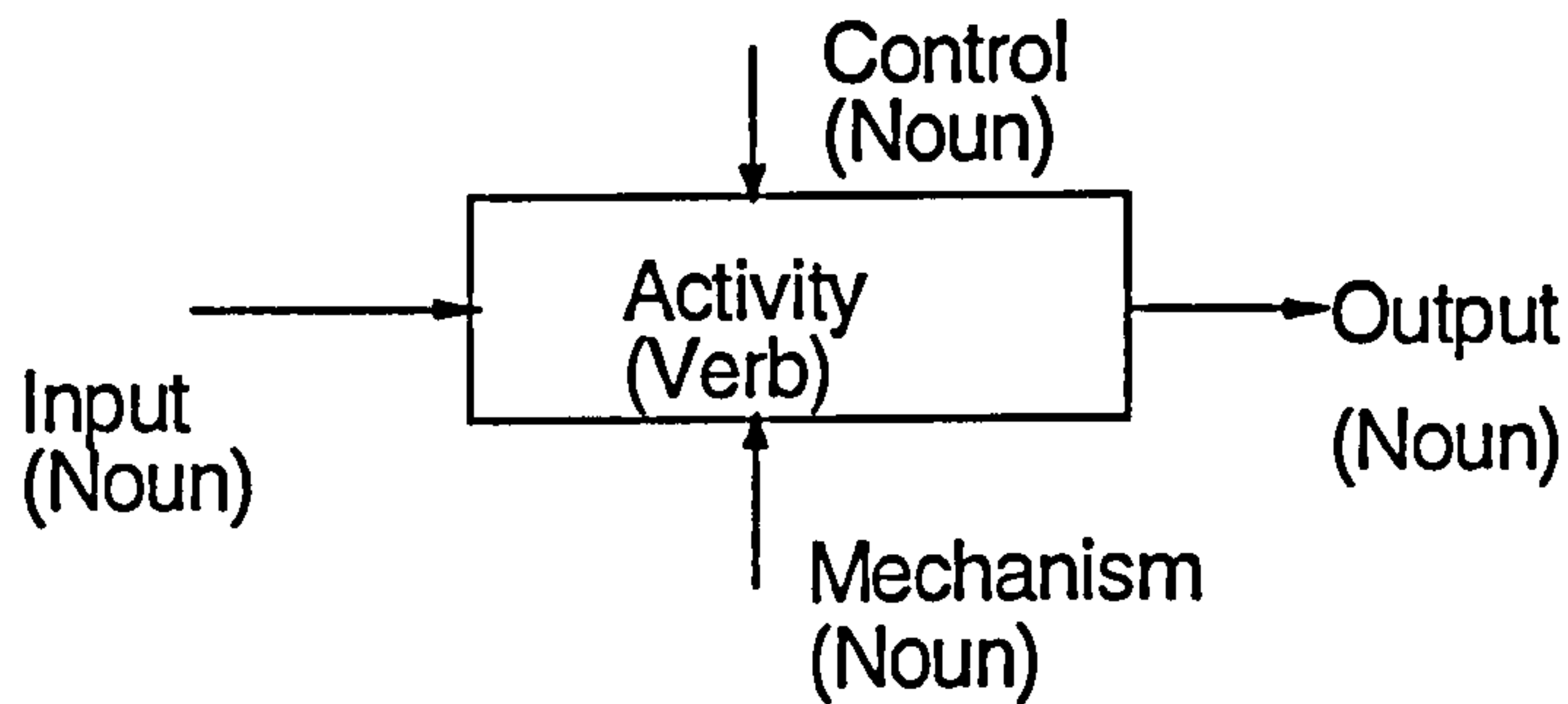

Fig.4. IDEF Box

The rules if IDEFo are very simple

- every box must have a control
- allow one diagram to a page with 3 to 6 boxes
- activities must be described with imperative verbs
- all arrows must be labeled
- arrows may join or split
- arrows may be combined at higher levels and decomposed at lower levels. See Fig.5.

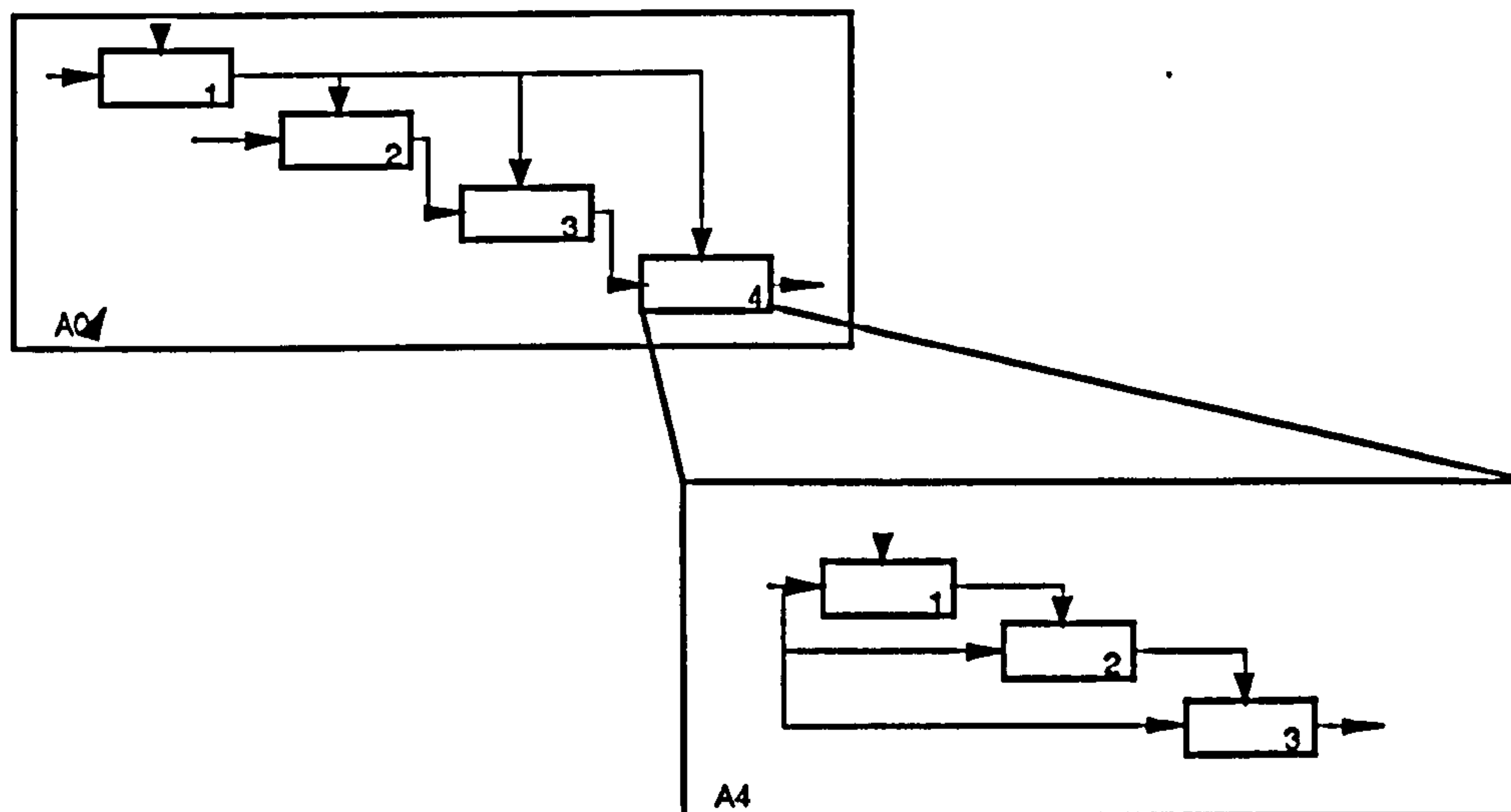

Fig.5. Decomposition

The beauty of the technique lies in the hierarchical nature of the modelling. The process to be modelled can be shown at the top level, i.e. important for senior managers to understand the fundamental inputs outputs constraints and mechanisms of the business, and can also be decomposed into greater detail for analysis at the working level of the business.

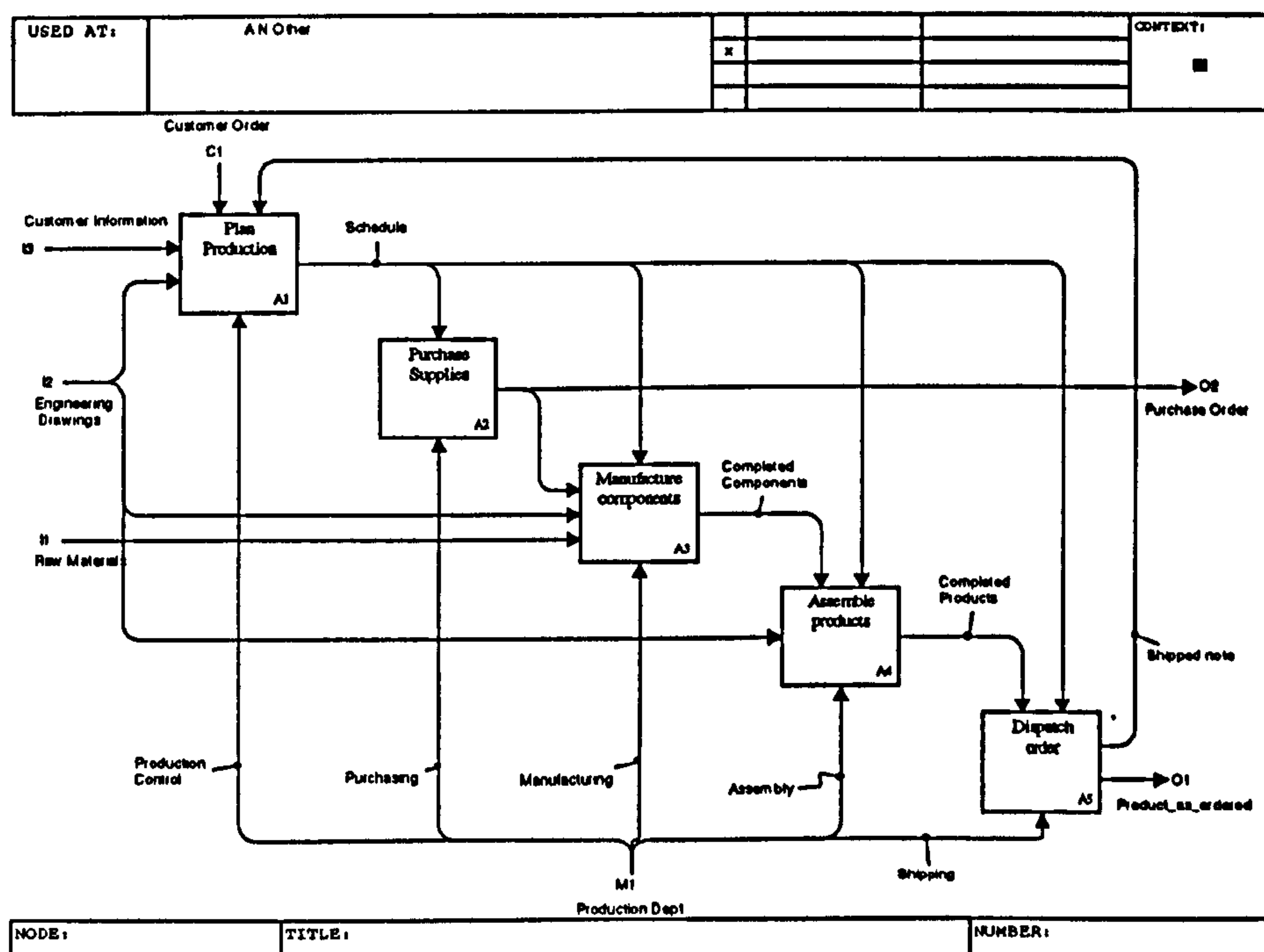

Fig.6. Example of IDEF0

The IDEF0 model for the manufacturing process was developed using structured interviews with the staff associated with the process. An example is shown at Fig.6.. The detailed models were analysed by a concurrent team including both university and company associates to identify key opportunities for improvement and radical change opportunities.

Evaluation of the model was carried out by asking the following questions of each decomposition.

1. What is value added?
2. What activities can be joined?
3. What activities can be discarded?
4. What activities can be done in parallel?

Each diagram identified a variety of issues which were discussed and noted for further development. The process was extremely useful for the company staff as it asked them to look fundamentally at their process and determine what was value added and what was not. The analysis took a great deal of effort both in time and human resource.

The analysis of the models was further enhanced by providing the associates with a common graphic language which was simple to use. The issues which arose from the discussion were minuted to ensure a record was kept. At the time of writing the process of developing initiatives is still ongoing. The models have been presented to the manufacturing team leaders to encourage 'buy in' to the activity.

4 EVALUATION OF THE TWO APPROACHES

Attributes	7 Management Planning Tools	IDEFo - modelling the process
Systematic	√	√
User friendly	√	√
Requires facilitation	√	√
Consensus	x	√
Initiatives	√	√
Training required	x	√
Software required	x	Perhaps

The process using the 7 Management and Planning tools worked well, with a wide range of staff from different backgrounds. The ideas generated have provided the manufacturing teams with 30 issues to tackle. The "gut" feel approach provided the issues which were obviously important to the participants. This in turn provided the boost of motivation and enthusiasm to develop solutions to the problems generated. The process enables the use of creativity in a structured manner providing a channel for "out of the box" thinking. The opportunities for improvement contain several complex issues which may require greater senior management commitment. The process followed appeared to be very effective for unleashing powerful ideas from the staff. The actual time scale of the process was quite short, a time span of 2 months. However the implementation of the initiatives will be continual.

The IDEFo method was used by a smaller dedicated team as a pilot study. This was to determine if the use of IDEFo was useful in identifying opportunities for improvement. The physical modelling of the process in itself proved to be a effective way of learning about the organisation and raising awareness of the intricacies of the process through interviewing staff. The tool provided a common language which enabled all staff associated with the process to understand what happened, where and why. Following the completion of the 'As is' model, the analysis of the model was carried out, again by the same dedicated team. This process proved extremely useful for identifying opportunities for improvement. The model allowed the identification of duplication, excessive checking, data disappearing down black holes, and non value added activities. The process identified ACTUAL problems which could be re-engineered.

The two approaches have been equally successful in evolving initiatives from the conception of an idea to a solid basis for improvement. The soft systems method involved gut feelings allowing the participants to be creative in a structured method - a tall order. The IDEFo method allowed the process to be analysed in detail, showing the non value added activities, mechanisms, controls, departments and people involved in the process. The method picked up on duplication of effort, continuous checking of checking all wasteful activities. Both methods have worked well in the company to generate the ideas and motivation for the initiatives. The next step of implementing radical or incremental change will be crucial.

Space does not permit further discussion of these experiences. The following guidelines presented in section 5 have been developed from the work carried out.

5 GUIDELINES FOR GREATER COHESION BETWEEN MANUFACTURING STRATEGY AND IMPROVEMENT

- Gain top management commitment in both time and resources. A senior manager as a champion for the process is vital to succeed.
- Assess the strategic position of the company.
- Determine certain specific objectives bound to the corporate strategy i.e. what does the business require of manufacturing, and what does manufacturing require?
- Determine the requirements and the capability of the business to reach the specific objectives.
- Take the critical requirements [the number will vary considering the business] e.g. 'Product which meets customers specification' and using the 7 Management and Planning tool techniques described, determine the root issues and subsequent causes for each requirement.
- Categorize the causes using classifications such as people, product, parts and processes to rationalise into manageable groups
- Use the Cause and Effect matrix to rationalise the identified root causes i.e. what is a cause and what is an effect
- Use a priority matrix to prioritize issues.
- Present top issues as Opportunities for Improvement
- Set up project teams to look at OFIs
- Model processes
- Analyze processes using a dedicated team
- Compare issues, rationalize if possible
- Implement radical or incremental change

6 CONCLUSION

The two methods used for the generation of initiatives for manufacturing improvement were equally beneficial in several ways, a large number and variety of staff became involved in the process, which proved to be useful in both the creative and systematic methods of generating initiatives. The methods generated a great deal of enthusiasm and momentum to carry the initiatives to their conclusion. The progress of the initiatives will be published when appropriate.

7 REFERENCES

1. Checkland P, *Systems Thinking, Systems Practice*, Wiley, New York 1981
2. Brassard M, *The Memory Jogger Plus+ Featuring the Seven Management and Planning Tools*, Goal/QPC, Methuen, MA, 1989
3. Le Clair S, *IDEF The method, architecture the means to improved manufacturing productivity*, SME technical papers, Society of Manufacturing Engineers 1982

Greswell T, Childe S J, Maul R S, Bennett J, (1995)
'Linking Manufacturing Strategy to process improvement',
*Advances in Manufacturing Technology IX, Proceedings of
the 11th National Conference on Manufacturing Research*
12-14 September, De Montfort University Leicester, pp 656-
60 (NCMR95.ps)

THE LINKING OF MANUFACTURING STRATEGY TO BUSINESS PROCESS RE-ENGINEERING

Tammi Greswell, Roger Maull, Steve Childe
University of Plymouth, UK

Jan Bennett
Plymouth Teaching Company Centre, UK

ABSTRACT

The following paper presents several ideas concerning the effects of organisations moving towards a process focus rather than a functional focus. The effects of these ideas on the domain of manufacturing strategy will be discussed and presented with experiences from three manufacturing organisations currently engaged or planning Business Process Re-engineering programmes. The paper concludes with a discussion pulling together the issues to be considered when implementing process based change and the effects on manufacturing strategy.

INTRODUCTION

Manufacturing Strategy is a powerful concept that has been identified by a variety of authors such as Skinner (1969), Hill (1985) and others, which enables manufacturing organisations to align their processes with appropriate markets. It is generally accepted that manufacturing organisations should align their manufacturing processes and infrastructure to support the corporate and business strategies. The content of manufacturing strategy has been well researched but there appears to be a gap with the development of methodologies for the process of formulating manufacturing strategies.

Recently, the issues surrounding manufacturing strategy have become more complex. Organisations are not only looking at market led strategies, but are looking inwards to determine how to increase their competitive edge by looking at the internal competences within the firm [Hamel and Prahalad 1995].

Organisations are moving towards flexibility, innovation and processes and there appears to be a need to reassess the current models concerning manufacturing strategy to determine how the current models can be best utilised and modified for different organisations. Treacey and Wiersema (1995) model of strategy suggest that organisations must choose between focusing on product leadership, customer intimacy or operational excellence. The focus of the goals and objectives in these organisations should be based around the concept chosen.

The redefinition of manufacturing strategy may be necessary to enable organisations to be able to cope with the changing manufacturing environment i.e. process focused organisations and the move from market led strategies to competence led strategies.

MANUFACTURING STRATEGY IN A PROCESS FOCUSED ORGANISATION

Manufacturing Strategy has been described as a dynamic process consisting of a pattern of decisions involving key areas within the manufacturing function. How will this definition change in organisations which are becoming process focused with a blurring of functions. The issues surrounding this question will vary in complexity depending on different industries, their position in the supply chains, and their type of manufacturing i.e. engineer-to-order, assembly-to-order or make-to-order and make-to-stock organisation. The current research is bounded within the aerospace industry to allow certain assumptions to be made and to reduce the complexity of the issues above.

The development of strategy within an organisation tends to be hierarchical in nature. The development of business processes within organisations have followed this trend and also exist in a hierarchy. This may be due to the dominance of systems thinking in the analysis of any human activity system can be presented as a hierarchy.

The first question is how to define a business process? It is important at the outset to bound the phenomena that is being studied. The definition of a business process is ' "simply a structured, measured set of activities designed to produce a specified output for a particular customer or market". Davenport (1993). Weaver et al (1995) has developed a process hierarchy based on Jorysz and Vernadat (1990) which divides business processes into manage, operate and support processes, see table 1.

Table 1 Core Business Processes

Manage Processes	Operate Processes	Support Processes
Set Direction	Get Order	Manage Finance
Plan Strategies	Develop Product	Support Personnel
Direct Business	Fulfil Order	Manage Technology
	Support Product	Corporate Learning

The management processes are bounded by being predominately creative and dynamic. The operate processes are based on the day to day operations as bounded by the operating strategy. The support processes relate to management of resources.

To relate the work done surrounding manufacturing strategy to a business process focus [Business Process Re-engineering] it may be useful to compare the classic decision areas of manufacturing strategy as defined by Hayes and Wheelwright (1984) with the core business processes which will be affected by those decisions. Table two presents a conceptual framework to be used for discussion in determining how and where manufacturing strategy

may need to be modified when applying current manufacturing strategy models to a process focused organisation.

The model is still in the early phases of development and will be tested within several manufacturing organisations. The model will be developed further from the testing phase of the research.

Table 2

<i>Capacity</i>	<ul style="list-style-type: none"> • Product plans, resource - people and equipment, flexibility, similarity of products, planning accuracy • All core processes
<i>Facilities</i>	<ul style="list-style-type: none"> • Number, location and focus. Multi site? Single plant? Product line? • All core processes
<i>Process technologies</i>	<ul style="list-style-type: none"> • Requirements of product technologies and markets. Technological availability and risk implications. • Set direction • Plan strategies • Direct business • Get order • Develop product
<i>Vertical Integration</i>	<ul style="list-style-type: none"> • Direction and extent of product span • Plan Strategies • All operate processes
<i>Human resources</i>	<ul style="list-style-type: none"> • Definition of job structure. Technical competences, problem solving capabilities, use of teams. Integrating the human-machine interface • All core processes
<i>Quality Policy</i>	<ul style="list-style-type: none"> • Fitness of process and product for purpose • All core processes
<i>Production planning / materials control</i>	<ul style="list-style-type: none"> • Project and financial control systems to suit the organisational structure • All core processes
<i>New product development</i>	<ul style="list-style-type: none"> • Selection, cultivation and development of new products • Get Order • Develop product • All core support processes • Plan strategies
<i>Organisation</i>	<ul style="list-style-type: none"> • Organisation structure to suit the product and market requirements and altering it as the requirements change • All core processes
<i>Performance measurement and reward</i>	<ul style="list-style-type: none"> • Development and operations of systems to generate data about functional performance against financial and non financial parameters • All core processes
<i>Customer focus</i>	<ul style="list-style-type: none"> • Future and current needs of the customer - are these addressed? • All core processes

The decision areas will all have some impact on the core processes identified. If, as has been suggested by several industrial interviewees the functions become redundant - would it be more appropriate to develop strategies along process lines rather than across functions.

In the authors opinion the hierarchical nature of strategy formulation and the hierarchical nature of processes are well suited to this change to a process strategy.

The changes from a manufacturing strategy to an 'order fulfilment' strategy would incorporate a holistic view of the entire process and enable the process owners, operators and leaders to be fully involved in both the day to day operation of the process, but also strategic decisions which will have larger impacts in the areas of work. These ideas still need to be tested and validated to determine if they are useful in the areas of operations and manufacturing strategy.

BUSINESS PROCESS RE-ENGINEERING AND MANUFACTURING STRATEGY

A significant of research has been accumulated over the past couple of years within the domain of business process re-engineering (BPR). The most important aspect in the authors view is that of the concept of the business process focus. This incorporates taking a systemic view of the organisation as opposed to a reductionist systematic view.

Business processes and manufacturing strategy are closely linked in several ways - they are both enablers of change programmes, and both exist in an hierarchy. It appears to be relevant at a time when a large number of organisations are becoming interested in business process re-engineering to develop links between the two domains of research. Strategy formulation is in itself a core business process, if the two areas can be brought together and formed into a cohesive methodology, the benefits from both areas could be merged and enhanced.

A business process can be expressed in terms of a human activity system, whereas a manufacturing strategy would be expressed as a designed abstract system - which exists but is not tangible. Systems thinking can therefore be applied to both concepts and the linking of BPR and manufacturing strategy is best described as a conceptual soft system - i.e. there are numerous viewpoints that must be expressed, the problem situation is 'messy' and there is no optimum solution.

It may be appropriate to redefine manufacturing strategy and realign the concepts and well developed models and tools to be able to assist in redefining strategy for the newly defined core processes.

ISSUES CONCERNING BPR AND MANUFACTURING STRATEGY ARISING FROM EXPERIENCES IN THREE MANUFACTURING ORGANISATIONS

To further develop the ideas expressed above, 3 case studies were used to gather data concerning business process re-engineering programmes and their approaches to manufacturing strategy. The cases were taken from engineer-to-order organisations with multiple customers including aerospace to ensure comparisons and issues could be extrapolated from the research.

All cases had some form of manufacturing strategy, all were articulated but no formal planning process specifically for the manufacturing strategy were identified. The models and techniques developed for the formulation process within academia were used as references, but were not followed diligently and in a couple of cases not at all. One of the cases were planning to follow both a market focused route and a competence based approach to developing their manufacturing strategy. One of the case companies was in the middle of a major BPR programme and benefits were beginning to become evident within the organisation. The linkages to the manufacturing strategy and BPR came mainly from the stretch goals identified and the determination to move towards the 'lean manufacturing' model.

The major enablers identified from the cases, to changing from a functional to a process focus appear to be the use of Information Technology and the use of concurrent engineering teams.

The Information Technology strategy adopted by one of the cases will have a significant impact on the manufacturing lead times, the manufacturing information environment and will change the working practises within the organisation.

The other major enabler is the movement to concurrent engineering teams. In another of the cases three core operations processes were identified. These being product development, order processing and customer support. The concurrent engineering teams make up will change according to the development of any particular project, this will be managed from an organisational structure based around process owners, resource owners and product owners. It is envisaged that the individual product owners will 'buy' their resource from the appropriate process and resource owner. The softer issues of leadership, team working, and multi skilling will all need to be addressed. How multi skilled should team members be in a multi skilled team?

Other issues which have emerged from the three cases is how to develop the internal competences required for each process. Whether each process owner will develop, hire, create career development plans for their individual process or whether this will be done from a central base will need to be addressed.

From the cases, it is envisaged that the process owners would be responsible for determining the process order winners and process order qualifiers that are required by the market, probably developed from the corporate and business plans. A two way link can be envisaged with the development of the competence based strategies determining the overall business and corporate strategy.

The following questions may be useful in determining the linkages between business processes and manufacturing strategy.

Does the process capability allow for the development of process strategy based and growth in new undiscovered markets?

Does the process capability meet the needs of the current market?

- Inside out competence based process strategy.
- Outside-in market led approach to strategy

CONCLUSION

The change from a functional organisation to a process focused organisation have raised several issues which will need to be addressed in the realignment of manufacturing strategy towards a process focus and a competence based view of the organisation.

The movement of organisations towards a process focus has given the domain of operation and manufacturing strategy an exciting opportunity to further develop the models and techniques available to incorporate these issues. Many of the issues identified could be addressed within the manufacturing strategy formulation process with further development. Further research will seek to address these issues and incorporate all the work already done surrounding manufacturing strategy into the new paradigm.

REFERENCES

- Davenport T *Process innovation : Re-engineering work through information technology* Harvard Business School Press
- Hayes R and Wheelwright S *Restoring our competitive edge - Competing through manufacturing* John Wiley New York NY 1984
- Hill T *Manufacturing Strategy: The strategic management of the manufacturing function* MacMillan 1985
- Jorysz H R and Vernadat F B "CIM-OSA Part 1: Total enterprise modelling and function view", *International Journal of Computer Integrated Manufacturing* Vol. 3 No 3 1990
- Skinner W "Manufacturing - missing link in corporate strategy" *Harvard Business Review* May-June 1969
- Treacey M and Wiersema F *The discipline of market leaders - choose your customers narrow your focus, dominate your market* Harper Collins 1995
- Weaver et al 'Core Processes Framework ???????????????'

Greswell T, Childe S J, Maul R S, Bennett J, Campbell N
(1995)

The role of manufacturing strategy within a Business
Process Re-engineering change programme,
*Proceedings of the 13th International Conference on
Production Research*, Jerusalem, Israel August 6-10
pp 144-146 (ICPR95.ps)

THE ROLE OF MANUFACTURING STRATEGY WITHIN A BUSINESS PROCESS RE-ENGINEERING CHANGE PROGRAMME

T J Greswell, R S Maull, S J Childe, J Bennett

School of Computing, University of Plymouth, Drake Circus, Plymouth, PL4 8AA,
UK Fax 01752 232540

Abstract

This paper outlines a study into the role of Manufacturing Strategy within a Business Process Re-engineering (BPR) change programme in a major UK manufacturing company. The approach to strategy formulation within the company and the relationship the strategy has with the change programme is described. The paper concludes with a number of guidelines for linking the role of manufacturing strategy within a BPR change programme.

Introduction

The company has taken a 2 stage approach to manufacturing strategy. The first being a top down approach which encompasses the structure and content of the manufacturing strategy. This was developed by a team from Manufacturing Systems to enable generation and prioritisation of change initiatives. The second being a bottom up approach, which entailed the modelling of processes as a means of identifying key problem areas and proposing change initiatives.

The Top Down Approach

The approach for formulating the manufacturing strategy consisted of asking key questions of the stakeholders concerned, i.e. what does the business require of manufacturing and what does manufacturing require of the business, to be able to meet their demands. The following programme was developed to ensure compatibility between the strategy and the change programme. The techniques used below were taken from *The Memory Jogger Plus + Featuring the Seven Management Tools*¹ and included affinity diagrams and interrelationship digraphs.

- Affinity diagrams are used to gather large amounts of data including ideas, opinions, and issues. These are organised into groups based on natural relationships between each item.
 - Interrelationship digraphs which take complex and often multi faceted problems and explores and displays all the interrelated factors involved, graphically showing the logical and casual relationships
1. Review existing top level primary and secondary requirements of Manufacturing Strategy
 2. Brainstorm issues surrounding 'Top 5 Business Requirements'
 3. Rationalise issues by categorisation using People Parts Process and Plan
 4. Complete cause and effect matrix

5. Transfer identified causes to prioritisation matrix
6. Identify and Prioritise initiatives to address prioritised issues
7. Form teams and implement

A review of the process is presented in a paper entitled 'linking manufacturing strategy to process improvement' ⁴

The Opportunities For Improvement [OFI] taken up by improvement teams included some of these issues: a blame culture leading to low morale caused by fear and stress, a lack of understanding of plans and planning tools, no incentive to put right what has gone wrong and a lack of communication,

The Bottom Up Approach

This approach provided a detailed and systematic approach to defining key areas for improvement within a particular process. The Printed Circuit Board Manufacturing process was modelled using IDEFo ⁷, the ICAM Definition method which is used extensively in the manufacturing sector for this purpose.

The IDEFo models were scrutinised using a multi functional team facilitated by the University, to identify key opportunities for improvement. The strength of the models was that it provided the basis for heated discussions and debates surrounding major issues and opportunities for improvement

The evaluation of the model were carried out in a formalised manner. For each activity the following questions were asked

1. What is value added?
2. What activities can be joined?
3. What activities can be discarded?
4. What activities can be done in parallel?

For each diagram various issues were discussed and ideas noted as issues and questions as a basis for further work. This allowed a list of 'real' issues to be drawn up for further discussion as the basis for real opportunities for improvement

Guidelines

The linking of manufacturing strategy to BPR will become increasingly important as more companies take on change programmes. The importance and necessity of linking change and improvements to the strategic positioning of the company can not overlooked.

The following guidelines have been formulated using the experience of the above company and other sources. ^{2,5,6}

1. Gain top management commitment in both time and resources.
2. Evaluate the strategic position of the company.
3. Define specific objectives linked to the corporate strategy.
4. Determine the requirements of the business to reach the above objectives.
5. Take the top 5 requirements and determine the root causes.
6. Categorise the root causes, present top 10 issues as Opportunities for Improvement
7. Model processes using IDEFO
8. Analyse processes using the above techniques
9. Compare issues and implement improvements

References

1. Brassard M, *The Memory Jogger Plus+ Featuring the Seven Management and Planning Tools*, Goal/QPC, Methuen, MA, 1989
2. DTI Competitive Manufacturing : A practical approach to the development of a manufacturing strategy. *IFS Publication*
3. Hayes Pisano Beyond World Class The new manufacturing strategy *Harvard Business Review January-February 1994*
4. Greswell T, Maull R, Childe S, Bennett J Linking manufacturing strategy to process Improvements *to be published.*
5. Maruchek A, Pannesi R, Anderson C An exploratory study of the manufacturing strategy process in practice *Journal of Operations Management V9 N1 January 1990*
6. Skinner W Manufacturing - the missing link in corporate strategy *Harvard Business Review May -June 1969*
7. Le Clair S, *IDEF The method, architecture the means to improved manufacturing productivity*, SME technical papers, Society of Manufacturing Engineers 1982

Greswell T, Childe S J, Maul R S, Bennett J, (1996)
'The linking of Manufacturing Strategy to Business Process
Re-engineering'
Euroma Conference Proceedings
June 1996 London

THE LINKING OF MANUFACTURING STRATEGY TO BUSINESS PROCESS RE-ENGINEERING

Tammi Greswell, Roger Maull, Steve Childe
University of Plymouth, UK

Jan Bennett
Plymouth Teaching Company Centre, UK

ABSTRACT

Many organisations are adopting a process focus. Traditional Manufacturing Strategy approaches assume a functional structure. The change of focus from functional organisations to processes may have a significant effect on the way organisations should approach strategy in the future. The effects of these ideas on the domain of Manufacturing Strategy are discussed and presented along with experiences from three manufacturing organisations currently engaged upon or planning Business Process Re-engineering programmes. The paper concludes with a discussion summarising the strategy issues to be considered when implementing process based change.

INTRODUCTION

The following paper presents the author's view of the current state of manufacturing strategy and the changes that may be necessary with the move of organisations from a functional focus to a business process focus. The paper is a result of an extensive literature review within the domain of manufacturing strategy and three empirical studies of companies formulating manufacturing strategy within a process focused organisation. The paper ends with a summary of issues which in the author's opinion should be considered when developing manufacturing strategy within a process focused organisation.

MANUFACTURING STRATEGY

Manufacturing Strategy has been identified by a variety of authors such as Skinner (1969), Hayes and Wheelwright (1984) and Hayes and Pisano (1994), as a means to aid the alignment of manufacturing processes and infrastructure to support corporate and business strategies. Manufacturing Strategy has been described as a dynamic process consisting of a pattern of decisions involving key areas within the manufacturing function. Several empirical studies have concluded that organisations with coherent manufacturing strategies perform better in the market place than those without De Meyer (1990). Various models have been developed to describe the evolution of companies who have used the concept of using manufacturing as a competitive tool. Hayes and Wheelwright's four stage model (1984) describes the movement of an organisation from being 'Internally Neutral' where the objective is to minimise the negative impact of the manufacturing function on the business, through to being 'Externally Supportive' where the manufacturing capabilities shape business strategy.

The majority of manufacturing strategy concepts have focused on the market led approach to strategy, for example Hill (1985). This approach identifies the order winning and qualifying

criteria of products. This differentiates between quality, delivery speed, delivery flexibility and price and with appropriate trade-offs, aligns the manufacturing infrastructure and processes accordingly.

The move of organisations towards stage four of Hayes and Wheelwright's model has generated considerable interest in a different approach to strategy formulation. The 'Core Competence' approach to strategy tends to be inward looking. The core competences are used to develop a competitive edge by using 'difficult to replicate' skills and knowledge. This approach has been described as 'integrating Manufacturing Strategy with the notions of core competencies and learning organisations', (Hayes and Pisano 1994).

The interest in developing manufacturing strategy theory in these areas together with the increasing number of organisations taking a business process approach, has given the manufacturing strategy domain an exciting opportunity to expand its horizons.

BUSINESS PROCESS RE-ENGINEERING AND MANUFACTURING STRATEGY

A significant amount of recent research has been carried out within the domain of Business Process Re-engineering (BPR) Maull et al (1995). The most important aspect in the authors view is the concept of the business process focus, which incorporates a systemic view of the organisation as opposed to a reductionist view. With the increasing number of organisations undertaking radical step change and becoming process focused, it may be useful to develop an alternative approach to strategy incorporating this process focus.

The definition of a business process is "a structured, measured set of activities designed to produce a specified output for a particular customer or market" Davenport (1993). Weaver et al (1995) have developed a process hierarchy based on Jorysz and Vernadat (1990) which divides business processes into 'Manage', 'Operate' and 'Support' processes, see Table 1.

Table 1 Core Business Processes

Manage Processes	Operate Processes	Support Processes
Set Direction, Plan Strategies, Direct Business.	Get Order, Develop Product, Fulfil Order, Support Product.	Manage Finance, Support Personnel, Manage Technology, Corporate Learning.

The management processes are predominately creative and dynamic, whilst the operate processes are based on the day to day operations as bounded by the operating strategy (Porter 1985). The support processes relate to management of resources.

The importance of relating process improvements to strategy formulation has been well documented by authors such as Hout and Carter (1995). They have identified the general mismatch between process improvements and company strategy. When this occurs it is necessary to ensure the two are integrated in a way to achieve competitive advantage. It has been suggested by Hout and Carter (1995) that process excellence alone rarely leads to sustainable competitive advantage i.e. an organisation's strategy - 'what it intends to do' is usually disconnected from its current capabilities 'what it is able to do'. Therefore, taking these issues into consideration, it is the authors view that taking a process focused approach to strategy would align strategy and the competences of an organisation.

To relate Manufacturing Strategy to a business process focus it may be useful to compare the current ideas and concepts surrounding Manufacturing Strategy, as defined by numerous authors such as Hayes and Wheelwright (1984) with the concept of an 'Operate' Business Process Strategy.

Table 2 presents a conceptual framework to be used for discussion in determining how and where Manufacturing Strategy may need to be modified when applying current models to a process focused organisation. The framework is still in the early phases of development and will be tested within several manufacturing organisations.

Table 2: Comparison between the Manufacturing [functional] Strategy Market Led Approach and the concept of an 'Operate' Business Process Strategy Approach

	Manufacturing Strategy [Functional]	'Operate' Business Process Strategy
The Focus	Focus on the manufacturing function and activities and the corresponding decision areas.	Focus on the process activities and core competences needed to deliver the corporate and business objectives and their corresponding decision areas.
Hierarchies	Manufacturing Strategy exists in a hierarchy - corporate, business and functional. Manufacturing can appear as the business strategy or as a functional strategy.	Business Processes are divided into manage, operate and support - the operate processes include 'get order, develop product, fulfil order and support customer'.
Evolution of organisation	Hayes and Wheelwright's four stage model. Internally neutral, Externally neutral, Internally supportive, Externally supportive.	Process improvement to Business Re-engineering. Depends on the <i>scope of change</i> from quality improvement teams to business re-engineering
Participation	Tends to be functionally based.	Multi disciplined teams within individual business processes.
Procedure	Tends to be emergent in nature - result of various decisions. Several methodologies developed e.g. Hill, Mills. Mintzberg model of the strategic management process	Not aware of any process based strategy formulation approach.
Role	Provides a process technology edge, supports the companies market needs better than the manufacturing function of its competitors To align manufacturing processes to the market needs using order winning and order qualifying criteria.	To provide a holistic view of the business process, ensuring a competitive edge whether it is the technological or human competence which gives that edge. To align the operate processes to the market needs.

A significant change between taking a business process strategy approach as opposed to a functional strategy approach would lie in the participation of the people developing the strategy. The approach would encompass not only manufacturing and marketing, but design, finance and personnel. It is envisaged that the process owner would be responsible for developing the strategy taking into consideration the various disciplines within their process team, and ensuring that the necessary competences and technologies are developed in line with the corporate and business strategy.

The decision areas in both approaches would be similar with several additions within the process focused approach. These differences may include, defining the process boundary, the make up of the process team [i.e. the skill set], and the core competences of the process. The strategy formulation tools would again be similar with the addition of business process re-engineering and soft systems methods, (Checkland & Scholes 1991).

The above comparison introduces some ideas which are still in their development phase, and suggests that it may be inappropriate to view manufacturing/operations strategy in the functional paradigm if that organisation has moved to a process/project focus and reorganised around core business processes.

Support for this view has emerged from several case studies which the author has researched, of engineer-to-order organisations within the aerospace industry. The models and methods currently developed for manufacturing and operations strategy are still valid and useful. The author is suggesting that certain aspects and priorities in the decision areas and the development of the strategy may need to be cultivated to allow the process focused organisations to develop further.

CASE STUDIES - BPR AND MANUFACTURING STRATEGY EXPERIENCES

RESEARCH METHOD

In the early stages of the research project, the research team set out to gather empirical evidence from three companies concerning BPR and Manufacturing Strategy. The cases were all taken from aerospace organisations to enable comparison of issues.

The research was structured around two distinct areas - the process of Manufacturing Strategy formulation and current process based change programmes. The issues explored within the process of manufacturing strategy formulation used the key concepts identified by Mills et al (1994). These included point of entry, procedure, project management and participation. The issues explored within process based change encompassed a study of the methods and techniques which have acted as key enablers for achieving a process focus. The difficulties encountered were also covered.

The research methodology developed consisted of both action research and direct observation. The benefits of action research have been well documented by a variety of authors such as Platts (1993). Platts has also reiterated that 'companies have a real need to find improved processes for developing manufacturing strategies'. Action research was used to suggest conceptual frameworks on the tasks of formulating Manufacturing Strategy and interpreted the sequence of events within these frameworks.

The framework used for the analysis of the three cases has been developed from Hayes and Wheelwright's four stage model, in an attempt to position organisations in their journey towards a process focus. The framework will be used to consider how their actions and decisions reflect current Manufacturing Strategy thinking. The objective of the study is to define issues which need to be addressed within process focused organisations that cannot be addressed with a traditional 'functional' approach to strategy.

MANUFACTURING STRATEGY WITHIN THE CASE COMPANIES

The companies are engineer-to-order organisations within the aerospace sector. Case A is a prime contractor and Cases B and C are systems suppliers. The Manufacturing Strategy Parameters identified above were compared in the three cases. The point of entry is defined as the 'event' that triggered the viewpoint of manufacturing as a competitive tool. In all 3 cases the interviewees accepted and had identified the need to use their manufacturing competences to

support the corporate and business strategy. Case C had a problem of filtering the need for a coherent manufacturing strategy upwards within the organisation, however progress has been made and the importance of a manufacturing strategy is becoming accepted. The point of entry for case A and C was described as the 'peace dividend' and the ending of the cold war. Defence budgets necessitated a need to change from a cost plus environment to a fixed price stance. These moves modified the order winning criteria from quality at any cost to one of affordability.

The participation parameter is used to describe which functions and personnel are involved in the formulation of the manufacturing strategy. Case A and B described the participation as being part of operations, which included the input of the manufacturing director, site directors, logistics director and manufacturing strategy executive for case A and the production strategy executive for case B. Case C was unique in the fact that the remit given to the team who were tasked with developing the strategy were to focus on manufacturing alone.

The issues surrounding the actual manufacturing strategy formulation process are difficult to uncover as managers invariably say they are doing one thing and are doing something completely different. The empirical study provided evidence of both a rational approach to strategy i.e. setting goals in which the organisation's capability is matched to the requirements of its environment and an emergent approach to strategy formulation i.e. intuitive rather than analytical. It is the authors belief that the actual process is typically emergent in nature bounded by a rational framework in which to filter the emergent strategy through out the organisation. All cases had regular meetings to discuss strategic choices and their impact on the manufacturing process.

Hayes and Wheelwright's four stage model was thought to be useful in identifying various attributes that manufacturing companies have and may need in order to move from stage 1 to stage 4 of the model, i.e. from internally neutral where the organisation seeks to reduce the negative impact manufacturing has on the competitiveness to the business, to externally supportive where the manufacturing capabilities of the organisation shape the business strategy. Case A and B positioned themselves between stage 2 and 3, which implies the organisation is moving from a benchmarking phase [externally neutral - stage 2 where the objective is to obtain parity with competitors usually following industry] to a world class manufacturing phase [internally supportive - stage 3 where the manufacturing organisation exists to support business strategy]. Case C described itself as being between stage 1 and stage 2.

Table 3 Summary of manufacturing strategy parameters

Parameters	Case A	Case B	Case C
Point of entry event	Peace dividend: cost plus to fixed price contracts	Change in market and technology	Peace dividend: cost plus to fixed price contracts
Participation	Operations: manufacturing director, site directors, logistics director, manufacturing strategy exec.	Operations: production strategy exec	Manufacturing manufacturing director and manufacturing team leaders
Procedure: process of manufacturing strategy formulation	Emergent: i.e. a process of discovery, choice and action	Emergent: ditto	Emergent: ditto
H & W's four stage model	2-3	2-3	1-2

PROCESS FOCUSED CHANGE WITHIN THE CASE COMPANIES

The change programmes from the empirical studies appear to be a result of reaching the point of entry as described above within the manufacturing strategy parameters. Case A are well into a change programme having identified three core operations processes, and reorganising accordingly. Case B has identified four core processes and are currently focusing efforts on them. Case C have identified a process focus as a potential solution, however they are also looking into other configurations such as focused factories.

The interviewees within the three cases were asked what they considered to be the key enablers which had helped them achieve a process focus. The major enablers were cited as being the use of information technology allowing the integration of typically functional specialisms and demystifying certain activities within the core processes. The use of concurrent engineering teams were seen as both an enabler of the process focus but also a 'Pandora's box' of new problems. For example as how multi skilled should a multi skilled worker be in a multi skilled team, career progression within the teams, the changeover of team leaders at different stages of a product life cycle, remuneration etc.

The major problems identified by the interviewees included a difficulty in breaking down the barriers between functions. This may be due to the different cultures which have developed over the years. Lack of integration was also seen as a problem. Inertia - a difficulty in getting things moving - was seen to be a problem, as was initiative fatigue. Case A was the most advanced process focused organisation from the 3 empirical studies.

Table 4 Summary of process focused change programme parameters

Parameters	Case A	Case B	Case C
Key Enablers identified by case interviewees	Information Technology, Concurrent Engineering Teams, Leadership, Process focus, Integrated product data information environment, development of values	Competence based Process focus Value engineering Quality Background	Team based Focused Factories around the product groups
Problems identified	Lack of integration, Old functional structure difficult to break down	New organisation - still being defined	Inertia Initiative fatigue
Focus	Business process	Functional focus [plans to change to a process and competence focus]	Functional focus - planning to change to focused factories

CONCLUSION

The change from a functional organisation to a process focused organisation has raised several issues that will need to be addressed in the realignment of Manufacturing Strategy towards a process focus and a competence based view of the organisation. This has given the domain of Operations and Manufacturing Strategy an exciting opportunity to further develop the models and techniques available to incorporate these issues. Further research will seek to address these issues and incorporate all the appropriate current Manufacturing Strategy models into an 'operate' process strategy formulation model.

REFERENCES

- Checkland P and Scholes J *Soft Systems Methodology in action* John Wiley and Sons 1991
- Davenport T *Process innovation : Re-engineering work through information technology* Harvard Business School Press 1993
- De Meyer A "An empirical investigation of manufacturing strategies in European Industry" Voss C A (Ed) *Manufacturing Strategy Theory and Practice - Proceedings of the 5th International Conference of the UK Operations Management Association* June 1990 pp 555-79
- Hayes and Pisano *Beyond World Class: The new Manufacturing Strategy* *Harvard Business Review* Jan-Feb 1994 pp 77-81
- Hayes R and Wheelwright S *Restoring our competitive edge - Competing through manufacturing* John Wiley New York NY 1984
- Hill T *Manufacturing Strategy: The strategic management of the manufacturing function* MacMillan 1985
- Hout T and Carter J 'Getting it done: New roles for senior executives' *Harvard Business Review* November - December 1995
- Mauil R, Weaver A, Childe S, Smart P, Bennett J 'Current issues in Business Process Re-engineering' *International Journal of Operations and Production Management* 1995
- Mills, Platts and Gregory "A framework for the design of a manufacturing strategy process - a contingency approach" *International Journal of Operations and Production Management* Vol. 15 No. 4 pp 17-49
- Jorysz H R and Vernadat F B "CIM-OSA Part 1: Total enterprise modelling and function view", *International Journal of Computer Integrated Manufacturing* Vol. 3 No 3 1990
- Platts K "Characteristics of methodologies for manufacturing strategy formulation" PhD Thesis University of Cambridge 1990
- Porter 'Competitive Advantage: Creating and Sustaining superior performance' New York : The Free Press 1985
- Skinner W "Manufacturing - missing link in corporate strategy" *Harvard Business Review* May-June 1969

Greswell T, Maul R, Childe S, Nash Z (1998)
'A soft systems approach to the formulation of a
manufacturing strategy'

*European Operations Management Association Conference
Proceedings
Dublin 14 – 17th June 1998*

A SOFT SYSTEMS APPROACH TO THE FORMULATION OF A MANUFACTURING STRATEGY

Tammi Greswell, Roger Maull, Steve Childe, Zoe Nash
Manufacturing and Business Systems Group, University of Plymouth, UK

ABSTRACT

A three year research project was carried out into the use of manufacturing strategy methods in the UK aerospace industry. The initial study suggested that current methods did not appear to be suitable for the changing structure of the industry from a predominantly functional orientation to a business process focus. The soft systems methodology was identified as an appropriate learning system to test the above proposition. Three cycles of learning were carried out using systems concepts: The first to develop three archetypal manufacturing strategy making systems, the second to describe the empirical data derived from seven cases studies and the third to develop a modified approach to the formulation of a manufacturing strategy taking into consideration the learning experienced in the first two cycles. The paper concludes with a discussion on the validation and use of the modified approach.

MANUFACTURING STRATEGY

Manufacturing strategy was identified by Skinner (1969) as an invaluable asset in developing the competitiveness of an organisation. The paper described the use of manufacturing as a "competitive weapon" which can support or shape corporate and business strategy. In the current dynamic competitive environment, it is critical to ensure manufacturing is capable of supporting the business strategy and to develop manufacturing capabilities that will enable the organisation to remain competitive, as described by Hayes and Pisano (1994). Manufacturing strategy has received increasing interest from both academics and practitioners who are continually striving to improve their operations. This can be demonstrated by the output of academic papers and the hosting of a conference in the field by the European Operations Management Association in 1996.

Several streams have emerged over the past decade which are providing researchers with real opportunities to provide the practitioner with useful and powerful concepts and techniques to enable them to develop manufacturing as a competitive weapon. These streams have been described by Whittle et al (1994) as the market led / customer focused approach, the best practice approach and the knowledge based approach to manufacturing strategy.

The market led / customer focused approach tends to deal with the order winners and order qualifiers of products and services. The approach is well developed and is grounded in empirical research by researchers such as Hill (1984), Buffa (1984), and Hayes and Wheelwright (1984). The essence of the approach is to achieve competitive advantage by satisfying the customer's needs.

The best practice approach tends to be efficiency based and has evolved from viewing the phenomenal success of Japanese organisations. The Toyota Production System (Ohno, 1988), has had a profound effect on the development and evolution of the best practice approach. The approach comprises of a plethora of philosophies which Western organisations have adopted to try to match the operational effectiveness of the Japanese. Schonberger (1996) has developed the world class manufacturing approach and this 'label' has been adopted by many

organisations wanting to emulate their competitors. The best practice approach is characterised by the large number of change programmes which encapsulate philosophies such as Business Process Re-engineering (BPR), Total Quality Management, (TQM), World Class Manufacturing and Lean Operations. The approach uses benchmarking and performance measures as the enablers to drive through change and to identify changes required. (Neely et al, 1995).

The knowledge based approach has evolved from the view that it is unlikely that an organisation can achieve sustained competitive advantage just by emulating best practice (Hayes & Pisano, 1994). The approach considers the view that an organisation should focus on the development of core competencies within their processes, people and technology to enable the development of new markets and directions. In order to sustain competitive advantage these core competencies must be difficult to replicate (Hayes & Pisano, 1994). The approach therefore focuses on the resources and assets required for learning and the development of these competencies and capabilities. The approach has recently been reintroduced to manufacturing strategy research by Hayes and Pisano (1994), Tecce et al (1997) and Senge (1990) who developed the concept of 'The Fifth Discipline'. The concept of the learning organisation had been developed earlier by Argyris and Schon (1978).

The three approaches are not mutually exclusive and organisations will not necessarily focus uniquely on one approach and disregard the others. It has been useful to describe the manufacturing strategy domain in this way to bound and clarify the different aspects associated within the field. The three approaches have been described using systems concepts which are explained briefly later in the paper.

The aerospace industry has changed dramatically to respond to the market and competitive changes which have occurred over the past decade. To ensure that the remaining aerospace organisations survive, it is crucial that the operations practitioners utilise the powerful concepts that manufacturing strategy provides. It is therefore also critical to ensure that manufacturing strategy develops to tackle the challenges that evolve with them. The production and operation management practitioners should be provided with a set of concepts, tools and techniques which can assist them in the demanding task of formulating and implementing a manufacturing strategy.

EVOLUTION OF RESEARCH

The identification of Manufacturing Strategy as a powerful concept in the role of enhancing the competitiveness of the UK aerospace industry led to the development of three initial case studies. These case studies explored the current use and understanding of manufacturing strategy methods within the industry. The cases identified several issues which were considered worthy of additional analysis and helped to shape the research question set and subsequent research direction.

The case studies presented a dynamic view of manufacturing and the competitive environment within the UK aerospace environment. The empirical evidence reinforced the position that manufacturing strategy was critical in developing and improving the competitiveness of an organisation. The view was formed after considerations of the following:

The aerospace market has changed dramatically in the past decade due to several factors. The market has become increasingly more competitive whilst shrinking due to changes in defence policy and a fall then a rise in commercial traffic. The ending of the cold war changed the way procurement agencies place orders and the size of orders placed. This may be due to the

perceived threat of aggression diminishing and the procurement agencies having to justify their expenditure more vigorously. However the major implication for the defence industry is the move from 'cost plus' to 'fixed price' contracts (BAe publication, 1997). This has had a profound affect on the supply chain from the prime contractors through to the systems integrators, systems suppliers and component suppliers, which is evident from the massive restructuring programmes that have occurred in the industry. The industry had to focus on becoming more efficient and competitive in their operations if they were to compete in the global market place. Manufacturing strategy is a powerful tool that could and should be used in ensuring the industry is well placed to face the global challenge (BAe publication, 1997)

The structure of both the industry and individual organisations is changing dramatically. The functional orientations which have evolved over the past century from Taylor's (1911) experience are no longer appropriate for the dynamic global business environment the UK aerospace industry finds itself in. Organisations are still predominantly arranged with the segmentation of work into specialised functions and tasks. However the organisational development paradigm is shifting towards business process focused organisations (Maull et al, 1995). These organisations are breaking down functional barriers and are creating a culture of processes as opposed to functions.

One of the implications of this development for manufacturing strategy is a shift in emphasis to integration of business processes and the evolution of the manufacturing strategy formulation process to take into account the structural, infrastructural and cultural changes within the manufacturing discipline and processes. Process teams will need to align their business processes with the business and corporate strategy and due to the make up of concurrent teams with different cultures, the exposure of different points of view (weltanschauungs) will be important to ensure that barriers to implementation of any manufacturing strategy are identified and dealt with in the formulation stage. This change in emphasis is the driving force behind the research.

THE RESEARCH QUESTION

These considerations helped to form the research question and the subsequent objectives which evolved from them.

1. Are manufacturing strategy methods and techniques currently used within the UK aerospace industry?
2. Are current manufacturing strategy methods and techniques adequate for use within the changing UK aerospace industry? (Change in focus from a function to a business process focus)
3. Are there opportunities for developing the current manufacturing strategy methods to support the evolution of UK aerospace organisations from functional orientations to a business process focus?

The following objectives were developed from the research question set to direct and focus the research.

1. To critically review current manufacturing strategy literature.
2. To determine if manufacturing strategy methods and techniques are currently used within the UK aerospace industry.
3. To identify opportunities for improvement to current manufacturing strategy methods.
4. To develop a useful tool to address any findings and problems derived from the previous objectives.

The research methodology used within the research programme evolved using Meredith et al (1989) research cycle of description, explanation and testing and Checkland and Scholes' (1990) 'Soft Systems Methodology'. Meredith's cycle was used in all phases of the research, but was initially used to develop the literature review and to produce initial findings to move the research forward. Checkland's soft systems methodology was used to develop the research in three cycles using systems concepts.

DEVELOPMENT OF KEY PRINCIPLES

The following concepts were identified as key to the research.

- The development of manufacturing within the aerospace industry.
- The development, content and process of manufacturing strategy.
- Systems theory and the business process paradigm.
- The use of the Soft Systems Methodology as a tool to learn about manufacturing strategy and to identify systemically desirable and feasible modifications to current methods
- The use of case study research.

The principles were developed using three cycles of learning using systems concepts and the soft systems methodology developed by Checkland and Scholes (1990). Cycle one identified the use of manufacturing strategy within the UK aerospace industry as a 'problem situation' which was worthy of further study. Using current literature as a starting point, three manufacturing strategy archetypes were refined using root definitions and conceptual models. The archetypes were the customer focused / market led approach, the best practice approach and the knowledge based approach to manufacturing strategy.

Cycle two explored the manufacturing strategy formulation process experiences of seven aerospace organisations and provided a base to identify changes to current manufacturing strategy methods, which would be appropriate to the aerospace industry. The outcome of this cycle indicated that the majority of cases visited were involved in a mixture of the three archetypes described with no discernible structure to enable them to reap the benefits of any one archetype or of all three archetypes. Few case organisations had a formal process by which to develop their manufacturing strategy and to keep the momentum going within their change programmes. However all recognised the need and the benefits of applying strategic thinking to their manufacturing processes. The implication of the findings was that either the current manufacturing strategy methods were not presented in a manner which was compatible to the aerospace industry's evolution or that a structured systemic method which was capable of dealing with manufacturing competitiveness within a business process focused organisation was not available.

Cycle three developed a modified approach to the formulation of a manufacturing strategy from the results of cycle one and two. The approach was developed using the soft systems methodology as a frame of reference, and the concepts of systemicity, debate and continuity. The approach draws on existing manufacturing strategy methods and evolves them into a format which is compatible with a process focused organisation, i.e. one which incorporates a business process view across traditional functions and disciplines.

The approach enables the practitioner to question the current business strategy and manufacturing's contribution to achieving the targets set in the business strategy. The approach then leads the practitioner through the process of understanding the current manufacturing organisation, assimilating data from the key stakeholders, reaching consensus

on contentious issues and producing a shared understanding of the current manufacturing operation.

The next phase develops a statement of what is expected from the manufacturing organisation, linked to the business strategy and a discussion of the appropriate manufacturing strategy archetypes which could be useful and fit their particular organisation. Objectives are developed from the manufacturing strategy statement, and relevant systems which may be people based, process based or technology based (or a mixture) are identified which will have a significant role in achieving those objectives. These systems may or may not exist at this stage. The systems identified are developed into root definitions which focus the practitioner in defining exactly what the system is to deliver. The root definition is used to develop conceptual models based on the different world views expressed by the stakeholders. These conceptual models are compared with the real world situation to identify systemically feasible and desirable changes to the current manufacturing organisation in line with the business strategy and manufacturing objectives. The mechanism chosen to deliver the approach was a facilitated workbook which was tested and validated in two organisations, using the criteria that research should be useful to practitioners within the production and operations management domain.

FINDINGS

The approach was successfully validated in two organisations through the use of discussion, focus groups and workshops. The validation played an important role in developing the usability of the approach, as the concepts underpinning the approach were designed to be useful to operations and production management practitioners. The development of a rich picture of the manufacturing operation in both organisations exposed different worldviews which were held by the key stakeholders. This was felt to be extremely beneficial in future stages of the approach when identifying the preferred direction of manufacturing and the systems required to deliver the strategy. Both organisations articulated the usefulness of the structure of the approach and the identification of relevant systems to support the business strategy and manufacturing objectives very useful. The practitioners felt that the use of systems concepts and the principles of debate, continuity and systemicity was beneficial in developing an understanding of the current manufacturing operation and the required changes to support the business strategy being followed.

RESULTS

The contribution of the work comes from the critical evaluation of existing manufacturing strategy methods and techniques. This evaluation determined that the current manufacturing strategy methods could be further developed to enable the evolving aerospace industry to meet the competitive demands they are currently facing. These opportunities for improvement were identified which were incorporated into an improved method for formulating a manufacturing strategy. The method addressed some of the issues identified.

The method makes use of three manufacturing strategy archetypes, developed using systems theory, to ensure the thinking surrounding the manufacturing strategy is made explicit and is systemic. The three archetypes have been incorporated into a manufacturing strategy meta model which describes the linkages and suggests the preferred position of each archetype in the manufacturing strategy hierarchy. The mechanism for disseminating the contribution was a workbook. The modified approach to manufacturing strategy formulation has been successfully validated on the premise of the work being useful to the practitioner and has been identified as being a useful and exciting approach to formulating manufacturing strategy. The approach was developed for use within the UK aerospace industry, however the practitioners involved in the

validation believe the approach could be useful in other sectors of industry. The approach will continue to be developed in industry.

DISCUSSION AND FUTURE RESEARCH

The modified approach developed for the formulation of a manufacturing strategy using systems concepts was well received by the industrial validators and addresses some of the concerns expressed around current manufacturing strategy methods. i.e. the exposure of different world views of the stakeholders within the manufacturing organisation, and the explicit description of the systems under consideration taking into account the people, process and technology dimensions. The approach does not solve all the issues surrounding manufacturing strategy formulation as the concept requires effort and creativity to develop a successful manufacturing strategy. The approach guides the practitioner in such a way as to question and expose the current role of manufacturing and to use systems concepts to help to formulate a way forward. The approach will be continually updated and amended through testing in other industrial sectors.

REFERENCES

- Argyris, S and Schon D (1978) *'Organisational Learning: a theory of action perspective'* Reading MA Addison and Wesley
- Buffa E (1984) *'Meeting the competitive challenge: manufacturing strategy for US Companies'* Macmillan
- Checkland and Scholes (1990) *'Soft systems methodology in action'* Wiley and sons UK
- Hayes, R and Wheelwright, S (1984) *'Restoring our competitive edge: competing through manufacturing'* Collier Macmillan NY
- Hill T (1984) *'The strategic management of the manufacturing function'* Macmillan UK
- Mauil R, Weaver A, Childe S, Smart P, Bennet J (1995) 'Current issues in business process re-engineering' *International Journal of Operations and Production Management* 15 (11) pp 37-52
- Meredith J R, Raturi A, Amoako-Gyampah K, Kaplan B (1989) 'Alternative research paradigms in operations' *Journal of Operations Management* vol. 8 no 4 pp 297-327
- Ohno T (1988) *Toyota production system : beyond large-scale production* Productivity Press
- Schonberger, R J. (1996) *'World class manufacturing: the next decade: building power, strength, and value'* New York : Free Press, 1996. 0-684-82303-9
- Senge PM (1990) *'The fifth discipline: the art and practice of the learning organisation'* Doubleday / Century New York
- Skinner W (1969) 'Manufacturing - the missing link in corporate strategy' *Harvard Business Review* May-June pp 136-45
- Teece DJ, Shuen A, Pisano G (1997) 'Dynamic capabilities and strategic management' *Strategic Management Journal* 18 (7)
- Whittle et al (1994) 'Regenerating competitive performance - strategy of capability building? A thematic approach to the regeneration of manufacturing competitiveness' *paper presented to the EurOma conference on operations strategy and performance* Churchill college, University of Cambridge June 27-29
- Hayes RH and Pisano GP (1994) 'Beyond world class manufacturing - the new manufacturing strategy' *Harvard Business Review* Jan-Feb. pp 77-86.
- Neely A, Gregory M, Platts K (1995) 'Performance Measurement System Design A Literature Review and Research Agenda' *International Journal of Operations and Production Management* 15 pp 80-116
BAe publication, 1997
- Taylor F (1911) *'The principles of scientific management'* New York Harper

Greswell T, Childe S, Maul R (1998)
'Three Manufacturing Strategy Archetypes - A Framework
for the UK Aerospace Industry'
IFIP WG 5.7 Working conference 1998, 26 – 28 August,
Marine Highland Hotel, Troon

Three Manufacturing Strategy Archetypes - A Framework for the UK Aerospace Industry

T Greswell, S Childe, R Maull

*Manufacturing and Business Systems, University of Plymouth,
Drake Circus, Plymouth, PL4 8AA, UK, Tel: 44-1752-232546,
Fax: 44-1752-233505, Email: tgreswell@plym.ac.uk*

Abstract

The paper reports on an aspect of work carried out into manufacturing strategy in the UK aerospace industry, which is reported in the thesis 'A soft system approach to the formulation of a manufacturing strategy'. This paper concentrates on the development of three manufacturing strategy archetypes and of a framework to describe the potential use of these archetypes within the UK aerospace industry. The paper describes the changing requirements of the industry when considering manufacturing strategy. The paper includes the development of the archetypes using systems theory, and reports on the contribution made to the field of manufacturing strategy making.

Keywords

Manufacturing strategy, UK aerospace industry, archetypes

1. INTRODUCTION

Manufacturing strategy is a powerful concept that enables organisations to make optimum use of the manufacturing capabilities within their people, processes and technology dimensions, to support business strategy and to develop new markets. The concept can be traced back to Skinner's seminal paper (1969) which described the use of manufacturing as a competitive weapon, as opposed to a function that is passive to its competitive environment. The UK aerospace industry has changed and still is changing dramatically to adapt to the competitive environment. This has changed the way aerospace organisations approach and perceive operations management and how to achieve competitive advantage

through manufacturing competencies. The industry has several unique characteristics, which are a result of the industry's evolution, products and technologies. The objective of the paper is to describe the development of three manufacturing strategy archetypes and the subsequent use of the archetypes within one case study.

2. CHARACTERISTICS OF MANUFACTURING WITHIN THE UK AEROSPACE INDUSTRY

The past decade has been turbulent for the industrial base within the UK as a whole. The UK aerospace has gone through a major restructuring programme from small component suppliers through to the prime contractors. In the defence sector, contracts are awarded on a fixed price basis as opposed to the traditional cost plus contracts that were enjoyed previously. Aerospace companies have suffered from over capacity with a shrinking market. This challenge has produced an aerospace industry that has recognised the importance of improving the value chain through manufacturing. These organisations are predominantly becoming less functional, with a mixture of projects, processes, and disciplines.

3. MANUFACTURING STRATEGY

The work reported in this paper critically evaluated the use of current manufacturing strategy methods within the industry and gathered empirical evidence from three initial case studies in the aerospace industry. This evidence suggested that current manufacturing strategy methods required development to enable the industry to meet the challenges of globalisation, concurrent engineering and the move to a mixture of business process, project focused and functional organisation. Three manufacturing strategy archetypes were identified from the literature by Whittle et al (1994).

Systems theory was identified as a suitable medium by which to describe and develop the three archetypes. This would ensure a frame of reference throughout the research to provide a firm link with business processes and business process focused organisations through systems concepts. Checkland and Scholes' (1990) soft systems methodology was used as the learning mechanism, cycle one of which is presented in this paper.

4. THREE MANUFACTURING STRATEGY ARCHETYPES

The manufacturing strategy archetypes evolved from three archetypes initially presented by Treacy and Wiersema (1995) as operational excellence, product leadership and customer intimacy. These have been described by Whittle et al (1994) as: the market led / customer-focused approach, the best practice approach,

and the knowledge based approach. A summary of the three manufacturing strategy-making systems is included in table 1.

Table 1 Comparison of three archetypal manufacturing strategy making systems

	<i>market led / customer focused</i>	<i>best practice</i>	<i>knowledge based</i>
World-view	manufacturing companies must satisfy the demand of their customers and markets to be competitive	manufacturing companies must be on a par with their competitors to be competitive	The knowledge created and held within an organisation is its greatest strategic asset
Inputs	customer requirements, marketing information, business objectives order winning and qualifying criteria, product family data manufacturing performance data on the key winning and qualifying criteria	current industrial benchmark information, current manufacturing systems made up of people, processes and technology	Business needs, current competitive profile, future competitive profile, skills and knowledge audit,
Output	design of the manufacturing system to support order winners and order qualifiers to align with customer expectations depending on price, quality, delivery reliability and flexibility action plan	change to the manufacturing organisation [people, processes and technology] required to move the organisation to becoming the benchmark	Manufacturing strategy – identifies current capabilities / competencies and future requirements for manufacturing Team and individual learning
Mechanisms	Business process re-engineering, Total quality management, Quality awards, Manufacturing audits, European Foundation for Quality Management, Hills manufacturing strategy (1985) methodology, Platts and Gregory (1994) methodology, Competitive profiling	Benchmarking, Identification of best practice, European Foundation for Quality Management, Manufacturing audits, Gap analysis, Performance measures, World class manufacturing, Business process re-engineering to achieve step change or radical change, Total quality management - incremental improvement	Skills audits Technology audits Process audits Manufacturing audits The learning organisation Concurrent engineering

In this research each archetype was characterised using systems concepts in order to define the boundaries and key parameters for each. The benefit of developing the archetypes in this way is to enable the operations management practitioner to determine which current archetype is predominant within their approach. This in turn enables the practitioner to identify if any other facets in the approaches that are not currently predominant would be suitable for their manufacturing operation to enhance the value chain, or to determine whether a transformational view incorporating all of the archetypes is beneficial. It is

interesting to consider the following when taking the archtypical view of manufacturing strategy:

1. Does each manufacturing strategy archetype have a preferred use within different parts of an organisation, i.e. whether the manufacturing operation is process, function or project based, or a mixture?
2. Do the archetypes sit within a hierarchy of manufacturing strategies?
3. Can each archetype be used singly to provide the organisation with maximum benefit or is an integrated approach more beneficial?

Each archetype is described in systems terms, to enable a comparison to be made between the three manufacturing strategy making systems identified. Each strategy making system is described using a root definition, i.e. a statement in the format 'a system to do x by means of y in order to achieve z'.

4.1 The customer focused/market led manufacturing strategy making system

A root definition for the customer-focused/market led market led manufacturing strategy-making system is: 'A system to produce a manufacturing strategy, which enables the alignment of the manufacturing organisation to support the business strategy, by means of identifying relevant product groups, identifying order winners and order qualifiers for each product group and aligning the manufacturing organisation as necessary, in order to achieve customer satisfaction and through customer satisfaction, competitive advantage.'

The system is characterised by a focus on the customer's needs as the primary driver for the identification of order winners and order qualifiers. These may include quality, for example conformance to requirements, delivery reliability for example short lead-times, delivery flexibility for example to fit in with a customer's JIT philosophy, and product variability. These characteristics are fed into the key decision areas as defined by Hayes and Wheelwright (1984) to enable the alignment of the manufacturing organisation to the customer requirements. This is described by Hill (1984) as the infrastructure and structure of manufacturing and includes aspects such as process choice.

This system aligns to the customer intimacy archetype as described by Treacey and Wiersema (1995). This is underpinned by the philosophy that getting close to the customer and meeting and or exceeding customer requirements will enable the building of a sustainable competitive advantage. This system has been characterised by Whittle et al (1994) as the 'Outside-In' approach to manufacturing strategy. The organisation has predominately an outward looking perspective and keeps a sharp eye on the market requirements to ensure the manufacturing organisation is aligned to support those requirements. Due to this

alignment, marketing is a key stakeholder within this archetype and problems may occur if the marketing department has a different view of what manufacturing should deliver compared to the views of manufacturing. The importance of the customer is key, with the quality systems and business processes being aligned to the customer requirements.

4.2 The best practice manufacturing strategy making system

A root definition for the Best Practice strategy making system is: 'A system to produce a manufacturing strategy by identifying and implementing current best practice manufacturing philosophies and techniques by means of competitive benchmarking and the business excellence models to improve the competitive position of the organisation'

This system is characterised by developing people, process and technology excellence in order to delivery operational excellence. The underlying principles focus on an organisation striving to become the benchmark for their current industry. This is achieved by emulating best practice, identifying the gaps within current manufacturing dimensions concerning people, process and technology, and driving through changes which will enable the organisation to be on a par with the best in the industry. This is characterised by Camps' work (1989) as the 'search for best practices, which cumulatively lead to superior performance'. The Best Practice archetype corresponds to Treacey and Wiersemas' (1995) operational excellence, which is based upon the philosophy that achieving operational excellence will enable the building of a sustainable competitive advantage.

4.3 The knowledge based manufacturing strategy making system

A root definition for the knowledge based manufacturing strategy making system is: 'A system to produce a manufacturing strategy which identifies, develops and nurtures technological, process and human core competencies within the manufacturing system by means of developing a learning organisation in order to stay ahead of the competition by developing new markets and directions'.

This system is still in the cradle as regarding its evolution but appears to be characterised by focusing on developing competencies around the aspects of people, process and technology, which are difficult for other organisations to replicate. As a strategy it focuses on the philosophy that by identifying and developing core competencies which are difficult to replicate it will open up new markets which will have high barriers to entry for other competitors.

This will lead to a sustainable competitive advantage, as no other organisation will be able to match the critical characteristics of the organisation, that are

intrinsic within its core competencies. This is described by Prahalad and Hamel (1990), Hayes and Pisano (1994) and Teece, Shuen and Pisano (1997).

The system corresponds to the product leadership Treacey and Wiersema (1995) archetype, which is characterised by the philosophy that by achieving product leadership will enable the building of a sustainable competitive advantage.

5. CASE STUDY OF THE USE OF THREE MANUFACTURING STRATEGY ARCHETYPES

The case study is a complex organisation that is split along three main dimensions within the value chain. These include customer projects, internal supply and functions. Internal supply provides kit sets and parts to the customer projects and the functions are responsible for people and process excellence. Due to the complexity of the business and the different requirements for each customer project, developing a manufacturing strategy has taken several streams. The outcome of the manufacturing strategy has emerged as three levels which map onto the three manufacturing strategy archetypes described earlier.

The strategy making that occurred in this case, identified the core competencies that were required within each location of the organisation, which were mapped onto future market requirements to provide a tiering system throughout the organisation. Each manufacturing tier corresponds to a tier within the value chain. The make or buy element of manufacturing strategy was built around the identification of current competencies and which of these would be kept in house as strategic competencies. The above slots into the knowledge based manufacturing strategy archetype.

The market led / customer focused manufacturing strategy archetype was linked to the customer projects manufacturing processes. Manufacturing strategy making for a major new project used the concepts of order winners and order qualifiers to align the new manufacturing processes required to deliver the performance required by the customer. Delivery reliability was identified as key and the manufacturing system was developed using lean manufacturing as the philosophy.

The best practice manufacturing strategy archetype was evident throughout the manufacturing organisation. The business excellence model was used to identify key business enablers which included the manufacturing process, this incorporated the continuous improvement philosophy, and the manufacturing engineering process which incorporated a journey from learner to world class for each manufacturing business. Each manufacturing business reports on their

progress monthly which enables the sharing of best practice throughout the organisation.

The three archetypes appear to fall into a manufacturing strategy hierarchy. The knowledge-based approach was used to set the main direction for each manufacturing tier within the business. The market led/customer focused approach was used within individual projects to align products to the customer requirements. The best practice approach was used within internal supply to continuously strive for greater efficiency.

6. DISCUSSION AND FUTURE RESEARCH

The examples described above map onto the three archetypes. The archetypes are useful in providing the operations management practitioner with a framework to provide focus. The introduction of archetypes may be useful when formulating a Manufacturing Strategy to provide other views. The experience of the case organisation is that managing the complexity within the manufacturing process and ensuring the organisation gains the maximum benefit from the manufacturing organisation from the dimensions of people, processes and technology is very difficult. The three archetypes provide a focus for the organisation and provide the practitioner with reference points and other directions if appropriate. To answer the questions posed at the beginning of the paper.

1. It appears from the case study that the three manufacturing strategy archetypes do have a preferred use within the different parts of the case organisation, however there is overlap between the three archetypes that would be expected.
2. The case study suggests that the three archetypes sit within a hierarchy, however more case studies would be needed to substantiate this view.
3. It would appear from the evidence provided from the case study that all three archetypes provide each part of the organisation with benefits. However the benefits of using an integrated approach are also evident from the performance of the overall organisation.

7. REFERENCES

- Camp, C. (1989) Benchmarking: the search for best practices which lead to superior performance - parts 1 to 5, *Quality Progress*, Jan-May
- Checkland, P and Scholes, J (1990) *Soft systems methodology in action* Wiley and sons UK
- Hayes RH and Pisano GP (1994) Beyond world class manufacturing - the new manufacturing strategy *Harvard Business Review* Jan-Feb. pp 77-86.

- Hayes, R and Wheelwright, S (1984) *Restoring our competitive edge: competing through manufacturing* Collier Macmillan NY
- Hill T (1984) *The strategic management of the manufacturing function* Macmillan UK
- Mills J Platts K Gregory M (1995) A framework for the design of manufacturing strategy processes *International Journal of Operations and Production Management* 15(4) 17-49
- Prahalad, C.K. and Hamel, G. (1990) The Core Competence of the Corporation, *Harvard Business Review*, Vol. 68, May-June, pp. 79-91
- Skinner W (1969) Manufacturing - the missing link in corporate strategy *Harvard Business Review* May-June pp 136-45
- Teece DJ, Shuen A, Pisano G (1997) 'Dynamic capabilities and strategic management' *Strategic Management Journal* 18 (7)
- Treacy and Wiersema (1995) *Discipline of market leaders* Harper Collins
- Whittle et al (1994) Regenerating competitive performance - strategy of capability building? *EurOma conference on operations strategy and performance* Churchill college, University of Cambridge June 27-29

8. BIOGRAPHY

Tammi Greswell is a research assistant at the University of Plymouth currently employed on a grant developing a methodology for process based change within Small to Medium Sized Manufacturing Enterprises

Dr Childe is a joint leader (with Dr Maull) of the Manufacturing and Business Systems research group at the University of Plymouth. His research interests include production management and manufacturing systems, intervention methodologies, implementation, and human aspects. He has held various research grants including currently *a methodology for the re-engineering of business processes*. He is the author of *An introduction to Computer Aided Production Management* and a member of IFIPs working group 5.7 on computer aided production management.

Dr Roger Maull is a joint leader (with Dr Childe) of the Manufacturing and Business Systems research group at the University of Plymouth. His research interests are based within systems theory. Topics include Business Process Re-engineering, systems and enterprise modelling, all types of operations and production management TQM, and approaches to organisational culture analysis. He is a principal investigator on one EPSRC, one EPSRC IMI and a co-investigator on an ESRC Innovation research project.

Greswell T, Childe S, Maul R, Smart P (1998)
'The development of three manufacturing strategy-making
systems'
presented at MIM 98 University of Nottingham

THE DEVELOPMENT OF THREE MANUFACTURING STRATEGY MAKING SYSTEMS

T J Greswell, S J Childe, R S Maull, P A Smart
Manufacturing and Business Systems Group, University of Plymouth, Drake Circus,
Plymouth PL4 8AA Devon
E-mail: T.Greswell@plym.ac.uk

ABSTRACT

As part of a research programme into the current use of manufacturing strategy methods in the UK aerospace industry, three manufacturing strategy making systems were developed from the literature to enable a comparison to be carried out between eight empirically derived cases and three manufacturing strategy archetypes. The systems were used as building blocks within a modified approach to developing a manufacturing strategy using soft systems thinking and other systems methods. The approach was delivered as a workbook and validated in two aerospace organisations and one SME. This paper aims to describe the development of the three manufacturing strategy making systems and describes how they are used within the soft systems approach to developing a manufacturing strategy.

1 Introduction

The paper describes the development of three manufacturing strategy making systems using systems concepts and the soft systems methodology. The development was carried out as part of a piece of EPSRC-funded PhD research entitled 'A soft systems approach to the formulation of manufacturing strategy', which investigated the use of current manufacturing strategy methods within the UK aerospace industry. A preliminary study suggested that current methods did not meet the needs of the UK aerospace practitioner. These needs appeared to be increasingly linked with business process focused organisations, concurrent engineering teams and a change from a functional view of manufacturing to one of a seamless integrated product development and order fulfilment process. This resulted in the development of three manufacturing strategy making systems which were used in the development of a modified approach to the formulation of a manufacturing strategy using systems concepts. These systems were compared with eight empirical cases derived from the experiences of practitioners within the UK aerospace industry to identify feasible changes to current methods used for formulating manufacturing strategies. These changes were incorporated into a modified approach and validated within three organisations using a workbook.

2 Research Method

The research method used for the development of the manufacturing strategy making systems followed Meredith et al's [1989] cycle of description, explanation and testing. The systems were described using the current manufacturing strategy literature, developed into conceptual models using Checklands' [1991] Soft Systems Methodology, and compared with eight case studies derived from the experiences of the UK aerospace practitioners.

3 Underpinning principles

The principles underpinning the development of three manufacturing strategy making systems included manufacturing strategy literature and systems theory.

3.1 Manufacturing strategy

Manufacturing strategy has been defined as 'the *decisions and plans affecting resources and policies directly relating to the sourcing, production and delivery of tangible products*' (Swink and Way, 1995). Another definition presented by Swamidass and Newell (1987) is 'the *effective use of manufacturing*

strengths as a competitive weapon for the achievement of business and corporate goals'. Manufacturing strategy can be described as both a journey and a direction, with the direction being the focusing of the manufacturing operation within its market and competence base, and the journey encompassing the methods used to achieve that focus. The journey can be a specific change programme, for example.

A manufacturing strategy can also be a useful concept in enabling an organisation to position its people process and technology to enable the development and creation of new markets (Hayes and Wheelwright, 1984). The need to have a vision of the future and to be able to plan to be competitive in that future has always been important (Mintzberg 1994). Changes in the global economy mean that no organisation can afford to be complacent. Organisations such as Caterpillar never expected to be overtaken by Komatsu, General Motors by Honda or Xerox by Canon.

Manufacturing is a critical value-adding operation within many organisations and the ability to develop and sustain manufacturing capabilities to support and/or to develop the strategic direction of that organisation is an asset. Poor operating performance has been attributed not only to operating inefficiencies but also to poor strategic decisions (New & Myers, 1986).

3.2 Systems theory

Typically, scientific research has been based on the concept of rationalism and reductionism as the appropriate method of determining solutions to scientific problems. This method can be described as a systematic approach to problem solving. This type of reductive analysis has been described by Wilson (1984) as *'the most successful explanatory technique used in science'*.

Systems thinking has been developed as a method which supplements this reductionism but looks at 'wholes or holons' and their emergent properties as opposed to breaking them down into their component parts and analysing each part in isolation. The main objective of systems thinking as described by Wilson (1984) is *'the attainment of public knowledge of the kind which science accumulates by means of a modified scientific approach in which a form of holism replaces reductionism'*. Systems thinking has evolved as a method which aims to make thinking explicit by observing activity and taking into account the world view or 'Weltanschauung' which makes that activity meaningful. Kant (1781) articulated this thus: *'observed activity is only meaningful to us in terms of a particular image of the world'*

Systems thinking incorporates several constructs to aid the strategist / analyst in thinking holistically. These include the concepts of hierarchies, emergent properties, communication and control, and thinking with 'holons'. Systems theory also provides the strategist / analyst with attributes to help structure the analysis in a way, which makes the thinking explicit. The attributes of a system as identified by Churchman (1971) are the 'objectives, environment, resources, components and management' of the system. The three manufacturing strategy making systems were developed using the concepts outlined above. A soft systems approach was considered beneficial because of the cycles of learning which are incorporated into the approach. It is important to underpin this rationale by explaining the main differences between hard systems and soft systems thinking.

3.2.1 Hard Systems Thinking (HST) and Soft Systems Thinking (SST)

HST views the real world as being systemic and uses systematic tools and techniques to analyse the system under consideration. 'Systemic' means taking a holistic view of the system and 'systematic' means to take a step by step methodological view. This type of systems thinking can be described as the 'optimisation paradigm' Wilson (1984). Engineering problems are typically solved using HST, a need is defined and objectives are stated.

When hard systems concepts were applied to human activity systems such as organisations, the methods used were not able to provide suitable solutions to problems which were described as 'ill defined, ill structured and messy' (Checkland, 1990). The identification of this led to the development of the Soft Systems Methodology [SSM]. The view that traditional systematic methods were not sufficient to solve complex, ill defined and messy problems was acquired from experiences in developing new technologies in the manufacturing sector. Problems were experienced in implementing

technological systems which had been robustly designed. It was observed that the problems were mainly due to human factors and a method was devised to address the 'problem situations' in human activity systems.

Soft systems thinking in contrast to HST, views the world as problematic and an ill-defined situation [a problem situation] which can be tackled using certain constructs to aid learning and understanding. This line of enquiry about the 'problem situation' leads to systemically feasible changes. SST was developed as a possible solution to the problem of using HST to tackle messy and ill structured problems which are predominant in organisations and is described as a process of enquiry and learning (Checkland, 1990). The approach has been developed by several authors notably Checkland (1981), Wilson (1984), Ackoff (1981) and Boardman (1984) and include the key principles of participation and debate, continuity and systemicity.

The principle of participation encourages the strategist / analyst to include all stakeholders who have an interest in the system being analysed, or an impact in the implementation of any solution or change identified to that system as a result of the manufacturing strategy. This could benefit the manufacturing strategy process, with the inclusion of key stakeholders of the manufacturing system which would incorporate the people, process and technology aspects of the human activity system. This enables different views of what manufacturing should or could achieve to contribute to the competitiveness of the organisation to be exposed and considered in the process of formulating a manufacturing strategy. The principle of debate encourages the stakeholders to participate in the formulation process to expose possible 'blockers' to the successful implementation of the strategy. The principle of continuity encourages an approach which is seen as a cyclic process of learning. This involves looking at the process of manufacturing strategy formulation as a system which is evolving and incorporates the human activity system (the organisation) and the decision areas of manufacturing as abstract and physical systems.

The principle of systemicity encourages the strategist / analyst to view the whole picture, to consider the relationships between the relevant systems and to consider how certain outcomes will affect the whole system. The Soft Systems Methodology (SSM) was developed by Checkland (1984) to address these principles. SSM can be described as a learning system, which exposes different views of the world which are then debated with the conceptual models. This process leads to the identification of feasible changes to the system under review. The above principles have been used to develop three manufacturing strategy making systems, which are summarised in the remainder of the paper.

4 Development of three manufacturing strategy making systems

Three archetypes identified by Whittle et al (1994) from the current manufacturing strategy literature were used as the foundation for the development of three manufacturing strategy making systems. These include the market led/customer focused approach, the best practice approach and the knowledge based approach. The approach is summarised below.

Step 1 – develop rich picture. A rich picture shows the key relationships, issues, content and influences surrounding each archetype.

Step 2 – develop root definition To provide a concise statement of the manufacturing strategy making systems under investigation, To ensure focus is not lost, to provide the boundary to the system in question. A system to do x by means of y in order to achieve z

Step 3 – development of systems parameters To identify the sources, inputs, transformations, outputs, receivers and feedback elements within the system, to enable the development of conceptual models

Step 4 – development of systems concepts To identify the objective, worldview, boundaries and management issues, including hierarchy and communication & control, to enable the development of conceptual models

A summary of the systems are shown below:

4.1 Rich Pictures:

The rich pictures describe the essential essence of the different manufacturing strategy making systems

Market led / customer focused manufacturing strategy making system



Best practice manufacturing strategy making system

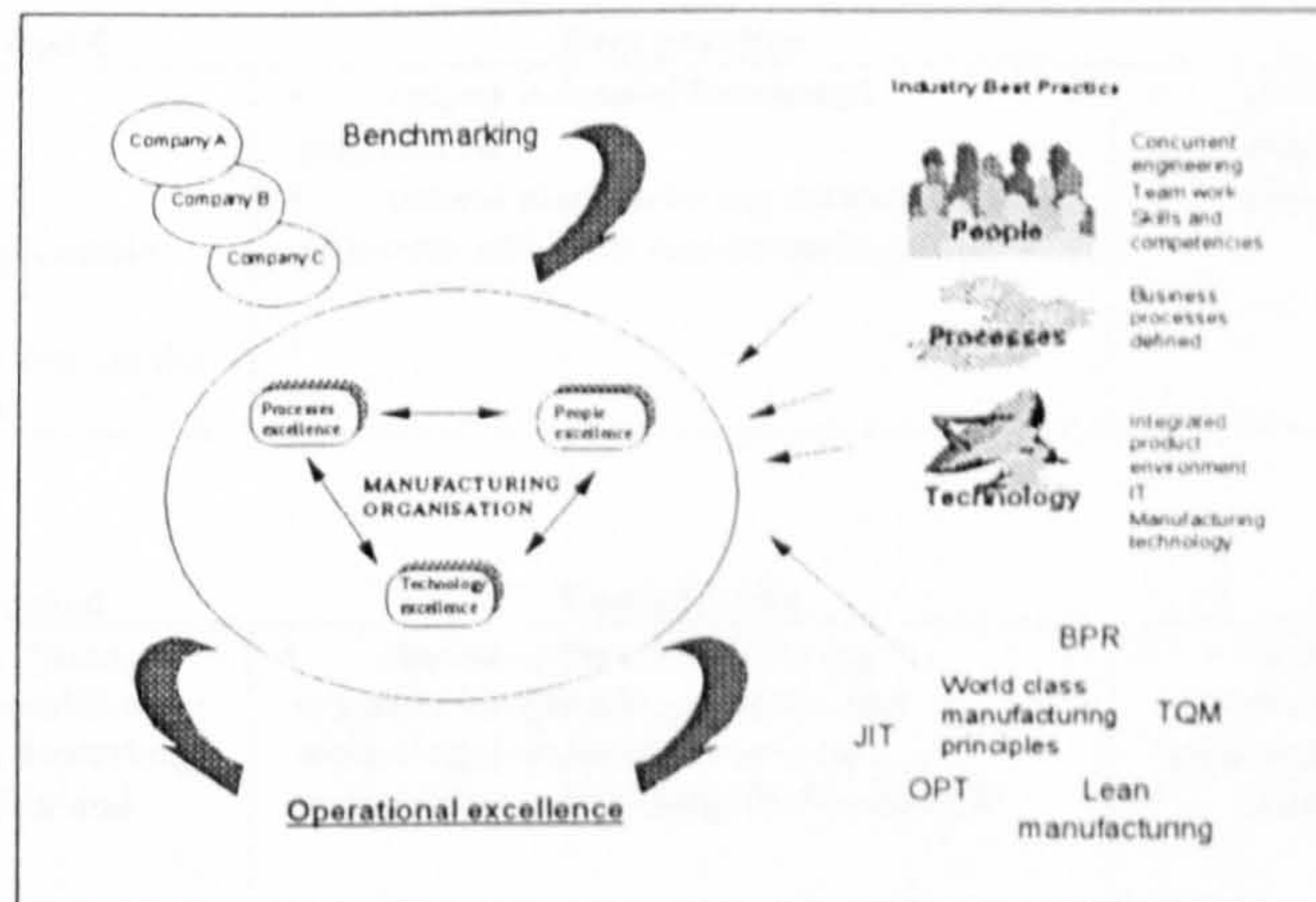

Knowledge based manufacturing strategy making system

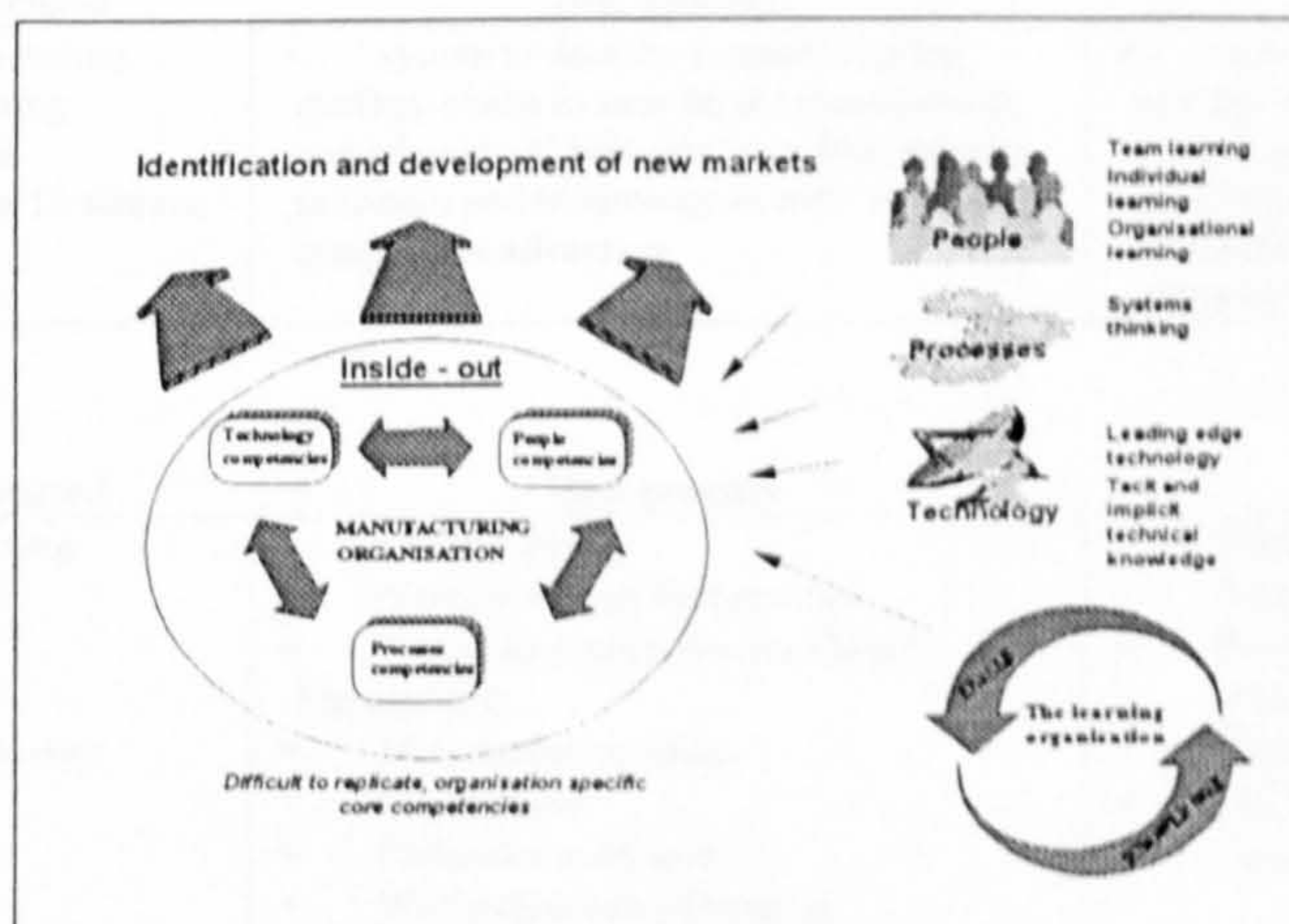

4.2 Root definitions

Market led / customer focused manufacturing strategy making system

Best practice manufacturing strategy making system

Knowledge based manufacturing strategy making system

<p><i>'A manufacturing strategy-making system developed to produce a manufacturing strategy, which enables the alignment of the manufacturing organisation to support the business strategy. By means of identifying relevant product groups, identifying order winners and order qualifiers for each product group and aligning the manufacturing organisation. In order to achieve customer satisfaction and through customer satisfaction, competitive advantage.'</i></p>	<p><i>'A manufacturing strategy making system developed to produce a manufacturing strategy which identifies current best practice within the people, process and technology elements of the manufacturing system and implementing current best practice manufacturing philosophies and techniques. By means of competitive benchmarking and continuous improvement of the people, processes and technology elements within the manufacturing system. In order to improve the competitive position of the organisation by becoming a world class organisation and the industry benchmark.'</i></p>	<p><i>'A manufacturing strategy making system developed to: produce a manufacturing strategy which identifies, develops, and nurtures technological, process and human core competencies. For example the skills and knowledge which are difficult to replicate) within the manufacturing system. By means of: skills and knowledge audits, which are compared to the current skills and knowledge, held within the organisation. A gap analysis is undertaken which identifies where development is required to meet the objectives of the business. In order to: stay ahead of the competition by developing new markets and directions from those core competencies, and from these new markets, competitive advantage.'</i></p>
---	--	---

4.3 Systems Parameters

Inputs

Market led / customer focused	Best practice	Knowledge based
<ul style="list-style-type: none"> ▪ customer requirements ▪ marketing information ▪ business objectives ▪ order winning and qualifying criteria ▪ product family data ▪ manufacturing performance data on the key winning and qualifying criteria 	<ul style="list-style-type: none"> ▪ current industrial benchmark information ▪ current manufacturing systems made up of people, processes and technology 	<ul style="list-style-type: none"> ▪ business needs ▪ current competitive profile ▪ future competitive profile

Outputs

Market led / customer focused	Best practice	Knowledge based
<ul style="list-style-type: none"> ▪ design of the manufacturing system to support order winners and order qualifiers to align with customer expectations depending on price, quality, delivery reliability and flexibility ▪ action plan 	<ul style="list-style-type: none"> ▪ change to the manufacturing organisation [people, processes and technology] required to move the organisation to becoming the benchmark 	<ul style="list-style-type: none"> ▪ manufacturing strategy - identifies current capabilities / competencies and future requirements for manufacturing ▪ team and individual learning

Outcome

Market led / customer focused	Best practice	Knowledge based
<ul style="list-style-type: none"> ▪ system to develop a manufacturing strategy which focuses on delivering customer satisfaction through the manufacturing capability in order to achieve competitive advantage 	<ul style="list-style-type: none"> ▪ system to develop a manufacturing strategy which focuses on the identification and adoption of best practice within people, processes and technology in order to deliver a competitive advantage 	<ul style="list-style-type: none"> ▪ system to develop a manufacturing strategy which focuses on the core competencies [people] and core capabilities [processes and technology] of the wider manufacturing systems to achieve competitive advantage

Mechanisms

Market led / customer focused	Best practice	Knowledge based
<ul style="list-style-type: none"> ▪ Business process re-engineering ▪ Total quality management ▪ Quality awards ▪ Manufacturing audits ▪ European Foundation for Quality Management ▪ Hills methodology ▪ Cambridge methodology ▪ Competitive profiling 	<ul style="list-style-type: none"> ▪ Benchmarking ▪ Identification of best practice ▪ European Foundation for Quality Management ▪ Manufacturing audits ▪ Gap analysis ▪ Performance measures ▪ World class manufacturing ▪ Business process re-engineering to 	<ul style="list-style-type: none"> ▪ Skills audits ▪ Technology audits ▪ Process audits ▪ Manufacturing audits ▪ Spider diagrams ▪ The learning organisation ▪ Concurrent engineering

	achieve step change or radical change • Total quality management - incremental improvement	
--	---	--

Constraints

Market led / customer focused	Best practice	Knowledge based
<ul style="list-style-type: none"> Change in customer requirements 	<ul style="list-style-type: none"> Change in competitors best practice Identification of new working practices, processes technology, skills and knowledge 	<ul style="list-style-type: none"> Change in competencies required

Elements of CATWOE –

Market led / customer focused	Best practice	Knowledge based
<i>Actors</i>		
<ul style="list-style-type: none"> manufacturing / operations directors, senior managers, marketing organisation, customer, manufacturing systems designer 	<ul style="list-style-type: none"> manufacturing / operations directors, senior managers, manufacturing systems designer, all manufacturing operations personnel 	<ul style="list-style-type: none"> all manufacturing operations personnel
<i>Worldview</i>		
<ul style="list-style-type: none"> manufacturing companies must satisfy the demand of their customers and markets to be competitive 	<ul style="list-style-type: none"> manufacturing companies must be on a par with their competitors to be competitive 	<ul style="list-style-type: none"> the knowledge created and held within an organisation is its greatest strategic asset
<i>Owner</i>		
<ul style="list-style-type: none"> manufacturing / operations directors 	<ul style="list-style-type: none"> manufacturing / operations director 	<ul style="list-style-type: none"> the organisation

Systems concepts

<i>Environment – wider system</i>		
manufacturing's role within the organisation - Hayes & Wheelright rating 1 - 4	manufacturing's role within the organisation - H&W rating 1 - 4	H&W - 4 - Externally supportive
<i>Hierarchies</i>		
Corporate strategy - business strategy - manufacturing strategy - top down approach	bottom up approach	holistic - top down and bottom up approach
<i>Communication and control</i>		
Information from the market which affects the order winners and qualifiers	Information from outside sources concerning people, processes and technology best practice	knowledge and skills within the organisation shape the strategic direction

5 Discussion

The three manufacturing strategy making systems are used to compare the experiences of eight case studies carried out within the UK aerospace industry. The cases were compared with the conceptual models to identify two things. Whether the current models of manufacturing strategy are appropriate for the challenges facing the emerging process focused organisations, and whether a modified approach to manufacturing formulation would be beneficial to individual organisations within the UK aerospace industry.

6 Results

The three systems were tested against the results of eight case studies, which were empirically derived. These case studies identified the approach of individual organisations took, when developing and implementing a manufacturing strategy. The following changes to current manufacturing strategy formulation methods were identified as feasible and systemically desirable.

- 1 the integration of the three manufacturing strategy archetypes to enable a balanced systemic, approach which incorporates the customer, industrial best practice, core competencies and capabilities encapsulated within the people, process and technology aspects.
- 2 Taking a systems (holistic) approach in order to understand the implications and dependencies on the wider system [the organisation].
- 3 Identification of the need to identify the stakeholders in the process and their world views of manufacturing in order to enable a smoother implementation systems.

7 Conclusion

The paper concludes that the three manufacturing strategy making systems are a useful framework for a practitioner to identify their own current methods and to identify others. The use of systems concepts enables the tackling and representation of complex issues inherent within manufacturing strategy development and implementation.

Future work will test and develop the idea of the manufacturing strategy making system as a cycle of learning in order to ensure a long term view is encouraged, and to enable the concepts of the learning organisation [now known as knowledge management] to be embedded within manufacturing.

8 References

- Ackoff R L (1981) *'Creating the corporate future'* J Wiley and Sons New York
- Boardman J T (1995) 'Wholes and parts – a systems approach' *IEEE Transactions on systems, man and cybernetics* Vol. 25 No 7 July
- Checkland P (1981) *'Systems thinking, systems practice'* Wiley
- Checkland P and Scholes J (1990) *'Soft systems methodology in action'* Wiley and Sons
- Churchman (1971) *'The design of inquiring systems'* Basic Books NY
- Hayes R H and Wheelwright S C (1984) *'Restoring our competitive edge: competing through manufacturing'* John Wiley New York NY
- Kant (1781) In Russell, Bertrand *'History of western philosophy: and its connection with political circumstances from the earliest times to the present'* London: Allen and Unwin, 1946.
- Meredith J R, Raturi A, Amoako-Gyampah K, Kaplan B (1989) 'Alternative research paradigms in operations', *Journal of Operations Management* (8) 4 pp 297-327
- Mintzberg H (1994) 'The fall and rise of strategic planning' *Harvard Business Review* Nov-Dec
- New C and Myers (1986) *'Managing manufacturing operations in the UK 1975-1985'* British Institute of Management
- Swamidass and Newell (1987) 'Manufacturing Strategy, environmental uncertainty and performance: a path analytical model' *Management Science* (33) 4 pp 509-24 MAN
- Swink M and Way M (1995) 'Manufacturing Strategy: Propositions, current research, renewed directions' *International Journal of Operations and Production Management* (15) 7 pp 4-26
- Whittle S, Smith S, Tranfield D, Maull R, Childe S, Martin S (1994) 'Regenerating competitive performance strategy of capability building? A thematic approach to the regeneration of manufacturing competitiveness. Paper presented to the *European Association First International Conference on Operations Strategy and Performance*, Churchill College, University of Cambridge June 27/29
- Wilson B (1984) *'Systems concepts, methodologies and applications'*

The use of the prioritisation matrix helped to rationalise the 300 issues to 30 key areas. Refer to Fig.3. These issues were presented to the manufacturing team leaders, who took the issues back to their teams to decide which ones they felt they could begin to tackle. The teams are currently addressing each issue.

	1 = More Important 0 = Equally important -1 = Less important	A	B	C	D	E	F	G	Total
A	Inadequate resources/skills	0	0	1	0	0	1	1	3
B	Lack of disciplined approach attention to detail	0	0	0	-1	-1	-1	1	-2
C	Over complication - products / processes / paperwork	-1	0	0	0	-1	0	0	0
D	No learning from past mistakes	0	1	0	0	0	1	1	3
E	Lack of accountability	0	1	1	0	0	0	1	3
F	Poor role clarity	-1	1	0	-1	0	0	1	0
G	Lack of flexibility	-1	-1	0	-1	-1	-1	0	-5

Fig.3. Example of the Priority Matrix

Examples of some of the issues developed into initiatives include:

- Blame culture, low morale, must be seen to be doing something, eliminate fear and stress
- Lack of understanding of plans and planning tools
- Task focused - achieve at any cost
- No incentive to put right what has gone wrong
- Poor definition/understanding of plans/planning tools
- Lack of communication,
- Lack of commitment to promises plans
- Design not adequately finished proven
- No learning from past mistakes
- Incorrect constitution of planning teams
- Lack of shared objectives/understanding of roles

3 THE 'BOTTOM UP' APPROACH

The bottom up approach took the 'hard system' route. In hard systems thinking the analysis is systematic, well ordered with specific rational steps. In this way the present state is defined using a specific modeling tool or technique, the desired state is defined in the same way with alternative approaches to achieve the desired state available.

The team decided to use IDEFo, the ICAM definition method [3] to model the Printed Circuit Board (PCB) manufacturing process to enable a systematic and detailed approach to defining key areas for improvement.