



2015-07-01

## Alpha-synuclein induced mitochondrial aberrations in a genetic cell culture model of Parkinson's disease

Jennifer Pinnell  
*University of Plymouth*

Follow this and additional works at: <https://pearl.plymouth.ac.uk/tpss>



This work is licensed under a [Creative Commons Attribution 4.0 International License](https://creativecommons.org/licenses/by/4.0/).

### General rights

All content in PEARL is protected by copyright law. Author manuscripts are made available in accordance with publisher policies. Please cite only the published version using the details provided on the item record or document. In the absence of an open licence (e.g. Creative Commons), permissions for further reuse of content should be sought from the publisher or author.

### Take down policy

If you believe that this document breaches copyright please [contact the library](#) providing details, and we will remove access to the work immediately and investigate your claim.

### Recommended Citation

Pinnell, J. (2015) 'Alpha-synuclein induced mitochondrial aberrations in a genetic cell culture model of Parkinson's disease', *The Plymouth Student Scientist*, 8(1), p. 4-19.

This Biomedical and Healthcare Sciences Articles is brought to you for free and open access by the Journals at PEARL. It has been accepted for inclusion in *The Plymouth Student Scientist* by an authorized editor of PEARL. For more information, please contact [openresearch@plymouth.ac.uk](mailto:openresearch@plymouth.ac.uk).

2015

# Alpha-synuclein induced mitochondrial aberrations in a genetic cell culture model of Parkinson's disease

Pinnell, J.

Pinnell, J. (2015) 'Alpha-synuclein induced mitochondrial aberrations in a genetic cell culture model of Parkinson's disease', *The Plymouth Student Scientist*, 8(1), p. 4-19.

<http://hdl.handle.net/10026.1/14081>

---

The Plymouth Student Scientist

University of Plymouth

---

*All content in PEARL is protected by copyright law. Author manuscripts are made available in accordance with publisher policies. Please cite only the published version using the details provided on the item record or document. In the absence of an open licence (e.g. Creative Commons), permissions for further reuse of content should be sought from the publisher or author.*

# **Alpha-synuclein induced mitochondrial aberrations in a genetic cell culture model of Parkinson's disease**

Jennifer Pinnell

*Project Advisor; [Kim Tieu](#), Centre for Biomedical Research, The John Bull Building, Tamar Science Park, Research Way, Plymouth, Devon, PL6 8BU*

## **Abstract**

Mutations in the  $\alpha$ -synuclein encoding gene, *SNCA*, have been implicated in the pathophysiology and progression of Parkinson's disease, a neurodegenerative disorder which results in motor and cognitive abnormalities in patients. Missense mutations, duplications and triplications of the gene relate to the onset and advancement of the ailment, but the role of  $\alpha$ -synuclein protein in the pathogenesis is incompletely understood. Recent investigation of the disease and its other associated proteins has driven interest in the role of mitochondrial abnormalities in Parkinson's disease. Through use of an ecdysone-inducible expression system in the mammalian neuronal cell line, 1RB<sub>3</sub>AN<sub>27</sub>, the detrimental effects of mutant A53T  $\alpha$ -synuclein upon mitochondrial morphology has been established, which corroborates the work of similar studies. Complementary immunocytochemistry and western blot analyses allude to the time dependent increase in protein expression and the corresponding fragmentation of mitochondria. Analysis of mitochondrial function using Seahorse XF<sup>e</sup>24 technology proved inconclusive; further work is needed to confirm the consequences of mutant A53T  $\alpha$ -synuclein expression upon mitochondrial respiratory capacity in this disease model.

## Introduction

Parkinson's disease is a common neurological disorder, characterised by the degeneration of the nigrostriatal dopaminergic pathway, which affects more than 100,000 individuals in the UK alone (Campenhausen et al, 2005). As the principle neurotransmitter of the extrapyramidal system, dopamine plays a major role in the regulation and control of motor nuclei and their associated pathways (Marieb and Hoene, 2010). Deterioration of dopaminergic neurons in the substantia nigra results in the clinically recognisable triad of Parkinson's symptoms; rigidity, resting tremor and bradykinesia (Siegel et al, 2006).

The aetiology of Parkinson's disease is still unknown, although both genetic and environmental factors have been implicated, it is thought to be a polygenic disease with various causal interactions. Through research into cases of familial Parkinson's, multiple gene mutations have been identified, some of which have been shown to adversely affect mitochondrial function (Klein and Westernberger, 2012). Abnormalities of mitochondria have been pathogenically associated with Parkinson's disease since the discovery of human parkinsonism as a result of self-administered 1-methyl-4-phenyl-1,2,3,6-tetrahydropyridine(MPTP)-contaminated synthetic meperidine in 1982 (Langston et al, 1983). MPTP is a mitochondrial toxicant, the oxidised form of which, MPP<sup>+</sup>, acts by inhibiting complex 1 of the mitochondrial transport chain, thus impeding energy production which results in abnormal neuronal function (Dauer and Przedborski. 2003).

Parkinson's disease occurs in both sporadic and familial forms throughout the population, and much work has been undertaken to identify genetic factors which cause the disease or contribute to an individual's susceptibility. Whilst fewer than 10% of cases are thought to be familial (Ibáñez et al, 2009), research has provided evidence of genetic factors which play a role in these cases and also in sporadic Parkinson's (Klein and Westernberger, 2012). Both autosomal dominant and recessive genes have been identified to contribute to the pathology, and four in particular have been widely investigated to elucidate their role; *SNCA*, *PINK1*, *Parkin* and *LRRK2*. The *SNCA* gene encodes for  $\alpha$ -synuclein protein, and its mechanistic effects within Parkinson's disease are not yet understood, however investigations of the other genes has provided a clearer idea of how genetic and environmental interactions may affect the disease and contribute towards its progression. Both *Parkin* and *LRRK2* genes play a role in major intracellular waste disposal systems; *Parkin* in the ubiquitin-proteasome system, and *LRRK2* in the autophagy-lysosome pathway (Schnabel, 2010). When functional, they may offer protection against other pathological contributors, through degradation and removal of proteins. Evidence indicates that *PINK1* directly recruits *Parkin* from the cytosol to mitochondria, where it becomes metabolically active; their function in a common pathway infers that defects in one will therefore affect the other, leading to the common pathology (Stephanis, 2012; Schnabel, 2010).

The *SNCA* gene is of particular interest in Parkinson's research (Klein and Westernberger, 2012; Polymeropoulos et al, 1998) as  $\alpha$ -synuclein protein is found in both familial and sporadic cases of the disease (Stephanis, 2012). Whilst this aggregated protein is a distinctive pathological hallmark in Parkinson's patients, in the form of Lewy bodies and Lewy neuritis which are found most often in the substantia nigra, its role in the disease remains undetermined (Siegel et al, 2006). Normal  $\alpha$ -synuclein is usually found in synaptic vesicles and membranes, along axons and terminals in a variety of neurons (Stephanis, 2012). *SNCA* is a gene of

autosomal dominant inheritance and its mutated forms are often found in cases of early onset Parkinson's (<50 years age of onset)(Klein and Westernberger, 2012). Several mutated forms of this gene have been linked to the diseases progression, including the A53T missense mutation, which was first identified in a large Italian-Greek family, the Contursi kindred (Recchia, 2004). In this abnormal form, a G209A substitution occurs, which alters the amino acid sequence of the protein, causing a conformational aberration which leads to intracellular aggregation of  $\alpha$ -synuclein.

As mitochondrial abnormalities have been attributed to causing Parkinson-like symptoms, exemplified by the MPTP case, investigations have been undertaken to determine whether the genetic mutations associated with Parkinson's disease have affects upon these organelles. Knott et al (2008) explain the importance of mitochondria in enabling neurons to function; they are essential for energy production,  $\text{Ca}^{2+}$  regulation, transport processes, and the release and reuptake of neurotransmitters, such as dopamine, at synapses. Neurons have a high energy demand, and require a healthy population of mitochondria to supply them with ATP, as they are unable to switch to glycolysis if oxidative phosphorylation becomes limited. Mitochondrial defects are observable in various common neurodegenerative disorders; oxidative damage is an early event in Alzheimer's disease and complex I inhibition by MPTP induces parkinsonism (Nunomura et al, 2001; Betarbet et al, 2000; Fornai et al, 2005). The *PINK1* gene, and its Parkinson's disease associated mutations, was of substantial importance in establishing a genetic link between Parkinson's disease and mitochondrial dysfunction; the identification of this genes mutation in patients provided the first evidence of a direct link between Parkinson's disease and dysfunction of a mitochondrial protein (Valente et al, 2004).

Mitochondrial dynamics (see figure 1) play a critical role in maintaining a healthy population of functioning mitochondria within cells, especially when exposed to metabolic or environmental stresses. The term encompasses the organelles fission and fusion abilities, as well as their movement processes which allow them to supply energy to cellular extensions, such as axons and dendrites (Chen and Chan, 2009; Xie and Cheng, 2012). Through fusion, the effects of stress can be mitigated by mixing the contents of partially damaged mitochondria to allow complementation of the undamaged parts in the combined organelle. Fission is the opposite of this process; it is required to divide mitochondria and to enable removal of those which are severely damaged, providing a quality control mechanism within the cell (Youle et al, 2012). Mitochondrial movement, fission and fusion are all controlled by proteins which interact with the organelles; Mfn1, Mfn2 and OPA1 are involved in fusion, Drp1 and Fis1 have been show to play roles in fission, and it is thought that secondary roles of some fusion proteins facilitate mitochondrial movement throughout the cell (Chan, 2006; Knott et al, 2008; Mecusen et al, 2006).

Recent studies have linked genetic mutations found in other forms of familial Parkinson's disease to mitochondrial damage within the pathology (Cui et al, 2010; Knott et al, 2008; Sum et al, 2006; Valente et al, 2004; Wild and Dikic, 2010). Mutations in the PTEN-induced putative kinase 1 (PINK1) gene have been demonstrated to contribute to mitochondrial deficiencies and manipulation of mitochondrial dynamics has been shown to alleviate these effects (Cui et al, 2012; Sum et al, 2006; Valente, 2004). Valente et al (2004) performed an early investigation into the effects of a PINK1 mutant (G309D) on mitochondrial function in vitro, using monkey kidney COS-7 cells and SH-SY5Y neuroblastoma cells.

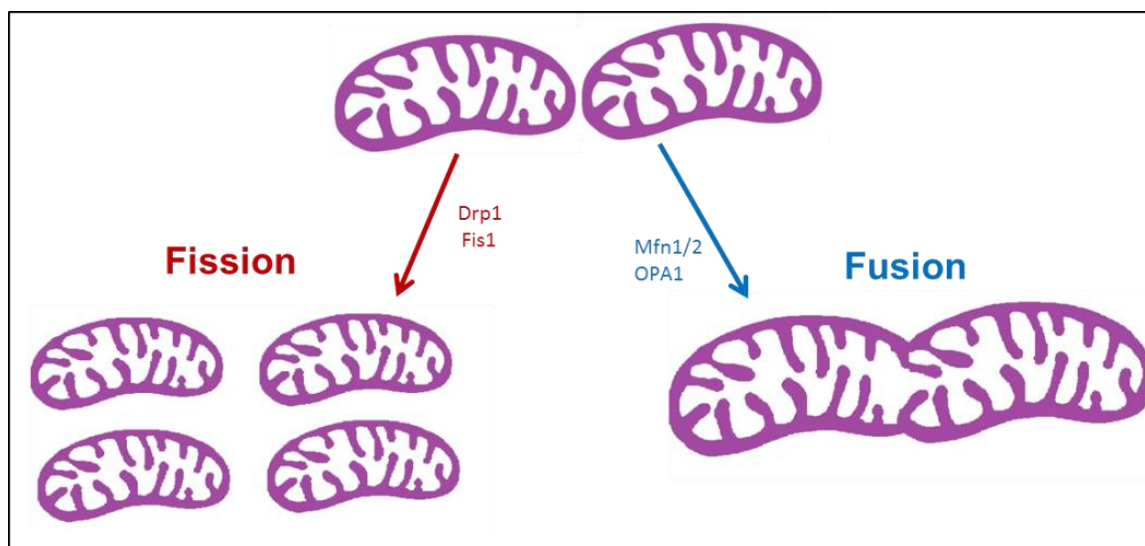

**Figure 1;** A basic mitochondrial fission/fusion diagram. Fission is the process through which new mitochondria are produced, and quality of the organelles may be checked, by facilitating the removal of damage mitochondria from the cellular network for destruction by mitophagy. Drp1 and Fis1 are two proteins involved in mitochondrial fission. Mitochondrial fusion helps to mitigate the effects of mitochondrial damage as the combination of two damaged organelles is thought to facilitate a compensatory effect, allowing survival of the fused mitochondrion, Fusion of the inner and outer mitochondrial membrane is controlled by Mfn1, Mfn2 and OPA1. (Knott et al, 2008)

Their study demonstrated that both mutant and wild type PINK1 localised to the mitochondria, and found that under normal cellular conditions there was no significant difference in the basal respiratory capacity of the cells. Following stress, induced by treatment with MG-132, the PINK1 mutant cells displayed a significant decrease in respiration from that of normal. In this study, a fluorescence-activated cell sorting based assay was used to assess mitochondrial function. In a 2006 study by Sum et al, PINK1's neuroprotective properties were demonstrated; Using SH-SY5Y neuroblastoma cells, a loss of mitochondrial membrane potential in PINK1 cells was shown when treated with neurotoxins, in comparison to normal SH-SY5Y cells. Overexpression of PINK1 followed by the same treatment demonstrated its protective effect as the loss of mitochondrial membrane potential was suppressed. Introduction of Parkinson's disease-associated PINK1 mutations G386A and G409P in their model significantly reduced PINK1 kinase activity, providing some clues into the mechanism by which PINK1 is protective. The majority of PINK1 mutations affect catalytically critical regions of the protein, which alters its function and abolishes its neuro-protective effect. Cui et al (2010) demonstrate the effect of reduced mitochondrial fission in vitro, through transfection of N27 dopaminergic neurons expressing wild type or mutant PINK1 (L347P or W437X) with dominant negative Drp1<sup>K38A</sup> or treatment with mitochondrial division inhibitor (mdivi-1). High performance liquid chromatography measurement of ATP and morphological assessment of treated and non-treated cells revealed that both Drp1<sup>K38A</sup> and mdivi-1 successfully attenuate the morphological and functional defects induced by PINK1 overexpression. This earlier study in the Tieu lab shares similarities with our current project, so similar techniques will be utilised to elucidate the pathological effects of  $\alpha$ -synuclein in a cellular Parkinson's disease model.

Current treatment of Parkinson's disease involves the administration of dopamine pre-cursors or agonists (Marieb and Hoene, 2010). Most commonly,

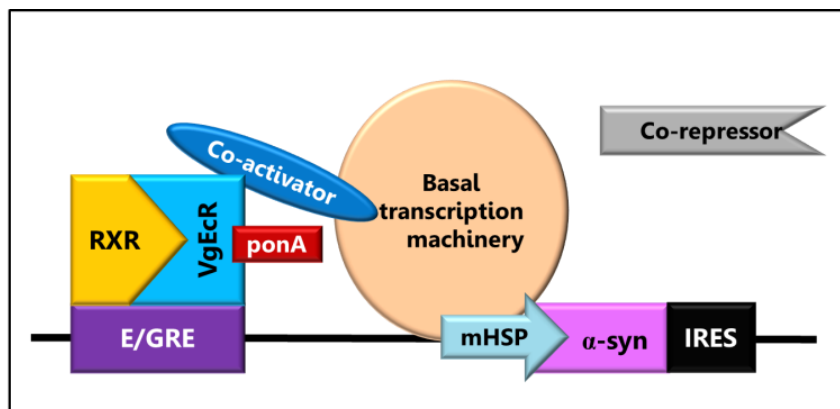

**Figure 2;** Inducible overexpression of  $\alpha$ -synuclein in rat dopaminergic N27 neuronal cells. Stable cells containing a vector that constitutively expressed the ecdysone receptor (VgEcR) and the retinoid X receptor (RXR) were generated. These cells were subsequently stably transfected with a second vector that contains the ecdysone-responsive element (E/GRE) and a multiple cloning site for the insertion of either human wild type  $\alpha$ -synuclein, mutant A53T  $\alpha$ -synuclein or an empty vector. The VgEcR-retinoid X receptor heterodimer binds to the E/GRE. In the presence of Ponasterone A, an ecdysone analogue inducer, the co-repressors are released from VgEcR, and co-activators are recruited resulting in gene activation via the minimal heat shock promoter (mHSP). IRES, internal ribosomal entry site.

Levodopa (L-dopa) is given along with DOPA-decarboxylase inhibitors, which are unable to permeate the blood brain barrier, thus specifying L-DOPA conversion into dopamine to within the brain. This causes an increase in neural dopamine levels, reducing the symptomatic presentation of the disorder (Grayson, 2010). Another treatment method is the use of dopamine agonists, which imitate dopamine's action within the brain (Smith, 2010). Whilst both of these treatments, along with several others, have proven effective at relieving the symptomatic presentation of Parkinson's disease, there are not yet any neuro-restorative or neuro-protective treatments for the disorder. No therapeutic strategy has been devised to target the mechanisms of Parkinson's disease; medicine can merely slow its progression. If science can further the understanding of what causes the pathophysiology of Parkinson's, it can be targeted to try and combat the cause of the disease, and therefore work into the mechanisms is fundamentally important in furthering therapy development.

The aim of this study was to characterise the toxicity of mutant  $\alpha$ -synuclein (Parkinson's disease-linked A53T missense mutation) on mitochondrial morphology and function in stably inducible dopaminergic N27 neuronal cells, using empty vector transfected cells as a comparative control. Characterisation of this cell model will aid future investigations, as well as demonstrating the mechanism of the disease, which may help in the development of prospective therapeutic methods.

## Materials and Methods

### Generation and culture of stable and inducible $\alpha$ -synuclein cell line

The expression of wild type and mutant A53T  $\alpha$ -synuclein in the dopaminergic 1RB<sub>3</sub>AN<sub>27</sub> (N27) neuronal cells was accomplished using The Complete Control<sup>®</sup> Inducible Mammalian Expression System (Stratagene, La Jolla, CA) as previously

described in the Tieu lab (Cui et al, 2010)(see figure 2). Wild type and mutant A53T  $\alpha$ -synuclein, and empty vector control cells were cultured in selective media specific for the transfected cells (RPMI medium containing 10% FBS, G418 [1:100] and Hygromycin B [1:250]), prior to induction of protein expression with Ponasterone A [1:100 dilution](Invitrogen™).

### **Assessment of mitochondrial morphology**

Empty vector, wild type and A53T  $\alpha$ -synuclein cells were grown on poly-L-lysine coated coverslips in 24 well plates. Following overnight growth to allow cell adjustment to growth on the coverslips, Ponasterone A [1:100 dilution](Invitrogen™) was added to the media to induce protein expression. Multiple time points post-induction were investigated for each cell line; 24 hours, 48 hours and 72 hours. Control groups for  $\alpha$ -synuclein wild type, A53T mutant and empty vector were grown for the same time points without the presence of Ponasterone A in the media. After the appropriate growth period, cells were fixed with 4% paraformaldehyde in media, and immunocytochemistry performed. Mitochondria were labelled with polyclonal rabbit Tom20 antibody (Santa Cruz Biotechnology Inc.) and  $\alpha$ -synuclein with monoclonal mouse antibody (BD Transduction Laboratories™). Coverslips were then mounted with Prolong Gold Antifade Reagent with DAPI (Invitrogen) and images captured using epifluorescence (Nikon 80i) and confocal microscopy.

### **Analysis of mitochondrial function**

Empty vector and A53T  $\alpha$ -synuclein cells were cultured in XF<sup>o</sup>24 micro-plates (Seahorse Bioscience) for 48 hours prior to induction of protein expression with Ponasterone A [1:100 dilution](Invitrogen™). Culture was continued for 24-48 hours post-induction before analysis of cellular respiration using an XF<sup>o</sup>24 Extracellular Flux Analyser (Seahorse Bioscience). Oligomycin, FCCP and a rotenone-antimycin mixture were injected sequentially to determine the respiratory capacity, coupling and non-mitochondrial function of the cells through measurement of their oxygen consumption rate (OCR). Seahorse technology avoids the use of labels which may modify cellular function to provide unaltered measurement of cellular respiratory capacity. Variable buffers were tested to determine the most effective protocol for the cell line used, in order to optimise the technique. The protocol used was adapted from that used by Affourtit's lab to account for the differences in cellular demands and growth protocols (C Affourtit and J Barlow, 2012, unpublished). Raw data from these three experiments was converted into values of respiratory capacity, coupling and non-mitochondrial respiration in Excel, and their significance analysed using a two-way ANOVA.

### **Western blot analysis of protein expression**

To complement immunocytochemistry data of protein effect upon mitochondria, western blot analysis was used to compare the levels of protein expression between wild type  $\alpha$ -synuclein and empty vector cells with established controls at variable time points. Cells cultured in T25 flasks with RPMI, 10% FBS, G418 (1:100 dilution) and Hygromycin B (1:250) had protein expression induced by Ponasterone A [1:100 dilution](Invitrogen™) addition for 6, 24, 48 or 72 hours. After the allotted growth period, cells were trypsinised, washed with PBS and centrifuged. Following removal of the supernatant, the cell pellets were frozen at -80°C until samples for all of the time points were obtained. Prior to western blot analysis of protein expression, a BCA assay (Pierce™, Thermo Scientific) determined the levels of protein in each



sample and these allowed calculation of the appropriate sample quantities to use in order to equalise the samples. The final western blots were run using a 15% resolving gel and a 4% stacking gel, with ten wells per gel. The protein ladder (Kaleidoscope, Biorad) and a positive control of recombinant  $\alpha$ -synuclein were run in the first two wells, followed by the samples and further controls;  $\alpha$ -synuclein expressing human brain sample served as another positive control. Gels ran for 90 minutes at 80V and samples were transferred to nitrocellulose gel at 100V for 30 minutes. Following probing with  $\alpha$ -synuclein and  $\beta$ -actin antibodies, the gel was developed using ECL.

## **Results**

### **Generation of stable cells with inducible expression of human wild type and mutant $\alpha$ -synuclein**

To facilitate characterisation of the role of  $\alpha$ -synuclein in Parkinson's disease, stable cell lines with inducible expression of wild-type or dominant mutant A53T  $\alpha$ -synuclein and empty vector controls were created. A53T was selected as the mutant form for investigation as it has been reported to have the greatest effect upon mitochondrial function (Kamp et al, 2010). Expression of the wild type and mutant A53T  $\alpha$ -synuclein in the dopaminergic 1RB<sub>3</sub>AN<sub>27</sub> (N27) neuronal cells was accomplished using The Complete Control<sup>®</sup> Inducible Mammalian Expression System (Stratagene, La Jolla, CA), chosen as these rat mesencephalic dopaminergic neuronal cells display tubular mitochondrial morphology, aiding the identification of abnormal, fragmented mitochondria. Wild type  $\alpha$ -synuclein was used in investigation of morphology and time dependent protein expression, however it was discounted from functional investigations of mitochondria as the mutant form have previously been reported to produce the most profound functional effects. The empty vector controls have been through the same transfection process as the  $\alpha$ -synuclein expressing cells, to account for any effects which the process may have upon cellular function.

### **Induction of mutant A53T $\alpha$ -synuclein expression alters mitochondrial morphology**

The initial step in this investigation focused on determining what effect  $\alpha$ -synuclein expression had upon mitochondrial morphology. Using polyclonal TOM20 antibody to label mitochondria, visualisation of the mitochondrial network within the cells displayed long interconnected organelles in empty vector cells (Figure 3A); the network extends throughout the length of the cell. These cells were also labelled with monoclonal  $\alpha$ -synuclein antibody to ensure that no expression of the protein occurred. In mutant A53T  $\alpha$ -synuclein-expressing cells, fragmentation of the mitochondrial network is visible from 24 hours post-induction with Ponasterone A (Figure 4). Un-induced A53T  $\alpha$ -synuclein cells can be used as a comparison to demonstrate the specificity of protein expression following induction of protein expression, as no  $\alpha$ -synuclein is detectable in these cells (Figure 3C). Induced mutant cells display evidence of fragmentation of the mitochondrial network after 72 hours, apparent in cells with obvious  $\alpha$ -synuclein expression and also in cells close by (Figure 3D). In the empty vector controls, the mitochondrial networks remain intact, in both the un-induced and induced groups, at all three investigated time points. Clarification of whether mitochondrial fragmentation increases in the induced

A53T  $\alpha$ -synuclein group as time progresses has not been quantified, however qualitative observation would suggest that this is the case.

### Expression of A53T mutant $\alpha$ -synuclein protein has no effect on cellular respiratory capacity

Analysis of cellular oxygen consumption rate as an indication of cellular respiratory capacity and mitochondrial function of the N27 cell lines using a Seahorse XF<sup>e</sup> 24 analyser (*Seahorse Bioscience*) revealed no significant differences in the data from multiple experiments at two different time points post-induction of protein expression by Ponasterone A. When the data was analysed using a two way ANOVA (general

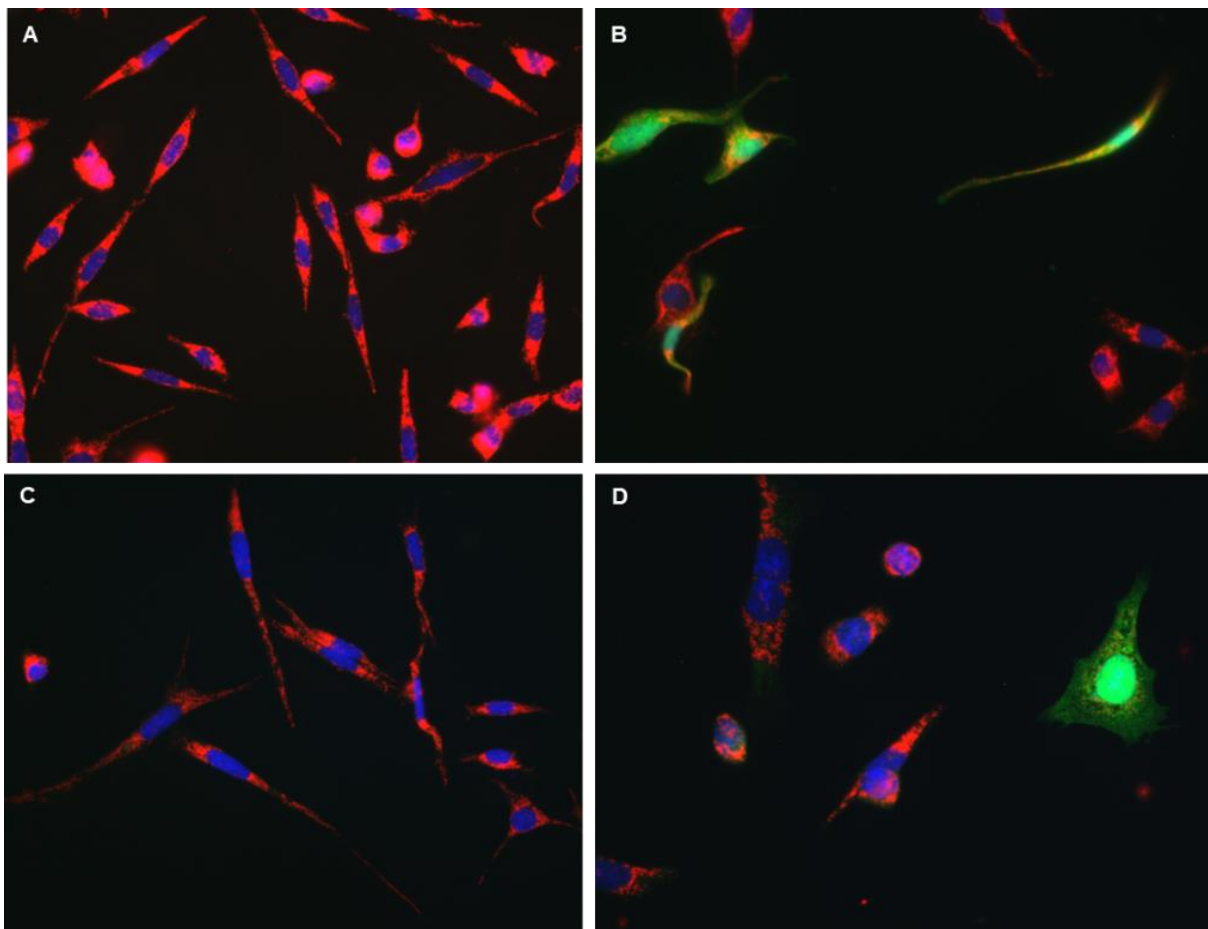

**Figure 3;** Epifluorescence images captured on a Nikon 80i. (A) Un-induced empty vector cells after 48 hours coverslip growth; long tubular mitochondrial networks are visible extending throughout the cells (B) Wild-type  $\alpha$ -synuclein cells following 48 hour induction with Ponasterone A display similar expression levels to the mutant A53T cells (C) Uninduced A53T  $\alpha$ -synuclein after 72 hours of growth; mitochondria display similar morphology to that of the empty vector cells, with long extension throughout the cell projections (D) Induced A53T  $\alpha$ -synuclein cells 72 hours post-induction with Ponasterone A; fragmentation of mitochondrial and formation of punctate morphology is evident

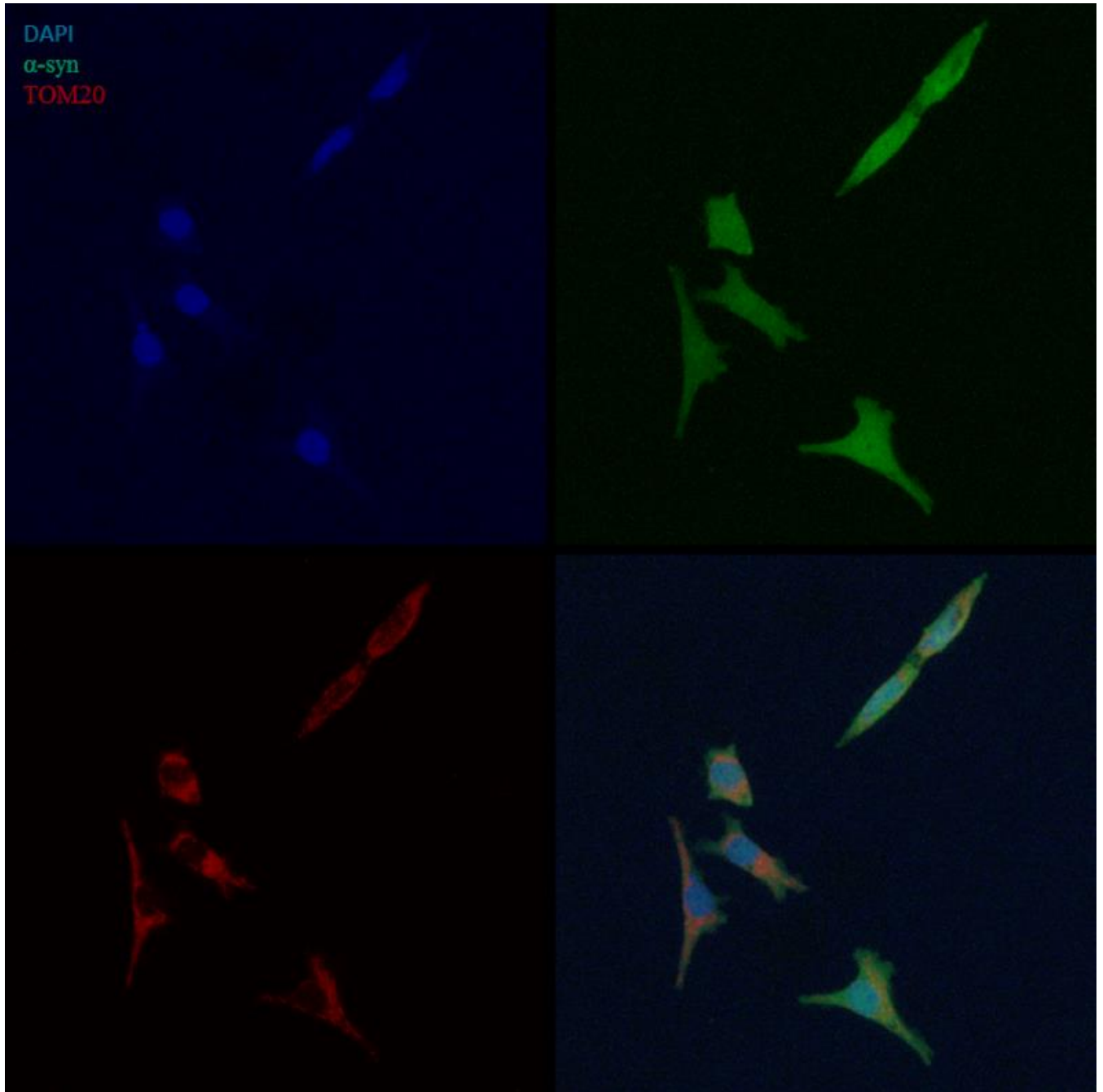
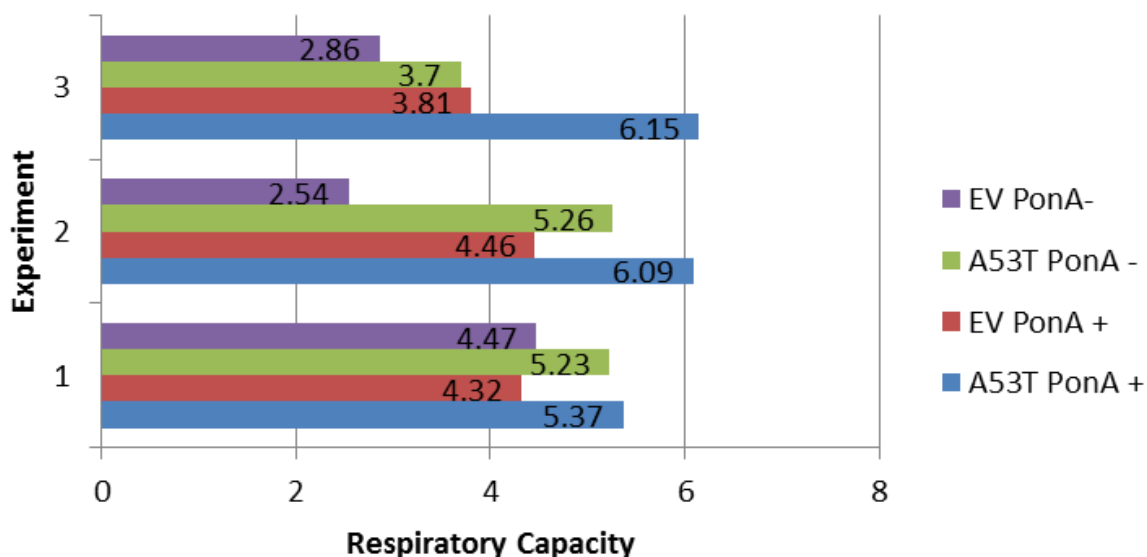

**Figure 4;** A53T  $\alpha$ -synuclein mutant N27 cells following 24 hours protein expression, induced by Ponasterone A. This confocal image allows differentiation between the labels, and the beginnings of mitochondrial fragmentation are visible in the TOM20-only panel. The high level of protein expression is clear and each cell is individually identifiable.

linear model) no significant variance is detectable in the respiratory capacity of the cells between the two time points, 24 and 48 hours ( $p=0.659$ ), between the cell lines and treatment groups ( $p=0.080$ ) or when all three factors are considered in relation to each other ( $p=0.802$ ). These results indicate no change in the respiratory capacity of the cells in relation to expression of mutant  $\alpha$ -synuclein protein, however the data is derived from only three individual experiments, which limits the strength of any conclusions; further work to clarify the accuracy of the results is required. Figure 5 displays the mean respiratory capacity from three comparable experiments; an induced and non-induced group for both A53T  $\alpha$ -synuclein mutant and empty vector cells provided a total of four treatment conditions for comparison in each of the tests. The differences in the respiratory capacity between the cell lines and treatments may be attributable to variance between the growth rates of the cells between the wells.

### Variance of wild type $\alpha$ -synuclein expression in a time course study

Detection and comparison of  $\alpha$ -synuclein using western blotting demonstrated that the level of protein increases the longer the cells are exposed to Ponasterone A in the media (Figure 6). Comparison of the 6 hour and 72 hour post-induction time points allows observation of a clear difference in protein levels. Alpha-synuclein is only present in the induced samples and the two positive controls; recombinant  $\alpha$ -synuclein and human brain sample. B-actin is present in all of the samples, including the empty vector control and un-transfected N27 cells, which indicates that the lack of  $\alpha$ -synuclein detected in these groups is due to a lack of expression, rather than as a failure to transfer protein in the analysis. Western blot results have only been generated for the wild-type  $\alpha$ -synuclein samples, so further tests with mutant samples are required for comparison to the functional investigation. The results of



**Figure 5;** Comparison of the cellular respiratory capacity of two cell types, each with an induced and non-induced group, at two time points over three experiments. (1,2) Cells treated with Ponasterone A for 24 hours prior to measurements of their oxygen consumption rate. (3) Cells treated with Ponasterone A for 48 hours prior to recording of their oxygen consumption rate.

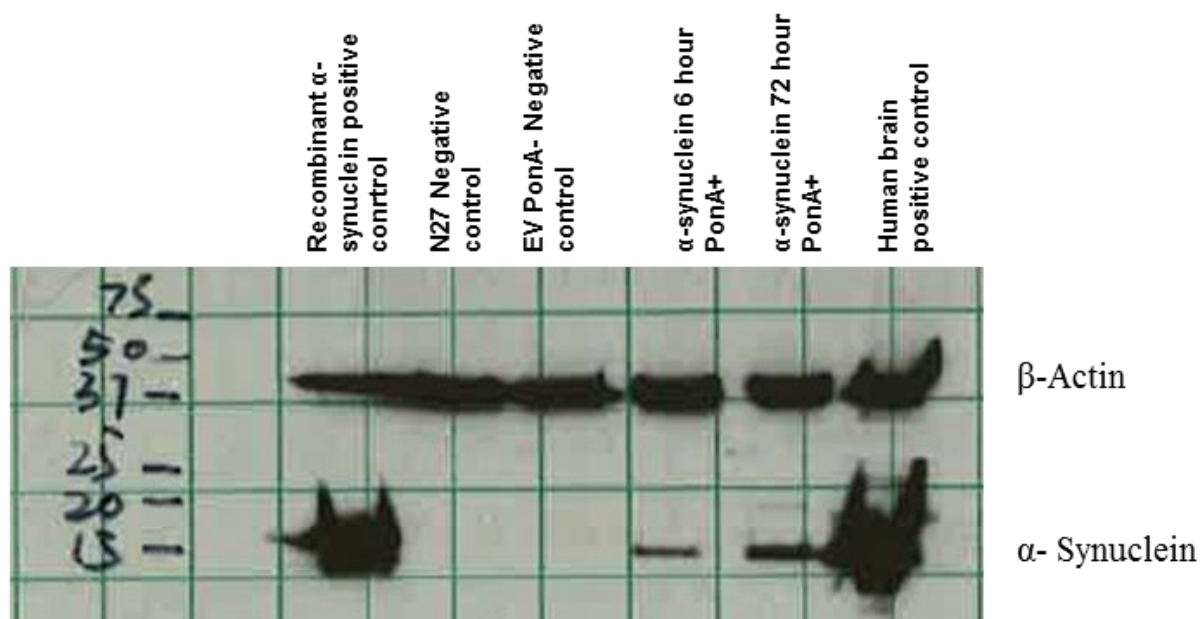

**Figure 6;** Western blot film. Two negative and two positive controls were compared against the levels of  $\alpha$ -synuclein at the 6 hour and 72 hour post-induction time points. No  $\alpha$ -synuclein is detected in either of the negative control groups, and strong signal is evident in the two positive controls. A clear difference in  $\alpha$ -synuclein is visible between the 6 hour and 72 hour time point, demonstrating that the level of protein expression increases with time following induction with Ponasterone A. [ $\alpha$ -synuclein primary antibody – 1:1000 dilution,  $\beta$ -actin primary antibody – 1:10,000 dilution, Mouse secondary antibody – 1:10,000 dilution] Developed in ECL and exposed to nitrocellulose membrane for three minutes.

this blot are promising and thus an increase in A53T  $\alpha$ -synuclein expression over time is expected also.

## Discussion

In this study, evidence of morphological changes in the mitochondrial network induced by mutant A53T  $\alpha$ -synuclein is demonstrated, the effectiveness of this cell model is confirmed, as is its applicableness to multiple investigative methods. The necessity to fully optimise protocols when working with these cells using new techniques has been shown, and through further work it will be possible to extend this investigation to accurately determine the functional consequences of mutant protein expression. Once understanding of the proteins effects on mitochondria is confirmed, progression of the study to include approaches to neutralise or inhibit the effects of  $\alpha$ -synuclein upon dopaminergic neuronal cells, providing a novel therapeutic target, may be possible.

The immunocytochemistry and western blot results, whilst non-quantitative, suggest experimental provision of evidence showing the detrimental effect which mutant A53T  $\alpha$ -synuclein has upon mitochondrial morphology, increasing the levels of network fragmentation as time, and subsequently protein levels, increase. A53T  $\alpha$ -synuclein expression leads to the fragmentation of normal long, tubular mitochondria and the formation of small, punctate mitochondria. In a 2012 study, Gui et al demonstrated how the induction of mitochondrial fragmentation is caused by  $\alpha$ -synuclein expression in mammalian cells, including neurons, which is concurrent

with our findings. The western blot data demonstrates an increase  $\alpha$ -synuclein levels over time in the wild-type protein, but no data for the mutant protein has yet been obtained. The higher inducibility of the A53T cell line allows it to be suggested that a similar progression of protein accumulation would also occur in the mutant cells, however this requires confirmation. As the immunocytochemistry examined the effect of mutant A53T  $\alpha$ -synuclein on the mitochondrial morphology of these dopaminergic neuronal cells, to establish whether the increased fragmentation over time is due to increased protein expression, western blots using mutant samples are required to confirm that the fragmentation is time, and protein level, dependent. Evidence of increased expression of mutant A53T  $\alpha$ -synuclein over time could also be beneficial in explaining functional analyses of mitochondrial function by tying these factors together so that a causal link may be further explored.

Whilst the mechanism by which fragmentation of the mitochondrial network occurs has not been tested in this study, recent publications have demonstrated the ability of  $\alpha$ -synuclein, both wild type and mutant forms, to translocate to the mitochondria where interactions with the outer membrane or alteration of the fission/fusion protein function may induce fragmentation (Kamp, 2010; Knott, 2008; Shavali, 2008; Sulzer, 2010). Interaction of  $\alpha$ -synuclein with the outer mitochondrial membrane following specific translocation to that organelle is recurrent in the literature (Knott, 2008; Shavali, 2008), and specific membrane proteins which are highly expressed in mitochondrial membranes have been suggested as the target which drives this specific protein localisation (Nakamura, 2011). It has been proposed that a direct interaction between the protein and the mitochondrial membranes contribute to the mechanism through which the fragmentation is effected, in a Drp1-independent manner, as data suggested an absence of relationship between fission proteins and  $\alpha$ -synuclein (Nakamura, 2011), however this is opposed by other work which ties fission/fusion protein interactions into the fragmentation process (Gui et al, 2012).

Whilst no significance was recognised when considering the functional effects of  $\alpha$ -synuclein on mitochondria, the results should not be discounted as useless. It may be that the data is unrepresentative, due to factors which were still being tested when the results were obtained, such as the best buffer to use, or the most appropriate oligomycin concentration, as the technique is new to these cells and alteration of an established method was required to create an illustrative study of mitochondrial function. As only two time points were considered, in three experiments, when testing mitochondrial function it is possible that the protein had not yet taken effect and repeating the experiment at a later time point could reveal the functional effects of  $\alpha$ -synuclein expression in our cell model. In some studies, no change in mitochondrial function is detectable until the 48 hour time point, post-induction/treatment with  $\alpha$ -synuclein (Nakamura, 2011). Although functional impairment of mitochondria has been shown in studies using both wild type and mutant A53T  $\alpha$ -synuclein (Devi, 2008; Kamp, 2010; Nakamura, 2011) others report differing findings; Orth et al (2003), Shavali et al (2008) and Wu et al (2009) all detected no direct influence of  $\alpha$ -synuclein expression upon mitochondrial function, but detailed that the protein may still play a role in susceptibility to mitochondrial damage by enhancing the effect of known toxicants, such as MPTP and rotenone, to produce toxic effects at sub-toxic levels. Dauer et al (2002) produced similar results, establishing in an animal model that absence of  $\alpha$ -synuclein provided resistance against the parkinsonian neurotoxin MPTP. The true effects of  $\alpha$ -synuclein expression upon the functional capacity of mitochondria remains to be fully

corroborated, though it seems clear from our study, as well as in others, that any modifications of mitochondrial function occur after morphological changes have been induced (Nakamura, 2011). This may be due to functional complementation, in which the remaining healthy mitochondria within the cells may increase their activity to combat the loss of function in damaged organelles, which could delay the observation of respiratory dysfunction. Many studies link  $\alpha$ -synuclein to mitochondrial complex 1 interactions and inhibition (Chinta et al, 2010; Devi et al, 2008; Loeb et al, 2010) so perhaps more specific investigation of how the protein affects mitochondria would also be of value.

In summary, this study successfully established the effect of A53T mutant  $\alpha$ -synuclein on the mitochondrial morphology of inducible dopaminergic neuronal cells, however further work is required to ascertain the role of this protein in alteration of cellular respiration and mitochondrial function. Additional work to optimise the method used for measuring mitochondrial function will benefit future investigation and provide more reliable results. Understanding of the mechanistic effects of  $\alpha$ -synuclein protein may lead on to targeting of these mechanisms in order to combat the progression and presentation of Parkinson's disease.

## References

- Betarbet R, Sherer TB, MacKenzie G, Garcia-Osuna M, Panov AV, Greenamyre JT (2001) Chronic systemic pesticide exposure reproduces features of Parkinson's disease. *Nature Neuroscience*, 3; 1301-1306
- Campenhausen SV, Bornshien B, Wick R, Bötzel K, Sampaio C, Poewe W, Oertel W, Siebert U, Berger K, Dodel R (2005) Prevalence and incidence of Parkinson's disease in Europe. *European Neuropsychopharmacology*, 15; 473-490
- Chan DC (2006) Dissecting mitochondrial fusion. *Developmental cell*, 11; 592-594
- Chen H and Chan DC (2009) Mitochondrial dynamics – fusion, fission, movement and mitophagy – in neurodegenerative diseases. *Human Molecular Genetics*, 18; 169-176
- Chinta SJ, Mallajosyula JK, Rane A, Anderson JK (2010) Mitochondrial alpha-synuclein accumulation impairs complex I function in dopaminergic neurons and results in increased mitophagy in vivo. *Neuroscience Letters*, 486; 235-239
- Cui M, Tang X, Christian WV, Yoon Y, Tieu K (2010) Perturbations in mitochondrial dynamics induced by human mutant PINK1 can be rescued by the mitochondrial division inhibitor mdivi-1. *The Journal of Biological Chemistry*, 285; 11740-11752
- Dauer W, Kholodilov N, Vila M, Trillat AC, Goodchild R, Larsen KE, Staal R, Tieu K, Schmitz Y, Yuan CA, Rocha M, Jackson-Lewis V, Hersch S, Sulzer D, Przedborski S, Burke R, Hen R (2002) Resistance of alpha-synuclein null mice to the parkinsonian neurotoxin MPTP. *Proceedings of the National Academy of Sciences of the United States of America*, 99; 14524-15429
- Dauer W and Przedborski S (2003) Parkinson's disease: mechanisms and methods. *Neuron*, 39; 889-909



Devi L, Raghavendra V, Prabhu BM, Avadhani NG, Anandatheeravarada HK (2008) Mitochondrial import and accumulation of alpha-synuclein impair complex 1 in human dopaminergic neuronal cultures and Parkinson disease brain. *The Journal of Biological Chemistry*, 283; 9089-9100

Fornai F, Schlüter OM, Lenzi P, Gesi M, Ruffoli R, Ferrucci M, Lazzeri G, Busceti CL, Pontarelli F, Battaglia G, Pellegrini A, Nicoletti F, Ruggieri S, Paparelli A, Südhof TC (2005) Parkinson-like syndrome induced by continuous MPTP infusion: convergent roles of ubiquitin-proteasome system and  $\alpha$ -synuclein. *Proceedings of the National Academy of Sciences of the United States of America*, 102; 3413-3418

Grayson M (2010) Parkinson's Disease. *Nature*, 466

Gui YX, Wang XY, Kang WY, Zhang YJ, Zhang Y, Zhou Y, Quinn TJ, Liu J, Chen SD (2012) Extracellular signal-regulated kinase is involved in alpha-synuclein-induced mitochondrial dynamic disorders by regulating dynamin-like protein 1. *Neurobiology of Aging*, 33; 2841-2854

Ibáñez P, Lasage S, Janin S, Lohmann E, Durif, Destée A, Bonnet AM, Brefel-Coubon C, Heath S, Zelenoika D, Agid Y, Dürr A, Brice A (2009)  $\alpha$ -synuclein gene rearrangements in dominantly inherited Parkinsonism: frequency, phenotype and mechanisms. *Archives of Neurology*, 66; 102-108

Kamp F, Exner N, Lutz AK, Wender N, Hegermann J, Brunner B, Nuscher B, Bartels T, Giese A, Beyer K, Einner S, Wiklhofer KF, Hasiss C (2010) Inhibition of mitochondrial fission by  $\alpha$ -synuclein is rescued by PINK1, Parkin and DJ-1. *The EMBO Journal*, 29; 3571-3587

Klein C and Westernberger A (2012) *Genetics of Parkinson's Disease*. Cold Springs Harbour Laboratory Press, 2

Knott A, Perkins G, Schwarzenbacher R, Bossy-Wetzel E (2008) Mitochondrial fragmentation in neurodegeneration. *Nature Reviews Neuroscience*, 9; 505-516

Langston JW, Ballard P, Tetrud JW, Irwin I (1983) Chronic parkinsonism in humans due to a product of meperidine-analog synthesis. *Science*, 25; 979-980

Loeb V, Yakunin E, Saada A, Sharon R (2010) The transgenic overexpression of alpha-synuclein and not its related pathology associates with complex I inhibition. *The Journal of Biological Chemistry*, 285; 7334-7343

Marieb EN and Hoene K (2010) *Human Anatomy and Physiology*, 8<sup>th</sup> Edition, Benjamin Cummings

Mecusen S, DeVay R, Block J, Cassidy-Stone A, Wayson S, McCaffery JM, Numari J (2006) Mitochondrial inner-membrane fusion and crista maintenance requires the dynamin-related GTPase Mgm1. *Cell*, 127; 383-395



Nakamura K, Nemani VM, Azarbal F, Sklbinski G, Levy JM, Egami K, Muniskina L, Zhang J, Garcher B, Wakabayashi J, Sesaki H, Cheng Y, Finkbeiner S, Nussbaum RL, Masliah E, Edwards RH (2011) Direct membrane association drives mitochondrial fission by the Parkinson disease-associated protein  $\alpha$ -synuclein. *The Journal of Biological Chemistry*, 286; 20710-20726

Nunomura A, Perry G, Aliev G, Hirai K, Takada A, Balraj EK, Jones PK, Ghanbari H, Wataya T, Shimohama S, Chiba S, Atwood CS, Peterson RB, Smith MA (2001) Oxidative damage is the earliest event in Alzheimer's disease. *Journal of Neuropathology and Experimental Neurology*, 60; 759-767

Orth M, Tabrizi SJ, Schapira AHV, Cooper JM (2003)  $\alpha$ -synuclein expression in Hek293 cells enhances the mitochondrial sensitivity to rotenone. *Neuroscience Letters*, 351; 29-32

Polymeropoulos MH (1998) Autosomal dominant Parkinson's disease and alpha-synuclein. *Annals of Neurology*, 44; 63-64

Recchia A, Debetto P, Negro A, Guidolin D, Skaper SD, Giusti P (2004) Alpha-synuclein and Parkinson's disease. *The Journal of the Federation of American Societies for Experimental Biology*, 18; 617-626

Schnabel J (2010) Secrets of the shaking palsy. *Nature*, 466

Shavali S, Brown-Borg HM, Ebadi M, Porter J (2008) Mitochondrial localisation of alpha-synuclein protein in alpha-synuclein overexpressing cells. *Neuroscience Letters*, 439; 125-128

Siegel GJ, Albers RW, Brady ST, Price DL (2006) *Basic Neurochemistry; Molecular, Cellular and Medical Aspects*, ELSEVIER

Smith K (2010) Treatment Frontiers. *Nature*, 466

Stephanis L (2012)  $\alpha$ -synuclein in Parkinson's Disease. Cold Springs Harbour Laboratory Press

Sulzer D (2010) Clues to how alpha-synuclein damages neurons in Parkinson's disease. *Movement Disorders*, 25; s27-s31

Sum CH, Lio DSS, Mok SS, Masters CL, Hill AF, Culvenor JG, Cheng HC (2006) C-terminal truncation and Parkinson's disease-associated mutations down-regulate the protein serine/threonine kinase activity of PTEN-induced kinase-1. *Human Molecular Genetics*, 15; 3251-3262

Valente EM, Abou-Sleiman PM, Caputo V, Muqit MMK, Harvey K, Gispert S, Ali Z, Turco DD, Bentivoglio AR, Healy DG, Albanese A, Nussbaum R, González-Maldonado R, Deller T, Salvi S, Cortelli P, Gilks WP, Latchman DS, Harvey RJ, Dallapiccola B, Auburger G, Wood NW (2004) Hereditary Early-Onset Parkinson's Disease Caused by Mutations in PINK1. *Science*, 304; 1158-1160

Valente EM, Salvi S, Ialongo T, Marongui R, Elia AE, Caputo V, Romito L, Albanese A, Dallapiccola B, Bentivoglio AR (2004) PINK1 mutations are associated with sporadic early-onset Parkinsonism. *Annals of Neurology*, 56; 336-341

Wild P and Dikic I (2010) Mitochondria get a Parkin' ticket. *Nature Cell Biology*, 12; 104-106

Wu F, Poon WS, Lu G, Wang A, Meng H, Feng L, Li Z, Liu S (2009)  $\alpha$ -synuclein knockdown attenuates MPP<sup>+</sup>-induced mitochondrial dysfunction of SHSY5Y cells. *Brain Research*, 1292; 173-179

Xie W and Cheng KKK (2012) Alpha-synuclein impairs normal dynamics of mitochondria in cell and animal models of Parkinson's disease. *Journal of Neurochemistry*, 122; 404-414

Youle RJ and van der Bliek AM (2012) Mitochondrial fission, fusion and stress. *Science*, 337; 1062-1065