

2017-04

Signals of opportunity geolocation methods for urban and indoor environments

Mansfield, TO

<http://hdl.handle.net/10026.1/9887>

10.1007/s12243-016-0559-y

Annals of Telecommunications

Springer Science and Business Media LLC

All content in PEARL is protected by copyright law. Author manuscripts are made available in accordance with publisher policies. Please cite only the published version using the details provided on the item record or document. In the absence of an open licence (e.g. Creative Commons), permissions for further reuse of content should be sought from the publisher or author.

Signals of Opportunity Geolocation Methods for Urban and Indoor Environments.

T. O. Mansfield, B. V. Ghita, M. A. Ambroze

School of Computing and Mathematics, Plymouth University, Plymouth, United Kingdom.

Corresponding Author:

Tom Mansfield.

e-mail: thomas.mansfield@plymouth.ac.uk

tel: +44 (0) 7855 615177

The total number of words of the manuscript, including entire text from title page to figure legends: **5636**

The number of words of the abstract: **222**

The number of figures: **13**

The number of tables: **3**

1 Abstract

Motivated by the geolocation requirements of future mobile network applications such as portable internet of things (IoT) devices and automated airborne drone systems, this paper aims to provide techniques for improving device geolocation estimates in urban and indoor locations. In these applications low size, weight and power are vital design constraints. This paper proposes methods for improving the geolocation estimate available to a system in indoor and urban environments without the need for addition sensing or transmitting hardware.

This paper proposes novel system application techniques that enable the integration of signals of opportunity, providing a robust geolocation estimate without any additional hardware. The proposed method utilizes a sinusoidal Kalman filter architecture to analyse raw radio frequency (RF) signals that surround a system in urban and indoor environments. The introduced techniques efficiently analyse the raw RF data from any signal of opportunity and combine it with higher level geolocation sensors to provide an improved geolocation estimate.

The improvements achieved by the system in a range of environments have been simulated, analysed and compared to the results obtained using the prior art. These improvements have been further validated and benchmarked by hardware test. The results obtained provide evidence that the efficient use of signals of opportunity coupled with common navigation sensors can provide a robust and reliable geolocation system in indoor and urban environments.

Keywords:

Signals of opportunity, Kalman filtering, radio navigation and geolocation.

2 Introduction

Distributed networks of mobile and autonomous devices are likely to become increasingly common as the expected wide-spread adoption of both internet of things (IoT) and autonomous mobile robotic systems continues. As people spend approximately 90% of their time indoors [1], these systems will be predominantly located in indoor and urban environments. The indoor environment is likely to become crowded with large numbers of portable, low power, small size and wirelessly connected devices. The increasingly busy radio spectrum is expected to be filled with wireless communications from vast numbers of transmitting devices. While this increasingly congested RF spectrum is a concern for many system designers, it does provide a potentially valuable resource for an accurate device geolocation estimate. Geolocation estimates are vital to many system designers for two main reasons; the first is to enable devices to navigate their environment. The second benefit, particularly in IoT applications, is to be able to tag any generated data with a geographical location. This commonly increases the value of the information that can be gained from the vast array of data produced.

Global navigation satellite systems (GNSS) and low cost inertial navigation systems (INS) are commonly used to provide geolocation estimates. While significant work has been carried out to closely couple GPS and INS systems to mitigate their respective error drivers, these coupled systems are unable to provide accurate geolocation estimates in urban and indoor environments where GPS updates may be unavailable for extended periods of time. A review of current research has revealed an opportunity to couple data link RF signal analysis into the INS system, allowing the rich RF resource found in urban and indoor environments to maintain geolocation estimates where existing systems encounter their greatest errors.

This paper presents a set of novel techniques aiming to improve the accuracy of geolocation estimates for a wide range of systems. A key principle of the proposed techniques is the ability to monitor the phase estimate of surrounding RF signals to provide a ranging estimate from the transmitter. A sinusoidal Kalman filter is proposed that allows an accurate, low latency and low noise phase estimate to be maintained by the system. The resulting ranging estimation does not drift with time and lends itself to close and ultra-close coupling with INS and other system level geolocation systems, techniques for which are also presented in this paper.

The proposed methods are analysed and compared to existing methods through simulation. The obtained simulation results are further validated with a set of practical tests using data link devices typical to proposed IoT and autonomous mobile systems. The results demonstrate that, with even limited prior knowledge of the wireless data link environment, an accurate geolocation estimate is maintained for prolonged periods in urban environments.

Section 3 discusses existing system capabilities. Section 4 discusses the proposed system implementation. Section 5 presents simulation and test results. Section 6 discusses the key findings and conclusions. Further work is proposed in section **Error! Reference source not found..**

3 Current Geolocation Solutions

GNSS systems, such as the global positioning system (GPS), are commonplace in cars, mobile phones and a wide range of timing systems. All applications suffer the same significant limitation: current receivers are not sensitive enough and transmissions are not strong enough to operate the system in indoor environments. Even in urban environments such as city centres, GNSS systems frequently provide poor coverage due to the limited line of sight from the satellites to users at ground level when surrounded by tall buildings [2].

An alternative form of geolocation, not requiring an external input, is to use an INS to provide a dead reckoning estimate. INS systems provide information about changes in velocity or angular rate, allowing a user to calculate their position relative to a known starting point. The major drawback of this approach is that the dead reckoning technique integrates errors over time, causing the users calculated position to drift with respect to their actual position. Many grades of INS are available, with differing rates of drift related to the INS's accelerometer and gyro biases during operation. Small, low power systems often have larger biases which cannot be calibrated out for a particular measurement [3].

Coupled IMU and GNSS systems apply the input from both systems into a navigation filter, such as a Kalman filter [4]. Coupled systems have been developed to use the potentially intermittent GNSS system to remove the integration errors accumulated in the continually available IMU data [5]. As detailed in Figure 1, the provision of an externally generated ranging estimate allows the multiplication of the two probability distributions to provide an improved geolocation estimate.

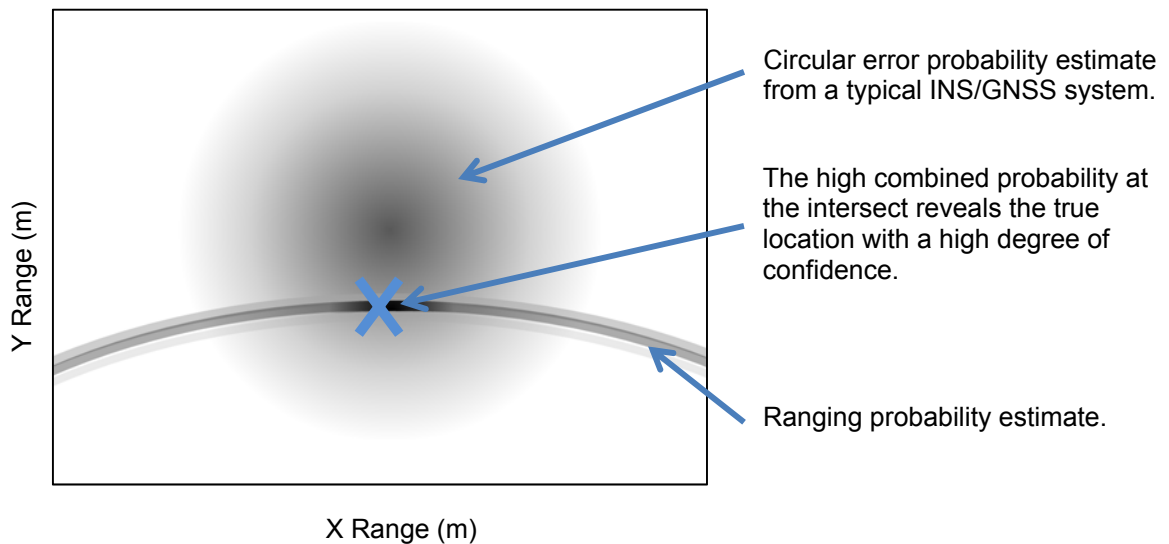

Figure 1 – Geolocation example optimised with the addition of a ranging estimation.

Closer coupling through an extended Kalman filter allows benefits to both the IMU by removing bias errors and the GNSS system by allowing an improved ability to track weak signals [6]. Research has also been carried out to enable extended Kalman filters to carry out feature recognition that, if compared to a known map, allows the Kalman filter to recognise features and objects in a mapped environment. Upon the recognition of a known feature, an external ranging estimate can be calculated. This allows both an improved location estimate and the ability to calculate and remove errors from other system sensors [7][8].

Recent research has been carried out on the ability to use existing RF signals to provide a feature recognition, with proposed solutions commonly referred to as signals of opportunity systems. System applications use signal strength fingerprinting [9], message content [10] or message flight time [11][12] to derive geolocation data from the RF signals of opportunity. These systems each have their own limitations; however the need for prior signal mapping information and poor performance in multipath environments [13][14] are limitations in all systems [15].

Estimating the phase in signals of navigation has also been proposed [16]. This technique has produced very encouraging results in low multipath environments with errors of less than 2 meters achieved in low latency systems; however, as with other techniques, a vulnerability to multipath interference severely limits its accuracy in indoor and urban environments. While work has been carried out to mitigate this vulnerability with multiple RF channels at separated frequencies [17], no solution has been found that allows the system to operate in multipath while retaining the ability for the system to work on low latency mobile systems.

Following analysis of currently available techniques, geolocation error estimates have been identified for an automated system in a dense urban environment and presented in Table 1.

Table 1 - Estimated geolocation accuracy of existing systems in a dense urban environment.

Technique	Typical Error (3 σ) (m)	Notes
WiFi SLAM ^[9]	10	Prior knowledge of 3 rd party infrastructure required.
Coupled signal of opportunity ^[13]	20	The most widely adopted technique in current research if no environmental prior knowledge is available.
Phase Estimation ^[16]	30	Single multipath source discussed. A lower level of accuracy is anticipated in urban and indoor environments.
GNSS ^[1]	40	Not available indoors.
INS ^[3]	100	Accuracy related to operational time due to integration of error.
ToA Estimation ^[13]	300	Quoted performance is only for 'mid-urban' environments. Dense urban likely to be worse.

4 Proposed System Development

Current geolocation solutions provide good geolocation accuracy in areas of low multipath interference; this is not possible in areas of multipath such as indoor and urban environments. This paper introduces a novel method for utilising existing RF sources in order to produce a more accurate ranging geolocation estimate in multipath environments.

The proposed technique mitigates the effects of multipath by using a sinusoidal Kalman filter to track the received RF signal. This filter maintains an estimate of the expected signal phase and uses the raw RF data as a measurement input. Using a Kalman filter to maintain the latest measurements, estimates and covariance's provides significant robustness against multipath effects, which tend to be temporary in mobile systems, while still allowing low latency feature recognition.

The filter is designed to update the ranging estimate at each filter iteration. The Kalman filter will be created in two stages, one to predict the phase at the next step and a second to record data and combine it with the estimation. Matrices are created to maintain state within the Kalman filter as well as pass information into and out of the Kalman filter. The proposed implementations of these matrices are described in equations 1 to 6.

The Φ matrix maintains the translation matrix for a sinusoidal system.

$$\Phi = \begin{bmatrix} \cos(\omega\tau) & \frac{\sin(\omega\tau)}{\omega} \\ -\omega\sin(\omega\tau) & \cos(\omega\tau) \end{bmatrix} \quad (1)$$

The P matrix maintains the initial state covariance. As the location of the first reading is unknown, the following P matrix is typically applied.

$$P = \begin{bmatrix} 1e^6 & 0 \\ 0 & 1e^6 \end{bmatrix} \quad (2)$$

The measurement noise is represented in the Q matrix.

$$Q = \begin{bmatrix} 1e^{-4} & 1e^{-4} \\ 1e^{-4} & 1e^{-4} \end{bmatrix} \quad (3)$$

The system noise is represented in the R matrix.

$$R = [1e^{-4}] \quad (4)$$

And the measurement matrices are represented by the H and I matrices.

$$H = [1 \ 0] \quad (5)$$

$$I = \begin{bmatrix} 1 & 0 \\ 0 & 1 \end{bmatrix} \quad (6)$$

The estimation step is completed by carrying out the Riccati equations [18] as described below. The estimation step is carried out for each filter iteration:

$$M = \Phi^*P^*\Phi' + Q \quad (7)$$

$$H_{\text{mtrinv}} = (H^*M^*H' + R)^{-1} \quad (8)$$

$$K = M^*H'^*H_{\text{mtrinv}} \quad (9)$$

$$K_h = K^*H \quad (10)$$

$$P = I - K_h^*M \quad (11)$$

Following the estimation for the current filter step, the measurement can be made and combined into the estimated location using the maintained Kalman gain, K . Again the measurement stage, shown in equations 12 to 15, is run at each iteration of the Kalman filter.

$$x_{hold} = x_h \quad (12)$$

$$r = \frac{X_s - X_h * \cos(\omega\tau) - \sin(\omega\tau) * x_{dh}}{\omega} \quad (13)$$

$$x_h = \frac{\cos(\omega\tau) * x_h + x_{dh} * \sin(\omega\tau)}{\omega + K_{(1,1)} * r} \quad (14)$$

$$x_{dh} = -\omega \sin(\omega\tau) * x_{hold} + x_{dh} * \cos(\omega\tau) + K_{(2,1)} * r \quad (15)$$

This initial Kalman filter provides the coupling from an RF source to the resulting range estimate as shown in Figure 2.

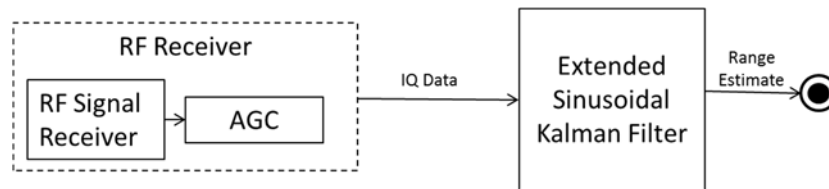

Figure 2 – Basic system configuration.

This initial implementation will provide a ranging estimation from an RF source that is resilient to the signal interference common in indoor and urban environments. The use of a sinusoidal Kalman filter also allows the system to have low latency, resulting in a minimised risk of drift due to phase cycle slip. The lack of estimate drift over time makes the resulting ranging estimate an ideal signal to be coupled to higher level INS based navigation systems. The use of a sinusoidal Kalman filter offers the opportunity for the proposed technique to become the core of a complete navigation system, with any other available navigation systems coupling directly to enhance the accuracy of each subsystem. This paper will continue to present a series of methods for efficiently integrating other navigation sensors into a closely coupled system. Figure 3 shows the three stages of system architecture required for coupled and closely coupled navigation system integration as well as control data link data decoding. The complete system has the sinusoidal Kalman filter at its core, maximising the information that can be obtained from the raw RF data.

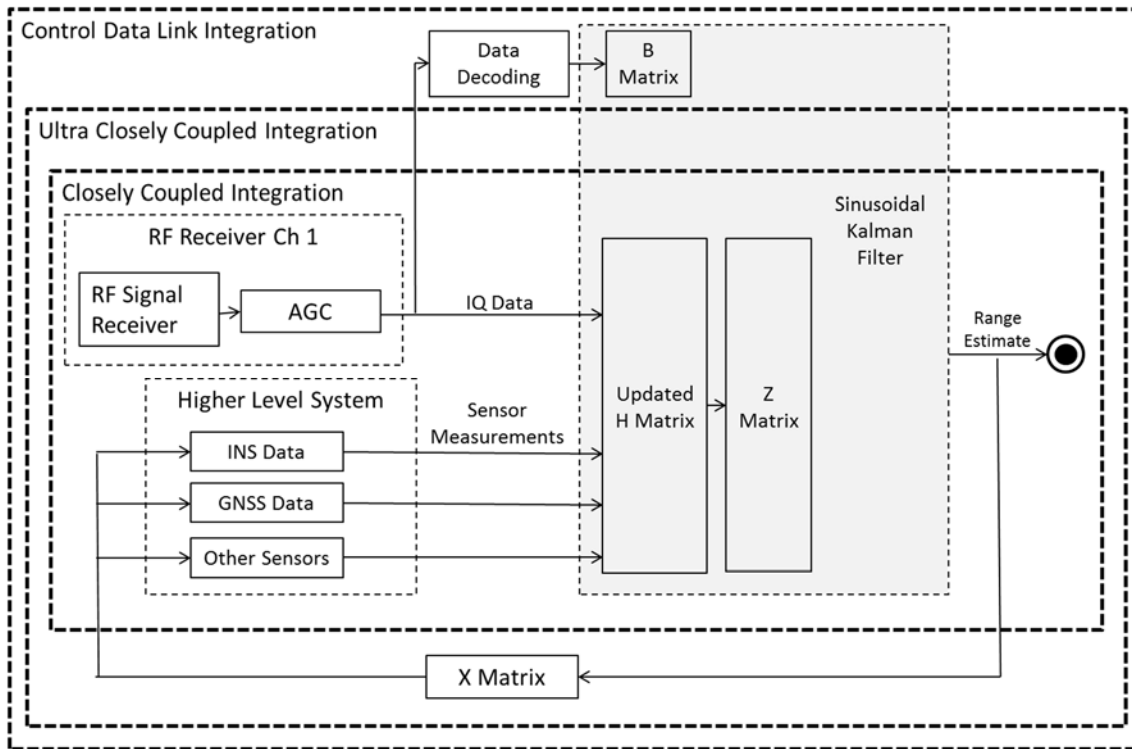

Figure 3 – Three stage system integration with additional higher level navigation sensors. The figure describes the architecture required for closely coupled integration, ultra-closely coupled integration and a method for utilising encoded data in a control data link.

The method for integrating the proposed sinusoidal Kalman filter based system consists of three stages. Stage 1 will be the initial close coupling of additional navigation sensors into the sinusoidal Kalman filter, improving the robustness of the RF phase estimation. Stage 2 is the addition of a feedback loop. This allows the ultra-close coupling of the system, improving the performance of surrounding navigation sensors. Stage 3 is the addition of control link data from systems where the motion of the system is controlled via a RF data link.

Stage 1 of the system is an open loop closely coupled system where the sinusoidal Kalman filter measurements come from all available navigation sensors. Although methods exist for closely coupling navigation sensors to provide an improved geolocation estimate, the novel application of a sinusoidal Kalman filter to maintain an estimation of phase allows the additional data to be used to further improve the robustness of the system to multipath and other urban and indoor RF effects. The system requires an update to the Kalman filter H matrix and the addition of an F and Z matrix. The updated H matrix relates to the measurements received from each sensor. The F matrix converts the measured sensor reading into a phase estimate based on the calculated range from the transmitter. An example updated H and F matrix for a typical data stream with RF and GNSS data can be seen below.

$$H = \begin{bmatrix} 1 & 0 \\ 1 & 0 \end{bmatrix} \quad (16)$$

$$F = [1 \quad \sqrt{x^2 + y^2} * \sin(\omega\tau)] \quad (17)$$

Upon each time separation iteration of the Kalman filter the H matrix is multiplied by the corresponding F and then Z matrix.

$$Z = [a \ b] \quad (18)$$

The Z matrix is updated at each iteration, depending upon what fresh measurement data is available from the system. In the below example, if a raw RF data measurement is available, $a = 1$ and $b = 0$. If a GNSS measurement is available, $a=0$ and $b=1$.

This implementation allows the Kalman filter to be updated with all available data. The covariance of the H matrix is maintained by Kalman filter, providing additional robustness to multipath effects. Erroneous RF signals are identified by a lowering in the covariance values in the Kalman filter's P matrix and will have limited effect on the maintained phase estimate.

Following the integration of the additional navigation sensors an additional stage of ultra-close coupling is possible using conventional methods of using an X matrix to convert the range update back into a known position estimate for each sensor. The advantage of this technique for the proposed system is that further robustness to indoor and urban RF effects is provided, allowing a highly robust phase estimate to be maintained by the Kalman filter due to accurately maintained measurement covariance's in the P matrix.

The system architecture described so far is applicable to any signals of opportunity source, where the location of the transmitter is either known in advance or can be calculated using simultaneous localisation and mapping techniques. The system uses only the RF carrier signal, so can be used without knowledge of any of the data on the link. Even encrypted data links can be used to provide a ranging estimate.

The movement of many robotic systems is controlled by an RF data-link. This data-link is likely to provide an ideal RF data source from a known transmitter location and could be utilised in many systems. In systems that use the control datalink as the RF input to the system, the data contained within the data-link can be decoded, providing the commanded system motion. This commanded motion can be, via a control matrix (B), used to update the prediction estimate made by the Kalman filter. The B matrix is multiplied with the Φ matrix, allowing the prediction part of the Kalman filter to account for the motion expected by the system. The B Matrix must have a prior knowledge of the system dynamics that will apply following any commanded motion input. Once again, the addition of an improved prediction estimate within the Kalman filter will provide additional robustness to measurement uncertainty. The ability for the system to command data in this way is a unique benefit that comes from using signal of opportunity inputs into a sinusoidal Kalman filter architecture.

5 Simulation and Experiment

5.1 Simulation

The performance of the proposed sinusoidal Kalman filter based system will be simulated in a typical urban environment. The aim of the simulation is to allow an analysis of the proposed approach alongside that of the most widely adopted prior art [13], enabling a comparison of performance to be made. The simulation has created a radio fingerprint of the dense urban environment shown in Figure 4 with signals generated from point A.

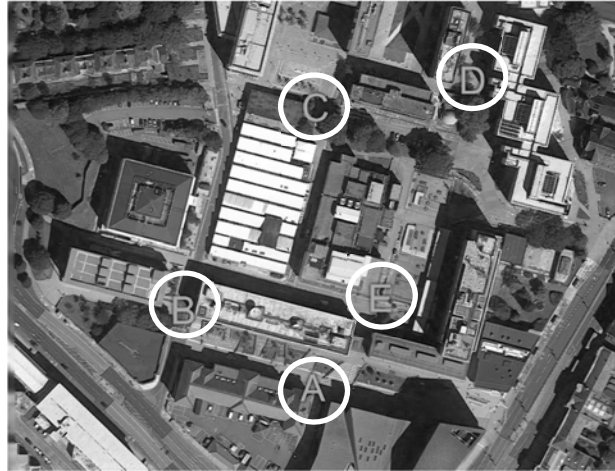

Figure 4 - Urban Environment with Simulated Reception Points

Reception points B to E have been selected to allow performance analysis at both near and long range and, to simulate performance in areas of high and low multipath, areas of high and low building density. The results are show in Figure 5 and Table 2.

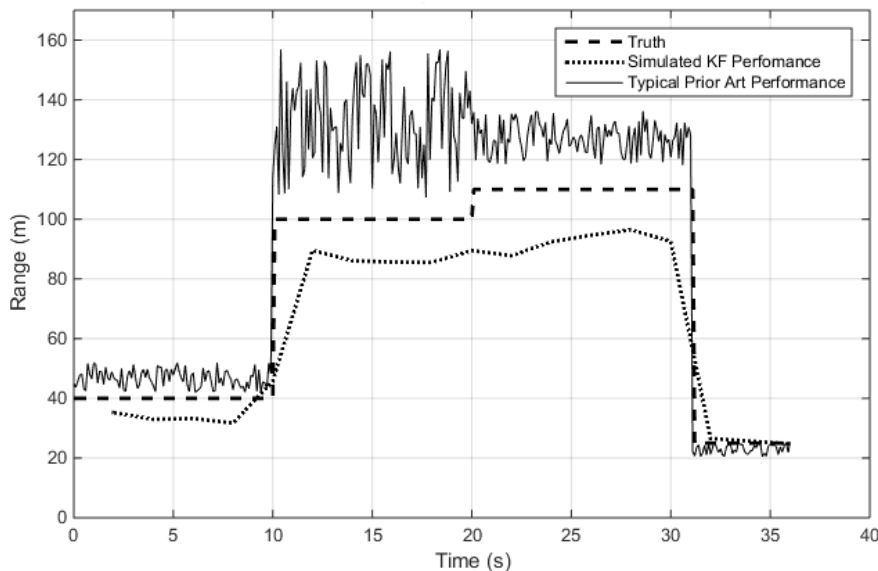

Figure 5 – Simulated range estimate provided at points B to E with respect to point A for 2 ranging methods.

Table 2 - Tabulated Range Estimate Averages

Reception Point	Reception Environment		True Range (m)	Average Error (m)		Improvement (%)
	Range	Building Density		Prior Art Method	Proposed Method	
B	Near	High	40	6.7	5.8	13
C	Long	Low	100	33.2	10.8	67
D	Long	High	110	17.3	15.3	12
E	Near	Low	25	2.0	0.7	65

While the greatest improvements have been made in areas of relatively low multipath, greater ranging accuracy has been achieved at all reception points with the average error reducing from 14.8 m with the prior art to 8.2 m with the proposed method.

5.2 Hardware Benchmarking

To validate and benchmark the system improvements obtained, the proposed method has been tested with hardware at the point shown in simulation to be the most challenging, reception point D. The system has been tested in the incremental stages outlined in section 4. Each stage has been tested to validate the proposed technique and to provide evidence that the anticipated performance has been achieved. All testing has been carried out with a drone, modified to be controlled with a 27 MHz amplitude modulated transmitter. The flying drone contains a micro electro-mechanical system (MEMS) IMU with 3 accelerometers and 3 gyros. The Single RF channel has been recoded using a low power software defined radio (SDR) receiver attached to the drone. The test apparatus can be seen in the photographs below. A smart phone GPS receiver has been added to the drone to provide comparative GNSS geolocation data.

**Figure 6 – Drone System****Figure 7 – SDR Receiver****Figure 8 – 27 MHz Transmitter**

The test area was in a densely populated urban city centre location with tall buildings surrounding the trial. A clear view of the sky above the trial was present, although sight was limited by tall buildings on all sides. The test consists of a 60 second drone flight at a constant altitude of 6 feet. The flight profile consisted of the 4 steps shown in Figure 9.

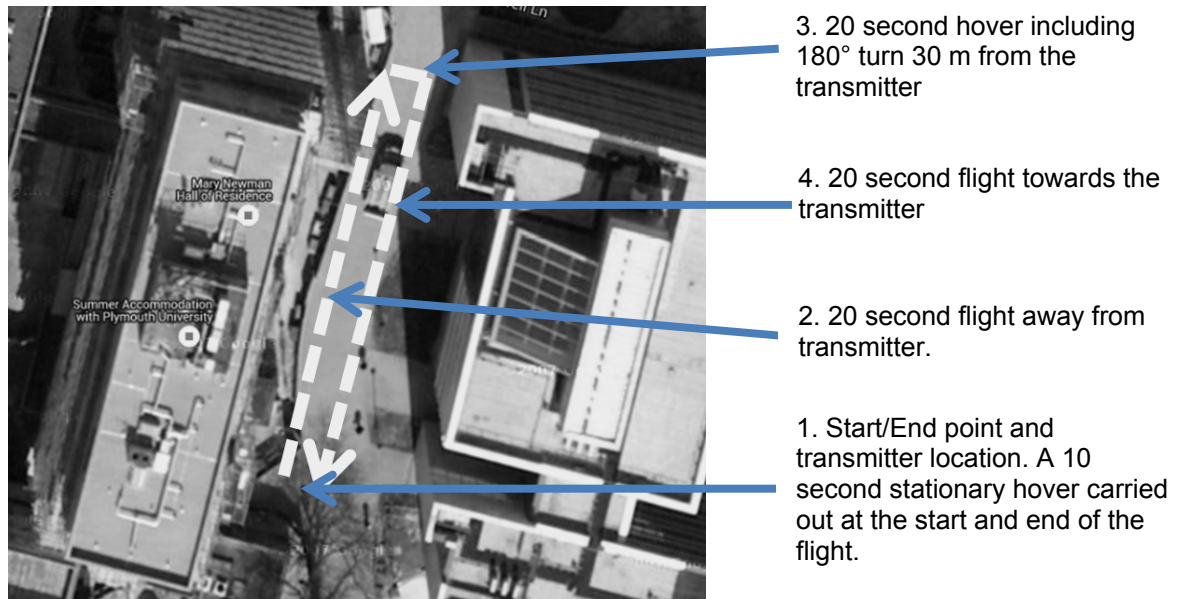

Figure 9 - Test Flight Map

All data has been collected in separate files for post processing. Post processing has been carried out on the data recorded by each of the trial sensors. Raw IMU and GPS data has been collected. These raw data sources, available to typical automated robotic systems, have been plotted throughout the test trial in Figure 10.

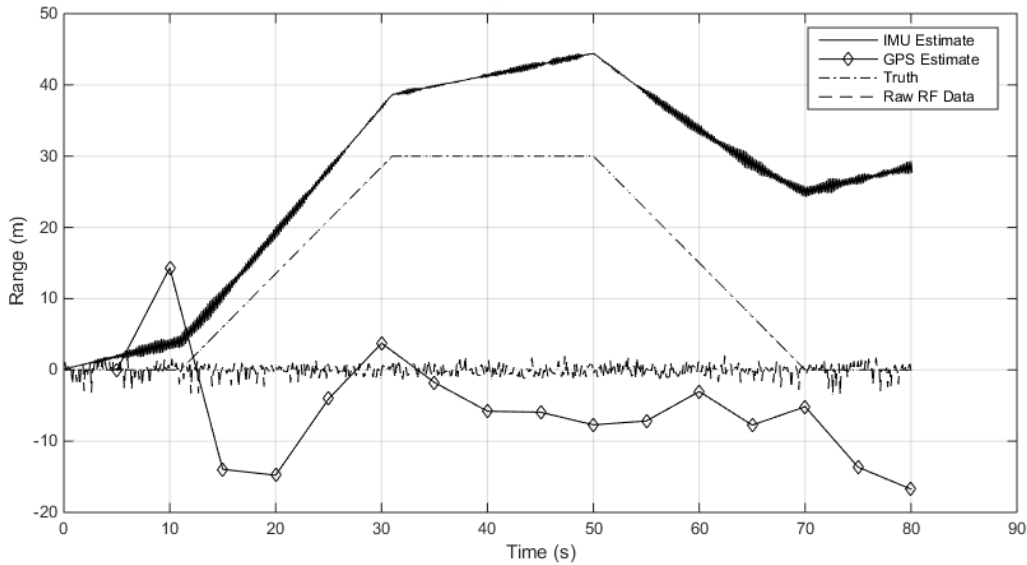

Figure 10 – Ranging estimate from the raw data sources.

The data presented in Figure 10 shows the challenges faced by many systems navigating in an urban environment. The first challenge is the poor fidelity of the GPS location provided in a dense urban environment; it is hard to determine any component of the flight during the trial. The poor performance of the GPS is typical when receiving signals in urban environments. The inertial data presented by the INS system shows that the stages of the flight can be determined; however the significant drift of approximately 30 meters at the end of an 80 second flight presents the second challenge of error integration. The inertial drift will continue to accumulate for the entirety for the mission without the aid of an external data source. Whilst this paper aims to use the RF signal present in the systems control datalink to provide an external source of navigation data, it is hard to see how this data source could provide information when the time domain RF amplitude data is plotted. Due to the limited flight range and the fact that the datalink contains an automated gain control loop, the amplitude of the raw RF data does not appear to provide any useful ranging information. The raw data obtained from the flight appears to show that accurate, low drift navigation for a drone system, using only the existing hardware will be a very challenging task. The techniques proposed by this paper shall now be applied in stages to show the contribution of each technique in building an accurate drift free navigation solution.

As described in section 4, the raw RF data will be fed through the Kalman filter to create a low noise sinusoid of the raw RF carrier signal. The phase of this low noise sinusoid is analysed and shifts in the maintained phase estimate have been used to estimate a change in range from the transmitter to the recording receiver mounted on the drone. Analysing the data's phase shift with a sinusoidal Kalman filter provides the ranging estimate shown in Figure 11.

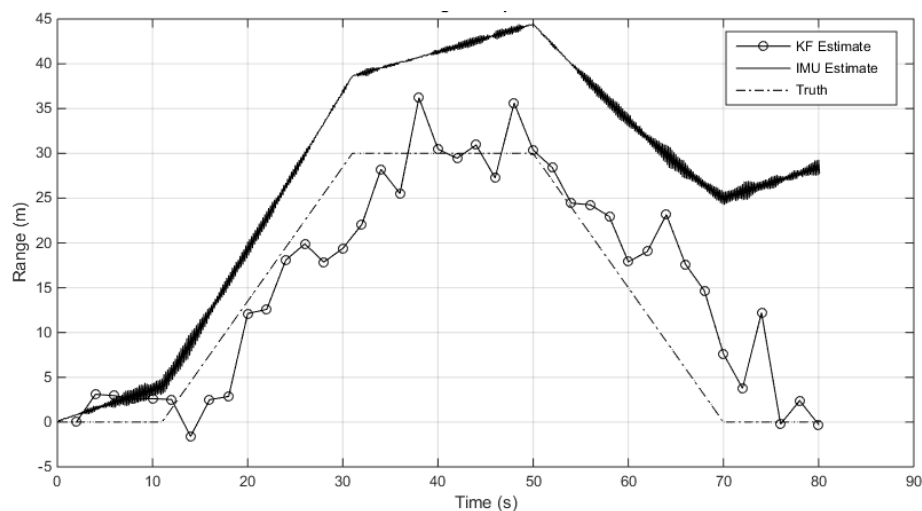

Figure 11 – Ranging estimate from the RF post sinusoidal Kalman filter processing.

It can be seen that by comparing the estimates from the low noise sinusoidal Kalman filter a low drift range estimate can be seen throughout the 80 second flight. This low drift ranging estimate was able to track the range changes with low latency throughout the flight, resulting in a good localisation estimate throughout the flight. As predicted, errors in the recordings throughout the flight don't integrate together and the estimate tends towards the true location at the stationary points in the data. The limitation of the processed RF data is that there that range estimation errors of up to 12 m are present for periods of several seconds. This may have been caused by multipath effects in the RF data due to the test being carried out at low altitude in a dense urban environment. The cause of this deviation will be determined in later testing but, even with this deviation, the observed performance is significantly better than existing navigation systems, providing evidence that the using the sinusoidal Kalman filter at the core of the system provides a significant benefit.

The next analysis proposed by this paper is designed to remove these short term errors by ultra-closely coupling the RF data with that of a low noise, but high drift INS system. This technique has been carried out and is presented in Figure 12.

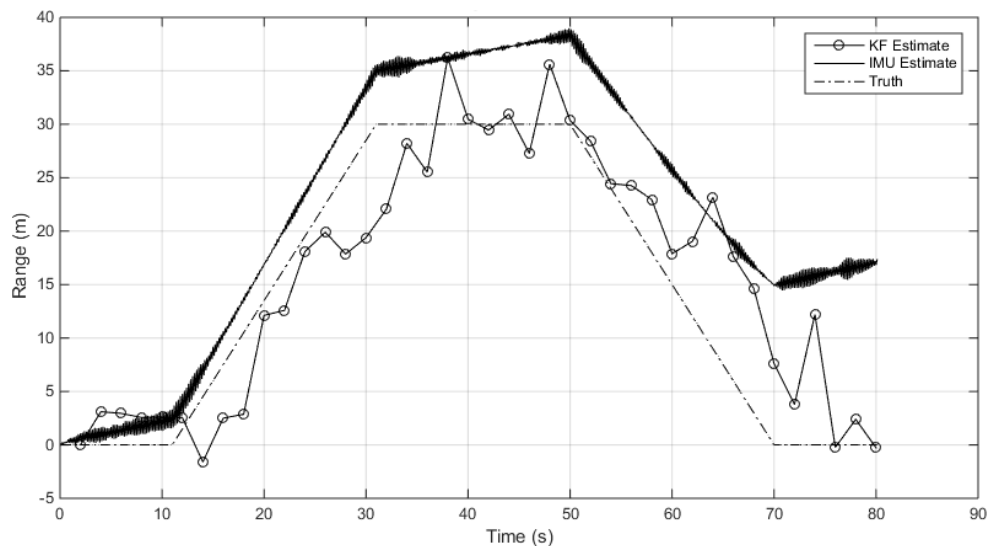

Figure 12 – Ranging estimate from the processed RF and ultra-closely coupled IMU data

It can be seen in the data provided that ultra-closely coupling the Kalman filter and IMU system has had an effect. The largest effect can be seen in the IMU drift. The integrated error at the end of the flight has reduced from 28 m in the uncoupled trial to 17 m in the coupled trial. The magnitude of the IMU following coupling is strongly linked to the Kalman filter estimate in the stationary period in the first 10 seconds of the trial where the Kalman filter P matrix experiences a period of convergence on the present system errors. Another key observation is that the output from the Kalman filter has changed very little and the deviations of up to 12 m remain. This suggests that the deviations are not in fact caused by multipath and another unknown error source is dominating the Kalman filter errors. Although the identification of this error source is proposed as further work, the systems resilience to multipath is likely to have been proven.

For many systems where the RF signal recorded by the drone mounted equipment is not controlled by the system operator, as found in many signal of opportunity systems where 3rd party RF networks are used as the data source, no further navigation data is available from the techniques proposed in this paper. The results presented in Figure 12 will be the final performance of the system. When this performance is compared with the GPS ranging estimate shown in Figure 10, a drastic performance improvement has been achieved. Even if the GPS data were to be combined with the INS data also shown in Figure 10, no accurate ranging estimate during the flight would have been provided; The GPS signal obtained in an urban environment was of such poor quality that the INS estimate could not have been improved by coupling it with the GPS signal with existing techniques. Coupling the INS data to the output of the proposed system has reduced the error at the end of the 80 second flight considerably.

Further to this already considerable improvement in performance over existing INS coupling systems, the drone system under test is controlled by a frequency modulated command signal which is operated by the system designer. This command signal is used to provide the stop, forward, backwards, turn left and turn right commands to the drone and is decoded by the on-board RF receiver. This data can be made available to the filter along with a basic kinematic model representation of the drone. The following information about the kinematic model is known and is captured in the trial B matrix:

Forward motion is typically 5 m/s

Turn rate is typically 90 °/s.

The resulting ranging estimate from using this data as described in section 4 is presented in Figure 13.

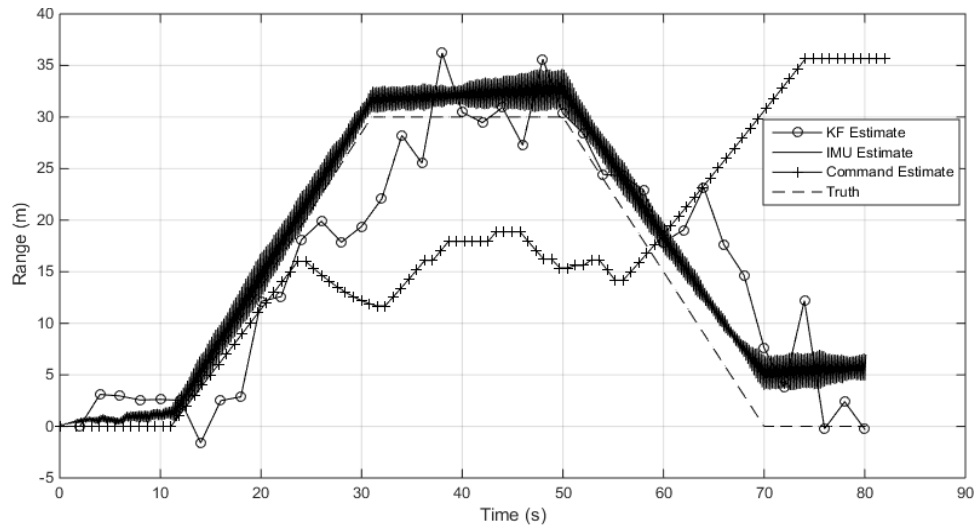

Figure 13 – Ranging including data obtained from the encoded data.

The addition of the encoded data reveals further detail about the system behaviour. The first thing to note is the fact that the assumed kinematic model appears to be incorrect. The system appears to have not correctly measured the 180° yaw command at the turning point half way through the trial. Despite this, the Kalman filters estimated range remains accurate. The benefit of adding the decoded command data is seen in the first 10 seconds of the trial where the P matrix is converging. The addition of the stop command information has allowed the Kalman filter to better remove the IMU biases. This has reduced the integrated IMU drift at the end of the trial from 17 m to 5 m. This will again further increase the systems resilience to multipath and other urban and indoor RF effects.

The Kalman filter errors throughout the hardware test has been analysed. The average error between truth and the Kalman filter estimate was recorded to be 3.3 m with a 3σ error prediction of 12 m. The performance of the proposed technique, compared against existing methods in a similar environments, as described in section 3, can be seen in Table 3.

Table 3 - Estimated geolocation accuracy comparison in a dense urban environment.

Technique	Typical Error (m)	Notes
<i>Proposed Technique</i>	12	<i>12 m (3σ) error achieved with hardware test. No prior knowledge of a 3rd party system required.</i>
WiFi SLAM ^[9]	10	Prior knowledge of 3 rd party infrastructure required.
Coupled signal of opportunity ^[13]	20	The most widely adopted technique in current research if no environmental prior knowledge is available.

Hardware test of the geolocation techniques researched in this paper have provided a reduction in geolocation error indoor and urban environments over existing techniques. While the system has proven resilient to the presence of an erroneous kinematic model in the test, further optimisation of this parameter is likely to allow the achieved performance to match that of systems that can utilise prior knowledge of the environment, overcoming a common system application constraint.

6 Conclusions

Mature systems exist that closely couple INS and GNSS data to enable an improved geolocation estimate. Initial testing in a typical urban environment has showed that, as predicted, GNSS performance is limited by a combination of poor line of sight view of the sky, multipath effects and poor performance of low size, power and weight GNSS receivers common to many small robotic and IoT systems produce considerable geolocation errors. GNSS does not provide a suitable external coupling partner for INS systems in these systems. Research has also been carried out into using signals of opportunity to provide a ranging estimate. These systems are adversely affected by multipath in urban environments or require prior knowledge of 3rd party data-links to provide a ranging estimate.

This paper has presented novel techniques for using a single RF data source to maintain a ranging estimate by comparing the predicted output of a sinusoidal Kalman filter with a noisy recorded RF signal. This comparison allows a low latency ranging estimate to be produced that provides resilience to the adverse effects of multipath. Testing has shown that in a typical urban environment this ranging estimate can be coupled to the output of an INS to produce a high fidelity and robust ranging estimate. Further, an addition to the basic technique allows for closer coupling of the signals of opportunity system and the existing INS system can be made if the contents of the data-link message can be decoded by the target system.

This paper has presented a significant improvement on the resilience and robustness of signals of opportunity systems and allows them to provide a reliable external source of information for ranging systems without the need for any additional system hardware. Further, this technique effectively removes a common design constraint that previously limited geolocation performance in many applications. This will enable system designers to gain more information from their mobile robotic and IoT data, enabling the next generation of advanced urban information networks.

The testing carried out in this paper is extremely encouraging but limited to a single 80 second flight in an urban environment. Further work is required to characterise the performance of the system in a range of environments and test scenarios.

7 References

- [1] N.E. Klepeis et al, "The National Human Activity Pattern Survey (NHAPS): a resource for assessing exposure to environmental pollutants.".2001. US National Library of Medicine, May-Jun 2001.
- [2] Air Commodore Norman Bonnor, "A Brief History of Global Navigation Satellite Systems," Royal Institute of Navigation Journal of Navigation vol. 65, Jan 2012.
- [3] Novatel, "IMU Errors and Their Effects" 2014. Novatel bulletin, 21st February 2015. <http://www.novatel.com/assets/Documents/Bulletins/APN064.pdf>. Accessed 17th December 2015.
- [4] R. Kalman, "A New Approach to Linear Filtering and Prediction Problems". Transactions of the ASME Journal of Basic Engineering, Vo, 82, Pages 35-45, 196
- [5] D.C. Salmon, D.M Bevly, "An exploration of low-cost sensor and vehicle model Solutions for ground vehicle navigation" 2014. Published in IEEE PLANS 2014, 5-8 May 2014.
- [6] Li T. et al. "Ultra-tight Coupled GPS/Vehicle Sensor Integration for Land Vehicle Navigation." 2010. University of Calgary. Navigation, Vol. 57, No. 4, pp. 248-259.
- [7] R. Negenborn, "Robot Localization and Kalman Filters – On finding your position in a noisy world", 2003. Thesis, Utrecht University, 1st September 2003.
- [8] F. Kong, Y. Chen, J Xie and G. Zhang, "Mobile Robot Localization Based on Extended Kalman Filter" 2006. 2006 6th World Congress in Intelligent Control and Automation (Volume 2). 2006.
- [9] A. Papapostolou and H. Chaouchi, "Scene Analysis Indoor Positioning Enhancements", 2011. Ann. Telecommun. 2011.
- [10] A. Roxin, J. Gaber, M. Wack, A. Nait-Sidi-Moh, "Survey of Wireless Geolocation Techniques" 2007. UTBM, France. IEEE Globecom Workshop 2007.
- [11] N.A Alsindi, "Performance of TOA Estimation Algorithms in Different Indoor Multipath Conditions.". PhD Thesis, Worcester Polytechnic Institute, April 2004.
- [12] I Selmi and N Samama, "Indoor positioning with GPS and GLONASS-like signals use of new codes and a repealite-based infrastructure in a typical museum building" , 2014. Ann. Telecommun. 2014.
- [13] R. M Faragher, P.J Duffett-Smith, "Measurements of the effects of multipath interference on timing accuracy in a radio positioning system," *IET Radar, Sonar and Navigation*, vol. 4, iss. 6, pp. 818-824. 2010.
- [14] R. M. Faragher, "Effects of Multipath Interference on Radio Positioning Systems," Ph.D. dissertation, Dept. Physics., University of Cambridge, Cambridge, UK. 2007
- [15] Jeffrey H. Reed, Kevin J. Krizman, Brian D. Woerner, and Theodore S. Rappaport, "An Overview of the Challenges and Progress in Meeting the E-911 Requirement for Location Service". Virginia Tech, 1998. Published in the IEEE Communications Magazine, April 1998
- [16] D. Arnitz, K. Witrisal and U. Muehlmann, "Multifrequency Continuous-Wave Radar Approach to Ranging in Passive UHF RFID". 2009. IEEE Transactions on Microwave Theory and Techniques, Vol. 57. No 5, May 2009.
- [17] M. Pelka, C. Bollmeyer and H. Hellbruck, "Accurate Radio Distance Estimation by Phase Measurements with Multipole Frequencies". 2014. International Conference on Indoor Positioning and Indoor Navigations, 27th October 2014.
- [18] Arnold, W.F, A.J. Laub, "Generalized Eigenproblem Algorithms and Software for Algebraic Riccati Equations," Proc. IEEE, 72 (1984), pp. 1746-1754