

2016

# Mental Imagery in Humanoid Robots

Seepanomwan, Kristiana

<http://hdl.handle.net/10026.1/4581>

---

<http://dx.doi.org/10.24382/4109>

Plymouth University

---

*All content in PEARL is protected by copyright law. Author manuscripts are made available in accordance with publisher policies. Please cite only the published version using the details provided on the item record or document. In the absence of an open licence (e.g. Creative Commons), permissions for further reuse of content should be sought from the publisher or author.*

# **MENTAL IMAGERY IN HUMANOID ROBOTS**

by

**Kristsana Seepanomwan**

A thesis submitted to the Plymouth University in partial fulfilment for the degree of

**Doctor of Philosophy**

School of Computing, Electronics and Mathematics  
Faculty of Science and Engineering

April 2016



## **Copyright Statement**

This copy of the thesis has been supplied on condition that anyone who consults it is understood to recognise that its copyright rests with its author and that no quotation from the thesis and no information derived from it may be published without the author's prior consent.



Kristsana Seepanomwan

## Mental Imagery in Humanoid Robots

### **Abstract**

Mental imagery presents humans with the opportunity to predict prospective happenings based on own intended actions, to reminisce occurrences from the past and reproduce the perceptual experience. This cognitive capability is mandatory for human survival in this folding and changing world. By means of internal representation, mental imagery offers other cognitive functions (e.g., decision making, planning) the possibility to assess information on objects or events that are not being perceived. Furthermore, there is evidence to suggest that humans are able to employ this ability in the early stages of infancy.

Although materialisation of humanoid robot employment in the future appears to be promising, comprehensive research on mental imagery in these robots is lacking. Working within a human environment required more than a set of pre-programmed actions. This thesis aims to investigate the use of mental imagery in humanoid robots, which could be used to serve the demands of their cognitive skills as in humans. Based on empirical data and neuro-imaging studies on mental imagery, the thesis proposes a novel neurorobotic framework which proposes to facilitate humanoid robots to exploit mental imagery. Through conduction of a series of experiments on mental rotation and tool use, the results from this study confirm this potential.

Chapters 5 and 6 detail experiments on mental rotation that investigate a bio-constrained neural network framework accounting for mental rotation processes. They are based on neural mechanisms involving not only visual imagery, but also affordance encoding, motor simulation, and the anticipation of the visual consequences of actions. The proposed model is in agreement with the theoretical and empirical research on mental rotation. The models were validated with both a simulated and physical humanoid robot (iCub), engaged in solving a typical mental rotation task. The results show that the model is able to solve a typical mental rotation task and in agreement with data from psychology experiments, they also show response times linearly dependent on the angular disparity between the objects. Furthermore, the experiments in chapter 6 propose a novel neurorobotic model that has a macro-architecture constrained by knowledge on brain, which encompasses a rather general mental rotation mechanism and incorporates a biologically plausible decision making mechanism. The new model is tested within the humanoid robot iCub in tasks requiring to mentally rotate 2D geometrical images appearing on a computer screen. The results show that the robot has an enhanced capacity to generalize mental rotation of new objects and shows the possible effects of overt movements of the wrist on mental rotation. These results indicate that the model represents a further step in the identification of the embodied neural mechanisms that might underlie mental rotation in humans and might also give hints to enhance robots' planning capabilities.

In Chapter 7, the primary purpose for conducting the experiment on tool use development through computational modelling refers to the demonstration that developmental characteristics of tool use identified in human infants can be attributed to intrinsic motivations. Through the processes of sensorimotor learning and rewarding mechanisms, intrinsic motivations play a key role as a driving force that drives infants

to exhibit exploratory behaviours, i.e., play. Sensorimotor learning permits an emergence of other cognitive functions, i.e., affordances, mental imagery and problem-solving. Two hypotheses on tool use development are also conducted thoroughly. Secondly, the experiment tests two candidate mechanisms that might underlie an ability to use a tool in infants: overt movements and mental imagery. By means of reinforcement learning and sensorimotor learning, knowledge of how to use a tool might emerge through random movements or trial-and-error which might reveal a solution (sequence of actions) of solving a given tool use task accidentally. On the other hand, mental imagery was used to replace the outcome of overt movements in the processes of self-determined rewards. Instead of determining a reward from physical interactions, mental imagery allows the robots to evaluate a consequence of actions, in mind, before performing movements to solve a given tool use task.

Therefore, collectively, the case of **mental imagery in humanoid robots** was systematically addressed by means of a number of neurorobotic models and, furthermore, two categories of spatial problem solving tasks: mental rotation and tool use. Mental rotation evidently involves the employment of mental imagery and this thesis confirms the potential for its exploitation by humanoid robots. Additionally, the studies on tool use demonstrate that the key components assumed and included in the experiments on mental rotation, namely affordances and mental imagery, can be acquired by robots through the processes of sensorimotor learning.

# Contents

Acknowledgement	1
Author's Declaration	2
<b>1. Introduction</b>	<b>4</b>
1.1 Sensorimotor Experience and Mental Imagery	4
1.2 Motivation of the Thesis	6
1.3 Objectives	10
1.4 Contribution to Knowledge	10
1.5 Structure of the Thesis	11
<b>2. Background on Mental Imagery</b>	<b>14</b>
2.1 Sensorimotor Learning	14
2.2 Internal Models	16
2.3 Mental Imagery in Psychology and Neuroscience	18
2.4 Mental Imagery in Robots	22
2.5 Mental Rotation	25
2.5.1 Brain areas and neural mechanisms involved in mental rotation	30
2.6 Mental Rotation Models	33
2.7 A Comprehension of Infants' Tool Use	35
2.8 Tool Use in Robots	38
<b>3. Background on Cognitive Robotics and Neurorobotics</b>	<b>40</b>
3.1 Introduction	40
3.2 Cognitive Robotics and Neurorobotics	41
3.2.1 Cognitive Robotics	42
3.2.2 Neurorobotics	44
3.3 Cognitive Robotics and Neurorobots: A Synthetic Approach to Understand Cognition	48
3.3.1 Cognitive Development	48
3.3.2 Learning	51
3.3.3 Imitation	55
3.3.4 Language Grounding	59
<b>4. Tools for Modelling Mental Imagery</b>	<b>62</b>
4.1 TRoPICALS	62
4.2 Population Coding	65
4.3 Learning Algorithms	66
4.3.1 Hebbian: Supervised Learning	66
4.3.2 Kohonen: Competitive Learning	68
4.4 The Humanoid Robot iCub	70
<b>EXPERIMENTAL STUDIES</b>	<b>74</b>
<b>5. Modelling Mental Rotation</b>	<b>76</b>
5.1 Experiment 1: A cognitive Robotic Model of Mental Rotation	77
5.1.1 Methods	78

5.1.2 Results	86
5.1.3 Discussion	91
5.2 Experiment 2: Motor Processes and Mental Rotation	94
5.2.1 Methods	94
5.2.2 Results	106
5.2.3 Discussion	111
<b>6. Generalisation Skills in Mental Rotation</b>	<b>113</b>
6.1 Experiment 3: Mental Rotation and Generalisation Skills	114
6.1.1 Methods	115
6.1.2 Results	125
6.1.3 Discussion	127
6.2 Experiment 4: Generalisation, Decision Making and Embodiment Effects in Mental Rotation	128
6.2.1 Methods	130
6.2.2 Results and discussion	143
<b>7. The Role of Sensorimotor Learning and Mental Imagery in the Development of Tool Use</b>	<b>156</b>
7.1 Experiment 5: Tool Use Development in Infant Robots	157
7.1.1 Introduction	157
7.1.2 Methods	160
7.1.3 Results	182
7.1.4 Discussion	185
<b>8. Conclusion</b>	<b>188</b>
8.1 Summary on the Initial Models of Mental Rotation	188
8.2 Summary on the Generalise models of Mental Rotation	189
8.3 Summary on Tool Use Development in Infant Robots	193
8.4 Contribution to Knowledge	195
8.5 Future work	198
<b>References</b>	<b>201</b>

# List of Figures

2.1 A schematic diagram of pathways activated during three observations: (a) visually guide reach. (b) observation of action. (c) execution of imitated action (from Miall, 2003).....	17
2.2 The key brain areas involved in mental rotation and considered in the model.....	30
4.1 The TRoPICALS's model architecture.....	64
4.2 An example of a 2D Hebbian network with all neurons from the input layer connect to allneurons of the output (all-to-all connection).....	67
4.3 An example topology of the Kohonen network.....	69
4.4 The iCub humanoid robot. (a) Real robot. (b) Simulated robot.....	71
5.1 The model of mental image rotation ©2013 IEEE (1 <sup>st</sup> model, Experiment 1).....	79
5.2 The iCub simulator and its environment ©2013 IEEE.....	84
5.3 The two stimuli used for the simulated mental rotation task ©2013 IEEE.....	85
5.4 Mental image rotation steps, 1 <sup>st</sup> model: (a) Rotational steps in the case that the model is able to create a series of image changes to reach the 0 degrees default orientation (b) the model is unable to rotate the seen object ©2013 IEEE...	87
5.5 RTs profiles of the simulated mental rotation task: (a) The rotation of different stimuli affects the RTs profile (b) Series of some unseen and seen stimulus orientations of object-A ©2013 IEEE.....	91
5.6 The model of mental image rotation (2 <sup>nd</sup> model, Experiment 2).....	98
5.7 Mental image rotation steps, 2 <sup>nd</sup> model: (a) rotational steps in the case that the model is able to create a sequence of rotated images to reach the target orientation (b) case in which the model is unable to rotate the seen object.....	110
5.8 The comparison of response time profiles with different proprioceptive signals: (a) Difference of response time profiles between different pairs of stimuli (b) Difference of response times when supplying a matching, mismatching, or no proprioceptive signal to SS.....	110
6.1 Stimuli used for training and recognition test (a) and for generalization tests (b, c). Each image is formed by one object shown two times, here with a 0° orientation and with main appearance.....	116
6.2 The neural network model for mental rotation (3 <sup>rd</sup> model).....	122
6.3 Patterns generation for the forward model learning.....	123
6.4 Forward model learning.....	124
6.5 Experimental results.....	126
6.6 (a) Stimulus set A used for training and for the recognition test (Recog). (b, c) Stimulus sets used for the generalization tests (respectively Ge1 and Gen3). (d) Three object-pair images used during the tests.....	132
6.7 The neural network model controlling the robot in the mental rotation task (4 <sup>th</sup> model).....	133

6.8	Illustration of the procedure used to train the forward models of the system.....	141
6.9	Performance of the model during the three mental rotation tests: (a) Response times (RT) (b) Error rates (ER) (c) Correct response (CR).....	146
6.10	Comparison of the results when supplying the model with match and mismatch of proprioceptive input from the robot wrist: (a) Response times (b) Error rates (c) Correct responses.....	149
6.11	Comparison of the results when the model receives congruent or incongruent proprioception in the case of the Gen1 image dataset.....	150
6.12	Activation of different areas of the model, indicated in the top row of each graph panel, while the system mentally rotates objects from the three datasets: (a) Recog (b) Gen1 (c) Gen2.....	152-153
6.13	Activation of key areas of the model when it is supplied proprioceptive information in the case of mental rotation of the same object used in Figure 6.12a: (a) Case where proprioception is congruent with mental rotation. (b) Case where proprioception is incongruent with mental rotation.....	154
7.1	The iCub simulator and a sample tool use scenario.....	162
7.2	Four initial postures and four initial tool use situations.....	163-164
7.3	Interesting events caused by the interaction between the tool and the toy.....	165
7.4	The model of tool use development.....	167
7.5	Learning algorithm on skill acquisition.....	174
7.6	Learning algorithm on problem solving (Action sequencing).....	175
7.7	The difference between basic and a reinforcement learning DMPs.....	179
7.8	Examples of the network connection of the model after passing through the learning processes.....	181
7.9	Tool use performance when varying the number of skills. (a) Reactive system. (b) Planning system.....	184
7.10	Tool use performance when varying the number of training trials. (a) Reactive system. (b) Planning system.....	185

# List of Tables

5.1 The parameters used in the network.....	103
6.1 Key features of the neural maps of the model.....	135
6.2 Key features of the connections of the model.....	136
7.1 Constraint for skill acquisition.....	166

## **Acknowledgements**

I would like to express my grateful to my supervisor, Prof. Angelo Cangelosi for his help, support, friendliness, expertise and for accepting me as one of his students. Without him this thesis would not be possible.

I would like to thank my supervisory team, Dr. Gianluca Baldassarre and Dr. Daniele Caligiore. During the period of my thesis they suggested, discussed and taught me a lot of insightful ideas, and backgrounds regarding computational and cognitive models which are applied throughout this thesis.

I would also like to thank Dr. Alessandro Di Nuovo who helped refine my ideas on the model of mental imagery.

Many thanks should go to Dr. Davide Marocco and Prof. Santo Di Nuovo, the examiners. Who provided invaluable suggestions and comments that help improve my thesis.

Last but not least, I would like to thank Lalita Seepanomwan for all her love, patience and encouragement.

To my family, to Lalita

## Author's Declaration

At no time during the registration for the degree of Doctor of Philosophy has the author been registered for any other University award without prior agreement of the Graduate Committee.

Work submitted for this research degree at the Plymouth University has not formed part of any other degree either at Plymouth University or at another establishment.

This study was financed by a grant from Ministry of Science and Technology, the Thai Government.

## Publications:

- Seepanomwan, K., Caligiore, D., Baldassarre, G., Cangelosi, A. (2013). *A cognitive robotic model of mental rotation*. IEEE Symposium on Computational Intelligence, Cognitive Algorithms, Mind, and Brain (CCMB2013).
- Seepanomwan, K., Caligiore, D., Baldassarre, G., Cangelosi, A. (2013). Modelling mental rotation in cognitive robots. *Adaptive Behavior*, 21(4), 299-312.
- Seepanomwan, K., Caligiore, D., Cangelosi, A., Baldassarre, G. (2015). Generalization, Decision Making and Embodiment Effects in Mental Rotation: A Neurobotic Architecture Tested with a Humanoid Robot. *Neural Networks*, 72, 31-47.

## Attended conference and summer schools:

- The iCub Summer School (Veni Vidi Vici 2012), 18–27 July 2012, Sestri Levante, Genoa, Italy.
- IEEE Symposium Series on Computational Intelligence (IEEE SSCI 2013), 16-19 April 2013, Singapore.
- Neuronal Dynamic Approaches to Cognitive Robotics Summer School (DFT 2013), 9-14 September 2013, Bochum, Germany.

**Word count of main body of thesis:** 54,358

Signed .....

Date .....

## Quote

*Intelligence does not by any means appear at once derived from mental development, like a higher mechanism, and radically distinct from those which have preceded it.*

*Intelligence presents, on the contrary, a remarkable continuity with the acquired or even inborn processes on which it depends and at the same times makes use of.*

*Thus, it is appropriate, before analysing intelligence as such, to find out how the formation of habits and even the exercise of the reflex prepare its appearance.*

*J. Piaget*

# Chapter 1

## Introduction

### 1.1 Sensorimotor Experience and Mental Imagery

During life, humans and other animals acquire knowledge by repeating the process of action-perception countless times. This process is called sensorimotor learning and it plays an important role in the acquisition of other cognitive capabilities (Piaget, 1952). Human infants learn many skills starting from little knowledge and by the age of two are able to use tools. Their motor and cognitive skills develop simultaneously with and rely strongly on, the maturation of their body as well as the brain. Complex skills can be acquired only if their underlying capability (cognitively and physically) have been mastered.

Tool use forms a good example of a cognitive skill that demonstrates cognitive development through sensorimotor learning. Because of the constraints of their immature bodies, human infants stay helpless for many months after birth. They play with objects from the early period of infancy. However, they start to use tools at about the age of 8 months (McCarty, Clifton, & Collard, 2001). This might be because, at about this age, their musculo-skeletal system, in particular the hands and arms, are strong enough to hold an object (i.e., a tool) for a period of time. In addition to the physical constraints, the infants must develop knowledge of how to manipulate objects with their hands. However, an insight of how to use a tool is not applicable in infants aged less than 18 months (Rat-Fischer et al., 2012).

In addition, the insight of how to use a tool can be viewed as possible through the use of mental imagery (e.g., the expectation of an action's outcome) to guide the action selection process. There is evidence that shows that human infants are able of exploiting this capability in tool use scenarios, after they have mastered the corresponding actions (e.g., Schlesinger & Langer, 1999). During this sensorimotor stage, they not only practice their actions but also observe the change in the environment which is caused by particular actions they make and form an association among them. As a consequence, infants are able to distinguish between possible and impossible outcomes of actions at a young age (Schlesinger & Langer, 1999, Möhring & Frick, 2013). Mental imagery can be viewed as a by-product of sensorimotor learning.

Another renown example on cognitive skills that clearly involves mental imagery is the case of mental rotation. Since it was first described by Shepard and Metzler in 1971, mental rotation has attracted enormous research interest in the field of cognitive psychology. This is in part due to the attempts to understand why comparing objects using imagery seems to reflect the same physical rules as overt rotation, considering that humans are capable of using imagery that is not limited by the laws of physics (Kosslyn, 1996). When participants were asked to perform a classical mental rotation task while performing a manual rotation (e.g., on a custom joystick) in both congruent and incongruent conditions with respect to the direction of rotation of the mental image. The results show that response times and error rates were lower when the direction of the two rotations (manual and mental) was congruent, whereas they were higher when the direction of the two rotations were inconsistent (Wexler, Kosslyn, & Berthoz, 1998; Wohlschläger, 2001). This evidence indicated a connection between sensorimotor processes and mental imagery.

Mental imagery refers to internal representations of objects and situations (Kosslyn,

1980; Shepard & Cooper, 1982). This internal representation or mental image contains spatial information corresponding to a depicted stimulus. According to these mental images, humans can assess spatial properties of perceived objects (e.g., shapes and sizes) that are demanded by other cognitive functions (e.g., decision making, planning).

Mental imagery also plays a key role in associative learning and memory (Paivio, 1969) as mediators or as an image-evoking value. Increasing of objects' concreteness makes memory and learning more efficient. Paivio (1969: page 243) stated that “Images are regarded as symbolic processes which are linked developmentally to associative experiences involving concrete objects and events”. According to this view, an ability to create and manipulate mental images could be assumed as the result of experience with objects and events during life or sensorimotor learning.

## **1.2 Motivation of The Thesis**

Since this thesis concerns research on endowing mental imagery capability in humanoid robots, this section will point out a promising stepping stone between these two. It is a concept of embodied cognition (Pecher & Zwaan, 2005; Pezzulo et al., 2011; Wilson, 2002) which primarily focuses on a central role that the body plays in the processes of cognitive acquisition. In humanoid robots, having a form of human body could offer them a possibility to acquire knowledge about their world through the processes of sensorimotor learning like in humans. Furthermore, to be more than a human-like robot, mental imagery could emerge in the robot's brain as by-product of the the sensorimotor experience.

An embodied view on human cognition concerns three aspects involving body, brain and environment (Pfeifer & Bongard, 2006). The key idea is that the body and the

brain permitted humans (and other animals) to make movements which, as a consequence, could modify their environment. This scheme considers how humans explore and obtain knowledge about their world through their body. Cognition in this vein is an association between actions and perceptions that an individual experiences during its life.

Embodied cognition highly concerns two types of cognitive processing, including top-down and bottom-up mechanisms. It is true that the brain controls the body, but the body is not just a collection of output devices. Every movement and perception acknowledge by the brain effects thought in terms of interconnected neuronal circuits. The top-down cognition such as categorisation, decision making and language can be acquired properly only if they integrate with bottom-up information from the body. For example, the deaf are unable to speak properly because they have a deficit in some parts of the hearing system (Rodda & Grove, 2013). The loss of auditory information causes deaf people of not to be able to imitate proper sounds in their pronunciation, which results in impaired or loss of speech. However, deaf are able to learn sign language using information from visual system instead. The knowledge about sign language is an association between particular forms of body postures taken from visual perception and their meaning was given by the sign language instructors. By this way, deaf are able to express their thought through their body postures and facial expressions instead of using verbal language.

In robots, the concept of embodied cognition offers a promising way to construct true intelligence by replicating the way humans acquire their knowledge into robotic platforms. According to this approach, building intelligent robots which acquire knowledge through their body, brain and interaction with their environment seems to be possible.

There is a big obstacle in the design of cognition in robots. Unlike humans, the hardware and software parts of robots are completely separated. For instance, a robotic platform might be constructed by a robotic company while a control program might be implemented by a neuroscientist. Even though there is a standard interface between software and hardware, these two entities are not mutually connected like the brain and the body of living organisms. Humans can sense every single touch applied on their body which is not found in robots at the moment. A humans' body grows up from baby size to adult size, which is not possible to model in machine. Actuators in a robotic system cannot be developmentally improved in performance or grow like the musculo-skeletal system of animals and humans. In particular the spinal cord which links sensations and motor commands from/to body parts to/from the brain has developed before birth. Most intelligence systems concentrate only on the parts of computations and algorithms in computers, and pay a little attention to the part of body. Robots' controllers have determined only on actuators' and sensors' values, which serve as outputs and inputs to a control system. Intelligence in this way is top-down processing, from computation to actions, which is not enough to model human cognitions.

The problem of biological body and maturation seems too difficult to tackle. Cangelosi and Schlesinger (2015) suggested that cognitive development in robots is more likely to be possible if starting with baby robots. Human infants, at birth, have a small number of acquired cognitive functions and through development of their sensorimotor, their cognitive skills become more and more developed. In robots, starting from having little knowledge and gradually acquiring in the same way as the human infants do, could be a promising way to tackle true intelligence in a developmental fashion (Asada et al., 2001).

Following the scheme of embodiment seems convincing to make robots acquire

knowledge through their body, brain, and interaction with their environment, like humans. To make the motivation more clear, the following provides answers to two obvious questions:

### *Why humanoid robots?*

Humanoid robots have become of increasing interest in many fields. Humanoid robots provide a unique feature which offers a human-like body structure (e.g., Metta et al., 2008). It is important that this unique feature permits a demonstration of cognitive acquisition in a similar way that humans perform. This is an important aspect underlying successfully acquired high level cognitive functions in humans. In particular, most of human activities in daily life are usually carried out by hands. There is evidence that the largest part of the motor area is dedicated to control movements of the hands (Purves et al., 2013). Hands are very important for humans' intelligence and evolution (Wilson, 1998). It is relatively difficult to make a point that other kind of robots (e.g., dogs, wheels, that do not have hands) acquires higher-level cognitive functions in a developmental and embodied way, as in humans. At least those robots usually have no manipulating arms, hands or fingers, thus they can not manipulate objects efficiently. In terms of applications, humanoid robots are well suited to the tasks that normally humans perform (e.g., housekeeping tasks). Many humanoid robotic platforms have been designed and dedicated to perform these tasks as human communities appear to have a greater number of elderly people (Broekens et al., 2009, Bemelmans et al., 2012). Using humanoid robots as caregivers or servants seems promising to provide the needs of this service.

### *Why do humanoid robots need mental imagery?*

In terms of situated cognition and action sequencing, the use of mental imagery could allow humanoid robots to work together with humans in the humans' environment.

Since daily activities require a proper sequence of actions rather than a one stop action, robots without the capability to exploit mental imagery will not be particularly useful in real world situations.

Humanoid robots with mental imagery skills could crucially increase their planning abilities. Such robots, indeed, could “think” in advance the consequence of potential actions by mentally simulating the effect of them and, accordingly, could choose to explicitly perform the more suitable one to reach a given goal.

### **1.3 Objectives**

The aims of this thesis are, firstly, to reveal the possible bio-constraint neural mechanisms which underlie humans' cognitive processing through the particular case of mental imagery. Secondly, the research tends to allow a humanoid robot to perform tasks in a more human-like way. In which, the ability to use mental imagery will be integrated into their problem solving processes. Finally, a developmental robotics approach to model human cognitive acquisition will be simulated and assessed through the use of humanoid robots as a synthetic tool.

### **1.4 Contribution to Knowledge**

According to the design and implementation of several cognitive robotic/neurorobotics models capable of handling spatial problem solving tasks (i.e., mental rotation and tool use), this thesis provides four main contributions to the field of cognitive robotics.

- Scientific understanding of neuro-cortical mechanisms underlying mental rotation.

- Novel bio-constraint neurorobotics frameworks linking motor processes, mental imagery and spatial problem solving.
- Novel demonstration of integrating mental imagery capability into a humanoid robotic platform.
- Novel mechanism permitting an autonomous cognitive acquisition in humanoid robots.

The detail of each contribution listed above will be found in the final chapter.

## **1.5 Structure of the Thesis**

The thesis contains eight chapters. Chapter 1-4 provide an overview of the experimental and robotics literature used in the thesis. Chapter 5-7 describe experimental studies, results and discussion of the findings, followed by conclusions and suggested future work in the final chapter.

**Chapter 2** presents background knowledge on the possible link between sensorimotor learning and other cognitive functions such as mental imagery, mental rotation and tool use. The chapter points to the fact that by having experience with objects in the environment during life, agents acquire knowledge not only on what they can do but also the expectation of what will happen if they perform that action. The chapter also explains how the creation of mental imagery was linked to the processes involved in sensorimotor learning.

**Chapter 3** provides an introduction to robots and AI. A literature review on cognitive and neurorobotics and on a variety of studies using robots as a platform to acquire and express high level cognition are presented. The details on a variety of applications using

this new kind of robotic platforms as a synthetic approach to understand cognition, are also revealed.

**Chapter 4** details the techniques which were applied to create mental imagery in humanoid robots. The description of TRoPICALS, a computational model account for sensorimotor compatibility effect, population coding neural networks, learning algorithms and the humanoid robot iCub are included.

**Chapter 5** details two mental rotation models. The first model accounts for the mental rotation processes which are based on neural mechanisms involving visual imagery, affordance encoding and forward models processing. The second model highlights the importance of motor processes and proprioceptive inputs in the performance of mental rotation tasks.

**Chapter 6** reports another two models of mental rotation which generalise the mental rotation ability to unseen objects. It is demonstrated that the third and fourth model are able to generalize mental rotation skills to novel objects. This is an important result with respect to the previous version of the model (chapter 5). An innovation of these models is represented by the mechanism used to monitor the overall mental rotation process and to make the decision about the response to produce. To this end, the model incorporates the mutual inhibition model (Usher & McClelland, 2001; Bogacz et al., 2006) that allows a more accurate and biologically-plausible reproduction of the decision making processes of the participants in target psychological experiments. This chapter demonstrates how endowing the controller of a humanoid robot with some functional features of the human brain mental rotation areas makes it able to show some level of generalisation of mental image rotation.

**Chapter 7** demonstrates the role of sensorimotor learning and mental imagery in an acquisition of tool use competence. In this chapter, tool use development in human

infants was studied and replicated in a simulated infant robot (the iCub simulator). The underlying techniques extend the previous approach to include intrinsic motivations, dynamic movement primitives and reinforcement learning.

**Chapter 8** closes the thesis by summarising the main contributions of all experimental studies. The details of contribution to knowledge and a list of future work are also provided.

# Chapter 2

## Background on Mental Imagery

This chapter tends to point to the possible link between sensorimotor learning and other cognitive functions such as mental imagery, mental rotation and tool use. It gives a brief review on sensorimotor learning from the perspective of motor neuroscience. In particular, mental imagery is viewed as underlying by forward models in the motor areas of the brain. Literature reviews on mental imagery and example applications in robots are also provided.

### 2.1 Sensorimotor Learning

In the principles of sensorimotor learning (Wolpert, Diedrichsen, & Flanagan, 2011), there are three key elements that play an interactive role in the acquisition of new motor skills in humans, including components, processes, and representations of motor learning processes. These authors, first, pointed to the importance of underlying motor components in a way that, in order to learn new motor skills properly, one has to have basic components required to do so. For example, an ability to extract contextual information task-specific from sensory stream can be done only if one has a well developed visuo-motor system that controls movements of the eyes for saccading. This contextual information will be supplied to a decision making system to produce a response movement corresponding to the perceived sensory stream. The response movement is created with a different control mechanism, e.g., predictive, reactive, or bio-mechanical control. Second, the processes of motor learning are an error-based

process which consider the difference between actual and desired movements in the refining of the motor commands, or reinforcement learning which uses a scheme of rewards and punishments to guide the learning. Finally, in this framework, the representations of motor repertoire can be viewed as a combination of motor primitives, or the refinement of the whole motor repertoire through the processes of credit assignment which criticise the source (basic components) of motor error. Wolpert et al. also highlight the impact of conducting this kind of research in real-world situations increasing both the scale and complexity of the system.

Moreover, Krakauer and Mazzoni (2011) mention two different processes of the human sensorimotor learning, including motor adaptation and skill learning. The difference in motor performances is caused by the way humans weight these processes. The authors interpreted sensorimotor learning as the process of practicing sensory-guided motor behaviour that results in the improvement of the motor's performance. The studies of a goal-directed arm movement in humans include both low-level motor commands and high-level cognitive control. In addition, the authors provide a taxonomy for sensorimotor learning which mapped the proposed processes to specific brain areas. For example, the motor adaptation was linked to the cerebellum. The skill learning is linked to the prefrontal cortex, basal ganglia, and the motor cortex. There is an interplay between a sensory prediction unit and a forward model as an error-based paradigm. In contrast, the skill learning used success-based exploration to guide movements. The skill learning processes tend to reduce the error caused by the forward model that maps sensory data to motor commands. By feedback with this error to the forward model, its parameters can be modified through trial and error processes.

## 2.2 Internal models

The term “internal model” was defined by Wolpert and colleagues in 1995 as "a system that mimics the behaviour of a natural process" (Wolpert, Ghahramani, & Jordan, 1995: page 1880). This notion came from the idea that the central nervous system internally simulates the outcome of the motor system to support high order cognitive functions such as planning, motor control, and learning. In general, internal model involves two different kinds of prediction. The first internal model involves the forward model which produces the system's next state when given the current state, together with motor command. The latter is the inverse model, which does the opposite computation: when provided with a current state it generates corresponding motor command (see Figure 2.1).

Grush proposed the framework for information-processing named "the emulation theory of representation" (Grush, 2004). This was used to synthesise how the brain simulates and processes its internal representation of the body and environment. The framework applies forward models and kalman filters to form internal models. The internal models provide information about the body and environment to the brain. They emerge in parallel and use the same information about body and environment as of sensorimotor learning. The frameworks are able to address visual imagery, motor imagery, and planning capabilities which are developed by using the estimated outcome of different motor commands. The information provided by the forward models was used to simulate feedback input that can solve the problem of feedback delay in a physical control system. Grush claims that other cognitive functions such as reasoning, theory of mind and language can be synthesised by using this framework.

It is possible to do a mapping between motor neurons and the internal models (Miall, 2003). The idea was centred on the concept of mirror neurons in the ventral

premotor cortex of monkeys and in the posterior parietal cortex of humans. There are three different types of neurons in these areas that respond for visual inputs and actions. The first one is the neuron that codes visually guided actions. These neurons activated before and during actions performed by the monkey but not for the observed actions. The second one is canonical neurons that appeared to code for objects' affordance. The last one is the mirror neuron that codes both observed and executed actions. In monkeys, these neurons encode intended action on an object e.g., grasp for food. Miall suggests that forward models are the mapping from motor commands to the change of the environment. Instead, the inverse ones are mapping from visual input into the corresponding motor commands.

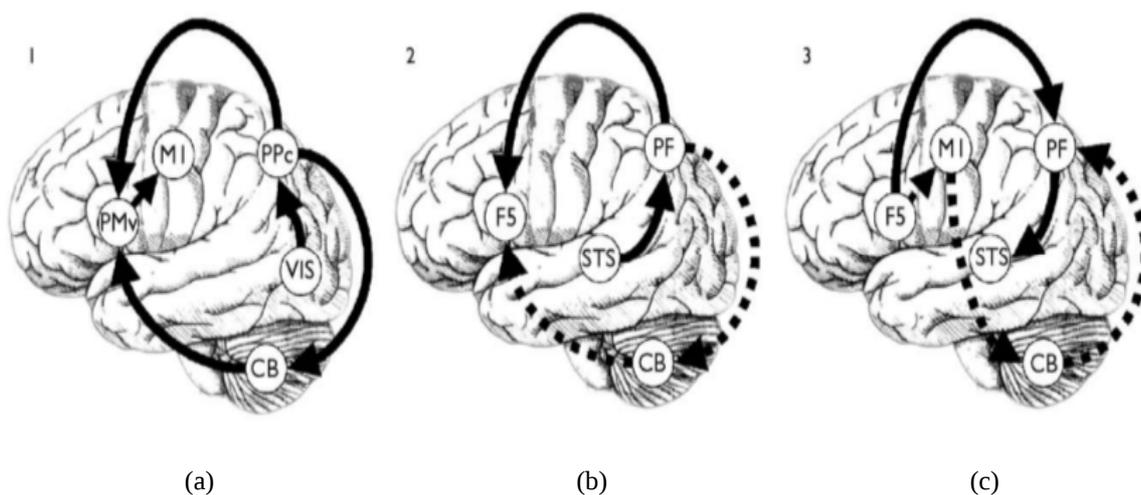

**Figure 2.1** A schematic diagram of pathways activated during three observations: (a) visually guide reach. (b) observation of action. (c) execution of imitated action (from Miall, 2003)

According to the schematic diagram proposed in Miall (2003), we interpreted mental imagery as possible through forward models e.g., the transformation of motor commands in F5 into the next state of visual consequence in PF, (see Figure 2.1c). The circuits shown in Figures 2.1a and 2.1b, illustrated a transformation of the visual perception into motor command. Thus, these indicate inverse models.

## **2.3 Mental Imagery in Psychology and Neuroscience**

Mental imagery is an internal representation of an experienced object that is formed in response to the perception of the objects' cue e.g., hearing or reading its name, seeing its shape. Mental imagery is viewed as simulated experience on objects which is possible from all sensory modalities such as visual, auditory and olfactory (Ganis, 2013).

Mental imagery concerns cognitive processes for the creation, inspection and manipulation of mental representation of objects or events (Paivio, 1969; de Borst et al., 2012). Alternatively, the term mental imagery is treated as the processes of re-elaboration and interpretation of perceived stimuli (Di Nuovo et al., 2014).

Mental imagery occurs in all sensory modalities. However, visual mental imagery is the most influential and well-studied case. There are a large number of neuro-imaging studies on mental imagery that target primarily the scenario related to the use of visual mental imagery (Ganis, 2013). Visual perception is the most powerful perceptual system that humans and animals use to explore their world. People experience their world based mainly on the use of visual exploration. Without visual mental imagery, we are not able to understand the world around us, since objects and events are normally folded (Ganis, 2013). Henceforth, the term mental imagery used in this chapter refers to visual mental imagery or mental images linking to the experience of seeing.

One important aspect of mental imagery is it occurs when there is no stimulus being perceived (Kosslyn, 1980). To be more precise, Kosslyn et al. (2006: page 4) defined mental imagery as "a mental image occurs when a representation of the type create during the initial phase of perception is presented but the stimulus is not actually being perceived; such representations preserve the perceptible properties of the stimulus and ultimately give rise to the subjective experience of perception." This definition refers to

re-experience or depiction of percept stimuli e.g., when people heard a named object. In order to answer questions related to known objects, the vast majority of human participants reported vividness of the objects in their mind's eye. For example, a vivid image of a German shepherd dog will appear in our mind if we are asked to observe the shape of its ears. Pictures of a pea and a tennis ball will appear if we are asked to differentiate between their size (Kosslyn, 1980). With these mental images, people can assess and determine the spatial properties of the objects in order to support other cognitive functions e.g., decision making. However, this view was attacked by propositional or verbal description of imagery (Pylyshyn, 1973), but it is not of interest here. Since this thesis treats mental imagery as images, and the two ideas (depictive, propositional) can be viewed as supplementary to each other to fulfil a form of human thought (Anderson, 1978).

The term mental imagery in this thesis refers to visual mental imagery, the re-experience of visual stimuli. This thesis concerns mental imagery in robots, however it is relatively difficult to construct mental imagery from other modalities. Like in humans, visual mental imagery is more easy to understand, since it is common that, the robots will perceive the world through their eyes (cameras) as much as humans.

According to Kosslyn (2006), mental imagery involves the use of long-term and working memory, since it is a process that simulates the experience of an object. When hearing a named of experienced objects, its relevant information will be retrieved and reconstructed in working memory as visual buffering.

There are common parts of the brain that activate in response to all mental imagery modalities, and specific parts that activate selectively depending on a specific type of imagery (Zvyagintsev, 2013). Behavioural data showed that the use of mental imagery will be impaired if one has damage to specific parts of the brain. These areas include

posterior left hemisphere which responsible for image generation (Farah, 1984).

Albers et al. (2013) suggest that early visual cortex (V1-V3) are required in both top-down as visual input processing, and bottom-up as mental imagery creation. In order to maintain and manipulate mental image in working memory, the visual cortex will be used as a "blackboard" which provides specific information about the mental items. In this study, one group of participants maintained visual working memory of visual stimuli, while another group were instructed to imagine objects. The authors found a similarity of the early visual cortex activation from the two groups when scanned the activity of brain by using fMRI technique.

Primary visual cortex (V1) is not always necessary for mental imagery (Moro et al., 2008). There are only some particular types of imagery that require precise, detailed imagery that are more likely to involve V1 (Bridge et al., 2012). According to Bridge et al. (2012), a patient with near-complete V1 damage was reported having vividness of visual mental imagery. The patient claimed that he could imagine house and face stimuli, but it was difficult to imagine a checkboard, the detailed stimulus. The neuroimaging data of this patient showed a spread of activation in parietal and frontal cortex instead of V1 when compared to normal subjects. The authors explained this data as the brain has some spare parts that can substitute V1. In this case these are the parietal and prefrontal areas.

Eye movements are commonly involved in visual perception. Oculomotor behaviour during mental image exploration and perception might be similar. The study conducted by Boursillon et al. (2011) tested this hypothesis. The study revealed that participants were asked to imagine a map of France and say that a given name (towns or regions) is located to the left or right of Paris. After that, the participants were shown the real map and asked again similar questions. In both cases, the participants' eye

movements were recorded. The results indicated that movements of the participants' eyes during the mental imagery condition resembles behaviour involved as in the case of visual exploration. The authors concluded that the mechanism involved in visual exploration might be shared with that of the search in visuo-spatial mental images.

This evidence supports the claim that visual mental imagery and visual cognition share some underlying processes. In addition, Ganis and colleagues (2004) reported that more than 90% of the cortical activations during visual perception is overlapped with that of during visual mental imagery.

Mental imagery also presents a topic of potential relevance to the field of clinical disorders. Pearson et al. (2013) focus on this point by providing a review of mental imagery measures and assessments in clinical disorders. From their review, there are four important stages of mental imagery that can be assessed in clinical research i.e., image generation, image maintenance, image inspection and image transformation. The four stages are also viewed as cognitive aspects of mental imagery. The review suggests that mental imagery is the main cause of much clinical disorder e.g., social phobia, schizophrenia, depression, post-traumatic stress disorder (PTSD), and bipolar disorder. However, other aspects such as working memory also take an effect in the disorder. The review also suggests that working memory is important in the study of clinical disorder. In order to conduct reliable measurements researcher should consider effects of working memory load that might involve in the study of stages of mental imagery. For example, in the assessment of bipolar disorder, instructions that require patients to maintain high working memory load may lead to the deficit of mental image creation which results in incorrectly identify causes of the disorder.

The important aspect suggested from this review is that mental “image generation” was found to be the cause of many disorders. Therefore, the potential treatment should

be conduct in order to correct the way patient generate mental image e.g., training to create positive mental images (prospective) of future events (cited in Pearson et al., 2012) in order to help patients with depression disorders.

In addition, the authors also propose a guiding framework for assessing the particular stage of mental imagery. They claim that their framework can help clinical psychologists to select the right measures and domains (mental imagery stages) for assessing the use of mental imagery for specific disorder experiment. The framework offers an opportunity to move forward the understanding of the role of mental imagery in clinical disorder. However, this review does not include research about the effect of brains' impairments and the clinical disorders, or the deficits of mental imagery.

## **2.4 Mental Imagery in Robots**

A few experiments have been conducted to demonstrate the use of mental imagery in robotic systems. Roy et al. (2004) interpreted mental imagery (mental model) in terms of physical simulation. In their study, a set of representations and procedures were used to maintain the mental model of object permanence for a conversation robot to use in situated spoken dialogue. The Open Dynamic Engine (ODE), a computer simulation for rigid body dynamics, was used to create mental images of current physical situations e.g., object in the scene. An idea of an object permanence in this work refers to the use of the ODE, physical simulation. The idea is that information provided by this simulation can be used to refer to objects, even they are out of the robot's sight. The robot and its human partner could talk about an out of sight object in their conversation. Despite this work mentioned about mental imagery, there is no discussion of how this simulation exists in the robot's cognitive or neural system.

Hoffmann (2007) demonstrate that a mobile robot together with a neural network

model can learn to anticipate a perception of spatial information of objects. Mental images of this work refer to the prediction (next step) of sensory inputs that were changed according to the control commands. After the robot is able to generate these mental images or sensorimotor information, it was tested with two tasks: distance estimation and recognizing a dead end. This work also applies a Gaussian Mixture Model to improve the quality of mental images created by the network. The results show that the model is able to predict a very similar number of steps (distance) required in order to move toward the obstacle comparing to the real movements. Secondly, the author claims that by using the predict visuomotor information obstacle avoidance behavior can be acquired by the robot. However, visuomotor of this work refer to the use of distance sensors, not visual information, thus, it serves as a cognitive (topology) map rather than visual mental imagery.

In relation to Piaget's theory of child development, Nishimoto and Tani (2009) demonstrate that the emergence of inner representation or mental imagery is possible through the processes of sensorimotor interaction. Motor imagery of this work restrict to the prediction (next state) of visuo-proprioceptive information of a miniature humanoid robot (SONY QRIO). Through the dynamic of multiple time scales neural networks (MTRNN, Yamashita & Tani (2008)) the task behavior (visuo-proprioceptive trajectories) can be imitated as joints' angle of the robot using topology preserve map (a population coding). The authors introduce tasks that require the robot to learn to acquire both primitive actions and actions sequencing in order to achieve goal-directed behaviors. The results show that feed-back from a forward model as a mental simulation of action can help the robot to generate equivalent goal-directed behaviors comparing to the use of physical interactions.

Mohan et al. (2011) introduce the idea of how a couple interaction between internal

models and actions generation of a cognitive architecture can generate goal-directed behavior for a robot. This work uses a mobile robot, GNOSYS, which is a 4 wheels robot with one articulated arm and a gripper, to manipulate objects within its working space. Mental imagery of this work refers to an ability to predict the outcome of actions as mental space which are derived from 3 types of forward (internal) models. The robot will always place in a playground environment, the task is to learn to grasp a ball from the different location in which some of them require an ability to use a tool or actions sequencing. The authors claim that, after successfully learn to generate spatial maps of the workspace as mental maps, the robot should be able to exploit the maps for identifying subgoals of one complex goal directed behavior. Despite this work is in its initial phase, it seeks to answer interesting questions e.g., how can the robot reduce/distribute a high level goal into temporally chunked atomic goals for the different internal models? what happens if the constraints in some environments do not allow the goal to be realized?

In robotic system, mental imagery can be interpreted as the result of actions that are simulated within a cognitive system of a robot. Kaiser and colleagues (2010) proposed a model architecture that predicts a visual sensory change according to the change of the robot's posture and its current visual field. Their model consisted of a chain of forward model like architecture, with feed forward neural networks, together with a principle component analysis (PCA) module. This endows the model with a capability of visual prediction, in which a new motor command can generate the prediction change of a robot's gripper.

Di Nuovo et al. (2013) proposed a neural network model capable of self-generating a training set. This work took inspiration from a concept of mental practice in sport science. The model has two sub networks within a modular architecture, a feed forward

network for controlling a robot, and a recurrent network for generating predicted outcome that was used in a mental simulation process. The two networks were trained in parallel and used the same inputs. The key idea is that output from the recurrent network will be used as additional output for training the feed-forward network. The authors called this scheme “simulated mental practice”. The task is to control the simulation of a humanoid robot which learns to throw a ball a given distance. The model collects an initial training set from 25 samples of throwing with different velocities. The result showed that the robot's throwing performance improves with an additional training set provided by the self-generated network.

Based on an inspiration that animals form “cognitive maps” and use them to plan possible actions in navigation tasks rather than following stimulus-response paradigm. Chersi and coworker (2013) propose a biologically realistic model that explain the way mental simulation can be applied in a spatial navigation problem. The model consists of three main components: the hippocampus which is a collection of neurons replicating place cells, the ventral striatum, and the sensory-motor cortex. The task is to control a virtual rat (in a computer simulation) to explore a complex maze in order to find rewards e.g., cheese, water. The cognitive maps are formed within the hippocampus and modulated by spatial and sensory information. The idea is that the cognitive maps can also be modulated by mental simulation of actions. Since, the cognitive maps and sensory states are used in the processes of action selection, therefore, thus the action can be varied based on motor imagery. The result shows that the simulated rat can navigate through the maze and be able to find the rewards.

## **2.5 Mental Rotation**

Mental rotation, first described by Shepard and Metzler (1971), has attracted enormous

research interest in the field of cognitive psychology. This is in part due to the attempts to understand why object comparison using imagery seems to obey the same physical principles as overt rotation, considering that humans are capable of using imagery that is not limited by the laws of physics (Kosslyn, 1996).

In a typical mental rotation experiment of cognitive psychology, a participant has to mentally rotate an object perceived in a picture to decide if it is the same as a target object or different from it (i.e. a flipped version of it), and then indicate the answer by pressing one of two buttons (Shepard & Metzler, 1971; Wexler, Kosslyn, & Berthoz, 1998). In this kind of task, participants normally report that in order to make the decision they mentally rotate one object, clock-wise or counter clock-wise, until it visually matches or mismatches the target object. The actual existence of this process is supported by the main result of mental rotation experiments: the reaction time to press one of the two buttons, and the error rate of the answers, increase with the angular disparity between the rotated object and the target object. Mental rotation has been widely investigated not only in cognitive psychology, but also in cognitive neuroscience and computational modelling (Kosslyn, 1996; Zacks, 2008). Initially, it was proposed that the brain mechanisms underlying mental rotation mainly involve visual and spatial perception systems (Shepard & Metzler, 1971; Corballis & McLaren, 1982). More recently, behavioural (Wexler, Kosslyn, & Berthoz, 1998; Wohlschläger, 2001) and neuroscientific experiments (Georgopoulos et al., 1989; Lamm et al., 2007) have suggested the idea that mental rotation relies on a mentally simulated action (Michelon, Vettel, & Zacks, 2006) rather than on a purely visual and spatial imagery skill. Brain-imaging evidence on the brain areas most involved in mental rotation support the idea that mental rotation indeed depends on a strong integration of sensorimotor processes and covert mental simulation of motor movements.

Early attempts to explain brain mechanisms underlying mental rotation processes relied upon a visuo-spatial perception hypothesis (Shepard & Metzler, 1971; Corballis & McLaren, 1982). According to this view, mental rotation is performed on the basis of processes mainly involving the internal manipulation of the visual and spatial features of objects. This view makes the prediction that these processes mainly implicate brain areas underlying visual and spatial perception. Contrary to this, recent behavioural and neuroscientific evidence also indicates an important involvement of motor processes, beside the perceptual ones. In this respect, several behavioural works show interference between action planning/execution, and mental rotation processes (Wexler, Kosslyn, & Berthoz, 1998; Wohlschläger & Wohlschläger, 1998; Wohlschläger, 2001). In a typical experiment participants are asked to perform a classical mental rotation task (Shepard & Metzler, 1971) while performing a manual rotation on a custom joystick in both congruent and incongruent conditions, with respect to the direction of rotation of the mental image. The results show that RTs (and error rates) are faster (lower) when the direction of the two rotations (manual and mental) is congruent, whereas they are slower (higher) when they are inconsistent (Wexler, Kosslyn, & Berthoz, 1998; Wohlschläger, 2001). This supports the idea that motor processes play a key role in mental rotation, as otherwise it would be difficult to explain why the production of overt motor actions interferes with mental rotation only when the two are incongruent.

Single cell recordings in the motor cortices of monkeys also supplies direct neural evidence for the involvement of motor processes in mental rotation (Georgopoulos et al., 1989). In humans, a number of neuroscientific studies using different research techniques, such as transcranial magnetic stimulation (TMS), event-related potentials (ERPs), and functional magnetic resonance imaging (fMRI), show an involvement of lateral and medial premotor areas (lateral premotor cortex/precentral gyrus and

supplementary motor area) during mental rotation (Lamm et al., 2007; Richter et al., 2000). The fMRI study of Richter and colleagues (Richter et al., 2000), for example, shows a significant correlation between the hemodynamic response in lateral premotor areas with the response time of participants involved in the classical Shepard and Metzler mental rotation task (Shepard & Metzler, 1971). This result suggests that mental rotation is an imagined (covert) object rotation action rather than an image transformation relying exclusively upon visuo-spatial processing. This claim has been further confirmed by other studies (cf. Wohlschläger, 2001; Lamm et al., 2007; Lamm, Fischmeister, & Bauer, 2005).

Importantly, despite these consistent results about the involvement of motor processes during mental rotation, we still lack a comprehensive hypothesis of the specific brain mechanisms involving motor simulation that might underlie mental rotation processes. One proposal that might help to explain the role of premotor areas during mental rotation pivots on the concept of affordance (Gibson, 1986) and its behavioural manifestations (Tucker & Ellis, 2001), brain correlates (Rizzolatti & Craighero, 2004), and models (Caligiore et al., 2010; Fagg & Arbib, 1998). According to this perspective, affordances are the possible actions that objects and the environment offer to a certain agent. In particular, the visual presentation of objects triggers the activation of internal representations (the representations of affordances) needed for the on-line guidance of actions over them, within the parietal-premotor circuits (Grafton et al., 1996; Grèzes & Decety, 2001). In this respect, the activation of affordance representations might be involved in the mental rotation processes, as in-brain it plays a key role in the first stage of motor preparation.

According to the mental rotation experiments in human children studies, a traditional finding indicates that the link between motor performance and mental

rotation are more pronounced in children than in adults. However, the empirical study by Krüker and Krist (2009) showed the opposite results, i.e., the motor process was less pronounced in the participants aged 5-6 years, whilst it became stronger in 7 year old children and adults. This suggests that motor processes and mental images are linked. The link becomes increasingly stronger through the experience of object manipulation during life which results in improvements in the performance of mental rotations or even the prediction of object movements in space. The speed of mental rotation also depends on age and improves with development (Kail, Pellegrino, & Carter, 1980).

Another hypothesis on how motor areas might participate in mental rotation comes from neuroscience theories (Grush, 2004), neuroscientific evidence (Miall, 2003), and computational architectures (Wolpert & Kawato, 1998) on motor control based on forward models. This perspective suggests that preparatory/planning covert motor processes play a key role in the mental simulation and understanding of the environment. The same brain motor areas are involved in overt action execution. This view would suggest that mental rotation involves the same motor areas and mechanisms used in the physical execution of active rotations of objects (e.g., manual rotations), and the imagined anticipation of their sensory consequences.

Both views would give important indications on the possible involvement of motor areas in mental rotation phenomena. Wexler and colleagues (Wexler, Kosslyn, & Berthoz, 1998) stated the hypotheses that “transformations of mental image are at least in part guided by motor processes.” (Wexler, Kosslyn, & Berthoz, 1998, page 77). This view also supports the existence of a relationship between affordance learning (motor processes) and forward model (mental image). The dual task paradigm (Kosslyn, 1996) is the best example that supports the view of shared location between motor processes and mental rotations in motor cortex. Affordances can be generated from the initial

configuration of a body, in terms of motor commands, by a forward model on the basis of a goal-related information (Thill et al., 2013). However, both views would still be limited. In that mental rotation is a complex process which requires the coordinated operation of several distinct elemental cognitive processes. These processes include (Lamm et al., 2007) (a) stimulus encoding and mental image generation, (b) planning and execution of the mental rotation, (c) comparison (matching) of the rotated stimulus with the target stimulus, and finally (d) execution of the same/different response.

### 2.5.1 Brain areas and neural mechanisms involved in mental rotation

Various areas of the human brain have been shown to be involved in mental rotation through functional magnetic resonance imaging (fMRI) techniques. A meta-review (Zacks, 2008) summarises the main areas that several studies have found to play a relevant role (Figure 2.2).

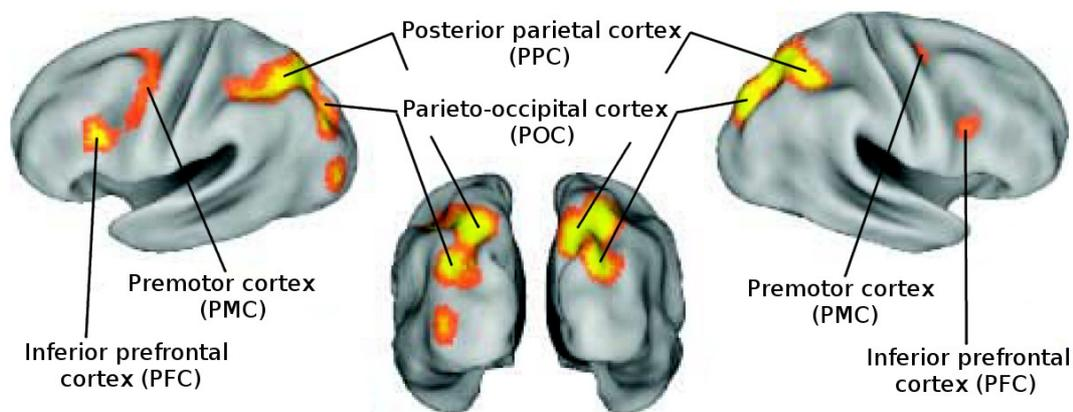

**Figure 2.2** The key brain areas involved in mental rotation and considered in the model. The green-yellow coloring highlights increasingly active areas. Left: brain lateral left hemisphere. Centre: posterior brain view. Right: brain lateral right hemisphere.

Most brain imaging studies scanning the human brain during the performance of the mental rotation task show a prominent activity of the posterior parietal cortex and

posterior-occipital cortex. In particular, the areas around the intraparietal sulcus (more specifically, the superior parietal lobule, Brodman Area BA7, and the inferior parietal lobule, BA 40), and the areas surrounding the parieto-occipital sulcus (parieto-occipital arcus, BA 19) (Carpenter et al., 1999; Harris & Miniussi, 2003; see Zacks, 2008, for a review). The activity of some of these areas also correlates with the amount of mental rotation requested in the different task trials and dependent on the object-target orientation disparity. Posterior parietal cortex receives input related to both visual and somatosensory information (Rizzolatti, Luppino, & Matelli, 1998), and on this basis it is capable of elaborating information about the location and orientation of target objects in peripersonal and extrapersonal space, and their relation to own body (Andersen & Bruneo, 2002; Colby & Goldberg, 1999), in large part employing eye-centred coordinate frames modulated by own body postures (Snyder et al., 1998). Posterior-occipital cortex includes high-level visual areas encoding complex visual features, in particular related to movement (e.g., involving global and own movement, Braddick et al., 2001). Based on this evidence, these areas are thought to play a key role in implementing the proprioceptive and visual information integration and transformation supporting the core processes of the dynamic mental rotation processes (Zacks, 2008).

Other brain regions that consistently activate during the mental rotation experiment involve the supplementary motor area and the premotor cortex, in particular involving the medial precentral gyrus (BA6) (Johnston et al., 2004; Cohen & Bookheimer, 1994; Lamm et al., 2007; Zacks, 2008). These areas encode a repertoire of actions at a more abstract level with respect to primary motor cortex, and play important functions in motor planning and execution (Jeannerod et al., 1995). The activation of these areas strongly supports the involvement of motor processes in mental rotation, putatively to implement motor mental simulation. This possibility is corroborated by the fact that the

supplementary motor area has been strongly involved in motor imagery (Stephan et al., 1995). Some studies also reveal an activation of primary motor areas, primarily linked to the production of the final response (button press) rather than to the main mental simulation processes (Richter et al., 2000).

Kosslyn et al. (1998) and Zacks (2008) have also shown the activation of prefrontal areas, in particular the inferior lateral prefrontal cortex (inferior precentral sulcus, BA44/45). This region, part of Broca's area responsible for speech production, is involved in motor production and action recognition (Rizzolatti et al., 1996). Given its high-level within the motor hierarchy, this area might orchestrate mental rotation at a high-level, as suggested by its role in motor imaging (Grafton et al., 1996).

Several components of the model are formed by neural maps using, in specific or abstract ways, *population codes*. Neural maps are suitable to model cortical areas as they capture their important 2D topological organisation and also facilitate the analysis and visualisation of the processes occurring within them (Caligiore et al., 2014). Population codes (Pouget, Dayan, & Zemel, 2003) are based on the idea that information (on stimuli and actions) is encoded in the brain on the basis of the activation of populations of units, organized in neural maps having a broad response field. In particular, each unit responds maximally to a certain value of the variables to encode and then progressively less intensely to more distant values. This response can be obtained with short-lateral excitatory connections and long-lateral inhibitory connections, or in a more abstract fashion (as for most maps) with Gaussian functions.

To implement the decision making process involved in the mental rotation task, the model uses a *mutual inhibition model* (Usher & McClelland, 2001; Bogacz et al., 2006). In this model (closely related to the architecture and neural competition that can be implemented by population-code maps) different decision options are represented by

neural units that accumulate over time the evidence (support) on the goodness of the different options, compete through reciprocal inhibitory connections of the units, and finally produce a decision when the activation of one of them reaches a given threshold. This model (together with other analogous models, e.g. Bogacz et al., 2006) is very important, as it allows the reproduction of the reaction times often recorded in psychological experiments (Erlhagen & Schöner, 2002; Caligiore et al., 2010; Caligiore et al., 2008). It is one of the most accredited models of decision making processes taking place in the human brain (Bogacz, 2007).

In the brain, several processes needed to acquire and express mental rotation (e.g., learning from experience, and selection of cortical contents) are putatively implemented by cortical areas working in close cooperation with sub-cortical regions, in particular basal ganglia and cerebellum with whom they form whole integrated systems (Alexander, DeLong, & Strick, 1986; Middleton & Strick, 2000; Caligiore et al., 2013; Baldassarre, Caligiore, & Mannella, 2013). For simplicity, the model reproduces in abstract ways such processes, e.g. to implement the decision making processes and the mapping of the object representations to the corresponding arm postures, without explicitly simulating these sub-cortical systems.

## **2.6 Mental Rotation Models**

Surprisingly, there are only a small numbers of papers concerning the replication of mental rotation in a computation model. Most of them focused on rotation invariant and object recognition by using neural networks (e.g., Kulkarni, Yap & Byars, 1990; Fukumi et al., 1992; Fukumi, Omatu, & Nishikawa, 1997; Rowley, Baluja & Kanade, 1998). In relation to our work, Sasama et al. (2009) proposed a back-propagation neural network model of mental rotation. Their model is a three layer neural network that takes

two images as inputs and produces one binary vector as outputs. The task is to report the angular difference between the two input images together with a response answer (match/mismatch). By definition, this is acceptable as a characteristic of mental rotation tasks. The images used in a training set are a pair of 2D image maps size 13x13 pixels. Each image can be a version of alphabet letter or a random image. In the training period, each pixel of the two images will be fed as input values (range 0.0 - 1.0) into the network, while the output will be a desired disparity between the two images. By using back-propagation learning, the network can create an association between the two inputs and its disparity.

Inui & Ashizawa (2010) proposed a computational neuroscience model for 3D mental rotation. They leverage related regions of the brain that are responsible for mental rotation and object recognition into connected subsystems. The model consists of three main parts i.e., parietal network, temporal network and visual cortex. The task is to compare the two 3D objects (each one is two connected lines) and to create a new mental image. A radial basis function (RBF) neural network was used to underlie a comparison process in the temporal network. The two stick-like objects will be fed to the visual cortex as perceived image. One is a target object which will be stored in a memory, while another one is for rotation. The RBF network was trained to generate a level of matching between the two objects. When the level of matching is low, it triggers the parietal network to send a rotation command to the visual cortex. The direction of rotation was guided by the rotation command, and the new image will be regenerated internally in the visual cortex. The new image will be fed to the temporal network again as a continuing step in mental rotation. On the other hand, if the level of matching is high it indicates that the disparity between the two objects is small. In more detail, each cycle of repeating image rotation processes, the level of matching gradually increases.

The rotation will stop when the level of matching is high enough and reaches a threshold value of a gating network. The gating network acts as a cut off circuit in the model that, the authors claimed, replicates the characteristic of inhibition signals from the temporal network to depress neurons' activity in the parietal network. This work shows that the rotation cycle depends on the angular different between the two objects.

The last two works reviewed in this section provide insight into the possibility of creating mental rotation by means of computational modelling. Unfortunately, there is no image rotation process in Sasama et al. (2009), and there is a lack of any further information about response times, in both papers.

## **2.7 A Comprehension of Infants' Tool Use**

An ability to use a tool in human infants was found at different age, due to the nature of individual differences or causal cognition. However, significant evidence indicates that infants appeared to start and master their knowledge regards tool using, at the period of 8 to 24 months, the sensorimotor stage 4 to 6 (Piaget, 1952; McCarty, Clifton, & Collard, 2001).

The mechanism which drives infants to play with objects or to explore their body is believed to be the case of intrinsic motivations (Ryan & Deci, 2000), and the benefit that play gives to the infants is the acquiring of knowledge about their body and the world. This is a cyclical process, in which motivation drives action, actions cause changing in the infants' perceptual space and those changes will, for example, trigger the motivations such as fun or surprise. There are at least two different views with regards to a motivation system. The first view is a motivation as rewarding scheme (Oudeyer & Kaplan, 2007). This is done by considering that there are critics inside and outside of an agent which generate rewards. If the critic acts outside the agent, this will

be called extrinsic motivation. In contrast, if the critic is inside the agent, the reward is considered as self-generated. This is an intrinsic motivation system. The second view is a motivation as a driving force (Schlesinger, 2013). There is no critic in this scheme. The rewards are determined by the agent itself. This motivation can be viewed as neural activation which is kept on activating when preferred situation occurred, and will be depressed when nothing interesting happens or practiced actions have been mastered.

Schlesinger and Langer (1999) pointed to important evidence regarding infants' developing tool use actions and expectation. Infants exhibit tool use behaviours at an early age and these actions develop through developmental stages from subjective to objective (subjective, transitional and objective). When an infant was in the subjective state of tool use, it cannot solve a given tool use problem due to the lack of required action (i.e., pulling). Because, this is a beginning stage, the pulling action has not developed yet. Infants at this stage may instead play with the tool, or ignore it and try to reach for the toy with their hands. The second stage is transitional. At this stage infants can use the tool to retrieve the goal object but they exhibit the same action in both cases of tool use events (i.e., contact or noncontact). Therefore, it seems likely that a spatial relation between the tool and goal object does not affect the infants' action selection. Finally, infants at the objective stage solve the tool use problem properly. They can shift to use other strategies (e.g., offer the tool to the experimenter) if they do not know how to retrieve the toy in the case of non-contact. These three stages of tool use actions reflect individual difference in infants' tool use performance. In addition to tool use actions, infants also observe the outcome of a currently perform action through visual perception. These processes, later, can be used to form an ability of expectation. The infants can distinguish the difference between possible and impossible tool use events through the practice of this observation. This study restricted tool use problem to relying

only on pulling action, but put more focus on the infants' expectation on the tool use events. It used two types of tool use problems including supporting and surrounding. The case of supporting refers to the use of a rectangular cloth as tool. The case of surrounding was a hook that used as tool to retrieve the object. The difference in the tasks that used cloth or hook, can be determined easily by the infant due to the big difference in their appearance. The evidence shows that, at an early age, infants spontaneously pull tablecloths, blankets in order to reach a goal object. Therefore, it is possible to claim that supporting tool use actions are developed before surrounding. The expectation of actions outcome can be viewed as the use of mental imagery in young infants.

The problem of tool use in human infants during the period from 8 to 24 months is highly dependant on the condition of spatial gap between the tool and toy. All infant participants can succeed in the retrieving when the tool and the toy are connected (Rat-Fischer et al., 2012). The point is that only older infants can achieve the case of large spatial gap. As suggested by psychologists, the full understanding of how to use tool starts at the age around 18 months.

In the experiment on infants' tool use development conducted by Rat-Fischer et al. (2012), infants aged 14 to 22 months were tasked to retrieve an out-of-reach toy put on a table using a provided rake-like tool. The aim of this study is to examine how tool use understandings in infants develop with age. The authors suggested that the infants start to have this knowledge on reaching 18 months of age. The key difficulty in this kind of tool use is the spatial relation between the tool and the toy. All infants can successfully retrieve the toy and the tool when they are physically connected. The success rate varied when the spatial gap between the two objects increased. However, in this study, only the condition of large spatial gap, tool in hand, that truly reflect the understanding of tool use in infants. In addition, by providing a demonstration session to infants that fail to

solve the task, the infants can benefit from the demonstration indicated by the spontaneous success on a further test, but this happen only in the infants aged 18 months and older. This suggests that observation of a tool use demonstration can fulfil the sensorimotor experience of the infants, but it appears that this benefit only happens when the infant has initial knowledge of how to use tool. It is worth noting that at the age of older than 24 months, the infants have no problem in solving a tool use task with large spatial gap.

In Lockman (2000), banging movements or instrumental hammering produced by infants during the second half year of age are interpreted as practice of the actions they have learnt, in order to initially distract their perception, effect their world, and drive sensorimotor learning. In this view, tool use is possible through the processes of perception-action routines. A tool causes change to a contact object and the infants use this to explore their environment.

## **2.8 Tool Use in Robots**

Stoytchev (2005) applied a behavior-based approach to fill-in an affordance table which will be used as action repertoire for a robot. New entries to the table will be added when an observation function detects interesting events (e.g., an attractor was moving). Affordances in this work refer to the differences in an objects' parameters (e.g., colour code, positions in 3D coordinates) and the outcome of each performed action. The robotic system is a wheel-based mobile robot with a manipulator arm and a gripper, on top of it. The task is to use a given stick, by grasping its handle with a gripper, as a tool to move an out-of-reach object (i.e., a hockey puck) to specific locations on a table top. This work is one of only a few robotic studies that tend to demonstrate tool use competence in robots. The action selection was simply searching on a look-up table, as

there is no evidence of other cognitive functions involved during exploration, learning, and testing phases. Furthermore, the vision system of this model was remote to the robot (a camera was fixed on a ceiling). Thus, it is difficult to follow that the robot acquires affordance knowledge by itself, considering that images taken from the remote camera are much different from the usual view of the robot itself.

In term of action simulation and action selection, Schillaci et al. (2012) demonstrated the use of inverse-forward models to underlie reaching movements in a humanoid robot. Based on forward models as predictors, the robot can select proper arm movement in order to minimise the distance between end-point of the hands and a target position in space. Note that, the left hand of the robot was attached with tool, so the end-point of the two arms are difference.

Tikhanoff et al. (2013) demonstrate another example of tool use ability in the iCub robot. This work shows that the robot can select different tools corresponding to the affordance of an object it is going to manipulate. Affordance of objects in this work refer to the angular difference between the selected tool and a toy. The tool use scenario is an object retrieval task, in which a toy will be placed far from the robot at different locations on a table with two types of tool provided i.e., the rake and the hoe. The robot will choose different tools depending on the position of the toy that directly affects its affordance. However, this work primary focuses on tool use applications and underlying components from a roboticist point of view, there is no focus or an understanding of tool use ability with respect to psychology literature.

# Chapter 3

## Background on Cognitive Robotics and Neurorobotics

### 3.1 Introduction

Robots are commonly acknowledged as a hardware system that typically consist of sensors, actuators, processors, and control mechanisms. Indeed, robots are also perceived as an artefact that is able to do some pre-defined actions corresponding to its perceived information.

A robot is a tool invented by humans to perform unwanted tasks for humans (Rahimi & Karwowski, 1992). What separates robots from other artefacts is their special characteristics in terms of senses, processes, and acts. Robots can move their parts to do their tasks, for example robotic arms or manipulators in industrial manufacturing (Siegwart, Nourbakhsh, & Scaramuzza, 2011). Robots are programmed to perform some specific tasks and follow each step of a fixed instruction unquestioningly. That is good in terms of accuracy for a simple routine task, while it lacks flexibility and adaptability for a complex (for robots) task, unlike the way living things have done to perform their tasks.

In order to make a robot smart, its body must be taken into consideration, because most of the necessary equipment in a robotic system is installed in the body. The design of the robot's body must concentrate on the task that robots will perform and most of the robot designers tend to make it as suitable as possible. In other words, the good design of the robot's body would give the robot an efficient ability in working and moving through the use of well designed mechanical structures, actuators and materials.

Robotic scientists mainly optimise their robots to include intelligent capabilities. In particular, some robots were designed to work in the real environment (Siegwart, Nourbakhsh, & Scaramuzza, 2011) and therefore in order to sense the world, they require sensors to be their senses. A well-designed robot's body should provide an optimal place and space to install the number of sensors needed in their task. In addition there are many sensor types that could be used in robots to measure surrounding properties such as light sensor, range sensor, temperature, direction and inclination sensor. The robot designer can install many of the sensors in their robot if it necessary. Furthermore, an image processing module is one of sensors that acts as a visual perception in animals (Horn, 1986; Vernon, 1991), by using digital cameras instead of biological eyes. The visual perception or seeing is very useful and helpful to animals because it is a long range sensor and helps the animal to understand the whole of the current the situation they face. The current performance of the image processing module is still far from the visual perception system in animals. However, many scientists/engineers are undertaking research in the field of visual perception and have often reported a good progression (Azad, 2009). Therefore an ability of a robot to see would be achieved, if the researcher found the right way to create a powerful image processing module.

### **3.2 Cognitive Robotics and Neurorobotics**

The current perspective on AI and robots concerns intelligence that derived from having body, not by the knowledge of a roboticist (Asada et al., 2001; Pfeifer & Bongard, 2006).

A major limitation of the traditional pre-programmed robots is adaptability, despite having limited in-built intelligence. Robots often encounter tasks that require real-time

reactions according to the current states of the environment and itself. The accuracy of action selections depends on the level of accuracy of its internal representations. However, the real world is complex and it is therefore extremely hard or impossible to collect and store all possible situations that the robots will face in advance (Schaal, 1999; Weng, 2004). Consequently, most robots fail, when dealing with unpredictable dynamic environments. The role of cognitive control integrated with the concept of embodiment, might offer robotic scientists an improved approach to implement adaptive capability into their robots, in which it might fulfil the gap through mechanisms underlying the learning processes.

In robots, the concept of embodied cognition offers a promising way for constructing true intelligence, by replicating the way humans acquire their knowledge into robotic platforms. Following this direction seems convincing to make robots acquire knowledge, through their bodies, brains and interaction with their environment.

Brain-inspired mechanisms have been considered as an important aspect in cognitive architectures, since many researchers claimed that it is well suited to adaptive controllers. The review also follows the perspective of embodied cognition and focuses mainly on cognitive robotics/architectures that are contributed in the development.

### **3.2.1 Cognitive Robotics**

Cognition means "faculty of knowing" in Latin (Purves et al., 2013). To develop an artefact housing the same ability of "knowing" akin to human beings is fundamentally challenging. Cognitive robotics refers to a research program within the field of robotics, that aims to construct autonomous systems emphasising levels of human cognition as appropriate responses. Cognitive robotics is a multi-disciplinary research area underpinned by a number of fields such as computational neuroscience, cognitive

science, artificial intelligence, developmental psychology, to name but a few (Asada et al., 2009; Dominey & Warneken, 2011). Indeed, the overarching goal of cognitive robotics is to advance the understanding of human cognition (D'Mello & Franklin, 2011; Krichmar, 2012) through the use of bio-inspired mechanisms in designing artificial cognitive systems (Cangelosi, 2010), and building robotic agents capable of acquiring and representing different forms of human cognitive phenomena such as perception, sensorimotor coordination, categorization, language, memory, thought and learning (Cangelosi, 2010). The contribution of cognitive robotics is a synthetic approach to science, especially developed to demonstrate the reality of natural intelligence, by dedicating itself as tools for proving cognitive hypotheses.

The extent of the term cognition, high level cognition, or human cognition is hard to define. Indeed, "Cognitive Robotics" has different meanings to different individuals and communities and as such this topic has been researched in different directions and research methods. In contrast, others might concentrate on embodied cognition underlined by the concept of embodiment, which is based on the interaction between robots and their environments. Cognitive robots are also widely used to investigate cognition by means of an embodied computational model (Metta & Cangelosi, 2011). D'Mello and Franklin (2011) have pointed to the necessity of using cognitive robotics to fulfil the extent of computational models of cognition. Indeed, the authors state that computational architectures such as SOAR, and ACT-R are useful to simulate some forms of human cognition with related mechanisms of the human brain. However, these models lack the reality of senses and actions. In this context, using a cognitive model and connecting to cognitive robots could extend the understanding of cognition.

### 3.2.2 Neurorobotics

While cognitive robotics considers embedding cognitive abilities into robots, neurorobotics focuses on a more specific research direction. This is concerned with the replication of neural network characteristics as control mechanisms to drive robots' behaviours and a greater focus on embodied autonomous systems. Neurorobots can be used to test and prove brain models designed by neuroscientists. The following three contributions directly apply to the field of neurorobotics: neural network based or brain-inspired mechanisms, autonomy, and embodiment (Kaplan, 2008). Neural networks have a long standing contribution to the study of neural processing in the brain. From multi-layer perceptron to spiking neural networks and to biological neural networks, there is a large number of proposed models in the field of artificial intelligence and brain-inspired intelligence. However, contributions in the field of neurobotics are relatively sparse. A large body of research has explored various ways to produce suitable control systems for the neurorobots. For example, Bouganis and Shanahan (2010) studied sensorimotor learning, otherwise known as motor babbling, in a humanoid robot (the iCub) through the use of neural network based techniques. They prepare a neural network control model with spiking neurons. A Spike Timing Dependent Plasticity (STDP) mechanism was used to adjust the weight vectors of the model, during a period of motor babbling (learning). The experiment aimed to move an arm of the iCub approaching to specific positions in space autonomously, by providing visual information and joint angles of the robot as inputs to the model. This work is an illustration of the use of three key contributions in the field of neurorobotics as the robot acquired the sensorimotor knowledge using motor babbling procedures.

From findings from the related fields that study human cognition such as neuroscience, cognitive science, and developmental psychology, Tikhanoff, Cangelosi

and Metta (2011) demonstrated the use of a humanoid robot simulation as a developmental neurorobotics platform in performing and acquiring cognitive abilities in an adaptive manner. Their study used neural networks and a collection of training sets to form a number of models of cognitive abilities. By teaching the robot through an embodiment strategy, this work demonstrated that the robot can manipulate objects both autonomously and adaptively as well as understand a human's utterance instructions. Interaction with objects, environment and an instructor in training periods underlies the success of this work. There are three main tasks that the authors used to teach the robot: learning to reach, learning to grasp, and learning to integrate speech and action. In the first training, learning to reach, a feed-forward neural network was used to associate a relationship between objects' position in space (x, y, z coordination) and specific joints' angle of the right arm of the robot. This training tends to replicate a human-like reaching, based on a technique of visuo-motor interaction. After training, the robot can recognise the position of an object in a stationary space and is able to reach to the position. In the second experiment, learning to grasp it is more complex than the previous experiment, since grasping for an object required a sequence of actions. The authors applied a recurrent neural network to the control architecture as the outputs from the previous step which would be fed back to the supplied inputs of the network. This scheme provides an additional input or memory of a previous action to the network. Grasping for an object is a crucial aspect when a robot has to manipulate it. This experiment continues from reaching using separated networks, when the robot has successfully reached to a specific position that an object is placed, then it starts to grasp. In the last experiment, the robot is required to learn to manipulate an object according to human instructions and its visual perception. The visual input of a seen object will be mapped to a speech signal that identifies object's properties such as colours and shapes.

The control architecture of this experiment also uses a feed-forward neural network to which its' outputs are connected to the two networks of the previous experiments. The instructions used in this experiment consist of the combination of an action and specific object properties such as, reach blue ball, grasp red ball and drop green cube into basket. Indeed, this work provides the model description that underpins an idea of learning through action manipulation or embodiment. The authors also proposed that the robot can understand human instruction but is restricted by an initial vocabulary. The combination of action-object-name in the last experiment shows that the model is able to replicate the way children learn speech from sound. This work fully demonstrates the use of neural networks to create human-like cognitive abilities in robot platforms.

Alnajjar et al. (2013) demonstrate the construction of a neural network model of working memory to handle cognitive tasks in a SONY humanoid robot. Cognitive tasks, such as cognitive branching and switching were defined as processes that needed higher-order cognitive mechanisms in the frontal lobe. A working memory was formed using a hierarchical model of Multi-Timescale Recurrent Neural Network (MTRNN). The basic idea underlying this type of neural network is that not only determining the distance between nodes in neural space but also the types of neurons and its difference time properties. Moreover, the working memory is formed within a hierarchy of context neurons. Through using working memory, the authors show that the robot can reproduce sequences of learned tasks (to move its index finger pointing to specific positions in sequence). Indeed, after performance of some interrupting tasks assigned by a human instructor, the robot can resume to continue and complete its previous task (after a thorough learning trial). In addition, by varying the number of learning trials, the model can acquire two types of memory: static and dynamic. The two types of memory show significant differences in memory encoding capacity in context layers. The authors

theorised that, their work has the potential to scale up to obtain various kinds of higher-order cognitive mechanisms. This work provides an insight into the possibility of mimicking a biologically similar working memory in humanoid robots.

Caligiore et al. (2008) propose a neural network model of affordances and compatibility effects. This work is based on evidence from behavioural and neuroimaging that illustrates that perceiving objects activates related motor areas (affordances). Signals from the prefrontal cortex as top-down bias signal will compete with bottom-up signals, from affordances. In this theory, when the two signals are different, for example, a participant was asked to form precision grip on a showing of large object, in this case a response time will be larger (slower). Indeed, a precision grip is compatible with small or natural objects while a power grasp is for large or artefact objects. This work replicates the compatibility effect in a robotic platform. A simulation of a robotic arm was used as a simulated participant. The task is to control the robot arm reaching and grasping for different objects. The neural network model comprises of several neural maps that are formed by population coding. Two routes of information processing (i.e., dorsal and ventral pathway) were simulated by incorporating related areas in the prefrontal and visual cortex. Through the use of the dynamic-field competitive processes which considers the time used to form a most salient cluster activity in the neural maps, this model can also produce a simulated response time. The result showed that the model can reproduce the experimental result of Tucker and Ellis (2001). This work contributes to the model of brain-inspired mechanisms which has demonstrated an ability to replicate the cognitive processes in the brain.

Cangelosi and collaborators (Cangelosi & Riga, 2006; Tikhanoff, Cangelosi & Metta, 2010; Peniak et al., 2011) have demonstrated the use of various neural network techniques such as back-propagation (BP), Hebbian learning, Kohonen competitive

learning, back-propagation through time (BPTT) and multi-timescale recurrent neural networks (MTRNN) to underpin notions of self-generated cognitive acquisition in both robots and agents. In addition, the experimental results confirm that neural networks are a vital area of research in robot learning.

### **3.3 Cognitive Robotics and Neurorobots: A Synthetic Approach to Understand Cognition**

This subsection reviews research from different areas that contribute to the use of cognitive neurorobotics and describe in detail some seminal models. The purpose is to explore the research trend of this field, and to provide some useful mechanisms for the future work. It consists of cognitive development, learning, imitating, and language grounding in robots.

#### **3.3.1 Cognitive Development**

Lungarella et al. (2003) survey the relevant research in the field of developmental robotics. They point to the importance of having a body by means of embodiment. Robots do not need to have precise models of the world; indeed they assert that more importance should be given to the result of the interaction between simple robotic systems and environment (Brooks, 1991). The authors suggest many schemes that are integral in the construction of developmental robots. For example, development is an incremental process, development as a set of constraints, development as a self-organising process, and social interaction. This review also provides a list of research directions in the field, including autonomous learning and the research trend that realises characteristics of human-like features as crucial aspects to acquire human

intelligence.

Weng (2004) interpreted a developmental robot as the robot that generates its brain through interaction with the surrounding environment and humans online in real-time. He introduces the concept of Self-Aware Self-Effecting (SASE) agent, and the paradigm of an autonomous mental development (AMD). SASE defines internal representation of the world as the brain of the model which can be adapted by the interaction with internal sensors and internal effectors. The author argues that the SASE agent differs from traditional models in that it can update the internal representation of the world to acquire a developmental ability. An autonomous development system consists of two parts, the first is the prerequisite or task-specific programs and the second is task-nonspecific or developmental programs. In this scheme, during operation, the autonomous system interacts with human users to update its performance through training and testing phases via the developmental programs. The author tested the proposed schemes with two robots (SAIL and Dev) and claimed that the robots can automatically update and generate their own internal representation. He also postulated that the scheme of autonomous development system and SASE can be considered as a starting point of the new direction of developmental robots.

Acquiring a new skill, even in human beings, often begins with a limited capability. The new skill can be mastered when the humans' body and their brain are developed. During developmental stages, human children learn many skills both physically and cognitively through playing and social interaction. In a credible game, hide and seek, children at the age of 3-4 years old are able to start playing but in a very limited ability, particularly when hiding. That is because of the children's lack of perspective taking ability. They play the game by using only the knowledge of objects and places they have had. For example, which object that they can get in, which objects that can stay under.

Trafton et al. (2006a) realised this characteristic and demonstrated that a cognitive ability to play the game of hide and seek can be created and deployed in a robotic platform. They hypothesised that a computational model that replicates what humans used in their cognitive processes (e.g., representations, algorithms) should work well with humans rather than a computational model that does not. They also stated that thinking or reasoning in humans are not formed in mathematic formats, rather people developed the understanding of surroundings by a combination of spatial, temporal, and propositional knowledge. The perceptual abilities in children age 3-4 are extremely limited and they will be learned later (e.g., aged 5.5). Therefore, this work uses the example of “how do children learn to play hide and seek?” from two children of two different ages, namely 3.5 and 5.5. The 3.5 year-old child is in a situation that she learns to play the game while another child already knows how to play the game. They found that the two children use different hiding methods. For example, the child aged 3.5 just closes her eyes in order to hide as an initial concept of hiding. The child aged 5.5 seems to have a well develop perceptual ability. However by giving the child some suggestions such as “You might not want to hide in the open”, the child aged 3.5 can learn not hide in open areas. A computational model of this work was programmed on ACT-R cognitive architecture and deployed on the hardware of a real robot. The cognitive architecture such as ACT-R leverages the mechanisms underlying humans' cognitive processing. Through the implementation of a control system on the ACT-R benefits the researcher in which the model can be tested and monitored to eliminate unexpected behaviours that might be harmful to people. After the modelling step, the computational model can be deployed in both robotic platforms of simulation and physical robots. The robot used in this work is an indoor type wheel robot (nomad200), it has a digital camera with CMVision (<http://www.cs.cmu.edu/~jbruce/cmvision>) and 16 distance

sensors to recognise objects and places, and using the dead reckoning method to compute its current position. The robot consists of pre-programmed non-cognitive capabilities such as map generation, localisation, and path planning to assist movements in an indoor environment. The authors focused on using a real robot because they believed that a real interaction between robots and humans can not be captured using computer simulations. In this work, by using a speech recognition engine (ViaVoice) the interaction between humans and robot can be done via spoken language. The spoken language, as a regular expression, will be parsed by a parser and reformed to a format that is suitable for the model. In essence, speech is phrased into appropriate commands. The model includes several types of learning such as new knowledge acquisition, links between knowledge, production rules, and a compact form of explanation based learning. The model simulated the situation that when the robot gets stuck in local minima, like a child aged 3.5, it provided some suggestions that can help the situation. It is important to note that this work replicated only hiding behaviour. The authors claim that a strategy to perform finding can be derived from the hiding strategy.

### **3.3.2 Learning**

It is widely accepted that complex behaviours corresponding to a changing situation found in animals cannot be pre-programmed for robotic systems. Indeed, such behaviours should be collected and created through adaptive or developmental processes during interaction with the world (Weng, 2004; Pfeifer & Gomez, 2005; Pfeifer & Bongard, 2006). During the developmental period, human children and non-human primates acquire a plethora of new skills and knowledge through social interaction, including naming objects, playing games, observation actions, and joining cooperative tasks. To create adaptive robotic systems that can grow and scale up its

ability akin to the human children, robot scientists need to consider the adaptive processes underlying children's thought. In addition, the need of physical body and vision systems of the robot will be raised as most of the processes of acquiring new skills in the human children has been achieved through observations and representations e.g., others' actions, object movements. Though there are a number of presented simulators that offer an ability to conduct experiments with robot learning, the interaction between humans and robots such as cooperative tasks and shared intentions cannot be thoroughly tested in simulators. Dominey and Warneken (2011) demonstrate cooperation between a human and a robot in a shared workspace. The robot system consists of a 6-DoF arm and a gripper which can manipulate objects in catch and moving positions. A camera fixed to a wall is used to observe the result of actions performed by the human and the robot arm. Spoken language is used to communicate between a human co-operator and the robot. By using the CSLU Rapid Application Development toolkit (<http://cslu.cse.ogi.edu/toolkit>) as a language processor, one sentence will be extracted into a command format which is directly used as a specific step of a task and stored in the robot's internal representation forms. It is applied to trigger the system based on the current situation of the robot or the human. The authors discuss the importance of actions sequence representation in store and recall to incorporate during the task. The robot's internal representation or "world model" can be changed through specific commands underpinned by vision and proprioception. The main focus of this work is also the internal representation which consists of three sets of action sequences called "Me Intention", "You Intention", and "We intention" which underpins cooperative tasks. The task is a turn taking scenario in which the human co-operator will say a sentence such as "I do this" follow by showing the robot an action of moving an object from one place to another. To this end, the action is reversed when

telling the robot to move the object from its current place back to the beginning position by saying “You do this”. “Me intention” stores only the robot actions, “You Intention” stores the human coordinator actions and the “We intention” stores both actions in sequence. By using this technique the turn taking game of moving objects between a human and a robot can be constructed. Dominey and Warneken (2011) claimed that by observing the human coordinator demonstrating how to play the game 4-5 times, the robot can participate in the game in the same way as human children do. The vision system in this work is not a part of the robot as it acts like a third person observer. This work demonstrates an assistance action by the robot when the human acts like he is stuck in the game. By swapping the “Me Intention” and “You Intention” the robot can invite the human to play the game and it can swap to reverse the respective roles.

The “A-not-B error” reflects the basic processing mechanisms in the early development period of human children. Decision making of the children at the sensorimotor stage (age 0-24 months) can be easily explained by the basic Hebbian processes (Munakata & Pfaffly, 2004), which involves repeatedly showing a child two objects which are called “A” and “B” in turn at specific locations. Indeed, object “A” is located on the left while “B” is located on the right. Children appear to bind a strong association between an object's name and its location rather than the visual identifying features. The process and resultant outcome remains the same even when swapping the location of the two objects; i.e., “A” was placed on the right and “B” was in the left. In this respect, interaction profiles between children’s bodily states and features of perceived objects must be unique in order to benefit the child in recognising sensorimotor experiences. Morse et al. (2010) replicated an experiment in human children into a humanoid platform (the iCub robot). They demonstrated the use of robotic platforms as cognitive tools. The authors explain what mechanisms underpin

children's behaviours. In the "Modi experiment", the children ability of mapping a linguistic label to objects and its spatial location were tested. This experiment was originally conducted by Smith and Samuelson (2010) who conducted four main experiments with a human child. In the first experiment, an experimenter shows the child two different objects by putting them on a table in sequence some 3-4 times. The two objects are typically toys which are different in shape and colour. Each of them was presented at a specific location, left or right, in front of the child. The child was asked to pay attention to a specific location (by the experimenter's hand waving) with the pronunciation of the word "Modi". At the end of this experiment, the child was shown both objects at the same time and asked which one is the "Modi". In the second more complex experiment, the presentation of objects was swapped. An object that was first shown on the left was shown on the right at the second experiment followed by the word on an empty space with the word "Modi" as in the first experiment. This setting raised a difficulty in comparison to the second experiment because of a location conflict of the object that the child has learnt. Unsurprisingly, the correct answer is dropped compared to the first experiment. The third and fourth experiments were mostly the same as the first and second experiment respectively, except that the word "Modi" is pronounced when an object still appeared in front of the child. The result showed that the latter experiments cause a stronger conflict to the child's internal representation of the link between the object and the word "Modi". In Morse et al. (2010) these four experiments were simulated on the iCub. Neural networks were used to manipulate sensorimotor and additional inputs from an instructor. The majority of the network is underpinned by self-organizing maps (SOM) which is called "hub". By means of competitive learning of SOM which provides a clustering ability, sensory inputs from different modalities can accompany cognitive skills such as object categorisation. The

robot recognised objects by using different colour and shape profiles. There are three types of inputs associated in this work, namely spatial location of present objects (left, right), objects' visual features (colour, shape), and a linguistic label from a tutor (speech). The output of the model is a control of a hand pointing to a location of object that the robot believed to be a “Modi”. The idea underlying this work is that, looking at a specific location (left or right) influences the particular joints' angle underlying the gaze control of the robot (the robot was set to look for a salient object in its stationary space). To different locations, the joints' values will be different. When the robot looks at the left object, the model mapped current states of motors to the objects visual features. Through repetition of this process several times over, the Hebbian learning of the model creates an association between these two input modalities. In addition, the coming of linguistic labels will be the third input that the model has to associate with its previous knowledge. This is demonstrated by the experimental results both in children and in the robot. Saying the word “Modi” while an object is in sight creates a strong association between the object’s features and bodily configurations.

### **3.3.3 Imitation**

In order to collaborate with humans, robots need imitation skills. Imitation skills are believed to be a mechanism underlying developmental processes. Schall (1999) focuses on imitation learning as a promising route to autonomous humanoid robots. This hypothesis is inspired by the fact that it is impossible to undertake manual coding to control a large number of DoF in the humanoid robots. Therefore, a learning approach should be one alternative way to overcome this issue. The author points out that an important mechanism underlying learning is a functional connection between perception and actions. Based on the concept of mirror neurons, this connection could be

determined as neural mechanism of imitation. Samples of imitation learning system from different viewpoints have been reviewed and described. For instance, behavioural sciences reported that human infants have an ability to replicate perceived facial gesture since birth (innate). The definition of true imitation is also provided, which should comprise of three features i.e., a demonstrated movement is new for the imitator, the imitator replicates the same movement and achieves the same goal. Secondly, a predictive forward model with supervised neural networks was proposed as a learning mechanism of sensorimotor transformation. The visual perception of the demonstrator's movements is converted to represent in neural spaces that can be mapped to the internal representation of an agent's own movement. From cognitive neuroscience, based on the study of a monkey brain, the pathway of imitation learning roughly interprets as lying in three areas: Superior Temporal Sulcus (STs), 7b, and F5. STs is suitable to extract the attention and goals of others. F5 (the mirror neurons area) is responsible for the execution of goal related movements. Lastly, an imitation learning system from the viewpoint of robotics, leverages pathways of information processing and comprises of three main parts: motor command generation, movement primitives, and learning systems. Visual input contains information of objects and the posture of a demonstrator. Consequently, the demonstration movement will be extracted into a sequence of state-action-state transitions. The state-action-state will be converted into symbolic if-then rules which are suitable to program a robot. The author suggests the three important keys needed for imitation learning in robots are: a theory of motor learning, a compact state-action representation, and the interaction of perception and action. Imitation learning offers a benefit to robotic applications in which it helps reducing the size of possible actions or a search space.

Infants use the imitation learning ability to understand other people's thought of

actions (e.g., goals, intention) and learns from them through social interaction. Demiris and Meltzoff (2008) analyse imitation skills in infants in order to design a mechanism that will be used in robots. They focus on two key features which play an important role in infant learning: initial conditions, and developmental mechanisms. Initial conditions are believed to be equipped within the infants since birth, and during life they acquire and master new skills through developmental processes. In a robot, the authors designed the two key ideas that underlie imitation mechanisms as in the infants. First, to capture the way infants realise demonstrator's actions for robots' perceptual system, and second, to design the internal models which are capable of acquiring new skills during development. They suggested certain scenarios that might be useful in designing robots that are capable of learning from observation. In the beginning, the initial conditions for the robot can be achieved by pre-programming in the same way as infants born with innate skills. Initial conditions must be able to assist the robots in comparing their current state with a goal state of the demonstrators. This ability underpins imitation in which it drives robots' actions toward a specific goal action. The comparison has to be done by using representations of visual and proprioception during imitation. Robots have to have a good visual perception system that can recognise people actions as in visual neural system of infants. The information about the demonstration must remain in a memory system of the robots. In infants, during the developmental period, imitation skills can be improved. For example older infants can understand the demonstrator intentions to do actions not just replicate the observed action. Some researchers (Meltzoff, 2007) stated that infants can improve their imitation skills by the use of a self-learning development phase, in which bodily states are associated with mental states. Robots can achieve this ability by replicate the self-learning system. Lastly, the authors suggest that the combination of inverse and forward models in assisting an

ability of understanding others as the concept of internal predictor. A forwards model provides a prediction of the next state which will assist a motor command selection. After compensation with a goal state, the signal from the forward model will be fed back to an inverse model to adjust the parameter of the selected actions. These processes appear to replicate the concept of mirror neuron systems. It underlies action executions and at the same time carries out perceived actions from the demonstrator. This work provides ideal mechanisms and useful evidence for constructing imitating robots.

The finding of mirror neurons (Gallese et al., 1996) has inspired the concept of empathy (or understanding other's intention), and imitation. Through social action mirroring in primates, Saegusa et al. (2011) shows the experiment of imitation that demonstrates how robots replicate human actions based on the observation of object movements caused by itself and by a human. The experiment set-up starts by first, letting the robot do some motor babbling actions to explore its own bodily control scheme (hand and arm) using visuo-motor perception and auto generate actions. This process creates an association between motor outputs and the resulting hand positions. Following this the robot was set to observe the effects of objects when performing a particular action on it. Finally, the robot identifies humans' actions as its own actions. The sensory input of this work is predominately obtained by visual and proprioceptive sensing known as "active perception". There are three types of actions performed by the robot on an object: hold, place, and take regarding object manipulation. The authors have shown that after observing a human performance on object manipulation, the robot can replicate the same action. This work offers an alternative method of intelligent control by means of imitation rather than hand-coding.

### 3.3.4 Language Grounding

Language plays an important role in cognition and learning. In the dual hierarchy of language and cognition vision (Perlovsky, 2011), language is suggested to be acquired during development, experience with linguistic symbols and sounds are grounded in the embedded model of language and cognition. Moreover, observing object movements makes an agent realise the meaning of action words (Marocco et al., 2010). For example, motion verbs such as rolling and sliding can be mapped to a specific dynamical result from different objects.

In autonomous cognitive systems such as robots or agents, language grounding and grounding transfer are important aspects allowing the system to acquire new skills or meaning of linguistic symbols. When interacting with changing environments, this ability will provide online acquisition for further suitable actions. Cangelosi and Riga (2006) presented a study of sensorimotor grounding and grounding transfer in epigenetic robotics. Linguistic ability can be formed through imitating basic actions from one cognitive agent to another. A computational model of this work is based on a feed-forward neural network with error back-propagation training technique. Two simulated robots are used as cognitive agents to demonstrate the imitation through communication, actions, and language. One robot was set as a demonstrator; it autonomously performs predefined basic actions. Another one is known as learner, which is controlled by a neural network. The network controller of this robot consists of three training stages: basic grounding (BG), higher order grounding 1 (HG1), and higher order grounding 2 (HG2). In the training of basic grounding, all joint values of the demonstrator will be passed to output units of the neural network as a preferred action. Input units are mapped to specific action names using a verbal instruction parser. There are 8 action names used in this stage: CLOSE\_LEFT\_ARM,

CLOSE\_RIGHT\_ARM, OPEN\_LEFT\_ARM, OPEN\_RIGHT\_ARM, LIFT\_LEFT\_ARM, LIFT\_RIGHT\_ARM, MOVE\_FORWARD, and MOVE\_BACKWARD. This training will be repeated for 50 epochs. Following this, the network allows the learner robot to imitate the demonstrator actions corresponding to the name of actions. Therefore, when an action name is fed as inputs to the network, it can produce a desired motor configuration to control the learner robot. This training stage demonstrated the understanding of grounding of basic actions in the learner robot. The next step of training is higher order grounding. This stage shows the transfer of basic actions to higher ones. The higher order action of this stage consists of 5 action names: GRAB, PUSH\_LEFT, PUSH\_RIGHT, OPEN\_ARMS, and ARMS\_UP. The combination of two basic actions creates a new higher order action; for example, the action GRAB is a combination of the basic action CLOSE\_LEFT\_ARM and CLOSE\_RIGHT\_ARM. Therefore, each higher order action will be trained by following two steps. In the first step, it begins with feeding one basic action name (e.g., CLOSE\_LEFT\_ARM) to the network and captures the output values. Note that there is no training in this step. After that feed, a higher order action (e.g., GRAB) to the input units of the network and set the output units with the capture value of the previous step. The succeeding step will be the same but using a different basic action for GRAB; in this case will be repeated with feeding of CLOSE\_RIGHT\_ARM. In the higher order grounding 2 training, it is the same process as in the training of HG1 except that it is a combination of basic action and higher order action 1, and will be done after finishing the network can learn the higher order action 1. This work provides a useful mechanism underlying the ability of linguistic grounding transfer in robots. To this end, new actions can be formed when the robot has some definitions of basic actions and symbols connected to it.

To sum up, cognitive science involves the study of the human mind, psychology considers human behaviour/cognitive development, and neuroscience also studies the human brain. Human cognition appears to be the best example for the study of high level cognition. In its extreme, D'Mello & Franklin (2011) suggest that cognitive models should be designed after humans. Cognitive science provides the basic understanding of the human mind and human thinking. Cognitive scientists model cognitive architecture following the components that are believed to underlie human cognition. Psychologists create theories of the mind that predict human behaviours, conduct the experiment and revise their cognitive models. This principal provides a clear directional approach to an improved model. Psychologists and cognitive scientists often work together to fulfil each other's knowledge. However, it is not necessary that every intelligent system has to follow this scheme. Some systems rely mainly on traditional artificial intelligence approaches and focus on high level cognition such as decision making and ignore any biologically aspects, but they can show an excellent performance, such as a chess program that can beat the cognitive ability of a human world champion.

# Chapter 4

## Tools for Modelling Mental Imagery

This chapter describes tools and mechanisms which were applied to model mental imagery in humanoid robots. Including, the description of TRoPICALS - a computational model account for sensorimotor compatibility effect, population coding neural networks, learning algorithms and the humanoid robot iCub.

### 4.1 TRoPICALS

TRoPICALS (Caligiore et al., 2010) is a computational model of object affordance designed to account for action-language and stimulus-response compatibility effects, studied experimentally in cognitive psychology (Tucker & Ellis, 2001; 2004). It achieves this based on an architecture that considers the prefrontal cortex as a key source of the top-down control of the areas that participate in the selection of affordances and execution of actions.

The account of compatibility effects given by TRoPICALS is based on four general brain organisation principles incorporated in its architecture: (a) the two-route organisation of the sensorimotor brain into the ventral and a dorsal neural pathways; (b) the guidance of action selection based on prefrontal cortex “instructions”; (c) the selection of actions within premotor cortex based on the competition between different affordances with bias from prefrontal cortex; (d) the capability of language to trigger internal simulations of the referents of words (Barsalou et al., 2008). The acronym

“TRoPICALS” summarises these principles: Two Route, Prefrontal Instruction, Competition of Affordances, Language Simulation. The model reproduces compatibility effects as an agreement or disagreement (compatibility or incompatibility) of top-down PFC bias with the available affordances of objects which produces slow or fast reaction times. TRoPICALS provides a broad framework to account for several types of affordance related compatibility effects involving grasping, reaching and language, and is capable of generating novel testable predictions, including some predictions on the possible outcomes of compatibility experiments with Parkinson patients (see Caligiore et al., 2013; the latter predictions are relevant as Parkinson patients have damaged excitatory and inhibitory neural circuits linking prefrontal cortex to premotor cortex via supplementary motor cortex).

The TRoPICALS consists of many parts as shown in figure 4.1. It leverages the cortical components of the two pathways of information processing: dorsal and ventral. In this scheme, the brain takes information through the visual cortex and primary auditory cortex and passes the “where” information through the dorsal pathway, while the ventral is responsible for the “what” information. The ventral pathway consists of Prefrontal Cortex (PFC), Superior Temporal Cortex (STC) and Ventral Occipito-Temporal Cortex (VOT). The dorsal pathway consists of Premotor cortex (PMC), Parietal Cortex (PC), Visual Cortex (VC) and Somatosensory Cortex (SSC). However, the two pathways are partially linked.

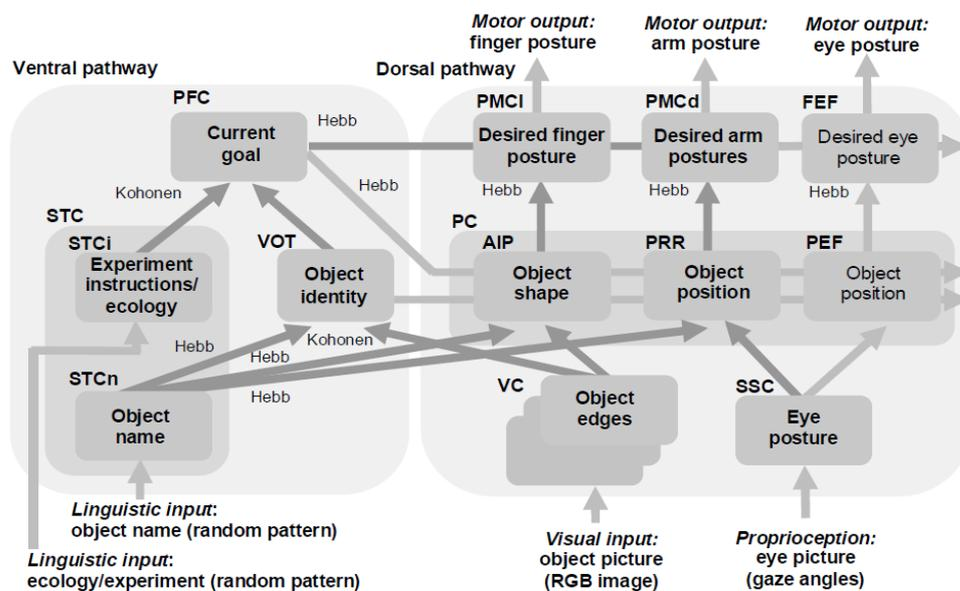

**Figure 4.1** The TRoPICALS's model architecture (from Caligiore et al., 2010)

In this model, as a replication of the brain's functions, the PFC is responsible for high level cognitive ability such as decision making. The PMC is responsible for generating motor outputs. The VC extracts abstract information from perceived images, in addition it has the function of edge detection and feature extraction. The PC consists of three components that are responsible for objects' affordances representation, for example representation of object shape, object position. Connections between components in the model are indicated with arrows. The connections are typically weight vectors that underpin information transformation between specific pairs of maps. It appears to have three types of connection namely, hand coded connection, Hebbian, and Kohonen. The hand coded connections are predefined weight values, while Hebb, and Kohonen refer to the weights that need training by Hebbian learning and Kohonen competitive learning respectively. Information processing in the TRoPICALS is considered as cross-modal association. The information from different modalities e.g., visual and auditory, involves many components in both pathways.

## 4.2 Population Coding

According to TRoPICALS, information is stored and represented in neural maps based on the concepts of population codes. Population coding is an interpretation of neural processes across clusters of neurons in particular areas. Information appears to be encoded by population of neurons rather than single cells. It is believed that visual cortex encodes many features of perceived stimuli e.g., orientation, colours, directions through clusters of cells. For example the "place cells" in a rat's hippocampus that identify a location of the rats in a maze environment. Firing characteristics of neurons, even in an individual neuron, are complex however it may serve as an insight on how to understand information processing in the brain. Observation of single cells in the visual area of the monkey's brain (Hubel & Wiesel, 1968) showed selective firing according to a specific stimulus e.g., orientation. Moreover, when monkeys grasp for an object in front of them, researchers (Georgopoulos et al., 1982) found that single cells will be sensitive to a particular direction that their hand were approaching. This firing characteristic can be interpreted as neural codes mapping to a particular direction or orientation as well. However, firing rates or number of spikes is not persistence. Repeated showing the same stimuli to the monkeys results in different firing patterns or a different number of spikes. To overcome this issue, neuroscientists (Pouget, Dayan & Zemel, 2000) proposed the use of Gaussian tuning curves to simplify the characteristic of neural firing (in both rate codes and temporal codes). The tuning properties of individual cells when interpreted as a map of neurons (neural space) can represent some information e.g., preferred direction.

A standard model was also studied by Pouget, Dayan & Zemel (2000) as a captured pattern of neural firing in the monkey's visual field. There are two characteristics of neural activation concerned in the standard model: an average response over population

of neurons, and a noise term. Therefore the simulated firing rate can be described by the following equation:

$$r_i = f_i(s) + n_i \quad (4.1)$$

Where  $r_i$  is a number of spike of neuron  $i$  according to stimulus  $s$ .  $f_i(s)$  denotes average response and  $n_i$  is a noise term. The average response over the noise signal made the standard model more likely to the activity of neural population. With Gaussian tuning curves, information will be distributed over a number of neurons. Each neuron responds to the same information (input feature) with different level of activation.

Unlike the model of artificial neurons in layered neural networks, population coding neural networks do not aim to overcome decision making or pattern classification. On the other hand, it is suitable to encode and represent information that researchers have to find optimal methods to decode the stored information in this kind of networks.

## 4.3 Learning Algorithms

### 4.3.1 Hebbian: Supervised Learning

The Hebbian learning rule was derived from the famous quote “the cells that fire together wire together” postulated by Donald Hebb in 1949. The key idea is focusing on the existence of connections, synapses, between two neurons i.e., pre- and post-synaptic neurons. If the two neurons are connected, in order to make the post-synaptic neuron fire, an activation of the pre-synaptic neuron and a current action potential of the synapse have to meet a proper constraint, by means of multiplication. If the result is high enough to reach a setting threshold then the post-synaptic neuron will be fired.

In computation, the term synapse refers to a connection weight between two neurons which are normally represented by the constant value  $w_{ij}$ . The two equations

below illustrate how the connection weight is changed and updated. Note that, the equation 4.2 is called Oja rule (Oja, 1982), a Hebbian like equation that solves the problem of the basic Hebb rule causing a weight growing without bound.

$$\Delta w_{ij} = \eta a_i (a_j - w_{ij}) \quad (4.2)$$

$$w(t)_{ij} = w(t-1)_{ij} + \Delta w_{ij} \quad (4.3)$$

where  $\Delta w_{ij}$  denotes the weight change from neuron  $i$  to neuron  $j$ ,  $a_i$  and  $a_j$  denote activation potential of neuron  $i$  and  $j$  respectively,  $\eta$  denotes the learning rate, and  $w(t)_{ij}$  is a weight value at a particular time step.

In this thesis, several cortical areas of the brain are modeled as 2D neural maps. Hebbian learning was applied to learn the relation between specific neural maps e.g., information in the V1 that influences the neurons' activity of the parietal cortex. Figure 4.2 illustrate an example of the connection between two neural maps i.e., input and output.

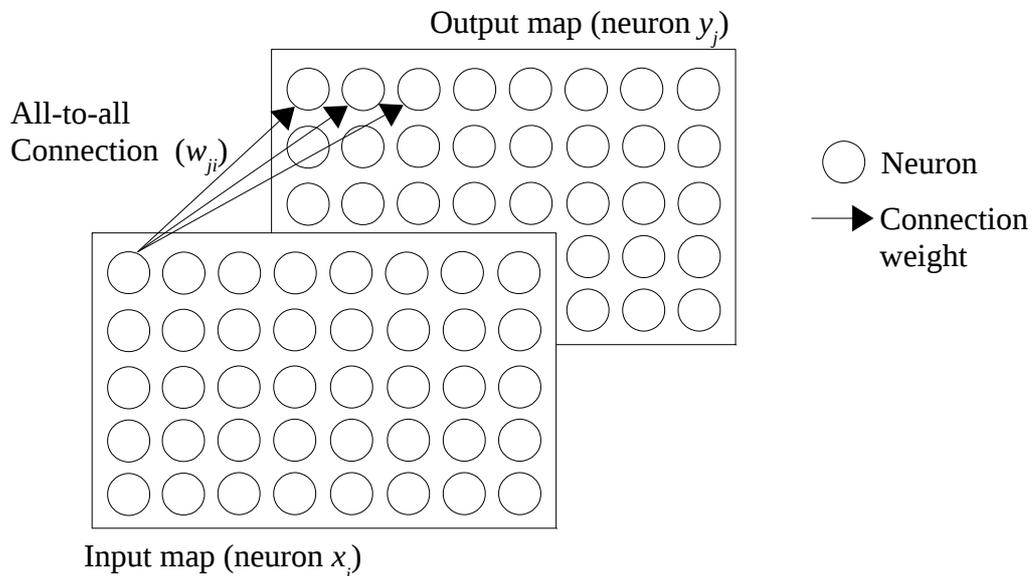

**Figure 4.2** An example of a 2D Hebbian network with all neurons from the input layer connect to all neurons of the output (all-to-all connection).

In order to avoid drawing too many arrows as connection weight between the maps, the three arrows are used to illustrate sample connections from one neuron of the input

map to other three neurons of the output.

This kind of network requires pairs of input output to be its training patterns in order to learn the relation between them. After successfully trained, the feed forward process that propagates input information through the connection weights can generate desired output as a prediction. The feed forward process can be calculated using the equation below:

$$y_j = F\left(\sum_i x_i * w_{ji}\right) \quad (4.4)$$

where  $y_j$  is a final activation of the output neuron  $j$ .  $F$  is a transfer function (e.g., sigmoid or hyperbolic tangent) that transforms the summation of all input neurons' activity  $x_i$  with their connection weights  $w_{ji}$  to the output neuron  $y_j$ .

### 4.3.2 Kohonen: Competitive Learning

A Kohonen Self Organizing Map (SOM) (Kohonen, 1990) is a well-known neural network learning technique. It is an unsupervised learning technique that is able to adjust the weight values without any desired output. This means only a set of inputs is needed in order that the SOM will generate an output map.

At the heart of SOM, there are two important steps needed. First is the calculation of the best matching units (BMU), typically using Euclidean distance technique. The BMUs will be the central unit of each cluster in the map (output). Typically, in a two dimension SOM map, each neuron will be located in a specific position (e.g., x,y coordination) with a random activity level. The latter step is a weight updating. For each training cycle, the input to the SOM network will be changed and these two techniques will form salient clusters in the map. It is important to note that, the output map is unpredictable. Therefore an output map needs a manual interpretation. The SOM

learning rule can be implemented using the following equation:

$$w(t)_i = w(t-1)_i + \Theta(t-1)_i \eta(t-1)_i (v(t-1)_i - w(t-1)_i) \quad (4.5)$$

where  $w(t)_i$  denotes current weight value of neuron  $i$  at time  $t$ ,  $w(t-1)_i$  denotes an old weight value of the neuron  $i$ ,  $\Theta$  denotes the amount of influence on the distance between neuron  $i$  and the best matching neuron in a map,  $\eta$  denotes the learning rate,  $v$  denotes input value to the neuron  $i$ . Note that,  $\Theta$  and  $\eta$  decrease over time.

A major processing characteristic of SOM is clustering. It transforms high dimensional inputs to represent in a low dimension known as data visualisation; normally in 2 or 3 dimensions. Each input will be represented in a unique area in the SOM map. We can apply this characteristic to create a neural map that represents identities among a number of input maps. A unique cluster and its input can be used for the mapping of a new training set for another learning process. In much work, a functional purpose of a SOM map is to provide an ability of complex mapping between input modalities.

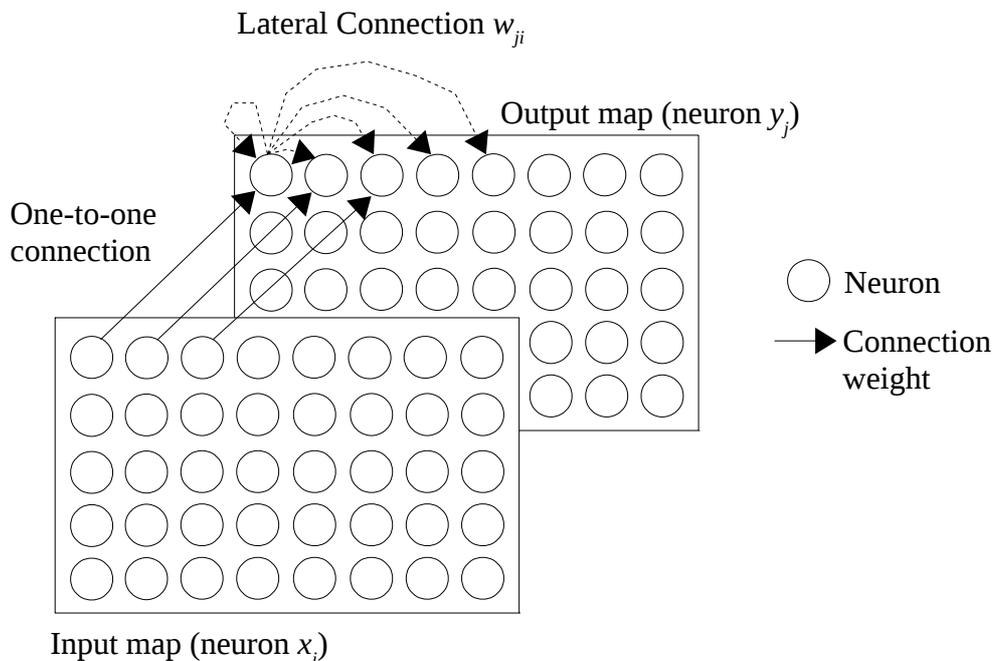

**Figure 4.3** An example topology of the Kohonen network.

Connection weights of the SOM network refer to the lateral connection (dashed arrows in Figure 4.3) within the output map. They play a central role in this kind of network and training processes are involved mainly in this layer. The connection between the input and output maps (one-to-one connection) is only used to propagate the input signals in the training processes of the SOM. In Figure 4.3, the dashed arrows are used to show one sample that one neuron of the output map is connected to other neurons within the map including itself. The readout process for using the SOM

In addition, the algorithm for training Kohonen network can be listed as below:

1. Initialize the lateral connection weights with small random values.
2. Randomly select training input.
3. Calculate the best matching unit (BMU).
4. Update the connection weight (using Eq. 4.5).
5. Repeat step 2 for N iterations e.g., 10,000.

After training, the feed forward processes follow the similar processes as stated in Eq. 4.4. However, the actual activation of each output neuron ( $y_i$ ) has to be normalized using the below equation:

$$y_j = y_j / \max(y) \quad (4.6)$$

where  $\max$  is a function returning the value of the output neuron that has maximum activation.

#### **4.4 The humanoid robot iCub**

Throughout this thesis, the humanoid robot iCub, physical and simulator, were used as simulated participants to reproduce empirical psychology data as a synthesis tool. The iCub (Metta et al., 2008; <http://www.robotcup.org>), (Figure 4.4a), is a humanoid robot

platform that is an ongoing project led by the Italian Institute of Technology (IIT), Italy. The humanoid robot, iCub, is designed to behave akin to a 3-4 year old human child. It is an open system under GNU GPL/FDL licenses, allowing other researchers to freely customise their own iCub or even create a new one. Approximately 20 iCubs have been distributed to many robotic laboratories worldwide (mostly in Europe). Figure 4.4b illustrates the iCub simulator developed by Tikhanoff et al (2008).

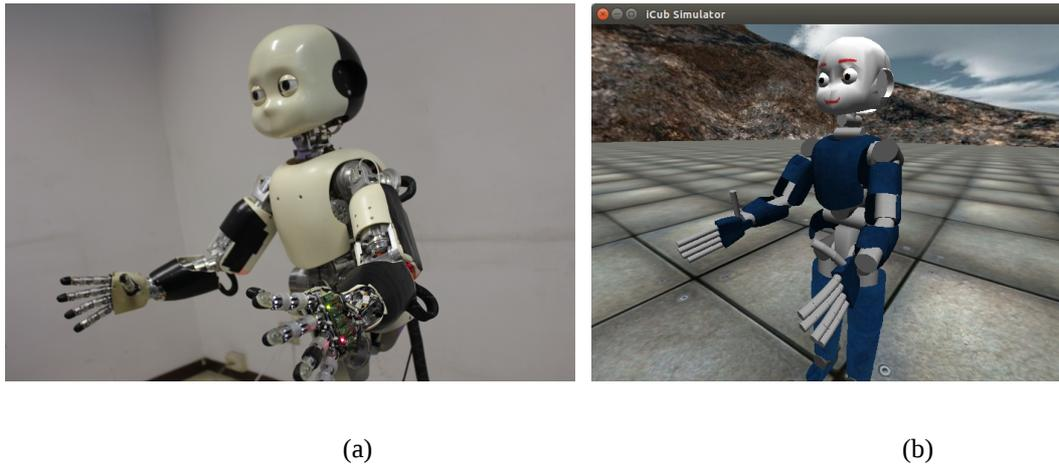

**Figure 4.4** The iCub humanoid robot: (a) Real robot, (b) Simulated robot.

The iCub is approximately 1 metre tall, weighs about 22 kilograms and consists of human like body structures i.e., two eyes, one head, two arms, two legs, and a torso. The configuration of joints and sensors are carefully examined and placed in acceptable positions akin to the layout of a human. The robot has been designed to participate in the domain of cognitive robotics. Its main benefit is offering an opportunity to prove cognitive models with a physical robot in the real world, and provides a clear reproducible experiment. It consists of a number of motors and sensors which are connected to a central computer (PC104), located in the robots head. The PC104 acts as a central hub to distribute commands and collect data to and from particular devices. There are a set of ready to use pre-defined actions to generate desired actions in the iCub. In order to interface with the iCub, communication with YARP processes is required. YARP runs on top of the iCub's network and manages the communication

between user programs and the PC104. In this way, many researchers can share the iCub's facilities.

At the IIT, the iCub's inventor team continues integrating and improving more reliable human like sensors into the new iCub such as tactile sensors and finger tips. However, the fact that the iCub cannot walk has lead to two major works on redesigning its motor system, for legs and ankles (Tsagarakis et al., 2011). This redesign is working towards the creation of a platform to enable the iCub to move around (iKart, <http://www.icub.org>).

This section draws on the iCub robot research as it is the most advance humanoid platform to date. There is a plethora of research in the field of cognitive robotics that involves the use of the iCub platform in both simulation and the physical as their cognitive tools. In this context, the iCub can be considered as an important aspect to further understanding the theories of cognition. Research with the iCub spans from learning sensorimotor transformation such as reaching, grasping, crawling, drawing, archery skills to high level cognitive abilities such as imitation and language.

The difference between simulated and physical version of the iCub can be listed in terms of advantage and disadvantages. The iCub simulator provides accessible and convenience of use to users. There is no need of maintenance, space, power supply, and there is no risk of breaking the robot's parts. In addition, interfacing, commands, and networks required for using the simulator are also identical to the real one. Importantly, the simulator is free of charge. The disadvantage can be the limits of handling a variety and accurately of physical interactions.

On the other hand, the real iCub obviously offers real world conditions e.g., physical interactions with objects and humans. Researchers that tend to implement real world robotic application have to target on this version of the iCub. To some community

(e.g., roboticists), conducting experiments with real robots can be seen as tackling more challenge than doing that in the simulator. Because this has to deal with effects from the law of physics e.g., gravity, force, torques, inertia, friction, etc. The disadvantage can be the case of difficulty and complexity of use/settings, and can be unaffordable for some researchers due to its cost.

# EXPERIMENTAL STUDIES

## Overview

This Ph.D. thesis aims at permitting the use of mental imagery in humanoid robots. This additional section tends to provide a logical connection linking all empirical experiments conducted throughout the thesis. The use of **mental imagery in humanoid robots** has been demonstrated through a number of neurorobotic models engaged in solving the two spatial problem-solving tasks i.e., mental rotation and tool use. By means of information/cognitive processing, mental rotation obviously involves the use of mental imagery, while in the tool use, we suggested that mental imagery can be used as an imagined outcome of action required in the process of self-determined reward. In particular, the proposed neurorobotic models were designed and constructed based on brain-like processing mechanisms and followed the concept of embodiment.

In sum, the studies in **chapter 5** are an initial work that explore the possibility of exploiting mental imagery in humanoid robots through a typical mental rotation task. **Chapter 6** extends the capability of the initial work by focusing on two main aspects i.e., generalisation and a more precise bio-constraint mechanisms that might get involved in the solving of mental rotation in the brain. Finally, **chapter 7** confirms an assumption that all relevant cognitive functions used in the previous experiments i.e., motor skills, affordances, and mental imagery can be acquired through the process of sensorimotor learning. In addition, chapter 7 extends the extent of using mental imagery in humanoid robots from the case of mental rotation to tool use. In which, tool use understanding and mental imagery can be seen as emerged through the processes of

sensorimotor learning. There is evidence suggests that infants exhibit tool use behaviors at an early age, and this capability is gradually developed from subjective to objective stage of development. (Schlesinger & Langer, 1999). In addition, according to Piaget's theory of child development, the age of 18 months is the beginning of the sensorimotor stage 6 that infants begin to have an ability of using mental imagery (Piaget, 1952). Thus, the demonstration of how to use a tool (e.g., Rat-Fischer et al., 2012) might provide missing information about actions and outcomes of how to solve the task to the infants. In which, the infants might fulfill their understanding of how to solve a given tool use task through the use of mental imagery.

# Chapter 5

## Modelling Mental Rotation

This chapter presents the two initial experiments on a neurobotic model of mental rotation whose macro architecture was broadly linked to brain areas. This model was able to solve a simple mental rotation task of 2D visually-perceived objects in a simulated humanoid robot, the iCub (Tikhanoff et al., 2008). In addition, the model was developed within an “embodied cognition” theoretical framework for which high-level cognition processes rely on the same areas of the brain used to process analogous sensorimotor information (Borghi & Cimatti, 2010). According to this view, off-line cognition, such as mental rotation and imaging, is body based: “even when decoupled from the environment, the activity of the mind is grounded in mechanisms that evolved for interaction with the environment—that is, mechanisms of sensory processing and motor control” (Wilson, 2002). The models departed from another model – TRoPICALS – developed within the “computational embodied neuroscience” framework aiming to establish detailed links between embodied cognition and behaviour and the brain system-level mechanisms underlying them (Caligiore et al., 2010; Caligiore et al., 2013; TRoPICALS focused on compatibility effects, Tucker & Ellis, 2001, and affordance processing, Gibson, 1986; Rizzolatti & Craighero, 2004).

## 5.1 Experiment 1: A Cognitive Robotic Model of Mental Rotation

In this experiment we propose a computational model, investigating a neural operational hypothesis on how the information processing taking place in parietal and premotor areas might be involved in mental rotation. This operational hypothesis is based on the integration of affordances and forward model accounts for mental rotation. These processes include (Lamm et al., 2007): (a) stimulus encoding and mental image generation, (b) planning and execution of the mental rotation, (c) comparison (matching) of the rotated stimulus with the target stimulus, and finally (d) execution of the same/different response. Combining these two perspectives within the model allows us to deal with all the levels of complexity required by a mental rotation task (not only the processes “a-b” indicated above (mental rotation proper), but also “c-d” (control and exploitation of the mental rotation processes)).

To this purpose, the model leverages on the computational model “TRoPICALS” (Caligiore et al., 2008; 2010; 2012) developed to study affordance compatibility effects (Tucker & Ellis, 2001). The TRoPICALS model is a good starting point to design a model of mental rotation as it reproduces some key functions of the parietal-premotor circuit, which are crucial for stimulus encoding and extraction of object affordances (process “a”). TRoPICALS also includes important features of the prefrontal-premotor circuit, pivotal for managing other aspects of mental rotation (processes “c” and “d”). However, it cannot perform mental image rotations, as it lacks the necessary feedback circuits. In this respect, to address the core mental rotation process (process “b”) the model proposed here enhances the functions of TRoPICALS by developing two new key features. First, it is endowed with premotor-parietal feedback loops that allow it to implement mental rotation and sensory prediction based on forward models. Second, it

is endowed with an improved visual and motor system allowing it to scale up to more realistic 3D environments and robotic setups.

The rest of this section is organized as follows. Sec. 5.1.1 discusses the main features of the model, the learning algorithms used to train it, and the robotic set up used to validate it. Sec. 5.1.2 presents and discusses the results. Sec. 5.1.3 drives the discussion and proposes future work to improve the model.

### **5.1.1 Methods**

#### *A. Neural Architecture*

The model proposed here represents an operational hypothesis on how visual and motor neural processes might interplay during mental rotation. To this purpose it extends some features of the TRoPICALS model (Caligiore et al., 2010). Figure 5.1 shows the model architecture which consists of three main parts corresponding to specific areas of the brain mainly involved during mental rotation tasks (Lamm et al., 2007; Richter et al., 2000): the parietal cortex (PC), the premotor cortex (PMC), and the prefrontal cortex (PFC). These areas are represented by distinct neural maps activated using population code methods (Pouget, Dayan, & Zemel, 2003; Deneve, Latham, & Pouget, 1999). The population code hypothesis postulates that information, e.g., on stimuli and actions, is encoded in the brain on the basis of the activation of populations of neurons organized in neural maps, having a broad response field. In particular, each neuron responds maximally to a certain value of the variables to encode, and then progressively less intensely to values (based on a Gaussian function).

The neurons of the PC map (32 x 32 neurons) encode the shape and orientation of the object that has to be mentally rotated (Caligiore et al., 2013). The PMC consists of 2 neural maps PMC\_1 (31 x 105 neurons) and PMC\_2 (10 x 20 neurons), encoding motor

programs related to different arm parts (Wolpert & Kawato, 1998). PMC\_1 neurons encode a specific wrist posture of the robot corresponding to a specific object orientation encoded in PC. PMC\_2 neurons encode the two different hand postures that the robot produces to accomplish the mental rotation results (i.e., to indicate if two objects are same or different). In more detail, the model works with 2 different types of object, each with 13 different orientations. Therefore, the neurons of the PMC\_1 map encode 26 possible wrist postures.

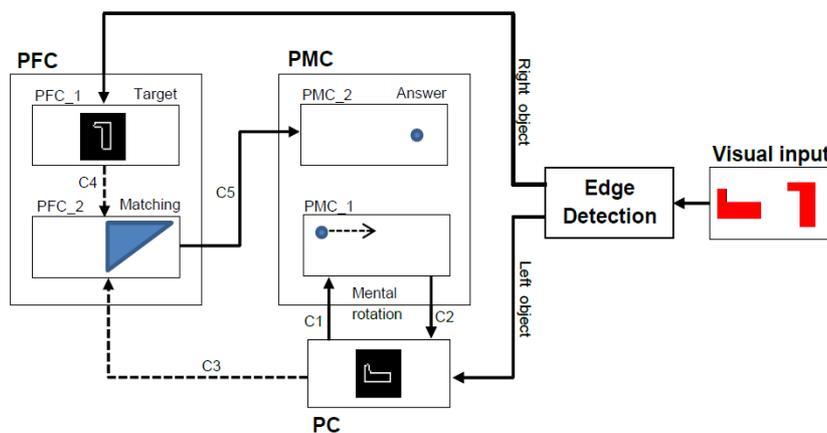

**Figure 5.1** The model of mental image rotation. Each box represents the model’s components. The arrows represent information flows from one component to another. The arrows accompanied by the letter “C” are the connections learned by SOM learning rule (dashed arrows) or by Hebbian learning rule (solid arrows). ©2013 IEEE

The PFC also has two maps, implementing the working memory (PFC\_1, 32 x 32 neurons) and the matching process area (PFC\_2, 32 x 64 neurons) (Fuster, 2001). The visual input for the model is the image of a simulated camera of one of the eyes of a simulated iCub robot. This image goes through an edge detection module to extract edge information of the two objects shown in front of the robot. The edge information for the object on the left will be passed to the PC, while the one for the “target object” on the right will be for PFC\_1. The target object is used as a reference for rotational purposes. The robot has to mentally rotate the object encoded by PC to check if it is the

same or it is different with respect to the target object stored within PFC\_1. PFC\_2 is the core for the matching process. It is formed by a Kohonen self-organizing map (SOM) (Kohonen, 2001) which takes inputs from the PC and PFC\_1. A major processing characteristic of the SOM is clustering. It transforms high dimensional inputs into low dimensional ones. Each input will then be represented in a unique area in the SOM map. We exploit this characteristic to create a neural map that represents pairs of stimuli. At the end of the matching process, PFC\_2 neurons trigger PMC\_2 activation whose neurons in turn encode the answering behaviour.

The mental rotation process is mainly based on the interactions between the PC and the PMC\_1. Consistently with the concept of affordances, the visual features of the object (shape and orientation) encoded by the PC cause a specific cluster of neural activity in PMC\_1. This pattern encodes the motor response to the seen object (i.e., a specific wrist rotation either clockwise or counter-clockwise, represented in terms of the posture assumed by the robot's wrist). Conversely, the PMC\_1-PC circuit works as a forward model, based on which cluster of activity in PMC\_1 causes a change of the image orientation in the PC.

### *B. Learning process*

Connections between maps are trained using Hebbian learning and SOM competitive learning. Hebbian learning is widely accepted as a biologically plausible learning mechanism mainly involving cortical areas (Doya, 2000). This learning mechanism underlies some developmental phenomena. One example is the critical period of learning (Munakata & Pfaffly, 2004), where synaptic efficacy cannot be modified and re-form after it has been settled.

At the beginning of the simulation, the weights of all the connections (C1, C2, C3, C4, and C5) are randomly set within the range [0, 0.1]. Then the simulated mental

rotation experiment follows 4 steps: 1) Stimulus encoding, assigning the edge information of the left stimulus to PC. 2) Execution of the mental rotation, repeating the interaction between affordances (PC-PMC<sub>1</sub> circuit) and forward model (PMC<sub>1</sub>-PC circuit; C1, C2 connections) processes. 3) Comparison, performing the matching process of the mental image and the target image in the SOM map (PFC<sub>2</sub>; C3, C4 connections). 4) Answer triggering, executing of the same/different response (PFC<sub>2</sub>-PMC<sub>2</sub> circuit; C5 connection).

The connections C1 are used to simulate affordance learning through the transformation of information from PC to PMC<sub>1</sub> (Fagg & Arbib, 1998). The training set consists of pairs of the left stimulus (within PC) and a specific cluster of activity (Gaussian tuning curve) which represents the affordance provided in PMC<sub>1</sub> (i.e., the robot's wrist angle). For each pairs, the C1 connections are trained by using the Hebbian learning rule (Eq. 4.1).

After training C1, an image of an object from the PC causes a specific cluster of activity in PMC<sub>1</sub>, that represents a wrist posture. Through training the network learns how to rotate the robot's wrist corresponding to the orientation of a seen object.

The connection C2 is responsible for forward model learning. In contrast to the affordance processing, this connection causes the formation of an image representation in PC from the cluster of activity in PMC<sub>1</sub>. For instance, a cluster of activity in PMC<sub>1</sub> that is caused by an image of object rotated 90 degrees in PC (during affordance processing) causes a 75 degrees rotated image back in PC. This training strategy allows the network to create a series of rotating images. Note that the training set causes an image to gradually change to become the same as an image of object of 0 degrees. This corresponds to the central position in PMC<sub>1</sub> map, which refers to the target position. When a rotation of an input image is greater than 0 degrees, the image

will be rotated on the right (clockwise). In contrast, if the angle is less than 0 degrees, the image will be rotated on the left (counter-clockwise). The C2 connections are also trained with the Hebbian learning rule.

The process of mental image rotation consists of the repetition of the interaction between the affordance process (connection C1) and the forward model process (connection C2), until an image in the PC reaches the 0 degrees target rotation. Each cycle of the interaction causes a rotated image, which can be considered a mental image because the actual input object orientation does not change.

The connections from PC and PFC\_1 to SOM PFC\_2 (C3, C4) are responsible for the matching process. When the network generates a mental image in the PC, having a 0 degrees rotation, then the process of learning is triggered. The connections link two maps, one is PFC\_1 (target image), which is set at the beginning of the simulation, and another is PC (the mental image). A training set for PFC\_2 is a combination of all the possible neural representations for the stimuli of each input. A neural activity in PFC\_2 forms a salient cluster with respect to the two specific inputs. As there are two possible images in each map, four clusters will be formed. To train PFC\_2, the SOM learning rule (Eq. 4.3) was used.

The PFC\_2 SOM map is trained in advance. In this way, a response of PMC\_2 can be fixed for each input couple from PC and PFC\_1.

The answer triggering process uses the connection C5 from PFC\_2 to PMC\_2. When two images are “similar” the robot chooses the “YES” answer, otherwise it chooses the “NO” answer. The term “similar” means “it is approximately the same”. The mental rotation ends when the position of cluster of activity in PMC\_1 is close to the central position. The most salient cluster in PFC\_2 is used to produce the answer. Given the four possible combinations of inputs in the matching process, two of them are

responsible for a "SAME" answer, while the remaining two for the "MIRROR" answer. Therefore, two regions in PFC\_2 with respect to the same image from the PC and PFC\_1 cause one cluster in PMC\_2. While two other regions within PFC\_2 represent different images of the two input maps. In this process, PMC\_2, is responsible for the answer triggering, the motor response to press two answer buttons or to produce some utterance such as "YES" or "NO". In the current version of the model this motor command is still not used to supply a control signal for the iCub but is directly interpreted as the response of the system.

After learning, an action potential of each neuron in the PMC\_2 map is calculated by using a dynamic competition method (Doya, 2000). As the connections within a neural map are based on an all-to-all pattern, each neuron in the map sends/receives signals to/from every neuron. The dynamic competition process causes dynamic activities within the map, based on a distance between neurons following the rule of long-range inhibition and short-range excitation. Neighbouring neurons which are activated with high potential will receive excitatory signals and tend to form clusters of activity. In contrast, the neurons which are far from the active neuron in the neural space will receive an inhibition signal and their action potential will be depressed.

The dynamic competition is also used as a method to calculate an agent's response time, e.g., to compare the model results with reaction time data in psychology experiments. Unlike a simple feed-forward process in layered neural networks, the dynamic competition process will be repeated until the action potential of at least one neuron in the neural map reaches a specific threshold. This process can be used to calculate the response time based on the action potential of an individual neuron that is most sensitive to a particular input. In detail, the number of repeating dynamic competition processes was recorded and used as a simulated response time. One cycle

of repeating the process will be assumed to be equal to 1 millisecond (Caligiore et al., 2008).

### *C. The simulated participant (the iCub robot)*

According to the view of embodied cognition (Pecher & Zwaan, 2005; Pezzulo et al., 2011), our cognitive capabilities to recognise and understand things have been shaped by the interaction processes between body, brain and environment. In addition, cognition is based on internal representations and simulations of real world actions and our perception (Barsalou, 1999).

Cognitive robotics platforms, such as humanoid robots, are being increasingly used to model embodied cognition and cognitive development in humans by means of embodiment (Caligiore et al., 2008; 2010; Cangelosi & Schlesinger, 2015). Following this approach, a simulation model of the humanoid robot iCub was used to model psychological experiments on the embodiment bases of mental rotation.

Each arm of the iCub has 16 joints. This experiment uses the joint number 5 of the right arm which directly affects the robot wrist's angle. If the robot holds an object with the right hand, rotating the wrist will only change orientation in the object plane.

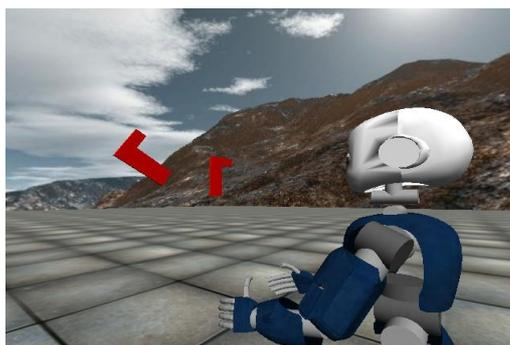
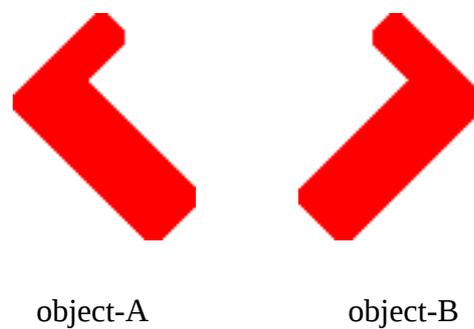

**Figure 5.2** The iCub simulator and its environment. ©2013 IEEE

### *D. Stimuli and Simulated Mental Rotation Task*

The visual stimuli use an abstract object, coloured in red, similar to an upside down letter L as shown in Figure 5.3. In this experimental set up, two versions of these stimuli

are used, each producing a mirror image of the other, and will be called object-A and object-B. The objects are displayed in the space in front of iCub simulator (Figure 5.2). During the process of affordance training, only one stimulus is shown in the left position, with the experimenter varying the orientation of the object and assigning a corresponding target position of the robot's wrist angle. In the testing session, two stimuli are displayed in the left and in the right positions. In each trial, the rotation of the left image is systematically varied, while the right one is presented with a 0 degrees orientation and can involve the two objects A and B.



**Figure 5.3** The two stimuli used for the simulated mental rotation task. Both stimuli are coloured in red for edge detection. ©2013 IEEE

The edge detection method is used as an early visual processing stage. The image is centred on a single object, and the red colour filter is applied. The edges of the object are extracted with the Canny edge detection technique (Canny, 1986), using the OpenCV library. The output from the edge detection process consists of binary data which can be directly assigned as an activity level to PC and PFC\_1 at the beginning of the simulation. Note that the eye position of the iCub was fixed, the object of interest will be extracted and put in the centre of the image maps e.g., V1 throughout the experiment.

Regarding the motor response, there is a limitation of the iCub's wrist angle, which can rotate in the range of  $[-90; 90]$  degrees. Counter-clockwise orientations are indicated by positive values, while clockwise orientations are indicated by negative

values. For example, in Figure 5.3 object-A has a 45 degrees orientation while object-B a -45 degrees one.

### 5.1.2 Results

The right object is always shown at a 0 degree rotation, while the left object can vary in orientation between 90 and -90 degrees. Therefore the maximum angular disparity between the two stimuli is 90 degrees. Varying them by 15 degrees (0, 15, 30, 45, 60, 75), as we did, this will typically require a maximum mental rotation in the map PMC\_1 of 6 steps. However, in the experiment the maximum number of rotation cycles is set to 10 as in some cases the model cannot rotate the image to a preferred orientation at the first cycle, thus requiring extra rotations. When the number of rotation cycles is equal to 10, it indicates that the model cannot correctly perform the mental image rotation of the left stimulus and will be forced to do the next step (matching process) by using the last image. The interaction between affordance and forward model processes leads the model to obtain a linear relationship between the angular disparity and a number of steps used in rotation.

The experiment is conducted using two groups of inputs, one for a recognition test and another for a generalization test. In the recognition test, orientations of the left stimulus are the same as in the training set by varying 15 degrees per pattern from 90 to -90. As there are two possible objects and each of them can have 13 possible orientations, this test has exactly  $13 \times 4 = 52$  different pairs of stimuli to be used as input. The generalization test refers to testing the model with unseen orientations. The left stimulus in this test changes 5 degrees from 90 to -90 but skip the cases of repeated values of the previous test. Therefore, the generalization test has  $(37 \times 4) - 52 = 96$  pairs of stimuli to be used as input. Both tests were repeated 52 times to record the consistency of the model performance. The result shown in Figure 5.5a is a series of mean values of

response time of the recognition test.

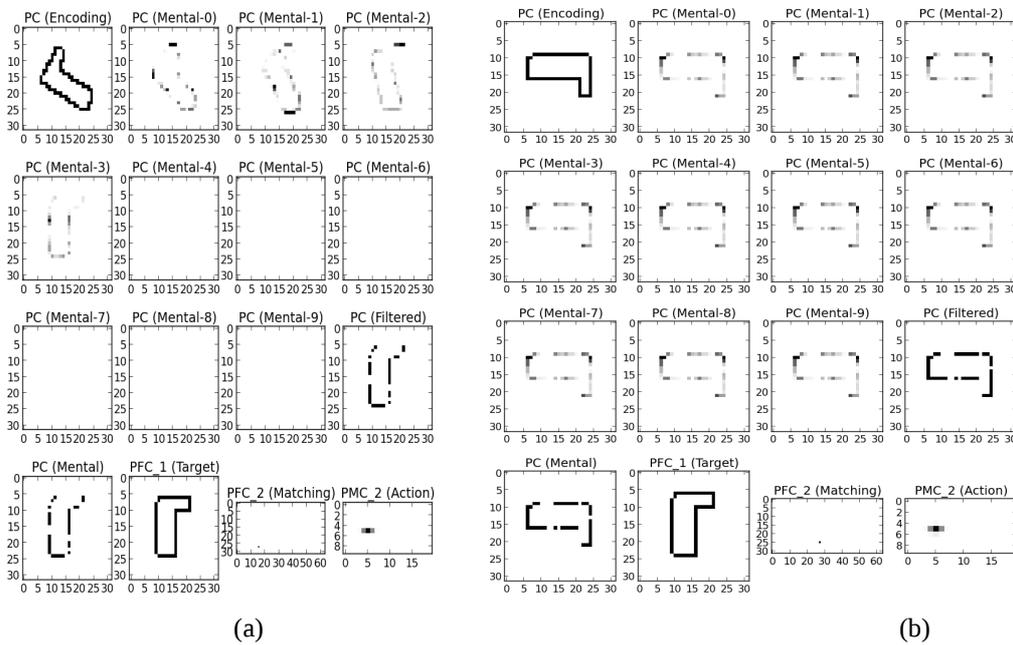

**Figure 5.4** Mental image rotation steps. a) Rotational steps in the case that the model is able to create a series of image changes to reach the 0 degrees default orientation; b) the model is unable to rotate the seen object. ©2013 IEEE

Figure 5.4a shows the mental rotation steps (PC) and the matching (PFC\_2) and answering (PMC\_2) processes for a successful trial. In this example the mental rotation process takes 4 steps to rotate an image of a stimulus of 60 degrees to an image of stimulus of 0 degrees. The mental rotation process ends when the rotated image reaches 0 degrees orientation. After that, the matching process within PFC\_2 is performed by using as input, the neural activity of target image in PFC\_1, and the rotated image in PC. The neural activation representing the matching process within PFC\_2 is showed in the third column of the last row in Figure 5.4a. The answering process of PMC\_2, is indicated in the fourth column of the last row on Figure 5.4a. The cluster of activity formed in the left side of the map will cause the answer "YES" to be chosen. The blank panels indicated that the rotational steps needed in this sample are less than 10.

In contrast, Figure 5.4b shows one case in which the model cannot rotate the left stimulus of -90 degrees of object-A into the 0 degrees default position. The model fails to rotate the image within 10 cycles, and has to do the matching process by using the last (un-rotated) image in PC. This scheme is similar to a guessing process in human subjects, when the time to do a mental rotation task is over. When the model fails to rotate the image after 10 cycles: each cycle, the image in the PC is the same. This case might be caused by a similarity effect of the edge information of objects in the training set. Indeed, the edge information of object-A and object-B of 90 and -90 degrees which are similar in pattern, as they mostly lie on the horizontal axis in the centre of the map. This means the model has to learn to match 4 similar inputs related to 4 separated clusters (on the left-most or right-most of the map). Hence, the model cannot learn to match the case of object-A of -90 degrees to a correct cluster. Therefore, when the left stimulus is object-A of -90 degrees, the affordance process causes a cluster of activity in PMC\_1 which is not exactly the preferred position (it is a nearby position). Then the forward model, using that cluster, causes the same image back in the PC.

The model has successfully reproduced the findings of human subjects in a typical mental rotation task. Indeed, in experiments with human RTs profile often shows an inverse v-shaped profile as the one found in the simulations we ran. Fig. 5a shows the RTs profile of the recognition test where the model performed simulated mental rotation tasks with different orientations of the left stimulus. From the figure it is possible to observe how RTs increase as the angular disparity increases.

As indicated by the RTs profile, the mental rotation performance with the object-A produces higher RTs than with object-B. This characteristic is affected by the training strategy that fed a sequence of patterns in the training sets. The patterns of object-A are fed into the network in a training period before object-B. This makes the model more

sensitive to object-B than to object-A. However, this characteristic might be prevented by using a random feed, instead of a sequential feed of training patterns. This behaviour of the model might be also considered a prediction for a possible experiment with real subjects, where these are allowed to manipulate different objects at different times before the test.

The recognition test achieves 98% correct answers (51 out of 52) on rotating object A and 100% on rotating objects B. While in the generalization test with unseen orientations, the success in rotation is 95.8% (92 out of 96) and 96.8% (93 out of 96) respectively for object B and object A. These results are always the same, over 52 trials. The overall success rate is 96.6%. The angular disparity between the two stimuli affects the response time of the model in the same fashion as human subjects. Increasing the difference in degrees of rotation causes the model to require a higher number of rotating cycles: this increase the simulated response time. The experimental result show that the model can rotate most of the possible pairs of objects except for one case of object-A of -90 during recognition test, 2 cases of object-A of -85 and 70, and 2 cases of object-B of 55 and 70 degrees during the learning stage. Dash circles in both graphs of Figure 5.5 are used to point an orientation of the stimulus that cannot be rotated. When an image of that stimulus is shown, the model cannot change it into a new preferred image rotated 15 degrees.

The Figure 5.5b reports the comparison of RTs profiles between the recognition test and generalization test on object-A. The figure indicates that some unseen orientations in the learning test took more RTs than ones in the recognition test, although the disparity is smaller. At each step of image rotation, a new image is gradually changed approaching the 0 degrees target object rotation. When the model is shown an unseen object orientation, this causes longer reaction times due to the intermediate angle of

rotation not matching the discrete 15 degrees increment images shown during training. For example, when the model is shown an image with 55 degrees rotation, the RTs will be greater than the performance of 60 degrees one. This is because at first the model keeps rotating the image of 55 degrees stimulus into an image of 60 degrees stimulus for some steps (55 is closer to 60 than 45 according to the training patterns), and only after doing this it goes back to follow the incremental 15 rotating strategy.

The reasons leading the model to produce a noisy RTs profile for the generalization test (Figure 5.5b) could be explained as follows. If in the first cycle the starting image in PC is unseen the feed-forward process, through the connection C1, could activate a neural cluster within PMC\_1 representing an unpredictable position. As a result, the mismatched salient cluster in the map PMC\_1 creates an incorrect image back to the PC. These processes are repeated, by chance, and the mental rotation ends when the position of the cluster of activity in PMC\_1 is close to the central position. This process leads the model to produce a noisy RTs profile for the generalization test as shown in Figure 5.5b. To sum up, the similarity of unseen object orientations of the training patterns is the main explanation for this effect. However, this is a common effect that can be found when working with neural networks. One way to solve this effect is to use more precise training patterns.

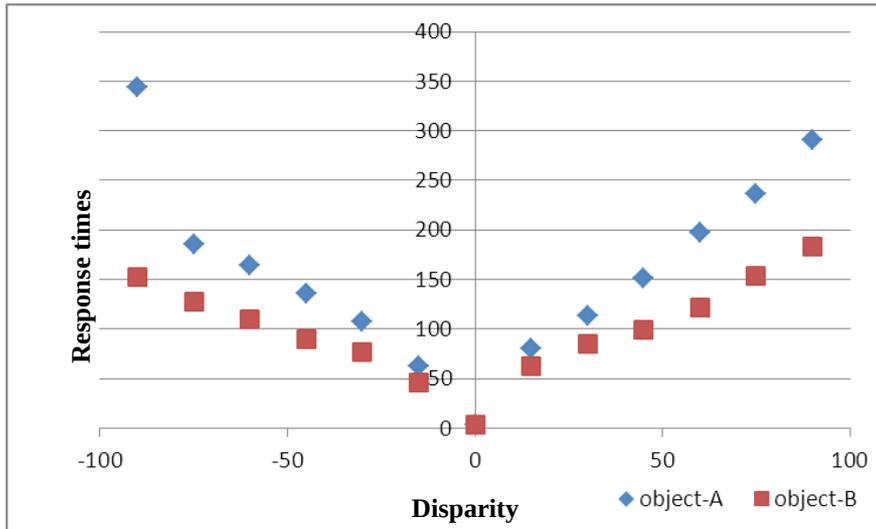

(a)

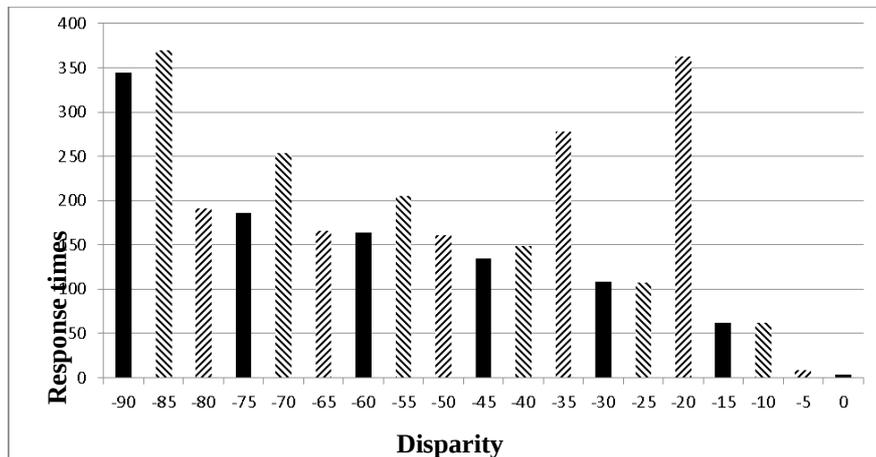

(b)

**Figure 5.5** RTs profiles of the simulated mental rotation task. (a) The rotation of different stimuli affects the RTs profile; (b) Series of some unseen (gray bars) and seen (black bars) stimulus orientations of object-A; notice that some unseen orientations (-85, -70, -55, -35, -20) show greater RTs than ones in the training set (-90, -75, -60, ...). ©2013 IEEE

### 5.1.3 Discussion

The model proposed in this chapter accounts for the mental rotation processes based on neural mechanisms involving visual imagery, affordance encoding and forward models

processing. In this respect, the proposed approach is in agreement with the theoretical and empirical research on mental rotation, about the interplay between covert motor processes and the creation of a mental image during mental rotation task. Remarkably, the model is validated within the simulated humanoid robot iCub engaged in solving a typical mental rotation task.

The model also presents some limits which are however, all addressable in future work. Here we briefly discuss the main limitations and propose a solution for each of them. First of all, in the current version of the model mental rotation mainly depends on the interplay between affordance and forward model processes, ignoring the role of the wrist proprioceptive signals. This means that the robot's wrist movements do not influence the mental rotation processes. Recent research (Chu & Kita, 2008; 2011) points out that the performance of mental rotation tasks can be improved by the assistance of hand movements, or gestures called “co-thought gestures”. These studies also suggest that spontaneous gestures during performing mental rotation task provide a rich sensorimotor experience of the solving strategy in human subjects. Gestures improve the internal representation of a spatial transformation of objects. Following this hypothesis, we will modify the current model by adding proprioceptive units that should act as an internal representation of gestures or hand movements. In more details, we will introduce a more direct effect of proprioception on mental rotation by modifying the parietal area by introducing a somatosensory map (SS) whose neurons encode the proprioceptive signal. SS might be a dynamical field map (Erlhagen & Schöner, 2002) combining the forward model signal with the proprioceptive signal. When the two signals are different there would be an interference effect and the dynamical competition would take more time to be solved (increasing RTs). The new version of the model should be able to account for other data which link overt movements and mental

rotations (Wohlschläger & Wohlschläger, 1998; Wohlschläger, 2001).

Secondly, humans can create mental images and perform mental image rotation on a variety of objects, even on unseen abstract object (Shepard & Metzler, 1971; Wexler, Kosslyn, & Berthoz, 1998). Unlike humans, the model proposed here can only work with the objects of a training set. However it should be able to work with any kind of object. This will be done by separating the object orientation from the “object identity”. We think that this could be possible using an inferotemporal cortex (IT) map whose neurons encode objects independently of their orientation, similarly to what happens in humans. This map could be connected to PC together with SS (encoding the posture proprioceptive signal): this would allow PC to encode the combinations of object identity (IT) and particular wrist posture (SS) so as to allow the system to imagine the rotation of any type of object after being suitably trained.

Overall, also considering these possible improvements, the proposed neuro-robotic model of mental rotation provides a useful computational framework to study the integration between mental rotation capabilities and embodied cognition.

## 5.2 Experiment 2: Motor Processes and Mental Rotation

In this experiment, we propose a new model that can address one of the two key issues raised in the previous study (i.e., proprioception). This investigates the inclusion of overt wrist movements during performing a mental rotation task, as it had been suggested that, in humans, movements of the hands can help increase performance of solving a typical mental rotation task.

### 5.2.1 Methods

#### *A. The simulated mental rotation experiment: task, participant, and stimuli*

A mental rotation task used in this work follows the typical mental rotation tasks that have been used in the field of experimental psychology, for example by Shepard & Metzler (1971), Chu & Kita (2008; 2011). The goal is to let a simulated participant make a judgement on whether a pair of stimuli is the same or a mirror version of each other. The stimuli are stylized geometrical shapes. At each trial, the stimuli can change in terms of object type and orientation. After the simulated participant produces an answer, a new trial will be started by changing the current pair of stimuli and/or their rotation.

The simulated humanoid robot iCub (Tikhanoff et al., 2008) was used as a participant to model the targeted psychological experiments. The iCub simulator provides visual perception via simulated cameras and can perform actions corresponding to specific motor commands. During the mental rotation task the model has to compare two visual stimuli having different orientations as in the target experiments.

Within the perspective of embodied cognition, the robot platform used in this work provides to the model with perception and action capabilities through simulated cameras and motor outputs. Here a small subset of the sensorimotor possibilities of the iCub simulator was used to demonstrate the possibility of performing the mental rotation task within a robotic embodied setup. However, in future work we will consider the implementation of more complex mental rotation tasks and the role of gestures. In these cases, the rich perception and multiple degrees of freedom of the iCub platform will allow the investigation of sophisticated cognitive skills related to object recognition, management of mental images (creation/rotation), and problem solving.

During the experiment, pairs of target and comparison object images having different orientations are used. The objects are displayed in the space in front of the iCub. For the training, the rotation of the comparison object is varied by  $30^\circ$ , so that each stimulus can assume seven orientations ( $-90^\circ$ ,  $-60^\circ$ ,  $-30^\circ$ ,  $0^\circ$ ,  $30^\circ$ ,  $60^\circ$ ,  $90^\circ$ ). During the process of affordance training, only one comparison stimulus is shown in the left position, with the experimenter varying the orientation of the object and assigning a corresponding position for the robot's wrist angle. In the testing session, two stimuli are displayed, the comparison stimulus at the left and the target stimulus at the right positions.

After training, the generalization ability of the model is tested using 196 pairs of stimuli supplied in sequence. The experiment has been repeated 10 times to test the consistency of the model. Each time the pair of stimuli is changed, the model internally rotates the left stimulus to match it with the right one and produce an answer. Three types of information are recorded during the experiment: the RTs, which are the result of a neural dynamical competition (see Sec. C. and cf. Caligiore et al., 2010, and Erlhagen & Schöner, 2002); the answer for the current mental rotation task (see Sec.

C.); the successful degree of rotation (see Sec. C.). When the number of rotation cycles reaches 10, this indicates that the model cannot correctly perform the mental image rotation of the left stimulus and so it is forced to do the matching process by using the last rotated image.

### *B. Neural Architecture*

The neural network model (Figure 5.6) proposed in this experiment investigates an operational hypothesis about the interplay of the visual and motor neural processes during mental rotation. To this purpose, the model extends some features of the TRoPICALS model. TRoPICALS (Caligiore et al., 2010; 2013) is a computational model of affordance control designed to account for action-language and stimulus-response compatibility effects studied experimentally in cognitive psychology (Tucker & Ellis, 2001; 2004) It does this based on an architecture that considers prefrontal cortex as a key source of the top-down control of the areas that participate to the selection of affordances and execution of actions.

The account of compatibility effects given by TRoPICALS is based on four general brain organisation principles incorporated in its architecture (Caligiore et al., 2010): (a) the two-route organisation of the sensorimotor brain into the ventral and a dorsal neural pathways; (b) the guidance of action selection based on prefrontal cortex “instructions”; (c) the selection of actions within premotor cortex based on a neural competition between different affordances with bias from prefrontal cortex; (d) the capability of language to trigger internal simulations of the referents of words (Barsalou et al., 2008). The acronym “TRoPICALS” summarises these principles: Two Route, Prefrontal Instruction, Competition of Affordances, Language Simulation. The model reproduces compatibility effects on the basis of the agreement or disagreement (compatibility or incompatibility) of the top-down bias from prefrontal cortex with the available

affordances of objects as this produces respectively fast or slow reaction times. TRoPICALS provides a broad framework to account for several types of affordance related compatibility effects involving grasping, reaching and language, and is capable of generating novel testable predictions, including some predictions on the possible outcomes of compatibility experiments with Parkinson patients (see Caligiore et al., 2013; the latter predictions are relevant as Parkinson patients have damaged excitatory and inhibitory neural circuits linking the prefrontal cortex to the premotor cortex via supplementary motor cortex).

The architecture of the model presented here is shown in Figure 5.6. It consists of four parts corresponding to the main areas of the brain involved in mental rotation tasks (Lamm et al., 2007; Richter et al., 2000): the parietal cortex (PC), the premotor cortex (PMC), the prefrontal cortex (PFC), and the primary motor cortex (M1). The dorsal pathway through the circuit PC-PMC is responsible for the “how” sub-task in this case, i.e., for the pre-activation and selection of affordances of the seen objects. The ventral pathway via PC-PFC is instead the circuit that recognizes objects (“what” sub-task). The matching and answer triggering processes are the result of the integration of the maps PC, PMC, and PFC. The M1 is responsible for overt control of the robot's wrist movement. Repeating processes within PC and PMC drive mental image rotation, which is supported by the interaction between affordance processing and forward model actions. The proprioceptive input from the robot's wrist posture (PC) plays a key role in the forward model used during mental rotation.

Each cortical area is formed by two neural maps encoding information using population code methods (Pouget, Dayan, & Zemel, 2003). Population code methods claim that information (e.g., on stimuli and actions) is encoded in the brain on the basis of the activation of populations of neurons having a broad response field and

topologically organized in neural maps. In particular, each neuron of a map responds maximally to a certain value of the variables to encode, and then progressively less intensely to less similar values (based on a Gaussian-like function).

PC is formed by two distinct areas: the posterior-parietal cortex (PP) and the somatosensory cortex (SS). The neurons of the PP map (32 x 32 neurons) encode the shape and the orientation of the object that has to be mentally rotated (Rizzolatti & Craighero, 2004).

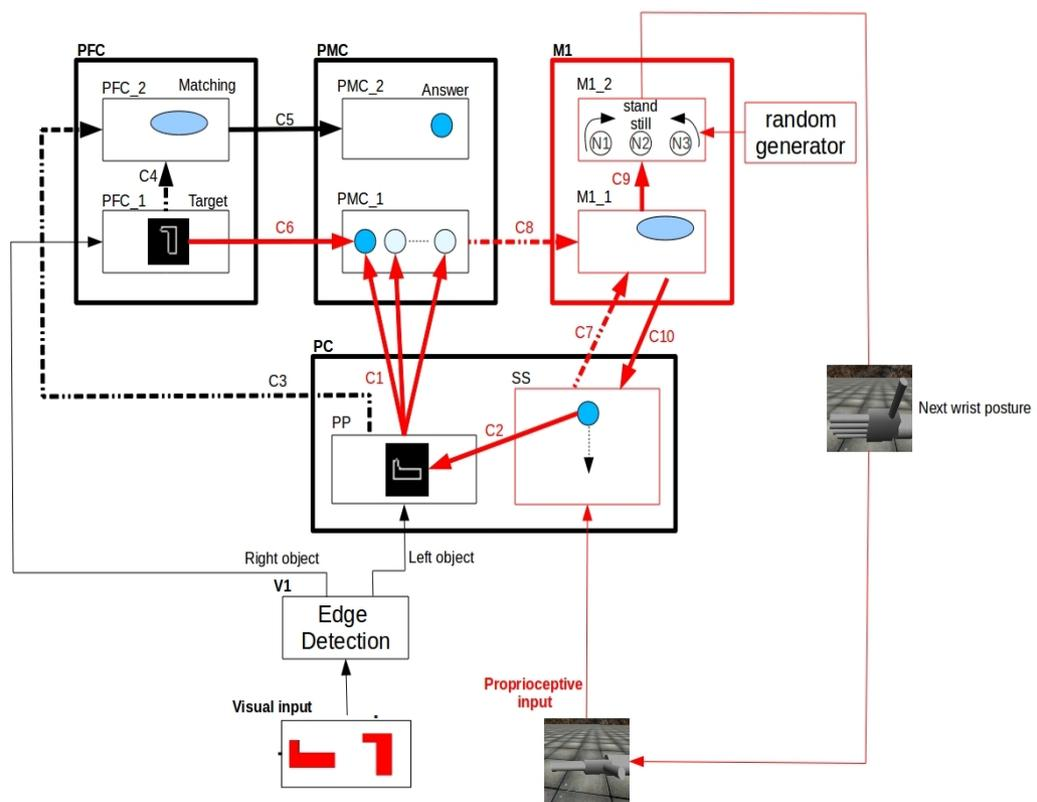

**Figure 5.6** The model of mental image rotation. Each box represents the model’s components. The arrows represent information flow from one component to another. Arrows accompanied by the letter “C” are the connections learned by SOM learning rule (dash-dot arrows) or by Hebbian learning rule (solid arrows).

The neurons of the SS map (31 x 100 neurons) elaborate the proprioceptive signal related to the robot wrist orientation (Caligiore et al., 2010). The PMC region is formed

by 2 neural maps PMC\_1 (31 x 100 neurons) and PMC\_2 (10 x 20 neurons). The two maps encode motor programs related to different arm parts (Rizzolatti & Craighero, 2004; Caligiore et al., 2008): PMC\_1 neurons encode the wrist posture of the robot corresponding to the object orientation encoded in PP. PMC\_2 neurons encode the hand posture that the robot produces to accomplish the mental rotation results (i.e., to indicate if two objects are same or different). The PFC (Fuster, 2001) also consists of 2 maps implementing a working memory encoding the target stimulus (PFC\_1, 32 x 32 neurons) and performing the matching process (PFC\_2, 64 x 64 neurons; cf. Baldassarre, 2002, and Baldassarre, 2003, for an embodied neural-network model of planning based on visual imagery and using a goal-matching mechanism).

The visual input for the model is the captured image from one “eye” (camera) of the simulated iCub robot. The edge information for the object on the left is passed to the PP, while the one for the target object on the right is sent to the PFC\_1. The target object is used as a reference for the rotational process. The robot has to mentally rotate the object encoded by PP and check if it is the same or it is different with respect to the target object encoded in PFC\_1. For each image, PP pre-activates all possible wrist postures in PMC\_1. This pre-activation is equal to 0.2 and represents the possible actions afforded by the current image in PP. At the same time, PFC\_1 supplies a bias signal to PMC\_1 to lead to the full activation, equal to 1.0, of one desired final wrist posture among the ones afforded by PP. This posture corresponds to the desired final orientation of the object that the robot has to (mentally) accomplish to overlap the image within PP with the target image within PFC\_1. In parallel with these processes, the PFC\_2 performs the matching process. PFC\_2 is formed by a Kohonen self-organizing map (SOM; Kohonen, 2001) which takes inputs from PP and PFC\_1 and represents each possible combination of their activation as a whole cluster. This represents the current situation

used by PFC to decide what to do (cf. Caligiore et al., 2010). The winning clusters of PFC\_2 cause the PMC\_2 activation, in turn encoding the answer of the system.

M1 consists of two areas M1\_1 and M1\_2. M1\_1 is a SOM map (64 x 64 neurons) responsible for encoding a combination of the current posture from SS and the desired posture from PMC\_1. The neural activation of M1\_1 feedbacks to SS as reference copy of the motor program during the mental rotation process (see below). M1\_1 also triggers a wrist rotation movement through M1\_2. M1\_2 is a neural array formed by 10 x 30 neurons grouped in three separated clusters (N1, N2, N3). The activation of N1 causes a 30° clockwise rotation of the wrist; the activation of N3 causes a 30° counter-clockwise rotation of the wrist; the activation of N2 does not lead to any rotation of the wrist.

### *C. The simulated mental rotation process*

This section briefly summarizes how the model reproduces the mental rotation processes. The following points refer to the model functioning after the learning processes, illustrated in Sec. D., have terminated.

#### *Affordance-based action pre-activation (C1):*

The left object image encoded by PP neurons pre-activates all the possible write postures within PMC\_1 at the same time. Since one object could assume 7 different orientations, we have 7 different clusters of neurons pre-activated within PMC\_1. This affordance-based pre-activation of possible actions mimics the preparatory processes for actions present when people see an object.

#### *Action selection (C6):*

PFC\_1 supplies a bias signal to PMC\_1 to lead the full activation (with a level of neural activation of 1.0) of one affordance/action among the elicited ones so transforming it into the representation of a specific desired final wrist posture. This

cluster represents the desired posture that the robot has to (mentally) reach to mentally rotate and overlap the image within PP with the target image within PFC<sub>1</sub>.

*Mental rotation by the inverse model (C7, C8) and the forward model (C10, C2):*

The desired wrist posture encoded by PMC<sub>1</sub> and the current wrist posture encoded by the SS are combined within M1<sub>1</sub> (C7, C8). Together with C9 connections, this forms an inverse model (inverse models map the current state and the desired state into the action needed to move from the former to the latter one). M1<sub>1</sub> and SS form a forward model (forward models map the current state and planned action into the future state). In particular, the winning cluster within M1<sub>1</sub> evokes a cluster within SS corresponding to the next anticipated wrist posture (C10). In turn, this cluster within SS activates the new rotated image within PP (C2), so causing a mental rotation step. In particular, the connection C2 from SS to PP underlies the process of mental image generation based on the anticipated proprioception. After a specific proprioceptive cluster in SS has been formed, this causes the corresponding image back to PP so that a progressive sequence of clusters in SS will cause a corresponding progressive rotation of the image in PP.

In line with empirical evidence (Chu & Kita, 2008; 2011) the current proprioceptive signal that affects the mental rotation processes based on the activation of SS depends on both the signal from M1<sub>1</sub> (C10) related to the planned action. This process might be disturbed by the current actual posture that is does not move (Figure 5.6). In this respect, we assume that attention mechanisms not explicitly simulated here (Logan, 1996; Roelfsema, Lamme, & Spekreijse, 1998) might drive the system to be more focused on the mental rotation task rather than on the wrist condition. This assumption is supported by recent evidence showing the presence of reciprocal interference between mechanisms of mental rotation and the deployment of visual-spatial attention

(Pannebakker et al., 2011). The effect of the attention focus assumed here is simulated by setting (within SS) a weaker signal from current proprioception than from the forward model.

The mental rotation in this work is achieved through a training strategy that considers the angular difference between the two stimuli of the task. When the orientation of the left object is greater than that of the right target object, the model generates a mental image of the left object rotated 1 step (30°) clockwise. In contrast, the model performs a 1 step counter-clockwise rotation when the left object's orientation is smaller than the right one. The RTs expressed by the model, proportional to the discrepancy of orientation between the target and the rotated object, are strongly dependent on the specific mechanisms assumed here to perform mental rotation. These mechanisms are consistent with what might happen in the human working memory of subjects engaged in mental rotation tasks. The model always uses the last image in PP to perform the matching process. The maximum number of rotation cycles is set to 10, more than needed by a maximum rotation, as in some cases the model cannot rotate the image of one position in the first cycle and so requires extra rotations.

#### *D. Learning process*

Connections between maps are trained using Hebbian learning and SOM competitive learning (summarised in Table 5.1), which are widely accepted as biologically plausible learning mechanisms involving cortical areas (Doya, 2000). The specific Hebbian learning method used in this model is the Oja rule (Oja, 1982).

**Table 5.1** The parameters used in the network.

Connection	Type	number of patterns	Training cycles	Type of output
C1	Hebb	14	84	Cluster of activity
C2	Hebb	14	84	Image
C3 & C4	Kohonen	98	10,000	Cluster of activity
C5	Hebb	196	1,176	Cluster of activity
C6	Hebb	14	84	Cluster of activity
C7 & C8	Kohonen	196	10,000	Cluster of activity
C9	Hebb	98	1,960	Cluster of activity
C10	Hebb	98	1,960	Cluster of activity

Now we describe the training phases leading the model to perform the mental rotation task. Learning of the inverse model (C7, C8, C9) and of the forward model (C10, C2). The aim of the inverse model learning phase is to obtain the values of the connection weights between SS-M1\_1, between PMC\_1-M1\_1 and between M1\_1-M1\_2, needed to perform a wrist rotation (encoded by M1\_2) driving the current wrist posture (encoded by SS) towards the desired wrist posture (encoded by PMC\_1). The learning phase pivots on the following “motor babbling procedure” done with the object rotated by the robot: (a) The robot assumes a random wrist posture within  $[-90^\circ, 90^\circ]$ , which is encoded by a Gaussian cluster within SS; (b) The random generator randomly decides the direction of rotation (DR) and the number of rotations (NR). For example, if  $DR = 1$  and  $NR = 3$ , the robot rotates its wrist clockwise through  $90^\circ$  ( $3 \times 30^\circ$ ).  $DR = 1$  causes the activation of the neuron N1 of M1\_2.  $NR = 3$  implies that N1 is activated for three sequential steps. We assume that “one time step” is the time the robot needs to rotate its wrist through  $30^\circ$ ; (c) The value of the wrist rotation is used to compute the total rotation (in this case  $3 \times 30^\circ = 90^\circ$ ) and, based on the current posture, this is used to activate the PMC\_1 map as a possible desired wrist posture; (d) PP neurons encode the current object orientation; (e) At the end of each step the Kohonen rule is used to update the connection values (C7, C8) in order to obtain different cluster within the M1\_1 representing all the combinations of the desired final wrist posture (PMC\_1) and the current wrist posture (SS); (f) Aside the SOM M1\_1, at the end of each step we also

train the forward model (C10, C2). Each SOM cluster (M1\_1) is associated by the Hebbian rule, with the following wrist posture cluster (SS) which is in turn associated (Eq. 4.1), with the corresponding object orientation (PP) (this corresponds to performing a rotation with an object in the hand and associating the felt proprioception with the seen object image); (g) At the end of each step the clusters activated within the SOM M1\_1 are associated to M1\_2 activated neuron (C9) using Eq. 4.5. The use of the SOM M1\_1 is necessary to learn all the possible combinations between current posture (SS), the desired posture (PMC\_1), and control signal (M1\_2) needed to accomplish the desired posture. Overall there are 7 possible desired postures encoded in PMC\_1 and 7 x 14 possible combinations to be encoded in M1\_1.

*Learning the affordance-based action pre-activation (C1):*

The training pattern is formed by 2 series of rotating images which differ by 30 degrees of orientation per step. Each image is loaded in PP as the activity level of a set of neurons in the map. The aim of the training process is to create a mapping between the input image (PP) and the corresponding wrist postures of the robot encoded by a cluster of active neurons (Gaussian tuning curve) within PMC\_1. The signal from PP pre-activates the clusters within PMC\_1 with a value of 0.2 (this activation is obtained by opportunely setting the maximum value of the C1 connection weights). This means that the object can pre-activate several actions based on the seen object affordances. The signal from PFC\_1 allows the full activation, and hence the selection, of one cluster (one desired posture) according to the organism's goal, in our case the target image within PFC\_1. The training process is implemented using the Hebbian learning rule (Eq. 4.2).

*Learning action selection (C6):*

The training pattern is formed by 2 series of rotating images which have a 15°

different orientation per step. Each image is loaded into the PFC\_1 map as the activity level of a set of neurons in the map. An important difference with respect to the pre-activation of affordances training phase discussed above, is that here the aim of the training process is to create a mapping (through Eq. 4.2) between the specific target image (PFC\_1) and the specific wrist posture of the robot encoded by clusters of activities (Gaussian tuning curve) within PMC\_1. In this way the signal from PP pre-activates within PMC\_1 all the 7 possible desirable wrist postures related to the seen object, whereas the signal from PFC\_1 supplies the crucial bias signal to select the desired wrist posture related to the target object.

*Learning the matching and the answering processes (C3, C4, C5):*

The connections from PP and PFC\_1 to the SOM PFC\_2 (C3, C4) are responsible for the matching process. When the network generates a mental image in the PP having the same orientation as the target image encoded by PFC\_1, then the process of learning is triggered. The connections link two maps: one is PFC\_1 (target image), which is set at the beginning of each mental rotation and then kept fixed, and another is PP (the current mental image). A training set for PFC\_2 is a combination of all the possible neural representations of PFC\_1 and PP. PFC\_2 forms a winning cluster of neuron for each two specific inputs. As there are 14 possible images in each input map, 196 clusters will be formed. To train PFC\_2 the SOM learning rule (Eq. 4.5) was used.

The answer triggering process uses the connection C5 from PFC\_2 to PMC\_2. When two images fed to PFC\_2 are similar the robot chooses the “YES” answer, otherwise it chooses the “NO” answer (the term “similar” meaning “approximately the same”). The mental rotation ends when the cluster of alternative neurons in M1\_2 is close to the “stay still” cluster (N2). When this happens, the most salient cluster in PFC\_2 is used to produce the answer. Given the 196 possible combinations of inputs in

the matching process, half of them are responsible for a "Same" answer, while the remaining half for the "Mirror" answer. Therefore, 98 regions in PFC\_2, with respect to the same image from the PP and PFC\_1, activate one cluster in PMC\_2, while the other 98 regions represent different images of the two input maps and so activate a second cluster. In the current version of the model, the PMC\_2 motor command is still not used to supply a control signal for the iCub but is directly interpreted as the response of the system.

After learning, an action potential of each neuron in the PMC\_2 map is calculated by using a dynamic competition method (Erlhagen & Schöner, 2002). To this purpose PMC\_2 is endowed with within-map all-to-all connections. The connections follow the rule of long-range inhibition and short-range excitation. This pattern of connections causes a dynamic competition process within the map. Neighbouring neurons which are activated with a high input will receive excitatory signals and tend to form a winning cluster of activity. In contrast, other neurons far from the winning cluster in the neural space will receive an inhibition signal and their activity will be depressed.

The dynamic competition is used as a method to calculate the agent's RTs so as to compare the model results with RTs data in psychology experiments (Caligiore et al., 2010). Unlike a simple feed-forward process in layered neural networks, the dynamic competition process will be repeated until the action potential of at least one neuron in the neural map reaches a specific threshold. The number of cycles needed to achieve this threshold is used as simulated RTs (one cycle is assumed to correspond to 1 real-time millisecond).

### **5.2.2 Results**

The two stimuli of the simulated mental rotation task were varied in seven angular positions in the range  $[-90^\circ; 90^\circ]$  with a step of  $30^\circ$ . Therefore, the maximum angular

disparity between the two stimuli was  $180^\circ$  and required six rotational steps to mentally overlap the left stimulus to the right target one. When the number of rotation cycles was equal to 10, this indicated that the model could not correctly perform the mental image rotation of the left stimulus and so it was forced to do the matching process by using the last image.

Figure 5.7a shows the mental rotation steps (PP) and the matching (PFC\_2) and answering (PMC\_2) processes for a successful trial. In this example the mental rotation process takes 5 steps to rotate an image of a stimulus at  $-60^\circ$  so as to match it to an image of a target at  $90^\circ$ ; both stimuli are object-A. The mental rotation process ends when the rotated image reaches  $90^\circ$ . After that, the matching process within PFC\_2 is performed by using as input the neural activity of the target image in PFC\_1, and the rotated image in PP. The neural activation representing the matching process within PFC\_2 is shown in the third column of the last row in Figure 5.7a. The neural activity within PFC\_2 shown in the figure is the level of action potential of each particular neuron (within the range 0.0-1.0). A salient cluster that is indicated by the black spot is the answer of the map. After applying a filtering process, the cluster with most activity in PFC\_2 is used as an input to PMC\_2. The answering process of PMC\_2 is indicated in the fourth column of the last row in Figure 5.7a. The cluster of activity formed in the left side of the map will cause the answer "YES" to be chosen. The blank panels in Figure 5.7a indicate that the rotational steps needed in this sample are less than 10.

In contrast, Figure 5.7b shows one case in which the model cannot rotate the left stimulus of  $0^\circ$  into the  $60^\circ$  position of the target stimulus: as indicated by the panels "Mental" and "Target" in Figure 5.7b, the final rotated object image is incorrect. The model fails to rotate the image within 10 cycles, and so is forced to trigger an action by using the last image in PP. This process is similar to a guessing process in human

subjects when the time to perform the mental rotation task is over. The model's failure of this case might be caused by a mismatch cluster in SS caused by a noisy cluster position in M1\_1.

Possible failures in rotation and response of the model mainly come from the map M1\_1 and connection C9 and C10. Because there are many possible patterns in M1\_1, these might overlap in part so generating incorrect or noisy activations in M1\_2 and SS. This property of the model simulates the error responses found in human subjects as a consequence of incorrect working memory reconstructions of the rotated object images.

After testing the model with all possible pairs of stimuli used in the training set, the model achieves a 97.95% (192 out of 196) success rate (rotation of the left stimulus to match the target). The overall percentage of correct responses is 85.7% (168 out of 196).

As indicated by the RTs profiles shown in Figure 5.8a, when the angular disparity is high the required number of cycles of rotation and RTs also increases. The angular disparity (x-axis) is calculated by using the difference in orientation between the two stimuli. A  $0^\circ$  disparity corresponds to the left stimulus orientation being equal to the one of the right target object (but can be from a different type of object). As indicated by the RTs profile, there is no significant effect from the different types of object that are used in rotation.

There are three types of errors incurred by the model. The first is from the situation where the model cannot rotate the left stimulus to match the right one within 10 rotational cycles. An error of this type causes a higher RTs than in normal cases, and also an incorrect response. Secondly, as the connections from SS to PP underlie mental imagery, a possible error in SS directly affects a mental image in PP. In some cases this leads to a successful rotation by chance. In detail, when active neurons in M1\_1 cause an incorrect cluster in SS, this might be the cluster that causes the image of the target. In

this case, the number of rotations will be less than usual. Last, even when the model can successfully rotate the left stimulus the answer might not always be correct. The first two errors are caused by a wrong neuron activity within M1\_1 while the last error is caused by PFC\_2.

As we mentioned before that important empirical evidence shows that mental rotation processes are embodied in that they involve the same brain structures involved in overt sensorimotor processes. In particular, various experiments show that the performance of overt actions interferes or facilitates mental rotation processes (Wexler, Kosslyn, & Berthoz, 1998; Wohlschläger & Wohlschläger, 1998; Wohlschläger, 2001). We ran an experiment with the model to start to investigate these phenomena, which are illustrated in the following.

The proprioceptive signal in SS has been simulated by using the current wrist angle of the robot. This process acts as a cluster pre-activating the map SS. When the position of the pre-activated cluster and of the cluster caused by M1\_1 are the same, or overlapped, this should support the rotational processes and so the RTs are expected to be reduced. In contrast, if they are different the dynamic competition process should take a longer time to activate the most salient cluster within the map.

The results, illustrated in Figure 5.8b indicate that the model produced different RTs profiles when matching, mismatching, or no proprioceptive signals were supplied (as in the simulations presented above) to SS. In the matching conditions the signal from the current wrist posture pre-activated the same cluster in SS as the one proprioceptive signal. In contrast, in the mismatching condition a random cluster is sent to SS, so the competition within SS has to use more cycles to form a salient cluster and this slows down the RTs. However, the perturbed proprioceptive input does not affect the accuracy of the response. Therefore, in the current setting the signal from the wrist proprioception

affects only RTs.

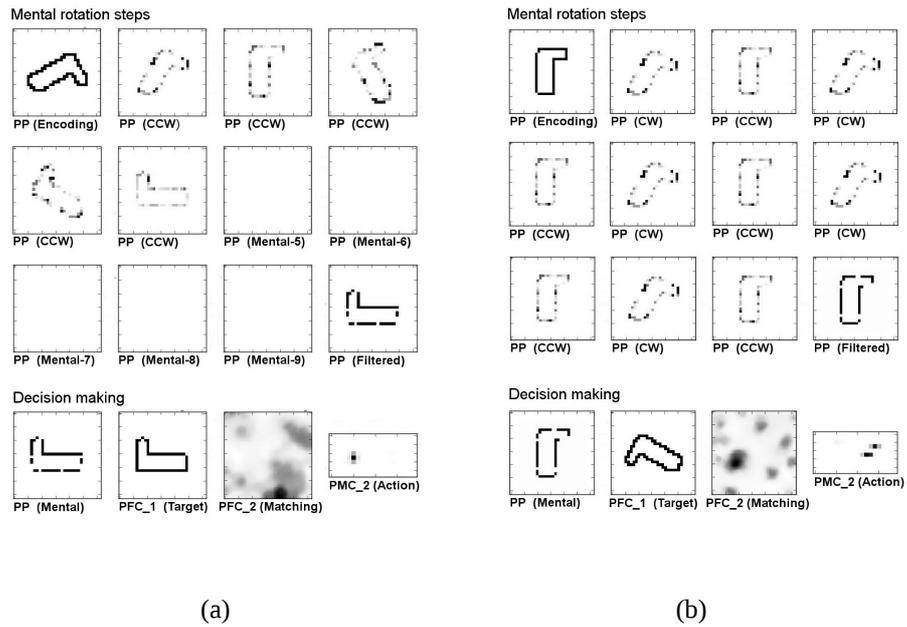

**Figure 5.7** Mental image rotation steps: (a) rotational steps in the case that the model is able to create a sequence of rotated images to reach the target orientation; (b) case in which the model is unable to rotate the seen object. The matching and answering processes are represented by the neural activation of the two bottom-right graphs in both (a) and (b).

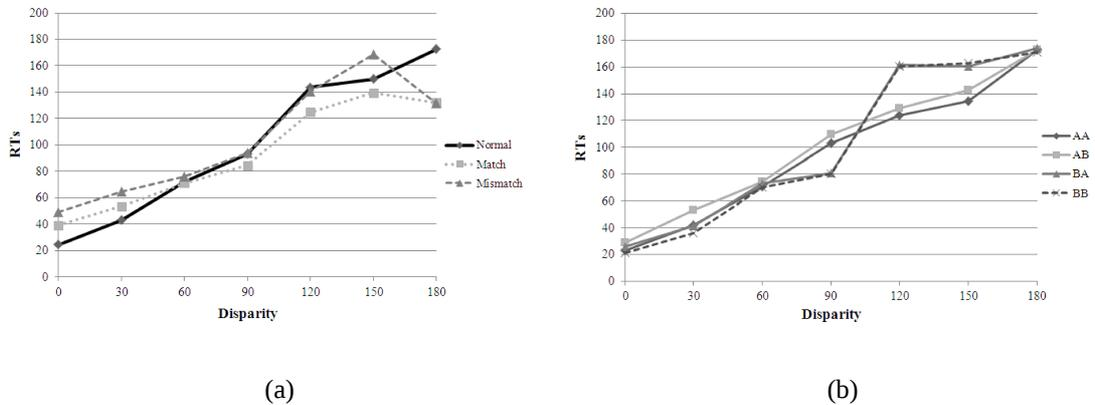

**Figure 5.8** The comparison of response time profiles with different proprioceptive signals. (a) Difference of response time profiles between different pairs of stimuli; AA denotes that the left stimulus is object-A and the target object-A, while AB, BA, and BB denote the other possible combinations. (b) Difference of response times when supplying a matching, mismatching, or no proprioceptive signal (corresponding to the normal operation of the model) to SS.

Although preliminary, the results of the experiment represent an important starting

point to design future extensions of the model directed to fully account for the relations existing between covert and overt mental rotation processes.

### **5.2.3 Discussion**

Various studies support the view presented here for which mental rotation processes rely heavily on sensorimotor brain structures that play an important part in over action. In this respect, however, it is possible that the degree of interaction of the two classes of processes change during development. For example, in studies of mental rotation in human children an interesting finding indicates that the link between motor performance and mental rotation are more pronounced in children than in adults (Funk, Brugger, & Wilkening, 2005; Frick et al., 2009). However, the empirical study by Krüger and Krist (2009) showed opposite findings in which the motor process was less pronounced in the participants aged 5-6 years than in 7 year old children and in adults. The speed of mental rotation also depends on age and improves with development (Kail, Pellegrino, & Carter, 1980). These phenomena might be addressed in future experiments testing the model at different phases of learning or considering other types of learning processes like reinforcement learning (e.g., Barto and Sutton, 1998), applicable in a modelling neurorobotic context as here (Ognibene, Rega, & Baldassarre, 2006; Herbort et al., 2007), that allow overcoming the limitations of associative forms of learning as those used here (Caligiore et al., 2008).

Other important aspects not considered here are related to other types of feedback beside proprioception. In this respect, the visual input of seen hands, not modelled here, plays a central role. Indeed it might be combined with the proprioceptive signal to produce a matching/mismatching effect as the one shown here for proprioception in SS. The role of seen gestures has not been studied in depth yet, so there is no evidence on whether people benefit from such an input when dealing with mental rotation problems.

Some researchers (e.g., Goldin-Meadow, 2005) claim that even blind people produce gestures when they talk. This might suggest the importance of motor processes over perceived image of the hands or objects. In addition, motor processes and visual perception of moving hands might be seen differently in different contexts. In particular, attention mechanisms may lead the subject engaged in the mental rotation task to neglect the seen hands to better focus on the task (Pannebakker et al., 2011). The model might face this problem by sending an additional visual input to PC, an important locus for the integration of proprioceptive and visual information (Hagura et al., 2009).

The model generates errors but in its current version it does not do so in relation to the angular disparity and hence the difficulty of the rotation task is as it happens in human subjects. This limitation might be investigated in future work. For example, at the moment the model can process only two types of objects and this might create mental rotation processes that do not degrade with the number of rotation steps. Endowing the model with the capacity to rotate any type of object might make it more prone to errors when the rotation task becomes more challenging. To permit the rotation of unseen objects, the object orientation detection function might be separated by the object identification one, e.g., using an inferotemporal cortex (IT) map whose neurons encode objects identities independently of their orientation (Goodale & Milner, 1992).

Due to individual differences, people can apply a variety of strategies to solve mental rotation tasks such as: using their own hand to indicate the movements of a stimulus, imagining rotation of the stimulus itself, or even using non-rotational strategies. There is no right or wrong strategy to solve mental rotation tasks. In future work, the integration of some of these abilities and strategies might be incorporated in the model to account for the variety of human performances in solving mental rotation tasks.

# Chapter 6

## Generalisation on mental rotation skills

Despite the model proposed in chapter 5 is able to solve a typical mental rotation task, the model has significant limitations: it lacks mental rotation generalisation capability for novel objects; it generates error rates related to mental rotation tasks that do not reflect the inherent difficulty of the tasks themselves, due to the decision making component of the model being based on a rigid non-biologically plausible mechanism, which leads the model to an abrupt drop in performance when the images to be rotated become increasingly complex; it does not fully exploit the sensorimotor possibilities rendered by its robotic embodied nature (e.g., to investigate the relation between mental rotation and interference/synergy with current proprioception and gestures). These are relevant topics studied in the following literature (e.g., Wexler, Kosslyn, & Berthoz, A., 1998; Wohlschläger & Wohlschläger, 1998). Finally, the model was tested with a simulated robot using the iCub simulator.

This chapter propose a new neurorobotic model of mental rotation that builds upon the prior model (chapter 5) and overcomes its limitations. Specifically the new model has some generalisation capabilities to transfer the mental rotation processes acquired with a small set of 2D visual training stimuli to novel 2D visual objects. Moreover, it employs a flexible decision making mechanism, based on biologically plausible models of decision making (Usher & McClelland, 2001; Bogacz et al., 2006), that reproduces an error rate that varies gradually with the difficulty of the task. Further, its mental rotation capabilities could be challenged with overt movements of the robot, congruent or

incongruent with the covert mental rotation process, to investigate the effects on mental simulation. The model is tested through implementation on the iCub humanoid robot (Sandini, Metta, & Vernon, 2007; Metta et al., 2008). This is relevant not only to facilitate the inclusion in the model of some issues relating to embodied cognition, but also to test the robustness of the model to the variable conditions of the environment and of the robot. For example, in the tests presented, the images from the robot camera changed in different trials due to luminance changes within the environment, the variable response of the camera and the accuracy limitations of the camera motors.

### **6.1 Experiment 3: Mental Rotation and Generalisation Skills**

In this experiment we propose a new model of mental rotation in robots that substantially improves the model proposed in chapter 5 (Seepanomwan et al., 2013a; 2013b) to overcome the limitations presented above. In detail, the model can generalise the mental rotation ability acquired by the training procedure by performing mental rotation and matching on stimuli never seen before. Moreover, in the new model the error rate can be recorded according to the difficulty of the task since the decision making part of the model is based on a flexible stochastic system allowing the model to face increasingly difficult and novel objects while exhibiting abilities that do not degrade abruptly.

The proposed model has been deployed and tested on the real humanoid robot iCub (Metta et al., 2008), instead of its simulator (Tikhanoff et al., 2008). This is an important advance with respect to the previous version of the model. Real world robotic applications, indeed, have to be robust with respect to the variable conditions of the environment, electronics and mechanics of the robot. For example in our case, even with the same configuration of the environment and of the robot setting, the image from

the cameras of the robot slightly changes at two different time steps because of changing light intensity, variable responses of the cameras, and limited accuracy of actuators that affect the position and orientation of the cameras.

### **6.1.1 Methods**

#### *A. The iCub humanoid robot, the stimuli, and the mental rotation task*

##### *The iCub humanoid robot:*

The iCub is used here as a participant of a typical psychological experiment on mental rotation (Shepard & Metzler, 1971; Wexler, Kosslyn, & Berthoz, 1998). It perceives visual stimuli via its eyes (web cameras). The cameras are set to 640x480-RGB mode. iCub is a many degrees of freedom (DoFs) robot and here we use the joint number 5 of the right arm affecting the robot wrist angle. In the mental rotation experiment we devised here the robot does not hold real objects. However, during the acquisition of the mental rotation skills the robot moves its wrist in order to assume the wrist orientation useful to hold the mentally rotated object and read the wrist position through its encoder. Within the model the mental rotation process is affected by the overt action (i.e., the wrist movement and posture), in line with recent evidence about the role of the overt actions on mental rotation processes in humans (Wexler, Kosslyn, & Berthoz, 1998; Wohlschläger, 2001).

##### *Stimuli:*

Figure 6.1 illustrates the three sets of stimuli shown to the robot on a computer screen during the mental rotation. The stimuli are coloured in red to make it easier for their detection by the iCub's camera. They are carefully designed to represent different levels of difficulty in the mental rotation task. Each set (a, b, c) consists of three original objects (the left object in each pair) which can assume four orientations ( $-90^\circ$ ,  $-45^\circ$ ,  $0^\circ$ ,

and 45°) and can have the main of the mirror appearance. Each image shown to the robot is formed by one object shown two times: the right object is the one to be mentally rotated (henceforth “rotated object”) while the left one is the target (henceforth “target object”). Thus, each original object can be used to generate 64 different pairs of stimuli. Stimuli of the set (a) and (b) contain a clear orientation main axis. Stimuli from set (a) are used for training while those from set (b) for testing. Stimuli from set (c) represent a second more difficult test set as they do not have a clear orientational axis.

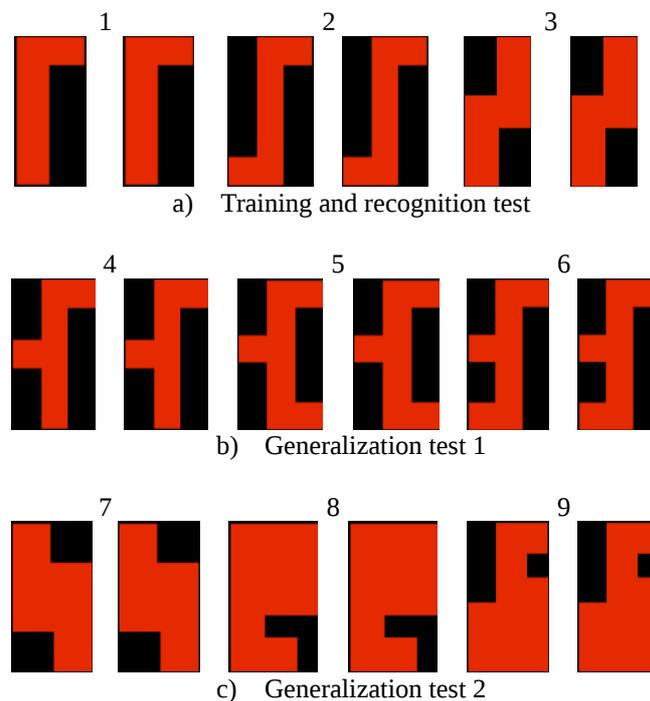

**Figure 6.1** Stimuli used for training and recognition test (a) and for generalization tests (b, c). Each image is formed by one object shown two times, here with a 0° orientation and with main appearance.

*The mental rotation task:*

As in typical mental rotation experiments with humans (e.g., Shepard & Metzler, 1971; Wexler, Kosslyn & Berthoz, 1998) the robot has to compare two visual stimuli that can be different in orientations and appearance (main or mirror), and has to decide if they are the same or different. In this kind of task human participants normally report that in order to make a decision, they mentally rotate one object, clock-wise or counter

clock-wise, until it visually matches or mismatches with the other one (Shepard & Metzler, 1971; Wexler, Kosslyn & Berthoz, 1998). The simulation of this problem solving strategy is the core process of the model. The stimuli are displayed on a computer screen in front of the robot as showed in Figure 6.2 (bottom right).

Once the robot has been trained to acquire the mental rotation ability (see this Sec. on learning), it is tested in three conditions: the recognition test (Recog); the generalization test 1 (Gen-I); and the generalization test 2 (Gen-II). Since in each test the model uses three different objects to create pairs of stimuli, the number of repeats showing the task for each test is  $64 \times 3 = 192$ .

### *B. The model: architecture, functioning and learning*

#### *Model architecture:*

The model consists of several parts, as illustrated in Figure 6.2, corresponding to the main brain areas mainly involved in mental rotation processes (Lamm et al., 2007). These are the primary visual cortex (V1), the parietal cortex (PC), the premotor cortex (PMC), the primary motor cortex (M1), and the prefrontal cortex (PFC). Each area accomplishes several functions and is formed by several subcomponents. In particular: V1 is a  $32 \times 32$  neural map. PC is formed by three distinct areas: the posterior-parietal cortices (PP\_1) and (PP\_2), and the somato-sensory cortex (SS). PP\_1 is formed by three neural maps ( $32 \times 32$ ), PP\_2 by one neural map ( $32 \times 32$ ) and SS by 4 units. The units of PP\_1 and PP\_2 encode, respectively, the current and the next orientation of the rotated object during mental rotation (Rizzolatti & Craighero, 2004), whereas SS units encode the proprioceptive signal related to the robot wrist orientation (Caligiore et al., 2010).

PMC is formed by 2 components: PMC\_1 (four units) and PMC\_2 (one unit). PMC\_1 encode the desired orientation of the wrist to hold the rotated object in a certain

orientation. The orientation of the target object is the final orientation that the rotated object (PP\_1) has to assume through the mental rotation process. The unit of PMC\_2 encodes the answer resulting from the matching process: this leads the robot to use its sound system to say “YES” or “NO” (see below). M1 consists of two areas, M1\_1 (4 x 4 units) and M1\_2 (three units). The units of M1\_1 combine the signals from current (SS) and desired orientation (PMC\_1) to trigger a wrist movement through the units of M1\_2: the selection of n1 causes a 45° clockwise rotation of the wrist; the selection of n3 causes a 45° counter-clockwise rotation; the selection of n2 does not lead to any rotation. Finally, PFC is formed by PFC\_1 and PFC\_2, each formed by one neural map (32 x 32 units). PFC\_1 is a working memory used to store the target object orientation, whereas PFC\_2 is involved in the decision making process (Fuster, 2008). Most of the components of the model are formed by neural maps activated using population code methods (Pouget & Dayan, & Zemel, 2003). The population code theory claims that information (e.g., on stimuli and actions) is encoded in the brain on the basis of the activation of populations of units organized in neural maps having a broad response field. In particular, each unit responds maximally to a certain value of the variables to encode, and then progressively less intensely to values (based on a Gaussian function). Some processes needed to acquire and exhibit mental rotation skills as, for example, supervised learning and action selection, which are possible thanks to the close interaction between the cortical areas shown in Figure 6.2 and subcortical regions not shown in Figure 6.2. This mainly includes the cerebellum and the basal ganglia (Alexander, DeLong, & Strick, 1986; Middleton & Strick, 2000; Caligiore et al., 2012). The model computationally reproduces some of the functions of these cortical-subcortical circuits without explicitly simulating the subcortical areas involved.

### *Model learning:*

The input image is centred on the target or on the rotated object separately, and a red colour filter is applied. The edges of each object are extracted with the Canny edge detection technique (Canny, 1986), using the OpenCV library. The output from the edge detection process is used to activate the input units of V1. The rotated image goes to the three maps of PP\_1 whose units encode the current stimulus (shape and orientation of the rotated object). In particular, only one of the three maps of PP\_1 is activated according to the planned wrist movement supplied by M1\_2 (see below). If PP\_11 is chosen the image has to be rotated clockwise by PP\_2, if PP\_12 is chosen the image has to be rotated counter-clockwise by PP\_2, whereas if PP\_13 causes no rotation in PP\_2. This way of integrating visual and proprioceptive information agrees with the computational hypothesis on how the parietal regions implement the spatial transformation based on gain neural fields (Pouget & Sejnowski, 1997; Caligiore et al., 2008).

Except for the initial step of the mental rotation process, when the units of PP\_2 encode the rotated object as PP\_1, during mental rotation the units of PP\_2 encode the predicted orientation of the rotated object. At the beginning of the rotation PP\_2 causes the activation of units within SS. This activation pattern encodes the wrist orientation that the robot would assume to hold the object represented in PP\_2 as each of the four SS units encodes one of the four possible orientations of the objects.

The edge information on target object is sent to PFC\_1. The target object is used as the goal of the mental rotation. PFC\_1 supplies a signal to PMC\_1 through the connection C1 causing a pattern of activation in PMC\_1. This pattern represents the desired posture that the robot has to (mentally) reach to make a mental rotation useful to overlap the image within PP\_2 with the target image within PFC\_1.

The signal from SS is combined with the signal from PMC<sub>1</sub> to activate M1<sub>1</sub>. This encodes a combination of wrist posture useful to hold the current object (from SS) and the desired wrist orientation to hold the target object (from PMC<sub>1</sub>) to select a wrist rotation by M1<sub>2</sub>. In particular, M1<sub>1</sub> integrates information from SS and PMC<sub>1</sub> by signal multiplication: each unit in PMC<sub>1</sub> connects to all units in a particular row of M1<sub>1</sub>, while each unit in SS does the same to a particular column of the 16 units in M1<sub>1</sub>, the four diagonal central units are connected to n<sub>2</sub>, six units at the top right area are connected to n<sub>3</sub>, and six units in the bottom left area are connected to n<sub>1</sub>. The process of action selection described here abstracts the action selection mechanisms involving motor cortex-basal ganglia loops (Alexander, Delong, & Strick, 1986). As units in SS and PMC<sub>1</sub> are activated by Gaussian functions, the M1<sub>1</sub> has a 2-dimensional Gaussian activation calculated as follows:

$$m1_{1k} = pmc_{1i} * ss_j \quad (6.1)$$

M1<sub>2</sub> units activate as follows:

$$n_i = G(\|\overline{M1_1} - \overline{w}_i\|) \quad (6.2)$$

where  $n_i$  denotes the activity level of output unit  $i$  in M1<sub>2</sub>,  $G$  is a Gaussian transfer function,  $M1_1$  refers to a vector of neural activity in M1<sub>1</sub>, and  $w_i$  is a vector of connecting weight between units in M1<sub>1</sub> and a particular unit ( $n_i$ ) in M1<sub>2</sub>. The following equation is used to calculate the probability value that a unit in  $n_i$  M1<sub>2</sub> is selected (softmax function (Whiteson, Taylor, & Stone, 2007)):

$$P(n_i) = \exp\left(\frac{n_i}{\tau}\right) / \sum_{i=1}^3 \exp\left(\frac{n_i}{\tau}\right) \quad (6.3)$$

where  $P$  is a probability function that gets activation of unit  $n_i$  as input and generates a probability value according to the activity level of all units in M1<sub>2</sub>,  $\tau$  is the temperature parameter, set to 0.3, which regulates the sharpness of the selection.

The signal from M1<sub>2</sub> is used as input for PP<sub>1</sub> to select the suitable direction of

the mental rotation through the selection of PP\_11, PP\_12, or PP\_13 within PP\_1. The activation of the units of the selected map in PP\_1 causes a rotated image in PP\_2. The feedback connection PP\_2-PP-1 is used to update the input of PP\_1 after each rotation step, in order to have a rotated image in one of the three maps of PP\_1 (see Baldassarre (2003)). Forward and bidirectional planning based on reinforcement learning and neural networks in a simulated robot (Butz, Sigaud, & Gérard, 2003; Ziemke, Jirnhed, & Hesslow, 2005; Grush, 2004). PP\_1 and PP\_2 work as a forward model with a feedback connection from the predicted state (PP\_2) to the current state (PP\_1) allowing a sequence of mental rotations ending when the matching process is triggered.

The rotated image in PP\_2 causes the activation of a new pattern in SS encoding the wrist orientation corresponding to the object in PP\_2. When the most activated units in SS and in PMC\_1 coincide, the central 0° rotation unit of M1\_2 is strongly activated and the mental rotation process terminates and the robot can give an answer. PMC\_2's unit encodes the result of the matching process, that is the type of vocal signal the robot produces to say "YES" or "NO" to indicate if the two objects are same or different. PFC\_1 is connected to PFC\_2 by one-to-one positive connections set to +1 (C7), whereas PP\_2 is connected to PFC\_2 by one-to-one set to -1 (C8). Thus, the units of PFC\_2 encode the difference between the signals supplied by PFC\_1 and PP\_2. Same images have no or a little un-overlapped units, while different images have a large number of non-overlapped units so PFC\_2 has a higher activation. PFC\_2 activates PMC\_2 through the connection C9. If the activity of PMC\_2 unit exceeds a threshold (5% of all active units in PFC\_1) this indicates that the two objects are different and the robot gives as answer "NO" otherwise "YES". The maximum number of rotation cycles is set to 15. If the number of rotation cycles achieves this number the model could not perform the mental image rotation on time, so the answer is considered to be "NO".

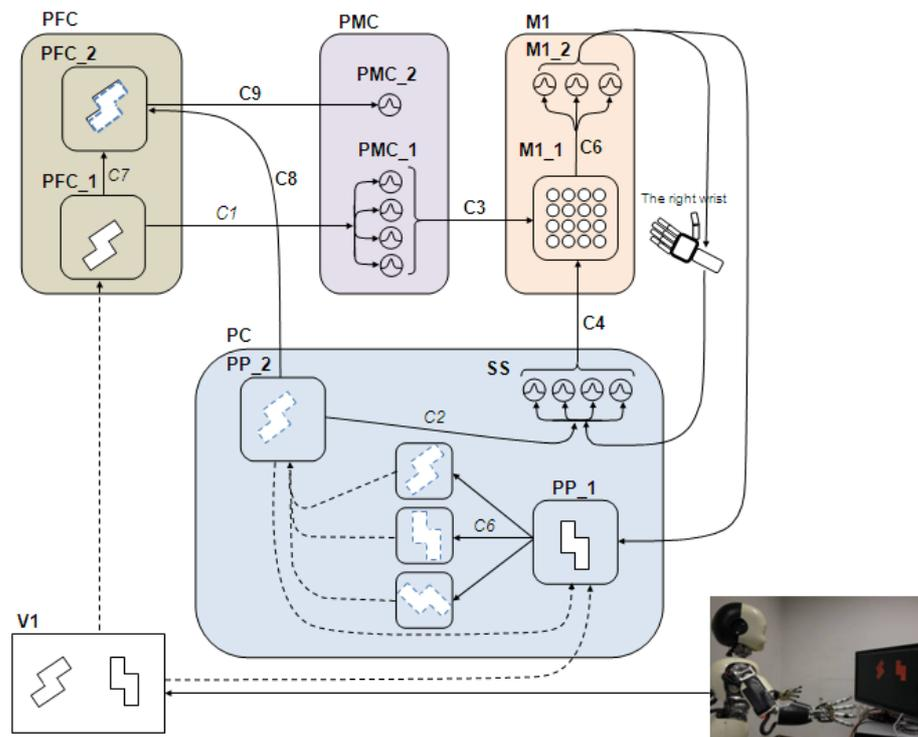

**Figure 6.2** The neural network model for mental rotation. Each box represents the model components. The arrows represent information flows from one component to another. The arrows with the letter “C” are the connections trained during the learning phase while those with a letter “C” are hardwired.

*Model learning:*

We assume that the system uses three random points, as an abstraction of the salient features of the complete images seen in life, to train C6. In this way, the learning procedure of the forward model is easier and faster. Figure 6.3 and Figure 6.4 illustrate the training. Filled dots represent an image encoded in PP\_1 whereas empty dots represent the desired image that PP\_2 units should encode after the rotation. This latter image is obtained by using “cvWarpAffine” the image transformation function of the OpenCV library.

In Figure 6.3, the left panel illustrates the creation of a 45° clock-wise rotation image related to three dots, while the right one shows the opposite pattern of rotation. Arrows, solid lines, and dashed lines in both panels are used to illustrate the direction of

rotation. Small red circles are the centre of rotation. The placing of the three random dots within the area of dashed square (23x23) was done to prevent the cases that the rotated dots fall outside the large square (32x32).

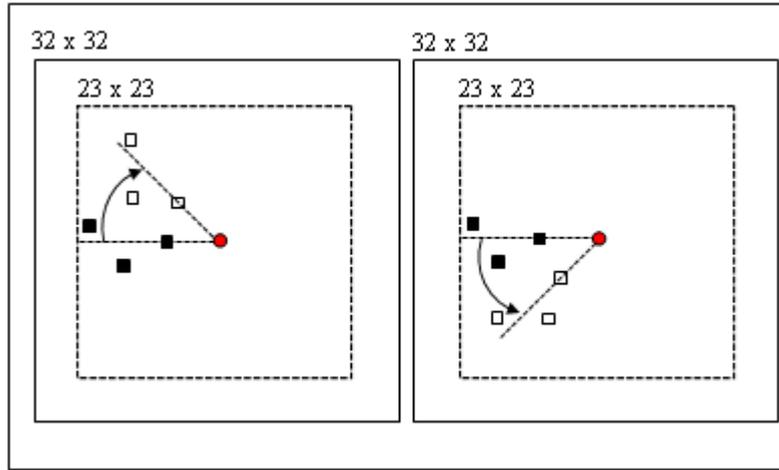
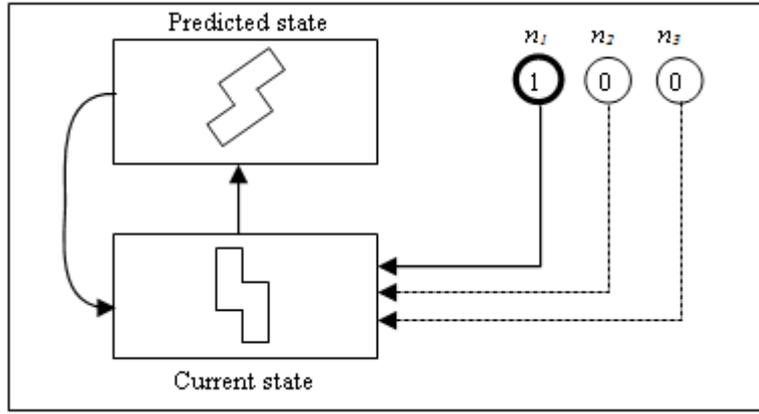

**Figure 6.3** Patterns generation for the forward model learning

The three random dots encoded by PP\_1 are considered the input pattern of the forward model (i.e., current state in Figure 6.4) while the predicted dots encoded by the units of PP\_2 are the output (i.e, predicted state in Figure 6.4). Only one of the three maps of PP\_1 is activated according to the wrist orientation decided by M1\_2. One unit within M1\_2 is randomly selected and the selected wrist rotation is used to choose the corresponding map of PP\_1, which is activated with the abstract dots image. The training of the forward model consists of creating an association between the current image encoded by one of the PP\_1 maps, and the next desired image encoded in PP\_2 (connection C6) based on a simple delta rule:

$$\Delta w_{ij} = \eta (y_i - a_{ij}) x_j \quad (6.4)$$

where  $\Delta w_{ij}$  is the weights change of the connection between unit  $i$  and  $j$ ,  $x_j$  is the activation potential of input unit  $j$ ,  $y_i$  is the activation potential of output unit  $i$ ,  $a_{ij}$  is actual output between unit  $i$  and  $j$ ,  $\eta$  is the learning rate which is set to 0.1.



**Figure 6.4** Forward model learning

The acquisition of the forward model for mental rotation might pivot on the supervised learning processes implemented by the cerebellum (Doya, 2000) and in particular in this case, by the parieto-cerebellar and motor-cerebellar cortical loops (Middleton & Strick, 2000; Caligiore et al., 2012). Note that, the predicted image in PP\_2 will be degraded over a number of rotations.

We now focus on the training of C2 (the training of C3 is done in the same way) which mimics a sort of motor babbling process used by infants to acquire motor skills (see Caligiore et al., (2008)). We assume that the robot holds an object and this is represented in PP\_1 and PP\_2. This means that in SS the unit corresponding to the wrist orientation that the robot would feel to hold the object in PP\_2 is activated. The units of SS and PMC\_1 have the Gaussian activation:

$$ss_i = G(\|\overline{PP} - \overline{w}_i\|) \quad (6.5)$$

$$pmc_{1i} = G(\|\overline{PFC}_1 - \overline{w}_i\|) \quad (6.6)$$

where  $ss_i$  and  $pmc_{1i}$  are activity level of output unit  $i$  in the map SS and PMC\_1 respectively,  $G$  refers to a Gaussian transfer function,  $PP$  is a vector of neural activity in PP,  $PFC_1$  is a vector of neural activity in PFC\_1, and  $w_i$  is a vector of connection weights between two neural maps. A Kohonen learning rule (Eq. 6.7) is used to train the

connections C2 by artificially selecting as the winning unit in SS the unit encoding the wrist posture:

$$\Delta w_i = \eta(x_i - w_i); w_i = w_i + \Delta w_i \quad (6.7)$$

$$w_i = w_i / \sum_{i=1}^n w_i \quad (6.8)$$

where  $\Delta w_i$  denotes the weights change of unit  $i$ ,  $x_i$  denotes activation potential of unit  $i$ ,  $\eta$  denotes the learning rate which is set to 0.1, and  $w_i$  is a current weight value. This process is repeated for all the possible orientations that the objects of the training set can assume.

### 6.1.2 Results

The results reported in this section are obtained testing the model 10 times and averaging the results. Each time all connection weights are reassigned with different random values. Two types of information are recorded during the experiment: the response time (RT), which is the number of mental image rotation steps, and the error rates (ERs) of the “YES”-“NO” answers.

The graph of Figure 6.5a shows RTs profiles from the three tests: Recog, Gen-I, and Gen-II. The result shows how the orientation disparity between the target and rotated objects directly affects RT. In particular, the increase of the disparity causes a higher number of repeated mental rotation steps to give an answer. This is in agreement with the result from experimental psychology that often found RT linearly increasing with the stimuli disparity (Shepard & Metzler, 1971). More in particular, the RTs of Recog and Gen-I follow a similar trend while Gen-II is quite different. In this case the RT is lower and it does not increase if the disparity is greater than 90°. Moreover, when the disparity is equal to 0°, Recog and Gen-I do not cause any rotation whereas Gen-II performs one rotation step on average.

Figure 6.5b shows that the ERs for Recog is 18.70%, while it is equal to 24.70% and to 54.30% for Gen-I and Gen-II respectively. When considered for each particular disparity, as indicated in Figure 6.5c, ERs profiles at 135° disparity of Recog and Gen-I drop significantly. The error rate of Gen-II at 0° is the same level as Recog and Gen-I, but increases drastically for a disparity of 45° and remains at that level for a disparity of 90° and 135°.

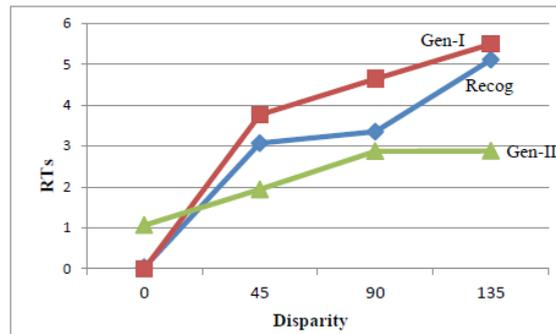

a) Response time profiles

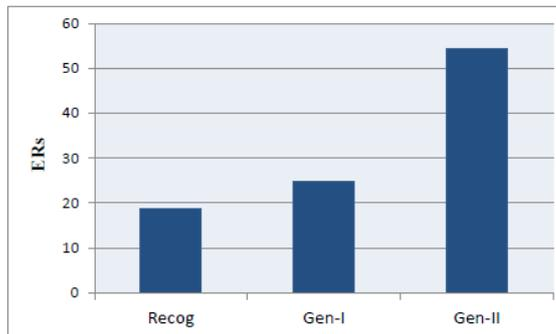

b) Overall error rates

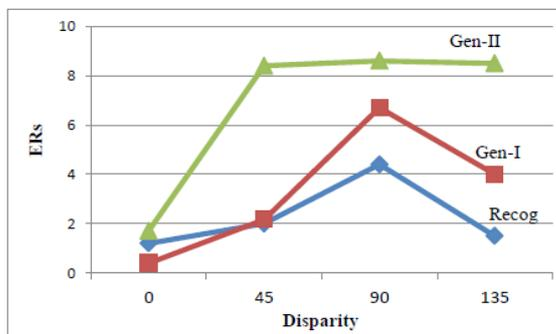

c) Error rate profiles

**Figure 6.5** Experimental results

### 6.1.3 Discussion

The results show how the model is able to generalize mental rotation skills to novel, never seen objects. This is a remarkable result with respect to the previous version of the model (Seepanomwan et al., 2013a; 2013b) and is an important achievement to make the robot able to work autonomously in changing environments. The forward model circuits implemented by the parietal areas of the model are the core elements to get this generalization skill. Moreover, the performance of the model during the mental rotation task now exhibits a graceful degradation of performance to the increasing difficulty of the task with respect to the previous version of the model. This implies that the model is more accurate at performing the mental rotation task. The affordances processing and the stochastic softmax action selection system implemented within the premotor and motor areas of the model are the key elements allowing us to get this improvement. For example, for the Gen-I test, where the stimuli are unseen and consist of many details, the model is able to rotate and compare the two objects in a good way achieving some levels of generalization with an acceptable error rate. However, the performance in this case is less good with respect to the Recog condition. This is because the current orientation pattern (SS) and the desired orientation pattern (PMC\_1) are less known, as the robot sees the objects for the first time. Thus, M1\_1 and M1\_2 have a greater uncertainty and the robot makes more errors. This process is even more evident for the Gen-II test and indeed the error rate is greater. In this case the objects do not activate a clear orientation pattern in SS and PMC\_1, so causing a great degree of uncertainty within the stochastic process which decides the wrist rotation in M1\_2.

RT in the Gen-II test is the smallest because the stimuli of Gen-II cause a similar activation of the units of PMC\_1 and SS as the objects do not have a clear orientation. As a consequence, M1\_1 tends to always activate the central units. M1\_2 will tend to

select the “no rotation” unit  $n_2$  and the mental rotation will be stopped quickly. Similarly, the ERs of Gen-II is the highest indicating that it interprets most of testing stimuli incorrectly. In detail, it often answers “YES” instead of “NO” in cases when the two stimuli are different because the square like shape of the objects decreases the differences between the target and rotated objects.

The low ERs at  $135^\circ$  for Recog and Gen-I tests depend on the image reproduction and matching processes. When the model decides to rotate the object, the new image in PP\_2 is slightly changed. This does not affect the overall shape of the object but the details are removed. This benefits the case of stimuli that have major different parts, in particular those of the Recog and Gen-I (see Figure 6.1). By contrast, stimuli that contain no major differences, as in Gen-II, are judged the same in most cases.

## **6.2 Experiment 4: Generalisation, Decision Making and Embodiment**

### **Effects in Mental Rotation**

This experiment, in addition to the tasks studied in previous model (chapter 5), we employ a flexible decision making mechanism, based on biologically plausible models of decision making (Usher & McClelland, 2001; Bogacz et al., 2006), that reproduces an error rate that varies gradually with the difficulty of the task. Further, its mental rotation capabilities are challenged with overt movements of the robot that are congruent or incongruent with its covert mental rotation process to investigate the effects of mental simulation.

Several components of the model are formed by neural maps using, in specific or abstract ways, population codes. Neural maps are suitable to model cortical areas as they capture their important 2D topological organisation and also facilitate the analysis

and visualisation of the processes happening within them (Caligiore et al., 2014). Population codes (Pouget, Dayan, & Zemel, 2003) are based on the idea that information (e.g., on stimuli and actions) is encoded in the brain on the basis of the activation of populations of units organized in neural maps having a broad response field. In particular, each unit responds maximally to a certain value of the variables to encode and then progressively less intensely to more distant values. This response can be obtained with short-lateral excitatory connections and long-lateral inhibitory connections, or in a more abstract fashion (as for most maps) with Gaussian functions.

To implement the decision making process involved in the mental rotation task the model uses a mutual inhibition model (Usher & McClelland, 2001; Bogacz et al., 2006). In this model, closely related to the architecture and neural competition that can be implemented by population-code maps, different decision options are represented by neural units that accumulate in time the evidence (support) on the goodness of the different options, compete through reciprocal inhibitory connections of the units, and finally produce a decision when the activation of one of them reaches a given threshold. This model (together with other analogous models; Bogacz et al., 2006) is very important as it allows the reproduction of the reaction times often recorded in psychological experiments (Erlhagen & Schöner, 2002; Caligiore et al., 2010; Caligiore et al., 2008) and at the same time is one of the most accredited models of decision making processes taking place in the brain (Bogacz, 2007).

In the brain, several processes needed to acquire and express mental rotation (e.g., learning from experience, and selection of cortical contents) are putatively implemented by cortical areas working in close cooperation with sub-cortical regions, in particular basal ganglia and the cerebellum with whom they form whole integrated systems (Alexander, DeLong, & Strick, 1986; Middleton & Strick, 2000; Caligiore et al., 2013;

Baldassarre, Caligiore, & Mannella, 2013). For simplicity, the model reproduces in abstract ways such processes, e.g., to implement the decision making processes and the mapping of the object representations to the corresponding arm postures, without explicitly simulating these sub-cortical regions.

### **6.2.1 Methods**

#### *Simulated participants*

The iCub humanoid robot was used to simulate the behaviour of the participants of the mental rotation experiment (see more details in chapter 4).

#### *The stimuli*

Figure 6.6 shows the three sets of 2D abstract objects, broadly similar to those employed by Hochberg & Gellman (1977), used as stimuli during the mental rotation tasks. The stimuli were colored in red to make easier their detection by the iCub's camera. They were designed to create different levels of difficulty in the mental rotation task. Each set (A, B, C) consisted of three objects which could assume six orientations ( $90^\circ$ ,  $60^\circ$ ,  $30^\circ$ ,  $0^\circ$ ,  $-30^\circ$ ,  $-60^\circ$ ) and could have a “basic” appearance (the one shown in the figure) or an appearance corresponding to the “mirror” image of the basic appearance. The stimuli of the set A and B, three for each set, contained a clear orientation main axis (we will see this is important to perform mental rotation). However, the stimuli of set B were formed by more features than the stimuli of set A. Stimuli from set A were used for training the model and for a recognition test (Recog; Figure 6.6a) whereas those from set B were used in a test directed to measure the generalisation capabilities of the model (Gen1; Figure 6.6b). Stimuli from set C represented a second more difficult data set as they did not have as strong orientation axis as the previous two sets. This set was therefore used for a second, more challenging

generalization test (Gen2; Figure 6.6c). Figure 6.6d gives some examples of pairs of stimuli shown to the robot during the tests Recog, Gen1 or Gen2 (each test involved showing multiple pairs in different trials). In each object-pair image the object on the left was the target object (henceforth called “target object”) and the object on the right was the one to be mentally rotated (henceforth “rotated object”). Each object was used to generate 144 object-pair images ( $144 = 22 \times 6 \times 6$ , here 22 is the number of the possible combinations of the basic and mirror appearance of the target and the rotated objects, and 6 is the initial possible orientations of the target and the rotated objects). The number of object-pair images used in each test was therefore 432 ( $144 \times 3$ , where 3 is the number of objects for each set), and the one used in the three tests was 1296 ( $432 \times 3$ ).

The training of the model's basic ability to rotate objects, putatively acquired by the real experiment participants before undergoing the experiment tests, was done on the basis of images each formed by 3 dot-points randomly located in the image. This was done because preliminary experiments showed that training the robot with standard objects (e.g., as those used to during tests) was computationally very demanding and progressively converged to abilities as those acquired by the robot with the three-dot simpler images.

1	2	3
(a) Objects used for learning and for the recognition test (Recog)		
4	5	6
(b) Objects used for the generalization test 1 (Gen1)		
7	8	9
(c) Objects used for the generalization test 2 (Gen2)		
Recog	Gen1	Get2
(d) Sample pairs of stimuli		

**Figure 6.6** (a) Stimulus set A used for training and for the recognition test (Recog). (b, c) Stimulus sets used for the generalization tests (respectively Ge1 and Gen3). (d) Three object-pair images used during the tests. In the three examples, the left object is the target object, here rotated 90° to the left, whereas the right object is the object to be rotated, here having a 0° rotation (in all three examples the rotated object is different from the target object).

### *The mental rotation task*

The robot was involved in a mental rotation task similar to those typically used in mental rotation experiments with humans (e.g., Shepard & Metzler, 1971; Wexler, Kosslyn, & Berthoz, 1998). In the task, two visual stimuli having different orientation (90°, 60°, 30°, 0°, -30°, -60°) and appearance (“basic” or “mirror”) combinations, are shown to the robot on a computer screen as illustrated in Figure 6.7 (bottom right). The

robot has to compare the two stimuli and decide if they are the same or different. The model does not have attention control, so the behaviour of scanning the target and the rotated objects with the camera is hardwired and performed in sequence.

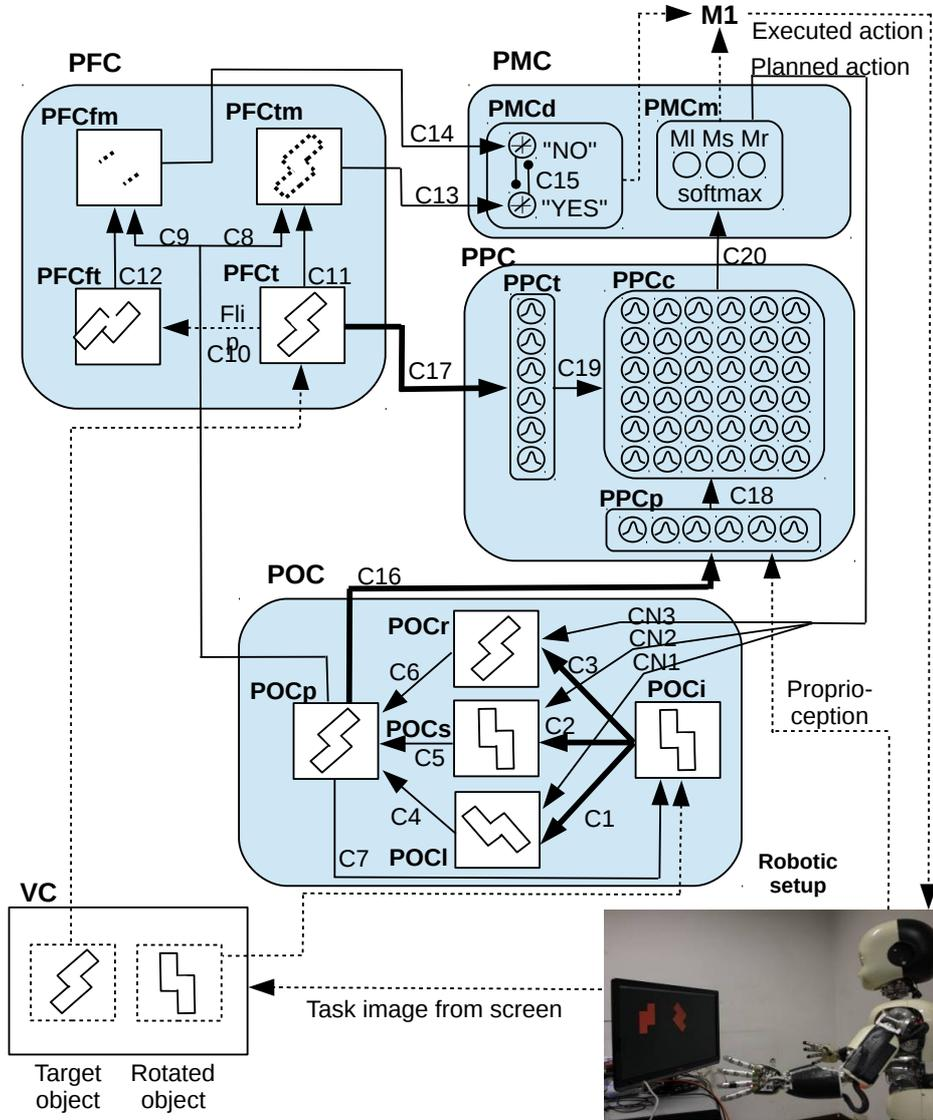

**Figure 6.7** The neural network model controlling the robot in the mental rotation task. The bottom right picture shows the robot in front of the screen where it sees the target and the rotated objects. Thin arrows indicate hardwired connections (fixed connection in most cases are set to 1).

*Model architecture and functioning of its components*

The model architecture (Figure 6.7) is formed by several components corresponding to the main brain areas involved in the mental rotation processes. The components of the

model architecture are the early visual cortical areas (VC), the parieto-occipital cortex (POC), the posterior-parietal cortex (PPC), the premotor cortex (PMC), the prefrontal cortex (PFC) and the primary motor cortex (M1). Each component is formed by subcomponents performing different functions. VC is an image-processing component that extracts the edges of objects from the current image in a way which is reminiscent of early visual cortex processes (Hubel, 1988). POC is formed by five neural maps of 32 x 32 units each: POC<sub>i</sub> encodes the current imaged orientation of the rotated object during mental rotation; POC<sub>l</sub>, POC<sub>s</sub> and POC<sub>r</sub> anticipate the image of the rotated object if a left/still/right mental rotation of respectively -30°, 0°, 30° of the current image encoded in POC<sub>i</sub> is performed. Based on the planned movement supplied by PMC<sub>m</sub>, only one of these three possible rotations is performed (for example, leading to the rotated object image, encoded in POC<sub>r</sub>). The selected image is relayed to POC<sub>p</sub> that encodes the predicted rotated image depending on the performed rotation.

PPC is formed by three components. PPC<sub>p</sub> is formed by six units and encodes the proprioceptive signal related to the robot wrist orientation corresponding to the current actual or imaged orientation of the mentally rotated object encoded in POC<sub>p</sub>. PPC<sub>t</sub> is formed by six units and encodes the target orientation of the wrist corresponding to the orientation of the target object encoded in PFC<sub>t</sub>. PPC<sub>c</sub> (6 x 6 units) combines the signals from the current imaged wrist orientation (PPC<sub>p</sub>) and its desired orientation (PPC<sub>t</sub>) to select a desired movement in PMC<sub>m</sub>.

PMC is formed by two components. PMC<sub>m</sub> is formed by three units that encode three possible movements (taking place in M1, here not explicitly simulated), i.e., respectively: M<sub>l</sub> = -30° anti-clockwise “left” rotation of the wrist; M<sub>s</sub> = 0° “stay” rotation; M<sub>r</sub> = 30° clockwise “right” rotation. PMC<sub>d</sub> is explained below as dependent on PFC.

PFC is formed by four neural maps of 32 x 32 units each. PFCt and PFCft are working memory maps used to store information about the target object having respectively its visual appearance or an appearance corresponding to the target image flipped along the main object axis of the object. PFCtm and PFCfm compute the amount of overlap (matching) between the rotated object image and respectively the basic and the flipped target object to support the decision making process implemented in PMCd.

Finally, PMCd is formed by two units activated by “evidence” from PFC on the current matching (overlap) of the predicted rotated image (POCp) with respectively the target object (PFCt; the overlap of the two images is encoded in PFCtm) or with its flipped image (PFCft; the overlap is encoded in PFCfm). On this basis, PMCd implements a decision making process (neural competition) selecting a “YES” or “NO” response mimicking the decision to press one of the two response buttons of the experiments with humans (below we give further details on this). Table 6.1 illustrates the main features of the neural maps used in the model whereas Table 6.2 summarizes the main features and functions of the connections between them.

**Table 6.1** Key features of the neural maps of the model

<b>Map</b>	<b>Area</b>	<b>Encoding</b>	<b>Number of neurons</b>
POCi	POC	Current object mental image	32 x 32
POCl, POCs, POCr	POC	Possible rotated object image	32 x 32
POCp	POC	Predicted object image	32 x 32
PFCt	PFC	Target object image	32 x 32
PFCft	PFC	Flipped target object image	32 x 32
PFCtm	PFC	Target/object match	32 x 32
PFCfm	PFC	Flipped target/object match	32 x 32
PPCp	PPC	Proprioception of wrist	6
PPCt	PPC	Target wrist orientation	6
PPCc	PPC	Target-actual orientation combination	6 x 6
PM Cm	PMC	Planned wrist movement	3
PM Cd	PMC	Decision “YES/NO”	2

**Table 6.2** Key features of the connections of the model

Connection	Type	Weights values	Function	Areas
C1, C2, C3	All-to-all	Trained with delta rule	Mental image rotation	POC
C4, C5, C6, C7	One-to-one	1.0	Relays of information	POC
C8, C9	One-to-one	-1.0	Mental image for matching	POC → PFC
C10	Hardwired	Flipping transformation	Target object flipping	PFC
C11, C12	One-to-one	1.0	Image orientation for matching	PFC
C13, C14	All-to-all	1.0	Info in support of "YES/NO"	PFC → PMC
C15	One-to-one	-0.5	Dynamic competition	PMC
C16	All-to-all	Trained with Kohonen	Orientation → proprioception	POC → PPC
C17	All-to-all	Trained with Kohonen	Target → desired wrist angle	PFC → PPC
C18	All-to-all	{0.0, 1.0}	Info on predicted angle	PPC
C19	All-to-all	{0.0, 1.0}	Info on desired angle	PPC
C20	All-to-all	{0.0, 1.0}	Action selection	POC → PMC
CN1, CN2, CN3	All-to-all	1.0	Selection of rotation	PMC → POC

*Model overall functioning:*

Each trial of the robot test is divided in succeeding time steps. At each step the robot performs a mental rotation. At each step, the robot perceives the image of the target object and of the rotated object in the computer screen via its left eye (camera). To this purpose, the eye gaze (centre of the camera) is first focused on the target object and then on the rotated object with a hardwired movement. The two images are red-colour filtered and the edges of each object are extracted with the Canny edge detection technique (Canny, 1986; OpenCV library). The output from the edge detection process is used to activate the input units of VC. The target-object image activates the PFCt map, that stores the target image as a working memory and this activates PPCt, encoding the current target (i.e., desired) wrist orientation corresponding to the current target object orientation.

Within POC, in the first mental rotation step POC<sub>i</sub> activates POCs, corresponding to an anticipated image after a planned rotation of 0° (i.e., no rotation/still object). From the second mental rotation onward, POC<sub>i</sub> activates one of the POC<sub>l</sub>, POCs, POC<sub>r</sub> maps

depending on the planned movement (PMCP) and corresponding to a possible wrist rotation of +30°, 0°, -30° respectively.

The activation of PFCt is used as the goal image of the mental rotation. To this purpose, PFCt activates PPCt through connection C17 causing a pattern of activation within it representing the desired posture of the wrist, corresponding to the target object orientation. Within PPC, PMCc combines the signal from PPCp, encoding the wrist posture corresponding to the current orientation of the rotated object, with the signal from PPCt, encoding the target (desired) wrist orientation, to suitably select a movement within PMCM. This integration is done with a signal multiplication similar to what happens in parietal cortex (Pouget & Sejnowski 1997; Pouget, Dayan, & Zemel 2003). In particular, each unit in PPCt is connected to all units in the corresponding unit row of PPCc, whereas each unit in PPCp is connected to all units of the corresponding unit column in PPCc: the activation of a PPCc unit is obtained by multiplying the activation of the two input signals (see Figure 6.7; all the connections of C18 and C19 are equal to 1 when present; see Salinas & Abbott, 1996, for a neural-network implementation using only standard additive neural operations to obtain gain-field effects as those obtainable with multiplication). In more detail, PPCp and in PPCt are one-dimensional population codes encoding the object orientation in terms of wrist posture. PPCc is a two dimensional map encoding, with a population code, the combination of information from PPCp and PPCt as follows:

$$PPCc_{ji} = PPCt_j * PPCp_i \quad (6.9)$$

PMCM units receive the following activation from PPCc:

$$AM_k = \sum_{ji} (w_{kji} * PPCc_{ji}) \quad (6.10)$$

where  $AM_k$  is the activity of units Ml, Ms, Mr of PMCM and  $w_{ji}$  are the connection weights from PPCc to PMCM. The connection weight  $w_{ji}$  have a particular

configuration: the 6 main-diagonal units of PPCc are equal to one only towards unit Ms in PMCM and zero otherwise. The 15 units at the top right of the main-diagonal are equal to one only towards unit Mr and zero otherwise, and the 15 units at the bottom left are equal to one only towards unit Ml and zero otherwise. PMCM units are activated on the basis of a softmax function ensuring an output that sums up to one for the three units and hence can be interpreted as a probability used to randomly select one of the three corresponding actions (Ml, Ms, Mr):

$$p(M_k) = \exp(AM_k / \tau) / \sum_q \exp(AM_q / \tau) \quad (6.11)$$

where  $p(M_k)$  is the probability of selecting action  $M_k$ ,  $\exp(.)$  is the exponential function, and  $\tau$  is the temperature parameter of the softmax function (set to 0.1) that regulates the sharpness of the selection. The stochastic process of action selection used here abstracts the winner-take-all action selection mechanisms possibly implemented in basal ganglia-motor cortex loops (Alexander, DeLong, & Strick, 1986; Baldassarre, Caligiore, & Mannella, 2013) used in most models of these loops (Doya, 2000).

The signal from PMCM is used as input to POC to select the suitable direction of the mental rotation through the selection of either POCi, POCs, or POCr predictions. Therefore, the units of these maps activate only if they receive an input from the corresponding units of both PMCM and POCi. This is neurally implemented with a summation of the two signals and a threshold of 1.5. The selection of the activation pattern of one of these maps causes the prediction of a rotated image in POCp. In the next rotation step, the rotated image in POCp is fed back to POCi and to PPC (and hence PMC) to cause the next mental rotation, thus implementing a repeated reverberation of information through POC-PPC-PMC implementing the visual and motor mental rotation processes. Reverberation mechanisms similar to these and pivoting on forward models (here implemented by the POCi-POCl/s/r neural networks)

have been extensively used in the past as a proxy to represent planning based on mental imaging in bioinspired computational models (Baldassarre, 2003; Butz, Sigaud, & Gérard, 2003; Ziemke, Jirnhed, & Hesslow, 2005; Grush, 2004).

We now focus again on PMC and in particular to the decision making process implemented in PFC/PMCd. This process allows the model to decide if any internally generated images of the rotated object which match the target object image or its flipped image. To this purpose, PFCt and PFCft act as a working memory storing respectively the target object image from VC and its flipped image (the latter is obtained through the hardwired abstract connections C10). PFCtm is formed by units that activate only when the units of the mentally-rotated object image in POCp match the units of the target object image encoded in PFCt. To this purpose, PFCt and POCp are connected to PFCtm through one-to-one connections with weights set to one (C11 and C8 respectively) and PFCtm units activate with one only when their input overcomes a threshold of 1.5 and with zero otherwise. Similarly, based on connections C9 and C12, PFCft computes the overlap between the rotated object image encoded in POCp and the flipped target image encoded PFCft.

The units of PFCtm are all connected to the unit of PMCd representing a YES reply action (PMCDyes). Similarly, the units of PFCfm are all connected to the unit of PMCd representing a NO reply action (PMCDno). The units of PMCd, forming a reciprocal inhibition model of decision making, implement a neural dynamic competition as follows (Usher & McClelland, 2001; Bogacz et al., 2006):

$$PMCD_{yes} = -k PMCD_{yes} - w PMCD_{no} + PFC_{tm} \quad (6.12)$$

$$PMCD_{no} = -k PMCD_{no} - w PMCD_{yes} + PFC_{fm} \quad (6.13)$$

where  $k$  is a decay rate of PMCd units ( $PMCD_{yes}$ ,  $PMCD_{no}$ ) and  $w$  is the inhibitory connection between the two PMCd units. For each mental rotation step, this dynamic

competition makes ten cycles that allow the units of PMCd to accumulate evidence for the YES or NO reply and to compete between them. When one of the two units achieves the threshold of 1.2, the system is considered to have made a decision in favour of the YES/NO reply corresponding to it. The time needed to solve this competition, measured from the beginning of the mental rotation trial, is considered as the reaction time taken by the system to perform the mental rotation and to make a decision (cf. Usher & McClelland, 2001; Bogacz et al., 2006; Erlhagen & Schöner, 2002; Caligiore et al., 2010; Caligiore et al., 2008). The maximum number of mental image rotation steps for a trial was set to 20 in the simulations: if the model did not give an answer within this time window it was forced to give a random answer (but this happened rarely). Importantly, the accumulation of evidence lasted during the whole trial, i.e., the units of PMCd were reset at the beginning of each trial, but not during it: this led the system to rapidly accumulate evidence for a reply only in the presence of a large overlap of the rotated object with the target object or its flipped version.

### *Model learning*

The model underwent two learning processes before being tested. These processes allow the system to respectively acquire the core capacity needed to predict/imagine the visual appearance of objects after a step of mental rotation (forward models: connections C1, C2, C3), and to associate to a certain object image the corresponding object orientation encoded, in an embodied fashion, in terms of corresponding wrist orientation (connections C16 and C17). These learning processes are intended to capture the processes of acquisition of the general capability to rotate objects that the human participants acquire during life before undergoing the psychological experiments on mental rotation.

The forward models of the system are implemented by connections C1, C2, and C3.

The forward models were trained with images formed by three randomly positioned black dots abstracting salient features, possibly isolated by attentional processes, of complete images seen in life. Based on pilot experiments we could see that this procedure ensured a fast training of the forward models. The filled dots shown in Figure 6.8 represent the image encoded in POCi whereas empty dots represent the desired image that POCi/s/r units should encode after one rotation step. This latter image was obtained by using “cvWarpAffine”, an image transformation function of the OpenCV library.

During training, PMCM selected a rotation action at random, and the selected rotation decided which of the forward models C1, C2 and C3 was trained. The three-dot images (Figure 6.8, black dots) was encoded in POCi as an input pattern of the forward model, whereas the predicted rotated three-dot images (Figure 6.8, white dots) were used as a desired output of POCi/s/r. Training was based on a delta rule (Eq. 6.4 in experiment 3).

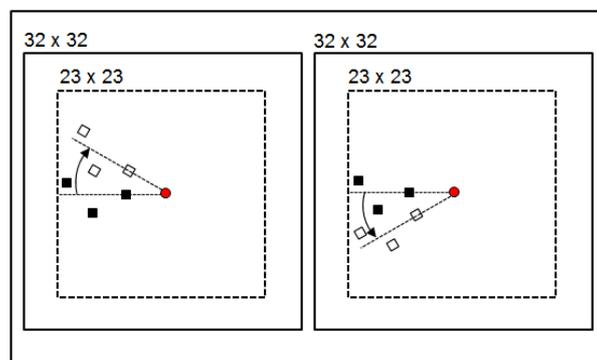

**Figure 6.8** Illustration of the procedure used to train the forward models of the system. The left panel illustrates the creation of a 30° clock-wise rotated image related to three random dots, whereas the right panel shows the effect of the opposite rotation. Arrows and dashed lines indicate the direction of rotation: the three full dots represent the image to be rotated whereas the three empty dots the resulting rotated (predicted) image. Small circles represent the centre of rotation. The three random dots were generated within the dashed square areas (23x23 pixels) to keep the image within the larger square image areas (32x32).

We now focus on the training of C16 (the training of C17 was done in the same way). This was based on exploratory motor movements (“motor babbling”) possibly mimicking the acquisition of motor skills in humans (Caligiore et al., 2008a). To implement this process, the robot was assumed to hold in hand an object whose shape was visually represented in POCp (and PFCT). The units of PPCp (similarly, the units of PPCt) had a Gaussian activation computed as follows:

$$PPCpA_j = \sum_i w_{ji} POCp_i \quad (6.14)$$

$$I_{win} = \max(PPCpA)$$

$$PPCp_j = G(\text{dist}(I_{win}, I_j))$$

where  $PPCpA_j$  is the activation potential of unit  $j$  of PPCp,  $POCp_i$  is the activation of units  $i$  of POCp,  $w_{ji}$  is the connection weight between the two units,  $\max$  is a function returning the index  $I_{win}$  of the unit of PPCp with maximum activation (winning unit),  $\text{dist}$  is a function computing the distance (in the neural space) between the winning unit and a given unit with index  $I_j$ . A supervised learning rule is used to train the connections C16 (and C17). This rule exploits some of the mechanisms of the (unsupervised) Kohonen learning rule (Kohonen, 2001). Specifically, instead of selecting the unit with the highest activation as *winning unit* of PPCp (and PPCt), as prescribed by the unsupervised Kohonen learning rule, we selected the unit corresponding to the current wrist posture. Based on this, we updated the connection weights C16 (and C17) as follows on the basis of the Kohonen learning rule:

$$\Delta w_{ji} = \eta PPCp_j (POCp_i - w_{ji}) \quad (6.15)$$

$$w_{ji} = w_{ji} / \sum_q w_{jq} \quad (6.16)$$

where  $\Delta w_{ji}$  is the weight update,  $\eta$  is the learning rate set to 0.1,  $PPCp_j$  is the Gaussian activation of output unit  $j$ ,  $POCp_i$  is the activation of the input unit  $i$ , and  $w_{ji}$  is the current weight value. Equation 6.15 ensures that the connection weights reaching highly

activated units of PPCp (PPCt) become progressively correlated with the input image. Equation 6.16 normalizes the connection weights after each update. After learning, when an object image with a clear orientation is perceived it tends to cause a concentrated activation of a few PPCp units encoding the wrist posture corresponding to it, whereas when a more difficult object is perceived the activation tends to be more similar (“flat”) for all units.

### **6.2.3 Results and discussion**

This section illustrates the results of the training and testing of the model. All results reported here refer to averages of data obtained by training and testing the model ten times. For each training and test, the trained connection weights of the model were assigned small random initial values. These might be considered equivalent to testing ten simulated different participants with the mental rotation tasks. Three types of data were recorded during the mental rotation tests. (1) The response times (RT): which is the number of steps used by the decision making process to trigger the YES/NO answer, and was measured for each disparity angle between the target and the rotated objects (recall that for each mental rotation cycle the neural competition underlying the decision making process performs up to ten cycles). (2) The error rates of the answers (ER): which is the number of times the model gives a wrong answers (i.e., it replies YES in correspondence to a flipped target object, or NO in correspondence to a basic target object), measured for each disparity angle between the target and the rotated objects. (3) The percent of correct responses (CR), averaged over all disparity angles.

Note that at this stage of the model development we aimed at reproducing the behavioural target data from the experiments with human participants only qualitatively. This, together with the knowledge on brain areas, allowed us to impose constraints on

and hence guide, the construction and progressive improvement of the model architecture, functioning, and learning mechanisms. Aiming to also reproduce the data quantitatively, would have required us to run a large number of experiments with the robot in order to tune the model parameters: this was practically very difficult and was also expected to produce little additional knowledge at this stage of the model development.

#### *Mental rotation and generalization*

Figure 6.9 illustrates the RT, ER, in correspondence to different disparity angles between the target and the rotated objects, and the CR, for the three tests Recog, Gen1, and Gen2. The figure shows that, for all tests, RT and ER increase with the stimuli disparity. This result qualitatively agrees with data obtained from experiments with humans (Shepard & Metzler, 1971; Wexler, Kosslyn, & Berthoz, 1998).

Figure 6.9 (b) shows that the model produces different ER profiles when tested with different sets of stimuli. In particular, the ER of Recog and Gen1 are similar, whereas those obtained with Gen2 are higher. This is also summarised by Figure 6.9c showing that the CR averaged over all disparity angles is rather lower for Gen2, around 59%, than for Recog and Gen 2, respectively around 79% and 86%. The greater RT for Gen2 for most disparity values, including the zero disparity value not requiring mental rotation, is due to a smaller difference, with respect to Recog and Gen1. Between the activations of PFC<sub>tm</sub> and PFC<sub>fm</sub>. The smaller difference leads to a slower competition between the PMC<sub>d</sub> units. A direct inspection of the behaviour of the model revealed the nature of the errors with Gen 2. In some cases, the model gives an answer even when the two images of the target/flipped target and rotated object do not have the same orientation. This can happen when the number of overlapping units in PFC<sub>tm</sub> or PFC<sub>fm</sub> are high enough to make the activity level of one of the two units in PMC<sub>d</sub> overcome

the threshold. In other words, in these cases the two images are so similar that they trigger a false recognition. On the other hand, in some other cases the model is able to correctly rotate the object to match it with the target but the number of overlapping neurons in PFC<sub>tm</sub> or PFC<sub>fm</sub> is too small. In these cases, the images are not similar enough and so there is a failed recognition. In this case, the model requires additional mental rotation steps to accumulate enough evidence and trigger an answer, thus in some (rare) cases arriving to the trial time-out causing a random, possibly wrong, answer.

These results show that the model was able to generalize the mental rotation ability to the never seen objects of Gen1 and Gen2 image sets. This ability was acquired on the basis of the Recog images used to train the image-wrist posture mappings (C16 and C17 connections), and the simple three-dot images used to train the forward models (C1, C2, and C3 connections). The results of the tests with Gen1 and Gen2 specify and quantify the generalization capabilities of the system. With Gen1, whose novel objects have many distinct features and a clear orientation axis, the model is able to rotate and compare the rotated and target objects in a good way, thus achieving RT and ER similar to those of the training set (Recog) and an slightly lower overall performance (CR). Instead, the objects of Gen2 are much more difficult to rotate and match as they have many features matching both the target and the flipped-target images. In this case the system performs more erratic rotations, resulting in a longer RT and several matching and decision making errors resulting in higher ER.

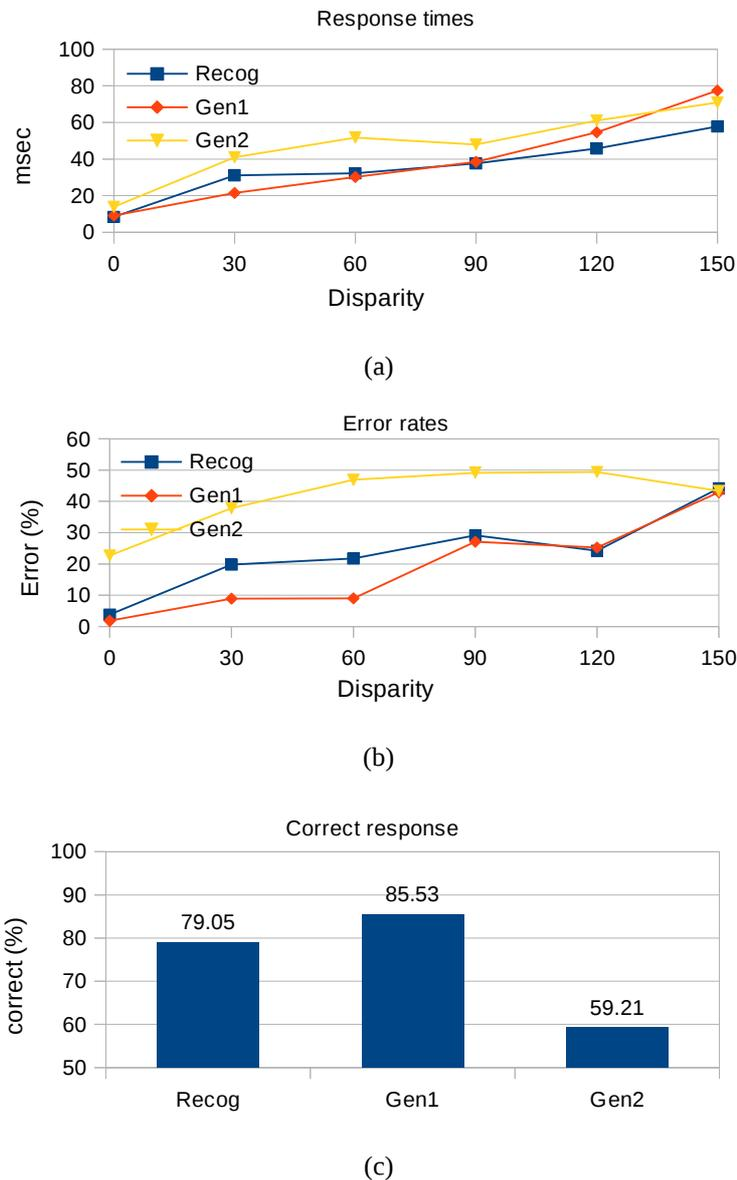

**Figure 6.9** Performance of the model during the three mental rotation tests: (a) Response times (RT); (b) Error rates (ER); (c) Correct response (CR).

*The role of overt movements during mental rotation, and a prediction of the model*

The model was also used to investigate the possible effects of performing overt movements on the mental rotation processes. In this respect, empirical data (e.g., Chu & Kita, 2011) shows that if the direction of the overt movement performed during the mental rotation task is congruent with the direction of the mental rotation, participants of the experiments are facilitated to solve the task (lower RT). Vice versa, if the direction of the overt movement is opposite with respect to the direction of the mental

rotation, people are struggle to solve the task (higher RT). Here we analysed how the robot's overt wrist movement affected the mental rotation processes during the three tests with the Recog, Gen1 and Gen2 images.

In the tests, the robot performed wrist movements that were either congruent (“match proprioception”) or incongruent (“mismatch proprioception”) with respect to the movement direction of the rotated object. In particular, during mental rotation the robot wrist movement signals were recorded through the wrist encoder, were opportunely scaled and then were used to modulate the activation of the somatosensory area PPCp of the model. For example, in the match proprioception condition if the model mentally rotated the current image to the left the robot moved its wrist to the left. In this case the same unit in PPCp was activated by two signals as a consequence of the congruence between the orientation of the mentally-rotated object and the orientation of the physically-rotated wrist, i.e., the signal supplied by the mental rotation process arising from POCp and the proprioceptive signal deriving from the wrist current posture. Instead, in the mismatch proprioception condition if the model mentally rotated the current image to the left, the robot moved its wrist to the right, and vice versa. This resulted in a mismatch between the orientation of the mentally rotated object and the physically rotated wrist. As a consequence, two opposite units in PPCp were activated by the two signals. For example, if the mental rotation process implied the activation of the POCp unit number 1 the proprioceptive signal caused the activation of the opposite unit number 6. If the mental rotation process implied the activation of the unit number 2, the proprioceptive signal activated the opposite unit number 5, and so on. In line with the empirical experiments run with humans, we expected that when the movement direction of the wrist matched the direction of mental rotation the resulting RT and ER would have decreased while CR would have increased.

The results of the tests, shown in the graphs at the left side of Figure 6.10, indicate that indeed the mismatch condition led to deterioration of the performance of the system with respect to the baseline condition in particular producing longer RT (Figure 6.10a) and in part higher ER for the cases with high disparity (Figure 6.10b), as also shown by the overall lower CR (Figure 6.10c). Instead, contrary to our expectation the matching condition did not lead to a relevant benefit. A closer observation of Figure 6.9a indicated that the latter result was due to a “ceiling effect” for which the performance of the baseline system was close to optimal and hence could not be improved by a congruent proprioception. This graph shows that the duration of the RT for different disparity values requiring a certain number  $n$  of mental-rotation steps is only slightly above  $n * 10$ . As the neural competition process underlying the system decision making runs for ten cycles for each mental rotation cycle, which indicates that the system performance is indeed close to being optimal.

So, why do empirical experiments show that a congruent proprioception can support mental rotation? We formulated the hypothesis in which congruent proprioception can improve mental rotation when this is made difficult by different factors such as noisy initial images, unreliable mental rotation processes, or noisy mappings from images to proprioception. To test this hypothesis we ran again the experiments by adding noise to PPCp, in particular adding a flat noise ranging in  $[-0.5, +0.5]$  to each unit of PPCp at each rotation step (the activation of the units was however cut within  $[0, 1]$ ). This condition captures in an abstract way the situations mentioned above that could make the mental rotation process more difficult. The expectation of these further tests was that noise added to PPCp would have deteriorated the performance with respect to the baseline condition and that in this case a congruent proprioception could indeed improve the mental rotation process.

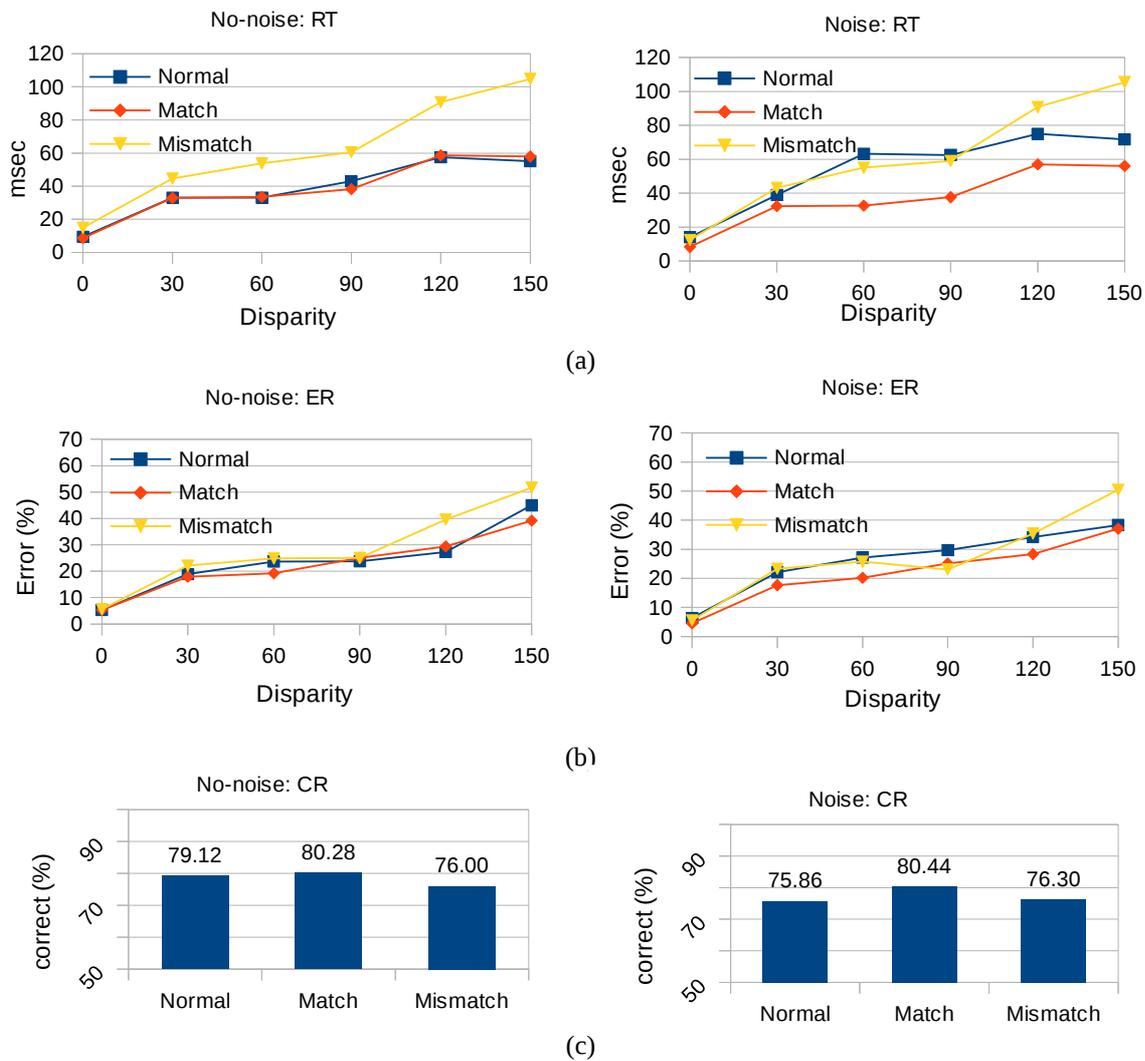
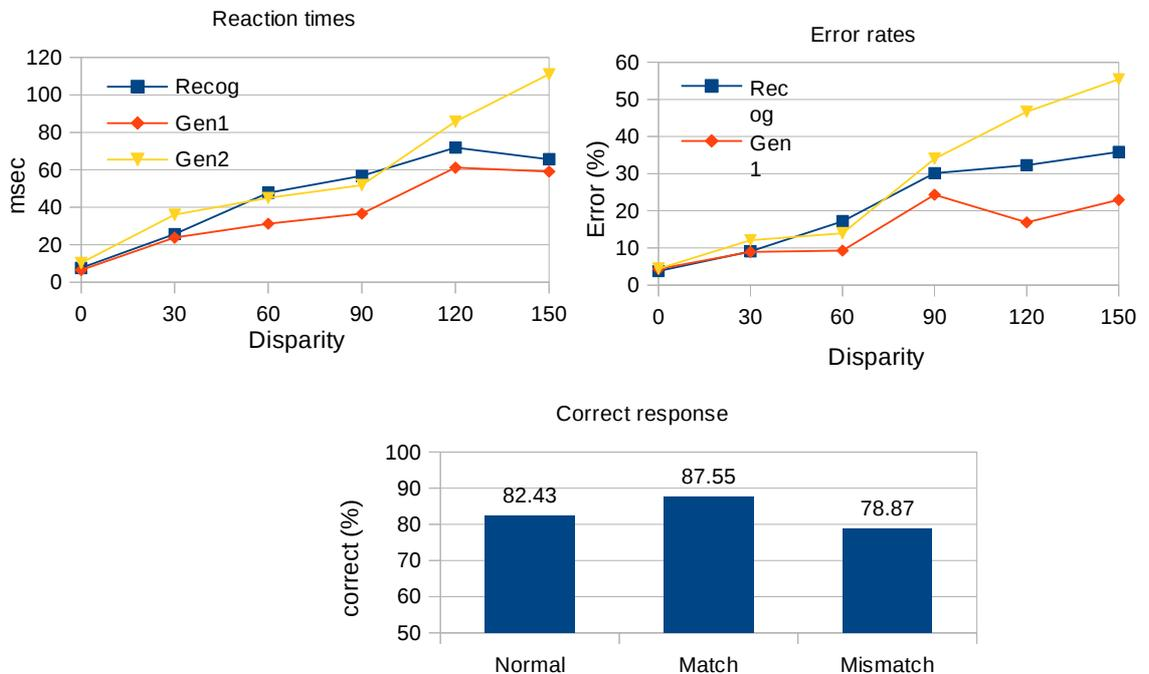

**Figure 6.10** Comparison of the results when supplying the model with match and mismatch of proprioceptive input from the robot wrist. (a) Response times. (b) Error rates. (c) Correct responses.

The graphs on the right side of Figure 6.10 show the results of the tests with noise. The graphs show that noise increases RT with respect to the condition with no noise and an incongruent proprioception impairs mental rotation RT only for high disparity conditions while not affecting much ER and CR. Moreover, now congruent proprioception improves the mental rotation process in terms of both RT and in part of ER/CR, thus confirming our hypothesis.

To test the robustness of the results on the effects of proprioception, we ran again the tests just described (with noise added to PPCp) with Gen1. The results, shown in Figure 6.11, confirm the overall effects found with the Recog dataset. In particular,

congruent and incongruent proprioception tend to respectively improve (for high disparity) and deteriorate the performance of the model in terms of RT (Figure 6.11a). The effect is even more pronounced when measured in terms of ER and CR (Figure 6.11b and 6.11c respectively).



**Figure 6.11** Comparison of the results when the model receives congruent or incongruent proprioception in the case of the Gen1 image dataset.

The result for which a proprioception coherent with mental rotation improves it only in cases where mental rotation is made difficult by noise sources represents. This is to the best of our knowledge, a prediction of the model. This prediction could be tested in future psychological experiments by tuning the difficulty of the mental rotation task, e.g., by affecting the object images with noise.

#### *Analysis of internal functioning of the model*

This sub-section presents some analyses that illustrate the internal functioning of the model that produced the performance illustrated in the previous two sub-sections. Figure 6.12 illustrates the activation of key areas of the model when it perceives sample

images, containing different target/rotated object couples, drawn from the Recog, Gen1 and Gen2 datasets. Figure 6.12a shows a trial where the model gives an answer for an image of the Recog dataset using five steps of mental rotation. The graphs of the figure allow the visualisation of key aspects of the functioning of the model during mental rotation. PFCt encodes the edges of the still target object image (in this example it has an horizontal axis) and PFCft encodes its flipped version. POCi encodes the input to the forward models: at step 1 this corresponds to the image of the rotated object. POCp represents the predicted image after the mental rotation (recall that at step 1 this corresponds to a no-rotation movement, so the predicted image is as the one of POCi). PPCd encodes a combination of the desired wrist posture corresponding to the target object orientation and of the wrist posture corresponding to the rotated object. This combination is the basis on which to trigger the proper movement at the level of PMCM. At step 1 this encodes a left (anti-clockwise) mental rotation. At step 2 this mental rotation results in a predicted image of the “rotated object” (POCp) now actually rotated anti-clockwise for 30°. Notice the effects of the following rotations (PMCM) on the mental image of the system encoded in POCp. At step 2, the model does not rotate the object as it should (recall that PMCM performs stochastic selections of rotation movements based on their evidence). While the model is performing these mental rotations, PFCtm and PFCfm compute the matching of the mental image (POCp) with the target and its flipped version (PFCt and PFCf). Notice how from step 1 to step 4 PFCtm and PFCfm involve a similar number of active units and so the system decision making process (PMCD) does not produce any response. When at step 5 the PFCtm reveals a matching with the target that is substantially higher than the matching with its flipped version (PFCfm), then the evidence in support of the YES reply accumulates, overcomes the decision threshold and therefore the related action is triggered.

Mental rotation step	PFCt (target)	PFCft (flipped target)	POCi (forward models' input)	POCp (predicted object)	PPCd (= desired * current posture)	PMCM (planned rotation)	PFCtm (target matching)	PFCfm (flipped target matching)	PMCD (YES, NO decision)
1						<input type="radio"/> <input type="radio"/> <input checked="" type="radio"/>			<input type="radio"/> Y <input type="radio"/> N
2						<input type="radio"/> <input checked="" type="radio"/> <input type="radio"/>			<input type="radio"/> Y <input type="radio"/> N
3						<input type="radio"/> <input type="radio"/> <input checked="" type="radio"/>			<input type="radio"/> Y <input type="radio"/> N
4						<input type="radio"/> <input type="radio"/> <input checked="" type="radio"/>			<input type="radio"/> Y <input type="radio"/> N
5						<input type="radio"/> <input type="radio"/> <input checked="" type="radio"/>			<input checked="" type="radio"/> Y <input type="radio"/> N

(a) Recog

Mental rotation step	PFCt (target)	PFCft (flipped target)	POCi (forward models' input)	POCp (predicted object)	PPCd (= desired * current posture)	PMCM (planned rotation)	PFCtm (target matching)	PFCfm (flipped target matching)	PMCD (YES, NO decision)
1						<input type="radio"/> <input type="radio"/> <input checked="" type="radio"/>			<input type="radio"/> Y <input type="radio"/> N
2						<input type="radio"/> <input type="radio"/> <input checked="" type="radio"/>			<input type="radio"/> Y <input type="radio"/> N
3						<input type="radio"/> <input type="radio"/> <input checked="" type="radio"/>			<input type="radio"/> Y <input type="radio"/> N
4						<input type="radio"/> <input checked="" type="radio"/> <input type="radio"/>			<input checked="" type="radio"/> Y <input type="radio"/> N

(b) Gen1

**Figure 6.12** Activation of different areas of the model, indicated in the top row of each graph panel, while the system mentally rotates objects from the three datasets. (a) Recog. (b) Gen1.

Mental rotation step	PFCt (target)	PFCft (flipped target)	POCi (forward models' input)	POCp (predicted object)	PPCd (= desired * current posture)	PMCm (planned rotation)	PFCtm (target matching)	PFCfm (flipped target matching)	PMCd (YES, NO decision)
1									
2									
3									
4									

(c) Gen2

**Figure 6.12** Activation of different areas of the model, indicated in the top row of each graph panel, while the system mentally rotates objects from the three datasets. (c) Gen2.

Figure 6.12b shows an example of mental rotation of an image taken from Gen1. The mental-rotation process and the final decision made by the system, are fully correct, based on the capacity of the system to properly rotate the object (see the sequence of states of POCp during the mental rotation).

Figure 6.12c reports an example with an image from Gen2. In this case the image is much more challenging and after some attempts to rotate the object mentally, the system sees a strong resemblance between the rotated object and the target image and so produces a “YES” reply before successfully rotating the object (in this case the decision is fortuitously correct).

Figure 6.13 reports the visualisation of some key areas of the system in the case of mental rotation of the same object used and considered in Figure 6.12a, but this time with the addition of proprioceptive information to PPCp that is congruent or incongruent with the mental rotation process.

Mental rotation step	PFCt (target)	PFCft (flipped target)	POCi (forward models' input)	POCp (predicted object)	PPCd (= desired * current posture)	PMCm (planned rotation)	PFCtm (target matching)	PFCfm (flipped t. matching)	PMCd (YES, NO decision)
1									
2									
3									
4									

(a) Gen1, congruent proprioception

Mental rotation step	PFCt (target)	PFCft (flipped target)	POCi (forward models' input)	POCp (predicted object)	PPCd (= desired * current posture)	PMCm (planned rotation)	PFCtm (target matching)	PFCfm (flipped t. matching)	PMCd (YES, NO decision)
1									
2									
3									
4									
5									
6									

(b) Gen1, incongruent proprioception

**Figure 6.13** Activation of key areas of the model when it is supplied proprioceptive information in the case of mental rotation of the same object used in Figure 6.12a. (a) Case where proprioception is congruent with mental rotation. (b) Case where proprioception is incongruent with mental rotation.

Figure 6.13a shows how when proprioceptive information is congruent it can help the system to more reliably perform mental rotation, so taking four steps (Figure 6.13a) rather than five (Figure 6.12a) to successfully accomplish the mental rotation. This better performance is due to the fact that with congruent proprioception the system performs a better mental simulation of the wrist rotation (comparing the activation of PPCd in the two cases). Instead, Figure 6.13b shows how an incongruent proprioception leads the system to accomplish the full rotation in an inefficient way (six steps) as the mental rotation processes of the model are more erratic.

# Chapter 7

## **The Role of Sensorimotor Learning and Mental Imagery in the Development of Tool use**

This chapter demonstrates that fundamental mechanisms such as mental imagery and affordances, that were applied in the experiments of the two previous chapters, can be acquired by robots through the processes of sensorimotor learning. The experiment of this chapter involves a simple tool use scenario in which a humanoid robot learns to use a tool in its hand to retrieve an out-of-reach object through trial and error. The purpose of this experiment is to extend the extent of exploiting mental imagery in humanoid robots. The iCub simulator was used to simulate infant participants which will be called “infant robots”. The Dynamic Movement Primitives (DMPs) framework underlies the movements of the robots are underlie (Schaal, 2006). By applying learning mechanisms of reinforcement learning and intrinsic motivations to train the DMPs, exploratory behaviours in the infant robots can be simulated. Importantly, the experiment demonstrates that mental imagery can be used as an alternative resource replacing the use of overt movements in the learning of action sequencing. By mean of planning, the robots can solve the tool use task without exhibiting overt movements. This chapter also proposes two hypotheses on the developmental characteristic of tool use found in human infants. Both hypotheses focus on the age of the human infants as the main effect of the development. The first hypothesis interprets the infants' age as different in a number of acquired motor skills. The latter treats the infants' age as the period to familiarise with a given tool use task before testing.

## 7.1 Experiment 5: Tool Use Development in Infant Robots

### 7.1.1 Introduction

A simple tool use scenario, such as using a rake-like tool to retrieve an out-of-reach toy, has proven too difficult for human infants aged younger than 18 months to solve (Rat-Fischer et al., 2012). As shown in their empirical data, tool use performance increased functions to the infants' age. In particular, older infants have a higher success rate in the test than the younger ones. The authors also suggest that the infants begin to have a comprehension of how to use tools at the age of 18 months. Before that age, e.g., 14 or 16 months, their tool use performance remains variant and contingent. Infant participants aged younger than 18 months almost fail in the task that required tool use understanding (e.g., when the tool's tip is located far from the toy). In addition, the demonstration of how to use a rake tool to retrieve a toy can help infants that fail in the test to be able to succeed spontaneously when they encounter that task again. Interestingly, it was the age of 18 months that the infants can gain benefit from the demonstration session.

According to Piaget's theory of child development, the age of 18 months is the beginning of the sensorimotor stage 6 that infants begin to have an ability of using mental imagery (Piaget, 1952). Thus, the demonstration (i.e., Rat-Fischer et al., 2012) might provide missing information about actions and outcomes of how to solve the task to the infants. The infants might fulfil their understanding of how to solve the task through the use of mental imagery. When they encounter the task again, only recalling a suitable action that produces a proper outcome is required to complete the task.

The infants' tool use ability can be viewed as a development from their existing manual skills (Kahrs, Jung & Lockman, 2013; Kahrs and Lockman 2014). Furthermore,

this ability gradually increases function to the experience the infants have on the exploration on object manipulation (Lockman, 2000; Gibson and Pick, 2000). In agreement with these views, the capability of using tools of younger infants seems inefficient and varied comparing to the older ones. Due to their age, younger infants should have less sensorimotor experience which limit the number of skills that can be acquired directly. Some researchers assumed that, at the beginning, infants can exhibit simple tool use competence using only simple sensorimotor knowledge such as action and perception (Lockman, 2000). While in the later stage, tool use required more precise knowledge about object-object interactions and the ability to manipulate an internal representation of that knowledge (Guerin, Kruger, & Kraft, 2013).

Affordances play a central role linking together perception, action, and cognition (Gibson, 1986). However, infants are not endowed with an ability to perceive affordance of objects at birth. To understand the world around them, through affordances, the infants have to explore this capability. The outcome manifests as play (E.J. Gibson, 1988).

Although literature regarding tool use in human infants suggests the use of mental imagery, the work on robots suggested the important role of affordances (Stoytchev, 2005; Tikhanoff et al., 2013); however, there are no computational models that addressed these issues systematically thus far. This study is the first attempt to reveal the role of both mental imagery and affordances in tool use competence.

The model aims at reproducing a characteristic of tool use development (qualitatively) found in human infants. The key idea is that the development could be characterised by a number of skills the infants have acquired. Young infants should have a small number of motor skills due to the length of time (their age) they had in the sensorimotor learning period. Therefore, their tool use performance should be very

limited. In contrast, older infants performed the task better because they have a high number of motor skills. The reason a higher number of skills results in better performance is that there is a higher chance that suitable skills for solving a given tool use task consist in a higher set. In this framework, if there are no suitable skills, tool use competence will not be possible. In addition, we also propose another hypothesis that different periods of time (training trials) the infants used to familiarise with a tool use scenario would result in differences in tool use performance. Similar to the case of skills, young infants will have a small number of training trials while older infants will have a higher number trials. In term of development, gradually increasing of these numbers, i.e., skills, training trials, should result in an increase of tool use performance.

The present model puts together the ideas on intrinsic motivations, sensorimotor learning, affordances, mental imagery and problem-solving. In particular, intrinsic motivation serves as an important aspect that drives/guides the processes of sensorimotor learning, which benefits the acquisition and sharpening of tool use ability in infant robots.

In this study, the ability to use a tool in robots is possible through affordances, while the developmental characteristic is constrained by a number of motor skills acquired by the robots. Importantly, mental imagery can be used to replace overt movements in the problem-solving processes, i.e., action sequencing. The next section, methods, will give more details on mechanisms underlying this framework including some definitions of components used. Section III reports results obtained by the model and the final section draws a conclusion.

### 7.1.2 Methods

This section describes components and algorithms applied in the implementation of a neurobotic model account for tool use development in a humanoid robotic platform. The iCub simulator will be used as simulated infant participants (Tikhanoff et al., 2008). In order to simulate tool use competence in robots, DMPs were used to underlie movements/skills of the robots.

#### *Hypotheses on tool use development:*

According to Rat-Fischer et al. (2012), tool use performance is constrained by an infant's age, whereby an increase in age results in a better performance in the tool use test. To simulate this finding in robots through computational modelling, we interpret the age in motor skills and training trials.

- ***HP1) The infants' age as a number of acquired motor skills.***

This hypothesis refer to the variation of the number of skills different infant can acquire. Simulated infants will have a different number of motor skills. For instance, the youngest robots, aged 14 months, the youngest, will have 2 motor skills. This number will be increased to be 3, 4, 5, and 6 for the infant robots aged 16, 18, 20, and 22 months, respectively. Note that all infants are assumed to have the same basic skills of Pulling and Touching. The difference is in the interaction skills in which additional skill(s) will be selected randomly from the set of remaining interaction skills. Thus, it is possible that robots from the same age group can have different skills. The individual difference also characterised by this setting.

- ***HP2) The infants' age as a number of training trials.***

In this hypothesis, a number of training trials refers to the number of practice with one of the two tool use situations (i.e., tool behind the toy, tool far from the toy) that the

simulated infants at different ages practice/familiarise with before testing. For example, 0 and 2 trials will be used as corresponding to the infant robots aged 14 months which exhibit little practice (play) with the tool and the toy, while 4, 6, 8 and 10 trials correspond to the age of 16, 18, 20 and 22 months, respectively. Increasing of the number of training trials should increase the performance of using a tool in a sense that the infant robots have more time to familiarise with a given tool use task.

Tool use scenarios:

There is a table, a rigid box, placed in front of the robot (see Figure 7.1). Tool use scenarios will be set on top of this table. There will be a toy placed on the table at a location that too far away from the robot's reach. The iCub simulator was set to hold a rake-like tool permanently with its right hand. Tool use competence will require only the right arm of the robot. The tool is coloured in green, consists of a long stick handle and a flat rectangle tip. The tool was used to extend the length of reach of the robot. Movements caused by the right arm will cause change on the tool directly.

However, demonstrating the processes of action acquisition of all possible actions, or even focusing on one arm that move with a tool, can be a daunting task. Thus, only two types of actions that the robot exhibits with the tool will be considered as mandatory for our initial tool use scenarios. They are “Pulling” and “Interaction” actions. What makes each action different is its outcome. For example, pulling is an action that make the toy moves to a reachable area while the interaction actions refer to the effects when the tool interacts with the toy e.g., touching, moving. In detail, interaction action can be varied in five different types of movement outcomes.



**Figure 7.1** The iCub simulator and a sample tool use scenario

*Interaction detection:*

Visual information taken from the robot's camera alone is not enough to determine the interaction between two objects in the robot's stationary space due to the reduced accuracy of the depth information and physical interaction calculated using 2D images (1 camera). Thus, the present system uses positions of objects in 3D spaces provided by the iCub simulator instead. In real robot, this technique might be replaced with other mechanisms that are able to detect the depth and the interaction between two objects e.g., 3D camera system, or effects on the robot's arm itself such as touch and force sensors.

*IM-detector:*

This mechanism was used to monitor interesting events caused by movements of the robot. Depending on the type of interesting event that is set to the module, the IM-detector will acknowledge the occurrence of that event to the system which will be used to determine a reward of currently perform action.

*Distal goals:*

A set of neurons underlie this mechanism. It will be trained, through network connection C2, during the period of skill acquisition. Each was used as a distal goal of a particular skill. A high activation of these neurons indicated that the corresponding skill

has been obtained by the system already. The purpose of this mechanism is to prevent the acquisition of the same skill, such as two movements that achieve the same goal. Thus, even the IM-detector reports the arising of an interesting event; however, if the distal goal is active the system will not learn to achieve that event.

*Initial postures and tool use situations:*

Initial postures refer to the configuration of the right arm of the robot. Differentiation on the joints' value results in changing the robot's posture. To simplify sensorimotor exploration and an acquisition of tool use competence, we assumed that the robots already hold the rake tool in its right hand permanently, and will be facing with only four different situations during their sensorimotor period. From the robot's view, movements on its arm will affect its visual perception directly. As illustrated in Figure 7.2, the four postures directly cause four different tool use situations, the different spatial gap between the tool's tip and the toy.

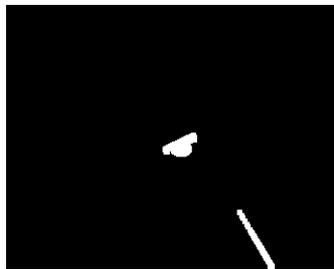
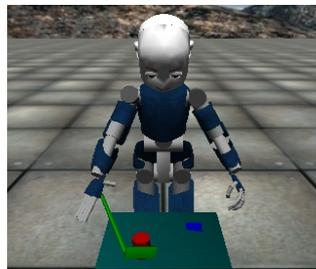

(a) Posture-1

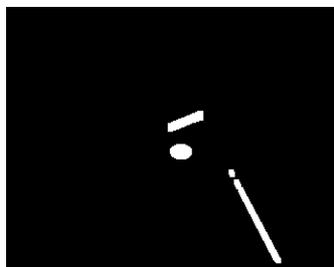
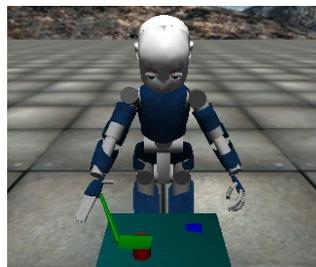

(b) Posture-2

**Figure 7.2** Four initial postures and four initial tool use situations. (a) Posture-1. (b) Posture-2.

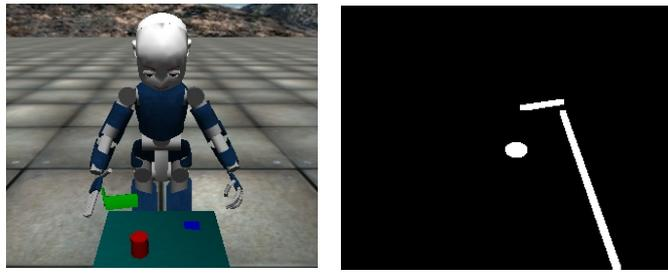

(c) Posture-3



(d) Posture-4

**Figure 7.2** Four initial postures and four initial tool use situations. (c) Posture-3. (d) Posture-4.

*Rewarding scheme:*

This work applies reward-based learning mechanisms to guide learning components of the system, i.e., neural networks. As reward-based learning, teaching signals for a training of the neural network components will be characterised by a specific reward that was found during exploration. In the learning mode, only one type of event will be monitored assume as the infants focus on that event in order to master it.

*Interesting events:*

In order to demonstrate that tool use ability can be acquired by robots in a reasonable amount of time, we have set a scheme that the change of the toy caused by the interaction with the tool is suitable to make a simple tool use scenario. From this interaction, six types of event are assumed to happen during exploration (movements of the robot's arm with tool, see Figure 7.3):

- The situation that the toy was moved (by the tool) into a reachable area

(Retrieving, Pulling),

- The situation that the tool touched the top part of the toy (Touch),
- The situation that the toy was moved toward the robot (South),
- The situation that the toy was moved away from the robot (North),
- The situation that the toy was moved to the left (West), and
- The situation that the toy was moved to the right (East).

In human infants, they might get surprised when these events happen because the object of desire (toy) was moved. So, intrinsic motivation is assumed to play a role here. Note that the retrieving event is different from the others. This is because this event is a situation that the infant can grab the toy directly, so it may be considered as causing an external reward to the infants. While other events obviously cannot bring the toy into reach, so they are assumed to cause internal rewards. Specifically, to make the outcome of these situation more stable (from the robot's visual perception), the system was set so that as soon as one of these events arises, the robot will stop moving (actuators). This reduces the variation of the toy's position that is changed corresponding to the interaction with the tool. Current parameters of the running DMP and the position of objects will be used to initial the learning process.

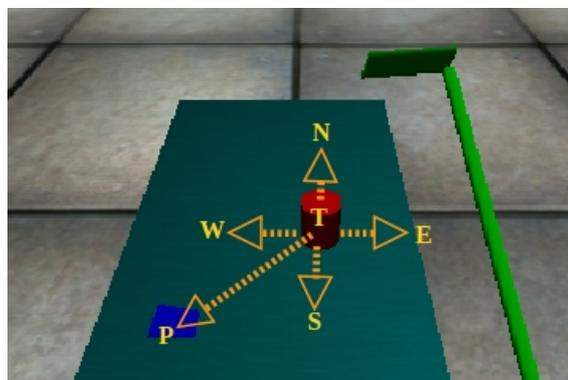

**Figure 7.3** Interesting events caused by the interaction between the tool and the toy. The arrows indicated movement directions of the toy when interacting with the tool.

*Constraints on skill acquisition:*

By doing a preliminary observation on an occurrence of the interesting events from different initial posture, we found that there is a constraint of physical interaction that some events cannot be discovered if starting from some initial postures. Furthermore, starting from some initial postures, the robot cannot learn to achieve some goals (interesting events). For example, data in the first row column “Interesting events” of table 1 indicates that starting from initial posture-1 cannot discover event-2, 4, and 6. While in the column “Skills”, the first column means that skill-P (Pulling) can be achieved only if starting from initial posture-1 and 2. It seems like data of the two columns (Interesting events, Skills) are very similar except the case of posture-2. Starting from Posture-2 can be learned to achieve Skill-P even though the event-1 (the toy enter a reachable area) cannot be discovered by this posture.

**Table 7.1** Constraint for skill acquisition.

Initial postures	Interesting events (IMEs)						Skills (DMPs)					
	1	2	3	4	5	6	P	T	S	N	W	E
Posture-1	1	0	1	0	1	0	1	0	1	0	1	0
Posture-2	0	1	1	0	1	0	1	1	1	0	1	0
Posture-3	0	1	1	1	1	1	0	1	1	1	1	1
Posture-4	0	1	1	1	1	1	0	1	1	1	1	1

1: yes, possible; 0: no, impossible

***Model architecture:***

Based on our computational models regarding mental rotation (Seepanomwan et al., 2013a; 2013b), the present model on tool use development has been designed to include four parts of the cortical area as illustrated in Figure 3. We believe that, by means of information/cognitive processing, these brain areas might be involved in the emergence of tool use. In addition, the model consists of an intrinsic motivation mechanism through motivation activation unit and HIP. This mechanism plays a key role in shaping what the system can learn and determining when the learning should be started.

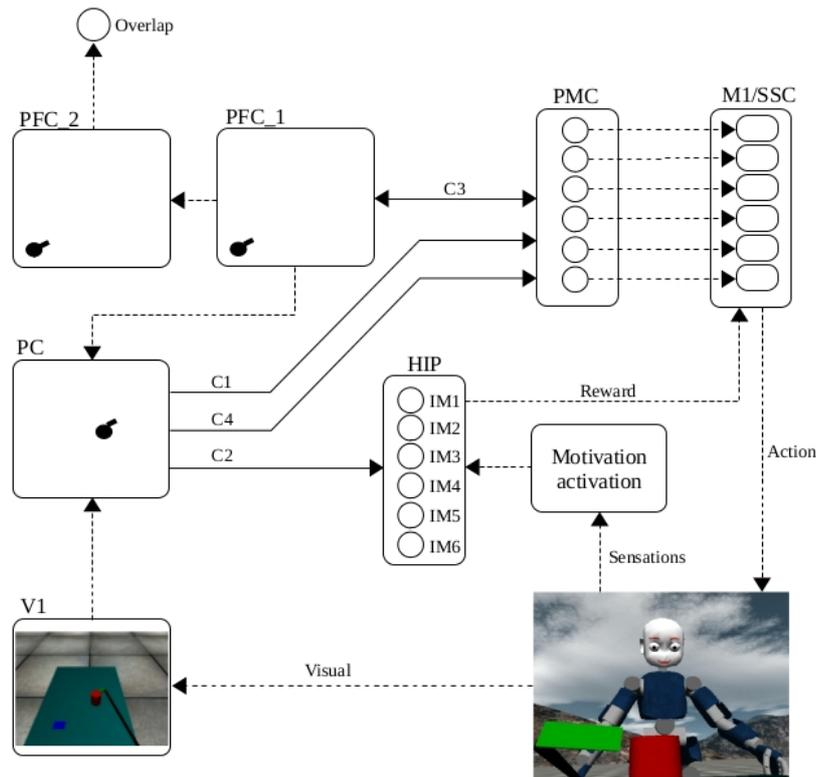

**Figure 7.4** The model of tool use development

The model consists of several components corresponding to the cortical areas of the brain which we believe are involved during an acquisition and performing of tool use. They are primary visual cortex (V1), parietal cortex (PC), premotor cortex (PMC), primary motor cortex (M1) and prefrontal cortex (PFC). In addition, we introduce the role of motivations into the system through the motivation activation and Hippocampus (HIP) components. These components serve as mechanisms that monitor coming events and evaluate specific rewards to the system.

Specifically, the V1 is formed by a 320 x 240 neural map. It is used to store visual information captured directly from the robot's camera. PC is responsible for storing spatial information on the tool and the toy that represents tool use situation. It is formed by 320x240 neurons, the same size as of V1. Note that information from V1 is passed through colour filtering processes before using neural activation of the PC. The PMC is formed by 10 neurons responsible for affordance interpretation. M1 is also formed by

10 units. Each neuron in the PMC has a direct link to one unit in M1. This means that activation of the PMC's neurons causes execution of the M1's unit directly. The PFC consists of two components which will be used for storing and manipulating mental images. HIP is formed by 6 neurons corresponding to 6 different goals used in this work.

The term motivation activation used here refers to a mechanism that guides the process of skill acquisition in infant robots. In humans, by means of motivation activation, infants might get surprised when something that they are paying attention to has changed. However, in robots, it is of interest how they can be interested in the occurrence of an unexpected event, and how they can distinguish some events as interesting and other events as not. To simplify this, we use the change of the environment as a source of attraction. As a critic, the motivation activation mechanism was applied to detect the change of the environment caused by movements of the robot. Thus, the reward of 1 will be given to the system when movements of the robot have revealed a focused goal, otherwise the reward will be 0. This mechanism is assumed to work as dopamine neurons which are fired when an agent encounters novel/unpredicted situations.

Information propagates among neural maps through connections. There are 4 connections and 3 types of learning algorithms involved in this study. C1 and C2 are Hebbian connections while C3 is a special type of Kohonen learning which is learned in a supervised fashion. Furthermore, this connection can propagate information in both ways, i.e., from PFC\_1 to PMC, and also from PMC back to PFC\_1. A mental image creation is possible through this connection. The C4 is a Q-learning connection; it is responsible for accumulating knowledge about tool use competence exhibited during training. Below are three training algorithms used in the model.

**Affordances** in this work refer to actions/skills that are suitable to manipulate a perceived tool use situation rather than an object in which suitable action(s) will be available to robots when they encounter with familiar tool use situation. In more details, affordances are an association between tool use situations and their suitable actions. The perceived situation activates suitable actions that leads the robots to achieve a particular goal. This association will be formed during skill acquisition. Note that one tool use situation is able to activate more than one action, because it is possible that from one tool use situation can lead to an achievement of different goals.

**Mental imagery** emerges also through the processes of sensorimotor learning especially during the processes of skill acquisition. In this work, mental imagery refers to the ability to predict next state of the intended action constraints by a being perceived situation. It will be used to anticipate the planning of the robots. Ideally, the ability of using mental imagery will be used to replace the processes of action-perception in which the robot does not have to exhibit overt action instead it can use mental imagery to fulfil the outcome of the intend action.

The model uses a supervised version of the SOM as a special connection that is capable of propagating information in both direction (bi-directional). In detail, this connection was trained using basic input-output training patterns, but in behaving it is capable to generate input from the present output (feed-backward). Note that this characteristic is possible by using of one-to-one training patterns. The feed-backward process will be used to generate a mental image.

**Q-Learning** is a reinforcement learning technique invented specifically for learning of action sequencing (Watkins & Dayan, 1992). Like traditional reinforcement learning, the q-learning process involves action, state, and reward to accumulate the knowledge regards an encountering task. The reward is used as a guidance for selection of the next

action. Through iteration processes of rewarding and updating mechanisms, the q-learning can lead the system to achieve an optimal solution (obtain maximum reward). In this work, the processes that underlie Q-learning were adapted to train connection weights (Eq. 7.1) of the neural networks.

$$\Delta w_{wini} = \eta((reward_t - \gamma * qMax_t) - qWin_{t-1}) x_{it-1} \quad (7.1)$$

where  $\Delta w_{wini}$  is the change of the connection weight between unit  $i$  and a winning unit  $win$ ,  $\eta$  is a learning rate ( $\eta = 0.0001$ ),  $reward_t$  is a reward that was given to the system at time step  $t$ ,  $qMax_t$  is a highest activation of output unit at time  $t$ ,  $qWin_t$  is an activation of output unit at time  $t$  that was selected using softmax function,  $\gamma$  is a discount factor which is set to 0.8, and  $x_{it-1}$  is the activation of input unit  $i$  at the previous time step  $t-1$ .

PMC was used as motor preparation while M1 serves as motor execution. The direct link between them was constructed manually in a sense that one motor preparation (i.e., affordance) activates one corresponding motor command (i.e., action). Note that this like is not a connection. Ten neurons of this map were used to represent affordance interpretation of the tool use situation.

Six neurons of the HIP were used to indicate whether or not the system can achieve a particular goal from a being perceived tool use situation. As distal goals, one of these neurons (corresponding to one specific goal) will be activated if the system has mastered suitable actions to do so. This ensures that the system will not learn to acquire the same action (using different PMC neuron) to achieve the same goal. Ideally, high activation of these neurons means that a being perceived tool use situation is not new to the robot. This characteristic can be trained using Hebbian learning through connection C2.

## ***Definitions:***

### *Exploratory behaviours:*

As in human infants, the robots exhibit random movements in order to learn the effects of their own actions on the environment. The rake tool was attached permanently to its right hand. The toy was placed at a fixed position on a table, far away from the robot's reach. In this scenario, the tool extends the length of the robot's reach, and it is mandatory in retrieving the toy. Random movements on the right arm with the tool should be able to cause interaction between the tool and the toy. We believe that this interaction leads to the acquisition of tool use ability.

### *Intrinsically motivated events (IMEs):*

The term intrinsically motivated events refers to the events that distract the infants' attention. In this work, we define manually that what the robot can detect will indirectly refer to what skill the robot can discover. This work assumes that the IMEs are a source of motivation that drive the infants to practice the underlying action that cause them which will result as skills. The individual difference is set according to the number of IMEs the robot can detect. Any interesting event is revealed by chance, thus different robots can discover different events and acquire different skills. Furthermore, some skills may be useful for solving a given tool use task while the others may not be. As a consequence, it is possible that different infants from the same age group can or cannot solve the same given tool use task.

Actions can be distinguished as intrinsically or extrinsically motivated by considering the intention behind them. For example, pulling action is an extrinsically motivated action if the intention of doing pulling is to bring food back for consuming such as when the infants are hungry. In contrast, if the intention is to bring other objects

such as toys back for play this might be the case of intrinsically motivated action. Therefore, pulling and interaction actions of this work will be determined as intrinsically motivated actions. These actions do not cause any external reward to the infants; instead, they cause something interesting that distract the infants' attention such as the toy was moving when touching with the tool. We assume that this kind of events make the infants keep doing that actions in order to constantly make that particular interesting events happened.

*Skills:*

We also assume that an interesting event is a source of pleasure to infants in a way that they feel joy when it happens. In order to make a particular event happen constantly, they have to practice the action underlying it. Therefore, as soon as an interesting event happens, it is possible to say that the infants might repeat their recent action in order to make the event happen again. This behaviour is assumed as play. During this practice/play, other cognitive skills such as affordances and mental imagery also emerge.

According to Rat-Fischer et al (2012), infants see the tool and the toy as one composite object when they are connected visually or physically. Grasping on the handle of the tool is interpreted as grasping on a part of the toy. Therefore, all infants in their study can succeed in the case that the tool and the toy are connected physically and obtain high percentage in the case of visually connected (no spatial gap). From this evidence, we assume that pulling is an action that infants develop before interaction action since it seems to derive from a simple grasping and retrieving on a composite object. Furthermore, doing pulling is not required a tool, in general.

However, when the tool is located far from the toy, pulling cannot bring the toy into reach. In order to succeed in this situation, intermediate action, such as an action that

can bring the tool goes behind the toy, is required. We propose that an experience on object-to-object interaction leads to an acquisition of intermediate actions which will be called interaction actions.

### ***Model learning:***

The model starts the learning processes by capturing the current tool use situation via the robot's camera. The visual input consists of two objects, the toy and the tool. In order to easier distinction between the two objects, they were set with a different colour. The toy was coloured in red while the tool was coloured in green. The model uses a colour-based detection and focuses only on the two colours. Therefore, only changing of these two objects will affect the visual input or tool use scenarios. Thus, the tool is moved by movements of the robot right arm, while the toy will be moved only when it was touched by the tool. Tool use scenarios are variations between actions exhibited by movements of the robot's arm with the tool and the interaction with the toy. Furthermore, some movements might cause the situation that the toy is moved in a certain direction when touching with the tool, which will be considered as intrinsically motivated events.

### ***Learning Algorithms:***

Learning processes of the model consist of 2 stages. The first stage (Figure 7.5) refers to the period that an infant robot exhibits exploratory behaviour, while the latter (Figure 7.6) refers to the period that the robot accumulates knowledge of how to retrieve the toy based on the motor skills it has acquired.

## **#Skill Acquisition**

### **Initialisation**

10 free DMPs

6 empty distal goals

Set Acquired skill table = empty

Set Desired skills table = 6 (it can be 2, 3, 4, 5, 6)

Randomly enabling specific number of IM-detector

### **A. Exploration**

Loop until Acquired skill table == Desired skill table

    Randomly select one free DMP (1..10) as *cDMP*

    Loop until the *cDMP* is marked as taken

        Reinitialise the *cDMP* with one randomly select initial posture (1..4)

        Adding noise to the goal parameters of *cDMP*

        Perform movement (roll out the *cDMP*)

        Monitor the interaction between the tool and the toy

        If a new interesting event happened, *cIMEs*

            stop moving and capture *cDMP*'s parameters

**switch to B. (Learning)**

            mark *cDMP* as taken

            Update the Acquired skill table, disable current IM-detector

### **B. Learning**

epoch = 0

Loop until the *cDMP* stop improving (the competence's change < 0.05) or epoch == 10

    For (initial posture = 1 to 4)

        For (sample = 1 to 10)

            Apply the initial posture to the robot

            Restore *cDMP*

            Generate the goal and shape parameters based on *cDMP*'s parameters

            Perform movement

            Compute cost for each sample based on the achievement of *cIMEs*

        Update *cDMP* ( $PI^{BB}$ )

        Train 10 times the affordance connection (C1) with the teaching signal of number of success/10

    Calculate the DMP's competence

    epoch++

### **#Calculate the DMP's competency**

For (initial posture = 1 to 4)

    Apply the initial posture to the robot

    Restore *cDMP*

    Perform movement (roll out the DMP)

    If success

        Train 10 times the distal goal connection (C2) with the teaching signal of 1

        Train 50 times the SOM (C3)

Competency value = number of success / 40

**Figure 7.5** Learning algorithm on skill acquisition

### #Action Sequencing

```
Set the training_mode, 0: Training, 1: Testing
Set the child_mode, 0: Reactive child, 1: Planning children
Set the initial_posture, 1: Tool-behind-toy, 4: Tool-far-from-Toy
Set the number of trials [ 0, 2, 4, ..10]
Loop trials
  Apply the initial_posture to the robot
  For ( attempt = 1 to 5)
    Get visual input as  $x_0$ 
    Feed-forward the connection C1
    Feed-forward the connection C4
    Select one active neuron of PMC with softMax
    If child_mode == 0
      Perform movements
    Else
      Perform movement in mind through the connection C3
    Get visual input as  $x_1$ 
    Compute toy related reward
    If training_mode == 0
      Train the Q-learning # Eq. 7.1
```

**Figure 7.6** Learning algorithm on problem solving (Action sequencing)

### *Dynamic Movement Primitives (DMPs):*

This work applied DMPs framework (Schaal, 2006) to form action primitives/skills for the robots. Action primitives or movements of the robots will be encoded using a set of linear and non-linear dynamic functions. When rolled out, DMPs can generate a series of joint angles that can be used directly to control actuators of a robotic system.

The main application of this framework is to control a movement of a robotic arm which requires smooth arbitrary trajectory. However, in order to use basic DMPs, one need to supply them with a target movement (e.g., a movement recorded from a demonstrator). The basic DMPs use supervised learning to train their parameter sets in order to imitate the target movement. By minimising the error between generated and observed trajectory, the DMPs can reproduce almost the same movement trajectory as the target provided. The benefit of the DMPs framework was not just imitating an

observed movement. follow up work has shown that the shape and the goals parameters of the movement can be changed while in progress which makes the framework well suited to control a robotic arm in an adaptive way (e.g., reaching with obstacle avoidance). Note that shapes and goals parameters in this framework refer to the values in joint space. To set these values while in progress usually requires inverse kinematics solver that calculates joint angles from coordinate values (end point of a robotic arm). Obviously, this technique causes the problem of platform dependency. Two core equations (7.2 and 7.3) and two support functions (7.4 and 7.5) of this framework are given as following:

$$\ddot{y}_t = \alpha_y (\beta_y (g - y_t) - \dot{y}_t) + f_t \quad (7.2)$$

$$f_t(x_t, g) = \frac{\sum_{i=1}^N (\psi_i w_i)}{\sum_{i=1}^N (\psi_i)} x_t (g - y_0) \quad (7.3)$$

$$\psi_i = \exp(-h_i (x - c_i)^2) \quad (7.4)$$

$$\dot{x} = -\alpha_x x \quad (7.5)$$

The first part of Eq. 7.2 represents linear dynamical system (PD) which is perturbed by the forcing term  $f$ . This equation generates trajectory values ( $y_t$ ) which, at any particular point in time, can be used directly to control an actuator. The forcing term  $f$  is responsible for shaping the trajectory. It consists of a number of basis functions ( $\psi$ ) together with their connection weight ( $w$ ). The calculation for this forcing term was done by normalising the weight values and multiply by the canonical value  $x$ , which was decreased to zero over time by the factor  $-\alpha$ , as stated in Eq. 7.5 The basis function (Eq. 7.4) was defined as a Gaussian function. It activates around  $x$  with variance  $h$  and centre  $c$ .

#### *Policy Improvement with Black Box optimization (PI<sup>BB</sup>):*

Unlike a traditional use of the DMPs, there are no observed movements provided in

this work. The system has to find the right move through the processes of trial and error (as inspired by the way infants acquired their motor skills). This work applied the  $PI^{BB}$  algorithm to learn the movement of action primitives. By using the black box optimisation technique (Stulp & Sigaud, 2012),  $PI^{BB}$  does not require any target trajectory to compare; instead, it determines the rewards produced by several samples. Initially, the  $PI^{BB}$  creates a number of sample movements by adding random noises to the current parameter sets (shapes, goals) of a DMPs. A reward assigned to each sample can be calculated arbitrarily depending on tasks' specification. Ideally, each sample will get a different reward. The new parameter sets of the actual control will be calculated by averaging the parameters sets of all sample weighting by their rewards.

$PI^{BB}$ 's algorithm consists of 4 main steps i.e., adding noise, awarding, weighting and averaging. They will be repeated until an outcome is satisfied or reach a maximum step. Initially, the goal parameters of the DMPs (joints' angle) will be assigned using the value of a given smart move, while the shape parameters will be calculated using weight averaging technique borrowed from the basic DMPs. These initial values will be called mean parameter set. After that, all these parameters will be add up with noise terms which, when the DMPs roll out, will cause different movements.

*Adding noise:*

$$M_0 = \text{weightAveraging}(\text{smart move}) \quad \text{initial weights}$$

$$M_{ik} = M_i + N(\mu, \sigma) \quad (7.6)$$

The above equations were used to calculate random noises and add up to the mean parameter set of the shape parameters. Where  $M_0$  is an initial weight vector, which will be used at the first epoch,  $i=0$ ,  $k$  refers to a number of sample which is set to 10.  $N$  is a set of random values generated by a multivariate Gaussian distribution function

with takes mean vector  $\mu$  and covariance matrix  $\sigma$ . This function will be called  $k$  times and add its output vector to the mean parameter,  $M_0$ . This process creates  $k$  sample movements.

*Rewarding:*

The reward  $J_i$  will be given when the preferred interesting event is happened, if the movement caused by DMP can make that event happened then that sample  $i$  will get a reward of 1; otherwise, there will be no reward for that sample, reward = 0.

*Weighting:*

$$P_k = \frac{\exp\left(\frac{-1}{\tau} J_k\right)}{\sum_{k=1}^K \exp\left(\frac{-1}{\tau} J_k\right)} \quad (7.7)$$

where  $P_k$  is a probability value calculated through softmax function assigned to a sample  $k$ . When all sample were rolled out and their rewards were assigned, each sample will be given a probability value which calculated comparing to the summation of all reward (softmax). Calculating a probability value for each sample from the reward it obtained;

*Averaging:*

$$M_{i+1} = \sum_{k=1}^K P_{ik} \mu_{ik} \quad (7.8)$$

This step will calculate the new mean parameters based on weight averaging scheme.

The new mean parameter set was calculated by the averaging all parameter sets weighting with their probability values.

*Applying DMPs+  $PI^{BB}$  to learn action primitives:*

The main idea behind the  $PI^{BB}$  algorithm is that it finds a new set of a policy's parameters by averaging all created samples based on their rewards. By means of weight averaging, the new mean parameters will lead a system to the right direction, approaching a goal. This process will be repeated until the maximum cycle is reached or an action based on the new mean parameters gains enough reward (cause an interesting event).  $PI^{BB}$  algorithm is well suited to learn shape parameters in the DMPs framework. Since the DMPs framework was applied to create actions, the  $PI^{BB}$  was used to refine them. Figure 7.7 illustrated the difference between basic and DMPs+ $PI^{BB}$ . The left part of Figure 7.7 illustrated that basic DMPs learn to imitate observed trajectory by minimising its cost. In contrast, on the right part, goal direct DMPs learn to acquire new motor skill by exploring.

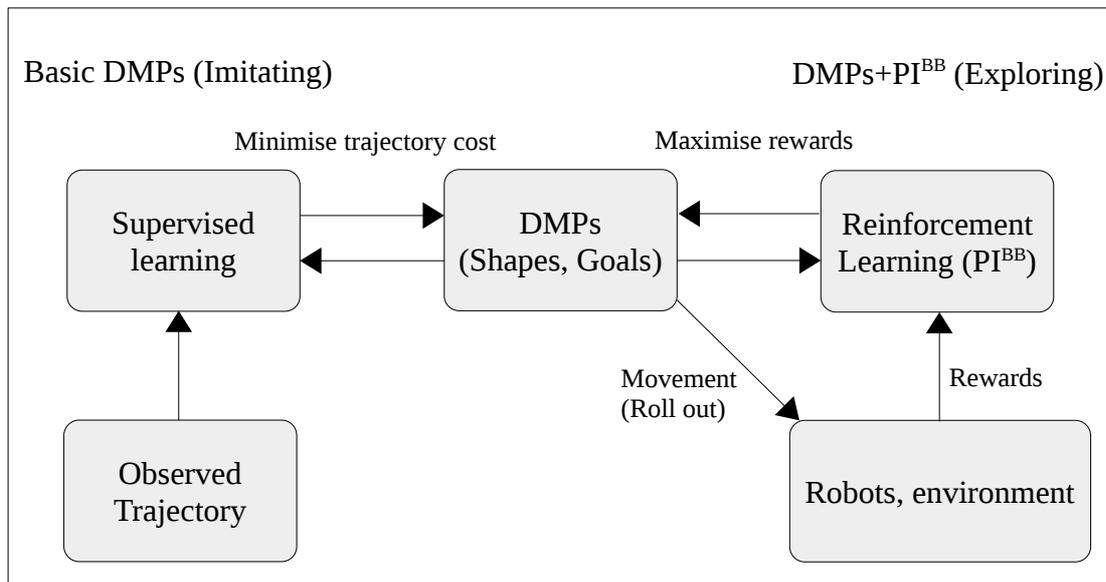

**Figure 7.7** The difference between basic and a reinforcement learning DMPs.

The DMPs was applied to control movements of the iCub simulator, i.e., the right arm. Since the iCub has 7 joints on the right arm to control (excluded the fingers), the DMPs were designed to have 7 goal parameters corresponding to the number of the

joints, and 28 shape parameters (4 for each joint) to modify movement's trajectory of the arm. Each joint can be controlled independently by changing these two parameter sets.

The  $PI^{BB}$  processes will modify all the parameters corresponding to the outcome of the DMP gradually. We propose a scheme that an interesting event leads the system to search for proper parameters of a DMP that can constantly cause that event happened through practice. Therefore, any new intrinsically motivated event will lead the system to the acquisition of a new motor skill. Ideally, after training, each DMP (if assigned) will be able to exhibit one useful movement as a skill. The term 'useful' means that the movement can make one of the interesting events happen. The system can detect 6 events as it was designed to have 10 (6+4) DMPs. The 4 extra DMPs are dedicated to the case whereby only 1 DMP cannot meet the constraint of initial postures. Initially, all DMPs will be assigned with random values to their shape and goal parameters. One DMP will be selected randomly and rolled out to generate series of the joint's values it encoded. At this state, the visual information does not take any effect to the action selection.

Figure 7.8 illustrates two examples of the network connections formed by the system. During the processes of skill acquisition (DMPs+ $PI^{BB}$ ), all robots will encounter all initial tool use situations. Both examples (Figures 7.8a and 7.8b) refer to the robots that acquired all skills. The difference between the two networks is indicated by the different connections between PC and PMC. In addition, activation of the PMC's neurons, as affordance interpretation, should be different, however it is not shown in the figure. The thick arrows refer to the connections which are strengthened by the Q-learning and depending on the initial posture stored in the PC. In the example 1 (Figure 7.8a), during testing, when the robot encounter with initial tool use situation-1 the PMC neuron number 2 will be activated with high activation. This means that the robot will

be more likely to select action-P (due to the selection of the softmax function). Similarly, when the robot sees tool use situation number 4, PMC's neuron number 7 will be active with highest activation, which should lead the system to exhibit action-S. Considering that if the outcome of action-S is similar to the tool use situation 1, the system should exhibit action-P after this which should result in the success of retrieving the toy.

In contrast, if the system is formed as example 2 (Figure 7.8b), it will not be able to succeed in the case of tool far from toy. This is because, in the initial tool use situation 4, PMC's neuron number 5 will be active; however, it was mapped to the action-T which normally not similar to the tool use situation 1. Thus, this system should fail in the test.

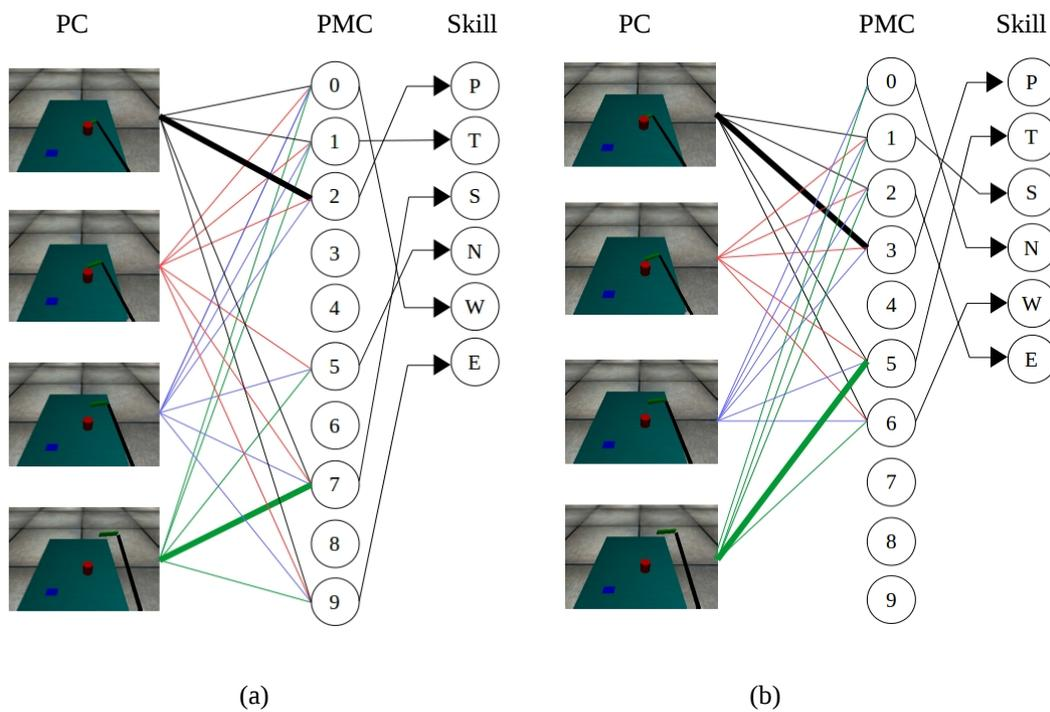

**Figure 7.8** Examples of the network connection of the model after passing through the learning processes. Note that the initial postures (the 4 images on the left) are represented in PC only one at a time. Their images are used for clarification. (a) example 1. (b) example 2

### 7.1.3 Results

According to the two hypotheses on tool use development described earlier, two simulations which are differentiated on two parameters (i.e., the number of IM-detector and the number of training trials) as the age of simulated infants were conducted.

In the first simulation, the number of IM-detectors was varied from 2 to 6 (i.e., 2, 3, 4, 5 and 6) referred to the simulated infant robots aged 14 to 22 months (i.e., 14, 16, 18, 20 and 22). The acquisition of any new motor skill based on interesting events discovered by the robots, thus using a different number of IM-detectors affects the number of motor skills the robots can obtain directly. Note that all robots in this simulation had been initialised with two basic skills, i.e., pulling and touching, and used a fixed number of training trials i.e., 10, in the processes of action sequencing.

In the second simulation, the number of training trials will be varied on the number of IM-detector instead. Using the number of training of 0 and 2 refers to the infants robot aged 14 months, while 4, 6, 8 and 10 refer to the robots aged 16, 18, 20 and 22 months, respectively. Note that infant robots in this simulation are able to detect all interesting events (all IM-detectors are enabled), which means all motor skills can be acquired and exhibited by these robots.

Since DMPs and PIBB underlie the action acquisition processes, this leads to a variation of actions' outcomes in which, for example, two different DMPs that are responsible for the same action will never produce the same movement trajectory and outcome. In other words, each robot can be differentiated by its action repertoire. Therefore, in the same age group, each simulated infant may or may not have suitable actions to solve a given tool use task.

Each infant robot will encounter only one tool use situation (either tool-behind-toy

or tool-far-from-toy) and solves the task using both reactive and planning strategies. The test of each tool use situation of each group will be repeated 30 times; thus, each group consists of 60 individuals (30 repetitions x 2 tool use situations).

Figure 7.9 illustrates the results obtained from the first hypothesis. The top line of the two graphs (Figures 7.9a and 7.9b) indicates the performance of tool use in the situation that the tool located behind the toy. In this case, the performance of tool use of all age groups is similar with high success rate about 90%. The youngest group appears to be able to retrieve the toy at the highest success rate, 100%. This is because they have only two skills in their action repertoire, i.e., pulling and touching, and due to the affordance interpretation, the situation that tool-behind-toy was more likely to cause high activation on the skill-P. Thus, this benefits the first group, and leaves no space for improvement. So, increasing of the number of skills will not result in better performance.

In contrast, the bottom line of both graphs in Figure 7.9 shows the increase in tool use performance when the number of skills is increased. Unlike the situation that tool-behind-toy, skill-P is not suitable to retrieve the toy from the case of large spatial gap, tool-far-from-toy. In the youngest group that only have the skills of pulling and touching, obviously cannot solve the case of large spatial gap. However, it is possible that, sometimes, performing pulling after touching can succeed in this case. Thus, performance of solving the case of tool-far-from-toy starts from about 0% at the youngest group and increases to 10, 40, 45 and 60 corresponding to the increasing of a number of skills.

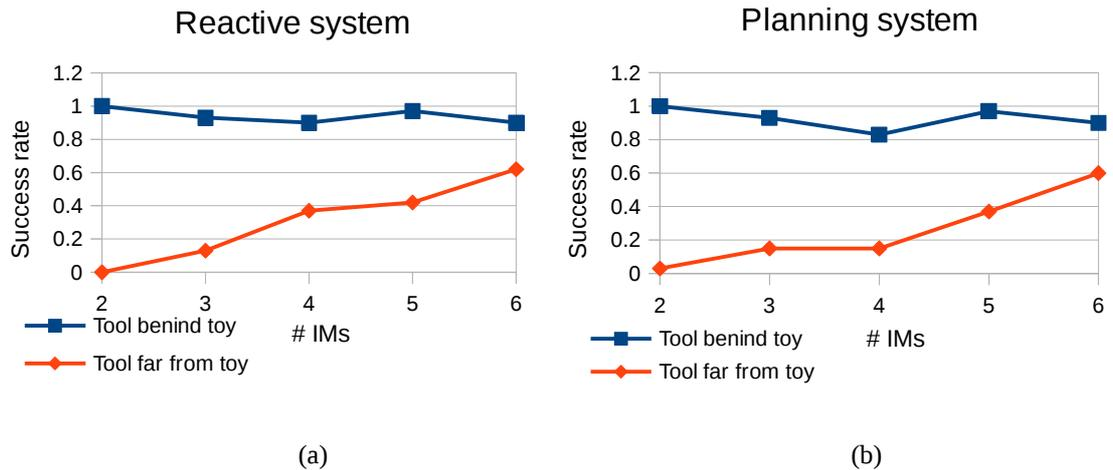

**Figure 7.9** Tool use performance when varying the number of skills. (a) Reactive system. (b) Planning system.

Figure 7.10 shows the results obtained from the second simulation (HP2). In this test, the youngest group, which has no training period, can solve the case of tool-behind-toy at about 60%. In contrast to the first hypothesis, approximately 20% of individuals in this group, of this simulation can have an ability to solve the case of tool-far-from-toy. Although, increasing of the number of training trials results in increasing of the performance in both tests, the performance characteristic is not in a linear fashion. It appears that, in the case of tool-behind-toy, using the number of training trials of 6 results in the highest performance.

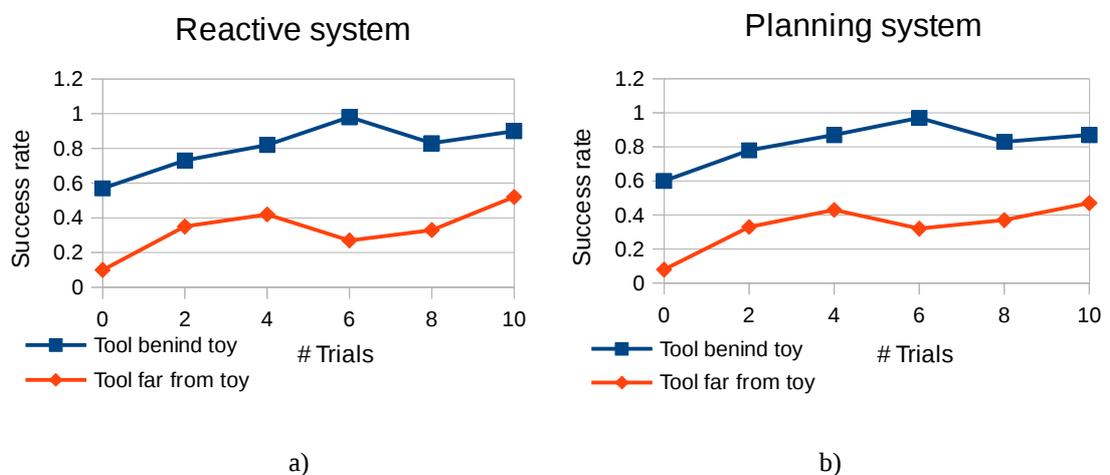

**Figure 7.10** Tool use performance when varying the number of training trials. (a) Reactive system. (b) Planning system.

In both tests, the results obtained by the two systems, reactive and planning, seem identical. This confirms that mental imagery can be used efficiently in replacing the use of overt movements. However, comparing to the infant data reported by Rat-Fischer et al. (2012), the first hypothesis seems to capture the main characteristic of tool use development better than the second. Thus, from these results, we suggest that the development of tool use found in human infants might be caused by differences in the number of motor skills they have mastered.

#### **7.1.4 Discussion**

This study simulates the infants' ages based on two different interpretations on their tool use performance. The first hypothesis interprets the age as a number of acquired motor skills while the latter differentiates the age as a period of experience/practice on tool use scenarios before testing. Even the results reported in the previous section showed a comparable characteristic of tool use performance (qualitatively) as exhibited by our infant robots and the human infants (Rat-Fischer et al., 2012). However, we still lack evidence that addresses a relationship between a number of acquired motor skills or a period of experience and the infants' age. What actually underlie the performance of tool use in human infants is still unknown.

Tool use scenarios, captured through the robot's eye, are varied subject to the movements of the right arm of the robot. However, this does not simply mean that the number of different tool use situations equals the number of action the robot had such as 2 to 6. Because the effect of physical interactions between the tool and the toy is sometimes unpredictable, it is possible that two outcomes caused by the same action can differ from time to time. Therefore, the Q-learning processes accumulate knowledge on solving the tool use task from a variation of inputs, not from a static set.

It is difficult to explain why human infants from the same age group exhibit different performances in their tool use task. We assume that this effect is caused by individual differences whereby the infants grew up in different environments and encounter different situations during their daily lives, which affect the opportunity to discover the means-ends examples of using a tool. Therefore, from the different of sensorimotor learning they have different motor knowledge and might apply different strategies to dealing with a given tool use situation.

Another issue to be discussed in this section regards an uncertainty of actions' outcome whereby it affects the performance of the tool use exhibited by different robots directly. The uncertainty is caused by the visual input that the robot captured (after performing each select/intend action) and used throughout the processes of training and testing. The point is that the outcome (used as neural activation of the PC) can differ when exhibited by the same action. This is according to the effect of physical interactions and that robots are allowed to discover a goal and practice an underlying action themselves. As stated in the learning algorithm (Figure 7.5), the goal parameters used to initiate each DMP is collected through a random movement. It was subject to the chance that the combination of the random values that could make the tool cause an interesting event. Even though the robot was set to stop its movement as soon as the interesting event arises, the effect on the tool toy interaction will rarely be the same. In most cases, they are different.

This work also demonstrates that mental imagery (an expectation of the actions' outcome) can be used to replace overt movements in the acquisition of tool use ability. Since, using mental images allows the robots to do planning to solve the task in mind, this might be interpreted as an understanding of how to use tools. In such cases, the infants can exhibit movements for solving a being perceived tool use scenarios

spontaneously.

To address the issues of the insight of how to use tools and the role of tool use demonstration in future work, new simulations will be conducted which concentrate more on the creation of mental images. In these simulations, the training trials of the connection C3 will be varied subject to the period of time practice, the infants' age, not using a static number of training trials as in the present study. This setting will create a different quality of mental imagery. Infants that spend more time on practice will have clear mental images of the expected actions outcome, while the infants who have little practice will not be able to obtain the clear mental images.

In addition, the fact that demonstration can lead to the spontaneously success in the tool use task will be interpreted as additional training trails to the training of the connection C3. A system that has enough training cycles on this connection (taking from the demonstration session) should have a good quality of mental image which can be used in the processes of self-determined reward.

# Chapter 8

## Conclusion

This chapter summarises the main findings and contributions of all experimental studies conducted throughout the thesis. The details of contribution to knowledge (mentioned in chapter 1) and a list of future work are also provided.

### **8.1 Summary on the Initial Models of Mental Rotation: Experiment 1, 2**

The neurorobotic model proposed in chapter 5 accounts for mental rotation processes based on neural mechanisms involving visual imagery, bottom-up and top-down control, and mental imagery based on inverse and forward models. The model also highlights the importance of motor processes and proprioceptive inputs in the performance of mental rotation tasks. In this respect, the proposed approach agrees with the most recent theoretical and empirical findings on mental rotation (Lamm et al., 2007) and more in general mental simulation (Pezzulo et al., 2010).

Importantly, in addition to replicating the typical mental rotation data, the model is able to account for other data which link overt movements and mental rotations (Wohlschläger & Wohlschläger, 1998; Wohlschläger, 2001). This recent empirical evidence shows that the performance of mental rotation tasks can be improved by the assistance of hand movements, or gestures, called “co-thought gestures” (Chu & Kita, 2008; Chu & Kita, 2011). Spontaneous gestures during the performance of mental rotation provide a rich sensorimotor experience. Following this evidence, the model

includes proprioceptive areas that encode the proprioception resulting from wrist movements. This directly affects the mental rotation processes within the parietal-premotor circuits. On this basis, the model suggests an operational hypothesis on the specific mechanisms through which covert mental rotation processes might rely on overt ones on the basis of forward models.

The model was also validated with the simulated humanoid robot iCub engaged in solving a mental rotation task. This gave further support to the idea that the integration of mental rotation capabilities with affordance and embodied processes is at the basis of the successful performance of the mental rotation tasks. For its embodied nature, the model presented here also sets the basis for investigating the role of co-thought gestures (Chu & Kita, 2008; Chu & Kita, 2011) to support mental rotation tasks, as well as other cognitive capabilities such as the use of communicative gestures and verbal language.

Overall the proposed neurorobotic model provides a useful computational framework to study the integration between mental rotation capabilities and embodied cognition, in particular to demonstrate the role of motor processes and forward models in mental simulation tasks.

## **8.2 Summary on the Generalise Models of Mental Rotation: Experiment 3, 4**

The work on generalisation skills (chapter 6) has presented a novel neuro-robotic model to study the neural mechanisms possibly underlying mental rotation in humans. The model presents some innovations with respect to previous models that further refine the current hypotheses on such mechanisms. First, starting from the approach followed in Caligiore et al. (2010), the model macro-architecture was constrained with knowledge on the areas of brain involved in mental rotation obtained with brain imaging studies

and other neuroscientific studies suggesting the mechanisms operating within them. In this respect, the model was based on a more accurate analysis of the involved brain areas. This led to the isolation of four key brain areas forming the mental rotation system and to propose four hypotheses on the key processes taking place within them. The first two areas involve sensory associative areas. The first area of these, the parieto-occipital cortex, is proposed to perform the mental manipulations of visual representations of objects under the influence of information on possible rotation actions received from motor areas. These processes rely on forward models that allow the anticipation of the rotated image that would result from an actual rotation of a concrete object. The second area, the posterior-parietal cortex, is involved in implementing the mapping between the object images and the corresponding proprioception of the limb possibly holding it (e.g., to compute the wrist orientation corresponding to a certain orientation of the seen objects), and to combine target postures with current postures to decide the next mental rotation to perform. The third and fourth areas involve frontal motor and planning cortex. In particular, the third area, the premotor cortex, implements the preparation of possible rotation movements that are then not executed with limbs but are used to drive internal mentally-imaged rotations. The fourth and last area, the inferior lateral pre-frontal cortex, supervises the whole process by remembering the target object orientation, by monitoring the success/failure of the mental rotation process, and finally by triggering the final response of the system in concert with the premotor cortex.

This architecture and related mechanisms represents an further step with respect to previous computational models (e.g., Sasama et al., 2009; Inui & Ashizawa, 2011) that focused on the mental rotation mechanisms without relating them to the other supporting processes such as the matching processes and the decision making processes

(Lamm et al., 2007). The architecture also represents an innovation with respect to previous neurorobotic models (Seepanomwan et al., 2013a, 2013b) that did not distinguish between the brain areas possibly performing visual and proprioceptive processes, and that also used abstract monitoring and decision making mechanisms.

A second innovation of the model in comparison to other neurorobotic models (Seepanomwan et al., 2013a, 2013b), and shared with other neural-network models (e.g., Sasama et al., 2009), involves a more general rotation process capable of rotating different, possibly novel objects (to the condition that these are represented in terms of edges). This resembles the generalisation capabilities of humans as shown by the classic mental rotation experiments using unusual, novel object images (Hochberg & Gellman, 1977). In this respect, the model has shown that, at least for the type of 2D images used here to test the model, the training set can be formed by very simple images (e.g., sets of dots) as these are sufficient to allow the model to capture the spatial transformations needed to perform mental rotations. The model also indicates that mental rotation of novel objects is easier when these involve few distinctive feature, whereas it might incur in longer reaction times and higher error rates with objects having several matching features while rotated as this causes problems to the matching and decision making processes.

A third innovation of the model with respect to previous models is represented by the mechanism used to monitor the overall mental rotation process and to make the decision about the response to produce. To this purpose, the model incorporated the mutual inhibition model (Usher & McClelland, 2001; Bogacz et al., 2006) that allows a more accurate and biologically-plausible reproduction of the decision making processes of the participants of target psychological experiments. This allowed the model to reproduce the key findings of experiments on mental rotation showing increasing

reaction times and error rates in relation to increasing disparities of the orientation angles of the rotated and the target objects, whereas previous robotic models on mental rotation reproduced less consistent reaction times and could not reproduce error rates (see Seepanomwan et al., 2013a, 2013b).

Last, the embodied nature of the model, tested within a robot, showed the robustness of the model with respect to noise caused by the use of real images and real camera noisy movements. Moreover, it allowed the performance of experiments where the information from the robot proprioception (wrist angle) was added to the mentally simulated proprioception, thus allowing the reproduction, and the proposal of an hypothesis on the possible underlying mechanisms, of psychological experiments where participants perform movements while mentally rotating objects. This led to show that over movements congruent with the performed mental rotation are useful only when mental rotation is difficult due to uncertain images, image-proprioception matching, or other sources of noise. To the best of our knowledge, this represents a prediction of the model. Notice how the model allowed the study of these phenomena as its mental rotation processes are strongly embodied, i.e., they rely on the same mechanisms underlying sensory and motor processes (Clark, 1997; Wilson, 2002; Borghi et al., 2013). This facilitates the integration of mental and sensorimotor processes and information.

Although the model solves technologically rather simple tasks, the fact that it is embodied in a real agent makes it relevant for robotics. Mental rotation can be seen as an instance of planning and as such it could help to improve a robotic performance (Lozano-Perez, 1987; Latombe, 1991; Baldassarre, 2003). Among planning problems, mental rotation is peculiar in that it involves only two possible actions, i.e., clock-wise and anti-clockwise rotations (at least when 2D images are considered). Moreover, the

transformations that it requires are independent of the objects being rotated (the same holds for translations, Terekhov & O'Regan, 2013). As shown with the model, these two features of mental rotation allow the acquisition of general forward models to support planning processes that in principle can work with any type of object and can be based on simplified problems. Moreover, it also allows a mechanism for action selection (i.e., the mechanism deciding where to rotate the object) based on the relation between the rotated object and the target object, similar to cue-based planning strategies (Trullier et al., 1997). In our model, this mechanism relied on the abstraction and integration of information related to the rotated and target objects, processed by encoding their orientations in terms of corresponding wrist proprioception. Mechanisms as simple and general as these might be used to inspire other planning strategies to solve manipulation problems involving a low number of actions, e.g., not only rotations (Ciancio et al., 2015; Meola et al., 2015) but also linear translations in open space and 3D mental rotations.

### **8.3 Summary on Tool Use Development in Infant Robots: Experiment 5**

The experiment conducted in chapter 7 implements tool use competence in humanoid robots based on their ability to see affordances of tool use situations. The performance of using a rake-like tool to retrieve an out-of-reach toy was constrained by two parameters, i.e., a number of motor skills and a number of training trials. The first parameter can be varied assuming as the robots acquire new motor skills gradually. Starting from having a small number, they increase as they are growing up, as assumed. The second parameter refers to the amount of time the robot spent to familiarise with a given tool use task (before testing). This parameter will be changed during the period of problem solving (Q-learning). The two parameters refer roughly to the age of the infant

robots. Obtaining more skills or using more training trials makes the performance of solving the tool use task more efficient. The ability to extract affordance value from a given tool use task is mandatory for the model whereby the affordance was used to indicate which actions are possible to handle as a perceived tool use situation. This allows the system to learn action sequencing within a reasonable period of time and reflect motor knowledge obtained by the system. Different robots would have different sets of motor skills and also different numbers of training trials; thus tool use performance is varied due to the variety of each individual robot.

The interaction between two objects (i.e., a rake-like tool in the robot's hand and a toy on a table) can lead to the acquisition of knowledge of how to use the tool to retrieve the toy. We suggest that knowledge about object interaction are encoded in motor areas in term of affordance interpretation and skills. Selective activation of different motor neurons in response to being a perceive tool use situation (affordances) leads to an execution of different movement (skill). Through the processes of Q-learning, a correct sequence of actions suitable to solve the task can be discovered. In addition, the present model adopts an idea on intrinsic motivations to guide the processes of cognitive acquisition. As mechanisms drive the sensorimotor learning, intrinsic motivations play a key role in the process of skill acquisition which affect the development of tool use directly.

As constrained by the infants' age, the period of time spent during the sensorimotor learning of different infants should differ. Older infants should have more time in the sensorimotor period which results in the acquisition of a number of motor skills. In contrast, young infants should have a smaller number of skills. This number effects tool use performance in a sense that there is more chance that suitable skills for solving a given tool use task consisted of a bigger set than a smaller ones.

Importantly, the two simulations also consider the use of mental imagery in the processes of action sequencing. By replacing the outcome of overt movements with mental images, the robot can accumulate the way to solve a given tool use task in mind. The results confirm that using mental imagery produces similar result to overt movements.

This experiment explains and demonstrates how tool use capability can emerge from sensorimotor processes. Mental imagery and affordances are also possible through sensorimotor learning. Both play a key role in an acquisition of tool use ability. By using the iCub simulator as a synthetic tool, the way knowledge of tools' use in infants developed can be assessed thoroughly.

#### **8.4 Contribution to Knowledge**

This section recalls, and provides more details of the contribution to knowledge stated in the introduction chapter.

- **Scientific understanding of neuro-cortical mechanisms underlying mental rotation.**

Conducting two initial experiments on mental rotation (chapter 5) provided basic knowledge on how to create and manipulate mental images over the neural network model. The model reproduces some mechanisms, possibly performed in the parietal-premotor circuits, implementing the object mental rotation processes and some other mechanisms, possibly performed in prefrontal-premotor circuits, implementing the decision making processes involved in mental rotation (see Zacks, 2008 for more details on the biological mechanisms).

To our knowledge, this model represents the first instance of a neurobotic

model of mental rotation, and a first hypothesis of the brain mechanisms that may underlie this process. The thesis revealed some sort of mental imagery in brain-like mechanisms. The techniques applied in this work are acceptable as biologically plausible mechanisms (i.e., population coding neural networks, Hebbian learning, Kohonen competitive learning and dynamic competition processes). Thus, the thesis also has revealed one possible neural processing technique that might underlie mental rotation processes. To our knowledge, this model represents the first instance of a neuro-robotic model of mental rotation, and a first hypothesis of the brain mechanisms that may underlie this process.

- **Novel bio-constraint neurorobotic frameworks linking motor processes, mental imagery and spatial problem solving.**

The proposed computational framework is in agreement with the most recent theoretical and empirical research on mental rotation (Lamm et al., 2007), including behavioural (Wexler, Kosslyn, & Berthoz, 1998; Wohlschläger, 2001), and with findings on tool use development in human infants (Rat-Fischer et al., 2012). It provides useful mechanisms to study the integration between mental imagery capabilities and embodied cognition and demonstrates the role of motor processes and affordances, in two mental simulation tasks. The framework suggests a specific operational hypothesis on how the information processes taking place in brain sensorimotor areas interplay and form mental imagery capability. This framework first draws an idea from the affordance and forward model view, integrates and specifies them to make them applicable to the explanation of mental rotation and tool use.

- **Novel demonstration of integrating mental imagery capability into a humanoid robotic platform.**

The proposed neurorobotic models were validated with the physical and simulated humanoid robot iCub, engaged in solving mental rotation and tool use tasks. This also provides a demonstration that the integration of mental imagery capabilities with the affordances and embodiment processes (developed in the motor babbling training phase) leads to the acquisition of mental imagery. The results confirmed that mental imagery capability can be obtained and exploited by robots.

In addition, the test with physical robots is relevant not only to facilitate the inclusion in the model of some issues relating to embodied cognition, but also to test the robustness of the model to the variable conditions of the environment and of the robot. For example, the images from the robot camera changed in different trials due to luminance changes within the environment, the variable response of the camera and the accuracy limitations of the camera motors.

- **Novel mechanism permitting an autonomous cognitive acquisition in humanoid robots.**

The work on tool use (chapter 7) adopts an idea of using intrinsic motivations to support the self-generation of goals without the intervention of external agents. The intrinsic motivation system marks as relevant some changes happening in the environment as a consequence of the robot exploratory action. A change marked as relevant then leads the robot to form a goal corresponding to it, meaning that: (a) the world state resulting from the change is stored in the system memory; (b) the robot transiently focusses on that change and this guides a reinforcement learning process that allows the robot to acquire the motor skill that causes the change in a reliable fashion; (c) the representation of the world state becomes able, if activated, to recall the execution of the skill that causes it.

As mechanisms that drive the sensorimotor learning, intrinsic motivations thus play a key role in the process of autonomous skill acquisition which directly affect the development of tool use. In addition, the experiment conducted in chapter 7 also provides an insight of how the fundamental cognitive skills such as affordances, mental imagery and problem solving emerged through the processes of sensorimotor learning.

## **8.5 Future Work**

The future research concerns three important issues which are considered as mandatory for humanoid robots which are not addressed in the present studies.

- **Controlling of the information flow using neural-like mechanism**

In the experimental studies conducted so far, the information flow between the system components is in part managed by non-neural mechanisms. This involves the cyclic flow of information from the sensory/proprioceptive components to the motor components and vice versa e.g., as needed to implement sequences of mental rotation steps. Although this process is commonly used in neural systems to implement planning (e.g., see Butz, Sigaud, & Gérard, 2003; Grush, 2004; Ziemke, Jirnhed, & Hesslow, 2005), it is not biologically plausible, as the information flows are not managed by neural-like mechanisms (Baldassarre, 2003). To our knowledge, how to manage information flow and how to repeat cycles of planning using dynamic neural systems are still a difficult open problem.

To address this issue, the future neurorobotic models will be implemented as a Recurrent Neural Network (RNN) and will adopt particular training techniques

such as reservoir computing/liquid state machine (Lukoševičius & Jaeger, 2009) to train them. These mechanisms could allow RNNs to form connections (flow of information) among neural maps automatically/randomly and only the readout signals will be trained, thus this could permit flexibility/adaptability of the future models.

- **Creating/Manipulating mental images from an uncertainty visual information**

This research issue concerns the use of visual information taken from an uncertainty visual system. Considering that when robots make movements, for example, to do an assigned task, their visual perception will not stay still. The visual input of the present framework, however, was supplied from a static visual system i.e., a fixed camera. Since, the visual input was used directly as a neural activity of neural maps, and also used in the training of the models' connections, thus, it need to be persistent and aligned in a proper position/orientation during training and testing. This limits the performance of the present models to be able to handle only a good form of visual stimuli and familiar situations. The future research will take into account biologically plausible mechanisms that are able of saccading and extracting objects of interest. These mechanisms should capable of autonomously formulating visual information into a good form before passing them to the networks. In addition, neural maps that are used for storing mental images should capable of maintaining the image in more reality manner e.g., in 3 dimensional spaces rather than 2.

- **Mental imagery of their (humanoid robots) body, movements, and effects in the environment**

The third issue considers mental imagery in a more practical domain e.g., mental practice in sports. Human athletes use mental imagery to improve their future performance. By imaging their own movements constraints by intended actions or instructions from a coach, as mental practice, many studies confirmed that the later performance of the athletes can be significantly improved with this practice (Feltz & Landers, 1983; Driskell, Copper, & Moran, 1994). To tackle this issue, a humanoid robot, as a simulated human athlete, has to have a capable of imagine its own body and consequences on the environment, rather than merely focusing on objects. To the best of our knowledge, this research issue is new and fundamentally challenging. Conducting this research could possibly reveal some interesting mechanisms permitting humanoid robots to exploit mental imagery in more complex, useful, scenarios.

Humanoid robots that are going to work with humans and in the human environment will obviously encounter with a variety of situations. Thus, adaptive and developmental capabilities are mandatory features for them. The present studies already addressed some level of cognitive development through the processes of sensorimotor learning, however, they did not capture the case of adaptation. The future work, especially on the use of RNNs and reservoir computing, could offer us more understandings on how to permit humanoid robots to acquire the ability of adaptation.

# References

- Albers, A. M., Kok, P., Toni, I., Dijkerman, H. C., & de Lange, F. P. (2013). Shared representations for working memory and mental imagery in early visual cortex. *Current Biology*, 23(15), 1427-1431.
- Alexander, G. E., DeLong, M. R., & Strick, P. L. (1986). Parallel organization of functionally segregated circuits linking basal ganglia and cortex. *Annual Review of Neuroscience*, 9, 357-381.
- Alnajjar, F., Yamashita, Y., & Tani, J. (2013). The hierarchical and functional connectivity of higher-order cognitive mechanisms: neurorobotic model to investigate the stability and flexibility of working memory. *Front Neurobot*, 7(2).
- Andersen, R. A., & Buneo, C. A. (2002). Intentional maps in posterior parietal cortex. *Annual Review of Neuroscience*, 25, 189–220.
- Anderson, J. R. (1978). Arguments concerning representations for mental imagery. *Psychological Review*, 85(4), 249-277.
- Asada, M., MacDorman, K. F., Ishiguro, H., & Kuniyoshi, Y. (2001). Cognitive developmental robotics as a new paradigm for the design of humanoid robots. *Robotics and Autonomous Systems*, 37(2), 185-193.
- Asada, M., Hosoda, K., Kuniyoshi, Y., Ishiguro, H., Inui, T., Yoshikawa, Y., ... & Yoshida, C. (2009). Cognitive developmental robotics: a survey. *Autonomous Mental Development, IEEE Transactions on*, 1(1), 12-34.
- Azad, P. (2009). *Visual Perception for Manipulation and Imitation in Humanoid Robots* (Vol. 4). Springer Science & Business Media.
- Baldassarre, G. (2001). *Planning with neural networks and reinforcement learning*. University of Essex, Department of Computer Science.
- Baldassarre, G. (2002). A modular neural-network model of the basal ganglia's role in learning and selecting motor behaviours. *Cognitive Systems Research*, 3(1), 5-13.
- Baldassarre, G. (2003). Forward and bidirectional planning based on reinforcement learning and neural networks in a simulated robot. In Butz, M., Sigaud, O., Gérard, P.

- (eds.). *Anticipatory Behavior in Adaptive Learning Systems*. Berlin: Springer, 179-200.
- Baldassarre, G., Caligiore, D., & Mannella, F. (2013). The hierarchical organisation of cortical and basal-ganglia systems: a computationally-informed review and integrated hypothesis. In Baldassarre, G., Mirolli, M. (eds.), *Computational and Robotic Models of the Hierarchical Organization of Behavior* (pp. 237-270). Springer Berlin Heidelberg.
- Baldassarre G., Mannella F., Fiore V. G., Redgrave P., Gurney K., & Mirolli M. (2013) Intrinsically motivated action-outcome learning and goal-based action recall: a system-level bio-constrained computational model. *Neural Networks*, 41, 168-187.
- Barsalou, L. W. (1999). Perceptions of perceptual symbols. *Behavioral and brain sciences*, 22(4), 637-660.
- Barsalou, L. W., Niedenthal, P. M., Barbey, A. K., & Ruppert, J. A. (2003). Social embodiment. *Psychology of Learning and Motivation*, 43, 43-92.
- Barsalou, L. W., Santos, A., Simmons, W. K., & Wilson, C. D. (2008) Language and simulation in conceptual processing. In M. De Vega, A. M. Glenberg, & A. C. Graesser (Eds.), *Symbols, embodiment, and meaning*, Oxford: Oxford University Press, 245-283.
- Barto, A. G., & Sutton, R. (1998). *Reinforcement learning: An introduction*. MIT press.
- Beilock, S. L., & Goldin-Meadow, S. (2010). Gesture changes thought by grounding it in action. *Psychological science*, 21(11), 1605-1610.
- Bemelmans, R., Gelderblom, G. J., Jonker, P., & De Witte, L. (2012). Socially assistive robots in elderly care: A systematic review into effects and effectiveness. *Journal of the American Medical Directors Association*, 13(2), 114-120.
- Bogacz, R., Brown, E., Moehlis, J., Holmes, P., & Cohen, J. D. (2006). The physics of optimal decision making: A formal analysis of models of performance in two-alternative forced-choice tasks. *Psychological Review*, 113(4), 700-765.
- Bogacz, R. (2007). Optimal decision-making theories: Linking neurobiology with behaviour. *Trends in Cognitive Sciences*, 11(3), 118-125.
- Borghia A. M., & Cimatti F. (2010). Embodied cognition and beyond: acting and sensing the body. *Neuropsychologia*, 48(3), 763-773.

- Borghgi, A. M., Scorolli, C., Caligiore, D., Baldassarre, G., & Tummolini, L. (2013). The embodied mind extended: using words as social tools. *Frontiers in Psychology*, 1(4), 214.
- Bouganis, A., & Shanahan, M. (2010, July). Training a spiking neural network to control a 4-dof robotic arm based on spike timing-dependent plasticity. In *Neural Networks (IJCNN), The 2010 International Joint Conference on* (pp. 1-8). IEEE.
- Bourlon, C., Oliviero, B., Wattiez, N., Pouget, P., & Bartolomeo, P. (2011). Visual mental imagery: What the head's eye tells the mind's eye. *Brain research*, 1367, 287-297.
- Braddick, O. J., O'Brien, J. M., Wattam-Bell, J., Atkinson, J., Hartley, T., & Turner, R. (2001). Brain areas sensitive to coherent visual motion. *Perception*, 30(1), 61-72.
- Bremner, P., Pipe, A., Melhuish, C., Fraser, M., & Subramanian, S. (2009). Conversational gestures in human-robot interaction. In *Systems, Man and Cybernetics, 2009. SMC 2009. IEEE International Conference on*, 1645-1649.
- Bridge, H., Harrold, S., Holmes, E. A., Stokes, M., & Kennard, C. (2012). Vivid visual mental imagery in the absence of the primary visual cortex. *Journal of neurology*, 259 (6), 1062-1070.
- Broekens, J., Heerink, M., & Rosendal, H. (2009). Assistive social robots in elderly care: a review. *Gerontechnology*, 8(2), 94-103.
- Brooks, R. A. (1991). Intelligence without representation. *Artificial intelligence*, 47 (1), 139-159.
- Butz, M. V., Sigaud, O., & Gérard, P. (eds.) (2003). *Anticipatory behavior in adaptive learning systems: Foundations, theories, and systems* (Vol. 2684). Berlin: Springer.
- Caligiore, D., Borghi, A. M., Parisi, D., & Baldassarre, G. (2008). Affordances and compatibility effects: A neural-network computational model. In *Connectionist models of behaviour and cognition II: Proceedings of the 11th Neural Computation and Psychology Workshop* (pp. 15-26). Singapore: World Scientific.
- Caligiore, D., Borghi, A. M., Parisi, D., & Baldassarre, G. (2010). TRoPICALS: A computational embodied neuroscience model of compatibility effects. *Psychological Review*, 117, 1188-1228.
- Caligiore, D., Borghi, A., Parisi, D., Ellis, R., Cangelosi, A., & Baldassarre, G. (2013).

- How affordances associated with a distractor object affect compatibility effects: A study with the computational model TRoPICALS. *Psychological Research*, 77(1), 7-19.
- Caligiore, D., Ferrauto, T., Parisi, D., Accornero, N., Capozza, M., & Baldassarre, G. (2008). Using motor babbling and Hebb rules for modeling the development of reaching with obstacles and grasping. In Dillmann, R., Maloney, C., Sandini, G., Asfour, T., Cheng, G., Metta, G., Ude, A. (eds.). *International Conference on Cognitive Systems (CogSys2008)*. E1-8. Karlsruhe, Germany: University of Karlsruhe.
- Caligiore, D., Parisi, D., & Baldassarre, G. (2014). Integrating reinforcement learning, equilibrium points and minimum variance to understand the development of reaching: A computational model. *Psychological Review*, 121, 389-421.
- Caligiore, D., Pezzulo, G., Miall, R. C., & Baldassarre, G. (2013). The contribution of brain sub-cortical loops in the expression and acquisition of action understanding abilities. *Neuroscience & Biobehavioral Reviews*, 37(10), 2504-2515.
- Cangelosi, A., & Riga, T. (2006). An embodied model for sensorimotor grounding and grounding transfer: Experiments with epigenetic robots. *Cognitive science*, 30(4), 673-689.
- Cangelosi, A. (2010). Grounding language in action and perception: from cognitive agents to humanoid robots. *Physics of life reviews*, 7(2), 139-151.
- Cangelosi, A., & Schlesinger, M. (2015). *Developmental robotics*. Boston, MA: MIT press.
- Canny, J. (1986). A computational approach to edge detection. *Pattern Analysis and Machine Intelligence, IEEE Transactions on*, (6), 679-698.
- Carpenter, P. A., Just, M. A., Keller, T. A., Eddy, W., & Thulborn, K. (1999). Graded functional activation in the visuospatial system with the amount of task demand. *Journal of Cognitive Neuroscience*, 11 (1), 9-24.
- Chersi, F., Donnarumma, F., & Pezzulo, G. (2013). Mental imagery in the navigation domain: a computational model of sensory-motor simulation mechanisms. *Adaptive Behavior*, 21(4), 251-262.
- Chu, M., & Kita, S. (2008). Spontaneous gestures during mental rotation tasks: insights

- into the microdevelopment of the motor strategy. *Journal of Experimental Psychology: General*, 137(4), 706–723.
- Chu, M., & Kita, S. (2011). The nature of gestures' beneficial role in spatial problem solving. *Journal of Experimental Psychology: General*, 140(1), 102-116.
- Ciancio, A. L., Zollo, L., Baldassarre, G., Caligiore, D., & Guglielmelli, E. (2013). The Role of Learning and Kinematic Features in Dexterous Manipulation: a Comparative Study with Two Robotic Hands. *International Journal of Advanced Robotic Systems*, 10, e1-21.
- Clark, A. (1997). *Being there: Putting brain, body, and world together again*. Boston, MA: MIT press.
- Cohen, M. S., & Bookheimer, S. Y. (1994). Localization of brain function using magnetic resonance imaging. *Trends Neurosciences*, 17, 268–276.
- Colby, C. L., & Goldberg, M. E. (1999). Space and attention in parietal cortex. *Annual Review of Neuroscience*, 22(1), 319–349.
- Corballis, M. C., & McLaren, R. (1982). Interaction between perceived and imagined rotation. *Journal of Experimental Psychology: Human Perception and Performance*, 8(2), 215.
- de Borst, A. W., Sack, A. T., Jansma, B. M., Esposito, F., De Martino, F., Valente, G., & Formisano, E. (2012). Integration of “what” and “where” in frontal cortex during visual imagery of scenes. *Neuroimage*, 60(1), 47-58.
- Demiris, Y., & Meltzoff, A. (2008). The robot in the crib: a developmental analysis of imitation skills in infants and robots. *Infant and Child Development*, 17(1), 43-53.
- Deneve, S., Latham, P. E., & Pouget, A. (1999). Reading population codes: a neural implementation of ideal observers. *Nature neuroscience*, 2(8), 740-745.
- Di Nuovo, A. G., Marocco, D., Cangelosi, A., De La Cruz, V. M., & Di Nuovo, S. (2012). Mental practice and verbal instructions execution: A cognitive robotics study. The 2012 International Joint Conference on Neural Networks (IJCNN2012).
- Di Nuovo, A. G., Marocco, D., Di Nuovo, S., & Cangelosi, A. (2013). Autonomous learning in humanoid robotics through mental imagery. *Neural Networks*, 41, 147-155.

- Di Nuovo, S., De La Cruz, V., Conti, D., Buono, S., & Di Nuovo, A. (2014). Mental imagery: Rehabilitation through simulation. *Life Span and Disability, 17*, 89-118.
- Dissanayake, M. G., Newman, P., Clark, S., Durrant-Whyte, H. F., & Csorba, M. (2001). A solution to the simultaneous localization and map building (SLAM) problem. *IEEE Transactions on Robotics and Automation, 17*(3), 229-241.
- Dominey, P. F., & Warneken, F. (2011). The basis of shared intentions in human and robot cognition. *New Ideas in Psychology, 29*(3), 260-274.
- D'Mello, S., & Franklin, S. (2011). Computational modeling/cognitive robotics complements functional modeling/experimental psychology. *New Ideas in Psychology, 29*(3), 217-227.
- Doya, K. (2000). Complementary roles of basal ganglia and cerebellum in learning and motor control. *Current Opinion in Neurobiology, 10*(6), 732-739.
- Driskell, J. E., Copper, C., & Moran, A. (1994). Does Mental Practice Enhance Performance? *Journal of Applied Psychology, 79*(4), 481-492.
- Erlhagen, W., & Schöner, G. (2002). Dynamic field theory of movement preparation. *Psychological Review, 109*(3), 545-572.
- Fagg, A. H., & Arbib, M. A. (1998). Modeling parietal-premotor interactions in primate control of grasping. *Neural Networks, 11*(7-8), 1277-1303.
- Farah, M. J. (1984). The neurological basis of mental imagery: A componential analysis. *Cognition, 18*(1-3), 245-272.
- Feltz, D., & Landers, D. (1983). The effects of mental practice on motor skill learning and performance: A meta-analysis. *Journal of Sport Psychology, 5*, 25-57.
- Frick, A., Daum, M. M., Walser, S., & Mast, F. W. (2009). Motor processes in children's mental rotation. *Journal of Cognition and Development, 10*(1-2), 18-40.
- Fukumi, M., Omatu, S., & Nishikawa, Y. (1997). Rotation-invariant neural pattern recognition system estimating a rotation angle. *IEEE Transactions on Neural Networks, 8*(3), 568-581.
- Fukumi, M., Omatu, S., Takeda, F., & Kosaka, T. (1992). Rotation-invariant neural pattern recognition system with application to coin recognition. *IEEE Transactions on Neural Networks, 3*(2), 272-279.

- Funk, M., Brugger, P., & Wilkening, F. (2005). Motor processes in children's imagery: The case of mental rotation of hands. *Developmental Science*, 8(5), 402-408.
- Fuster J.,(2008). *The prefrontal cortex*, Access Online via Elsevier
- Gallese, V., Fadiga, L., Fogassi, L., & Rizzolatti, G. (1996). Action recognition in the premotor cortex. *Brain*, 119(2), 593-609.
- Ganis, G., Thompson, W. L., & Kosslyn, S. M. (2004). Brain areas underlying visual mental imagery and visual perception: an fMRI study. *Cognitive Brain Research*, 20(2), 226-241.
- Ganis, G. (2013). Visual Mental Imagery. In *Multisensory imagery* (pp. 9-28). Springer New York.
- Georgopoulos, A. P., Kalaska, J. F., Caminiti, R., & Massey, J. T. (1982). On the relations between the direction of two-dimensional arm movements and cell discharge in primate motor cortex. *The Journal of Neuroscience*, 2(11), 1527-1537.
- Georgopoulos, A. P., Lurito, J. T, Petrides, M., Schwartz, A. B., & Massey, J.T. (1989). Mental rotation of the neuronal population vector. *Science*, 243, 234-236.
- Gibson, E. J. (1988). Exploratory behavior in the development of perceiving, acting, and the acquiring of knowledge. *Annual review of psychology*, 39(1), 1-42.
- Gibson, E. J., & Pick, A. D. (2000). *An ecological approach to perceptual learning and development*. Oxford University Press.
- Gibson, J. J. (1986). *The ecological approach to visual perception*. Boston, MA: Houghton Mifflin.
- Goldin-Meadow, S. (2005). *Hearing gesture: How our hands help us think*. Cambridge, First Havard University Press.
- Goldin-Meadow, S., & Beilock, S. L. (2010). Action's influence on thought: The case of gesture. *Perspectives on Psychological Science*, 5(6), 664-674.
- Goodale, M. A., & Milner, A. D. (1992). Separate visual pathways for perception and action. *Trends in neurosciences*, 15(1), 20-25.
- Grafton, S. T., Arbib, M. A., Fadiga, L., Rizzolatti, G. (1996). Localization of grasp representations in humans by positron emission tomography: 2. Observation compared with imagination. *Experimental Brain Research*, 112 (2), 103-111.

- Grèzes, J., & Decety, J. (2001). Functional anatomy of execution, mental simulation, observation, and verb generation of actions: A meta-analysis. *Human Brain Mapping, 12*(1), 1-19.
- Grush, R. (2004). The emulation theory of representation: motor control, imagery, and perception. *Behavioral and brain sciences, 27*(3), 377-396.
- Guerin, F., Kruger, N., & Kraft, D. (2013). A survey of the ontogeny of tool use: from sensorimotor experience to planning. *Autonomous Mental Development, IEEE Transactions on, 5*(1), 18-45.
- Hagura, N., Oouchida, Y., Aramaki, Y., Okada, T., Matsumura, M., Sadato, N., & Naito, E. (2009). Visuokinesthetic perception of hand movement is mediated by cerebro-cerebellar interaction between the left cerebellum and right parietal cortex. *Cerebral Cortex, 19*(1), 176-186.
- Harris, I. M., Miniussi, C. (2003). Parietal lobe contribution to mental rotation demonstrated with rTMS. *Journal of Cognitive Neuroscience, 15*, 315-323.
- Herbort, O., Ognibene, D., Butz, M. V., & Baldassarre, G. (2007, July). Learning to select targets within targets in reaching tasks. In *Development and Learning, 2007. ICDL 2007. IEEE 6th International Conference on* (pp. 7-12). IEEE.
- Hochberg, J., and Gellman, L. (1977). The effect of landmark features on mental rotation times. *Memory Cognition, 5*, 23–26.
- Hoffmann, H. (2007). Perception through visuomotor anticipation in a mobile robot. *Neural Networks, 20*(1), 22-33.
- Horn, B. (1986). *Robot vision*. MIT press.
- Hubel, D. H. (1988). *Eye, brain and vision*. New York, NY: Scientific American Books.
- Hubel, D. H., & Wiesel, T. N. (1968). Receptive fields and functional architecture of monkey striate cortex. *The Journal of physiology, 195*(1), 215-243.
- Inui, T., Ashizawa, M. (2011). Temporo-Parietal Network Model for 3D Mental Rotation. In R., Wang, F., Gu (eds.), *Advances in Cognitive Neurodynamics (II)* (pp. 91-95): Springer Netherlands.
- Jeannerod, M., Arbib, M. A., Rizzolatti, G., & Sakata, H. (1995). Grasping objects: The cortical mechanisms of visuomotor transformation. *Trends in Neurosciences, 18*(7),

314–320.

- Johnston, S., Leek, E. C., Atherton, C., Thacker, N., Jackson, A. (2004). Functional contribution of medial premotor cortex to visuo-spatial transformation in humans. *Neuroscience Letters*, 355, 209–212.
- Kail, R., Pellegrino, J., & Carter, P. (1980). Developmental changes in mental rotation. *Journal of Experimental Child Psychology*, 29(1), 102-116.
- Kaiser, A., Schenck, W., & Möller, R. (2010, April). Mental imagery in artificial agents. In *Workshop new challenges in neural computation* (pp. 25-32).
- Kaplan, F. (2008). Neurorobotics: an experimental science of embodiment. *Frontiers in neuroscience*, 2(1), 22-23.
- Kahrs, B. A., Jung, W. P., & Lockman, J. J. (2013). Motor origins of tool use. *Child development*, 84(3), 810-816.
- Kahrs, B. A., & Lockman, J. J. (2014). Building tool use from object manipulation: A perception–action perspective. *Ecological Psychology*, 26(1-2), 88-97.
- Khatib, O. (1986). Real-Time Obstacle Avoidance for Manipulators and Mobile Robots. *The International Journal of Robotics Research*, 5(1), 90-98.
- Kohonen, T. (1990). The self-organizing map. *Proceedings of the IEEE*, 78(9), 1464-1480.
- Kohonen, T. (2001). *Self-organizing maps*. Berlin: Springer (Third Edition).
- Kosslyn, S. M. (1980). *Image and mind*. Harvard University Press.
- Kosslyn, S. M. (1996). *Image and the Brain. The Resolution of the Imagery Debate*. Cambridge, MA: MIT Press.
- Kosslyn, S. M., Thompson, W. L., & Ganis, G. (2006). *The case for mental imagery*. Oxford University Press.
- Krakauer, J. W., & Mazzoni, P. (2011). Human sensorimotor learning: adaptation, skill, and beyond. *Current opinion in neurobiology*, 21(4), 636-644.
- Krichmar, J. L. (2012). Design principles for biologically inspired cognitive robotics. *Biologically Inspired Cognitive Architectures*, 1, 73-81.
- Krüger, M., & Krist, H. (2009). Imagery and motor processes—When are they connected? the mental rotation of body parts in development. *Journal of Cognition*

- and Development*, 10(4), 239-261.
- Kulkarni, A., Yap, A. C., & Byars, P. (1990). *Neural networks for invariant object recognition*. Proceedings of the 1990 Symposium on Applied Computing.
- Lamm, C., Fischmeister, F. P. S., & Bauer, H. (2005). Individual differences in brain activity during visuo-spatial processing assessed by slow cortical potentials and LORETA. *Cognitive Brain Research*, 25(3), 900-912.
- Lamm, C., Windischberger, C., Moser, E., Bauer, H. (2007). The functional role of the dorso-lateral premotor cortex during mental rotation An event-related fMRI study separating cognitive processing steps using a novel task paradigm. *NeuroImage*, 36(4), 1374-1386.
- Latombe, J.-C. (1991). *Robot Motion Planning*. The Springer International Series in Engineering and Computer Science. 124 Berlin: Springer.
- Lockman, J. J. (2000). A perception-action perspective on tool use development. *Child development*, 137-144.
- Logan, G. (1996). The CODE theory of visual attention: An integration of space-based and object-based attention. *Psychological Review*, 103, 603–649.
- Lozano-Perez, T. (1987). A simple motion-planning algorithm for general robot manipulators. *IEEE Journal of Robotics and Automation*, 3(3), 224-238.
- Lukoševičius, M., & Jaeger, H. (2009). Reservoir computing approaches to recurrent neural network training. *Computer Science Review*, 3(3), 127-149.
- Lungarella, M., Metta, G., Pfeifer, R., & Sandini, G. (2003). Developmental robotics: a survey. *Connection Science*, 15(4), 151-190.
- Mannella, F., Gurney, K., Baldassarre, G. (2013). The nucleus accumbens as a nexus between values and goals in goal-directed behavior: a review and a new hypothesis. *Frontiers in Behavioral Neuroscience*, 7, e1-29.
- Masehian, E., Sedighzadeh, D. (2007). Classic and heuristic approaches in robot motion planning - A chronological review. *World Academy of Science, Engineering and Technology*, 29(1), 101-106.
- McCarty, M. E., Clifton, R. K., & Collard, R. R. (2001). The beginnings of tool use by

- infants and toddlers. *Infancy*, 2(2), 233-256.
- Miall, R. C. (2003). Connecting mirror neurons and forward models. *Neuroreport*, 14(17), 2135-2137.
- Meltzoff, A. N. (1995). Understanding the intentions of others: Re-enactment of intended acts by 18-month-old children. *Developmental psychology*, 31(5), 838-850.
- Meltzoff, A. N. (2007). The 'like me' framework for recognizing and becoming an intentional agent. *Acta Psychologica*, 124, 26-43.
- Meola, V. C., Caligiore, D., Sperati, V., Zollo, L., Ciancio, A. L., Taffoni, F., Guglielmelli, E., Baldassarre, G. (2015). Development of discrete and rhythmic manipulation skills: a policy-search reinforcement-learning robot model. *IEEE Transactions on Autonomous Mental Development*. In press.
- Metta, G., Sandini, G., Vernon, D., Natale, L., & Nori, F. (2008). The iCub humanoid robot: an open platform for research in embodied cognition. *Proceedings of the 8th workshop on performance metrics for intelligent systems*.
- Meyer, J.-A. & Filliat, D. (2003). Map-based navigation in mobile robots - II. A review of map-learning and path-planning strategies. *Cognitive Systems Research*, 4(4), 283-317.
- Michelon, P., Vettel, J. M., Zacks, J. M. (2006). Lateral somatotopic organization during imagined and prepared movements. *Journal of Neurophysiology*, 95, 811-822.
- Middleton, F. A., Strick, P. L. (2000). Basal ganglia and cerebellar loops: motor and cognitive circuits. *Brain Research Reviews*, 31(2-3), 236-250.
- Mirolli, M., & Parisi, D. (2011). Towards a Vygotskyan cognitive robotics: the role of language as a cognitive tool. *New Ideas in Psychology*, 29, 298-311.
- Mohan, V., Morasso, P., Metta, G., & Kasderidis, S. (2011). Actions and imagined actions in cognitive robots. In *Perception-Action Cycle* (pp. 539-572). Springer New York.
- Möhring, W., & Frick, A. (2013). Touching Up Mental Rotation: Effects of Manual Experience on 6-Month-Old Infants' Mental Object Rotation. *Child development*, 84(5), 1554-1565.
- Morse, A. F., Belpaeme, T., Cangelosi, A., & Smith, L. B. (2010). Thinking with your

- body: Modelling spatial biases in categorization using a real humanoid robot. In *Proc. of 2010 annual meeting of the Cognitive Science Society. Portland, USA* (pp. 1362-1368).
- Moro, V., Berlucchi, G., Lerch, J., Tomaiuolo, F., & Aglioti, S. M. (2008). Selective deficit of mental visual imagery with intact primary visual cortex and visual perception. *cortex*, *44*(2), 109-118.
- Munakata, Y., & Pfaffly, J. (2004). Hebbian learning and development. *Developmental Science*, *7*(2), 141-148.
- Nishimoto, R., & Tani, J. (2009). Development of hierarchical structures for actions and motor imagery: a constructivist view from synthetic neuro-robotics study. *Psychological Research PRPF*, *73*(4), 545-558.
- Ognibene, D., Baldassare, G. (2015). Ecological active vision: four bio-inspired principles to integrate bottom-up and adaptive top-down attention tested with a simple camera-arm robot. *IEEE Transactions on Autonomous Mental Development*, *7*(1), 3-25.
- Ognibene, D., Rega, A., & Baldassarre, G. (2006). A model of reaching that integrates reinforcement learning and population encoding of postures. In *From Animals to Animats 9* (pp. 381-393). Springer Berlin Heidelberg.
- Oja, E. (1982). Simplified neuron model as a principal component analyzer. *Journal of mathematical biology*, *15*(3), 267-273.
- Oudeyer, P.-Y., & Kaplan, F. (2007). What is Intrinsic Motivation? A Typology of Computational Approaches. *Frontiers in Neurorobotics*, *1*(6), 1-14.
- Paivio, A. (1969). Mental imagery in associative learning and memory. *Psychological review*, *76*(3), 241.
- Pannebakker, M. M., Jolicœur, P., Van Dam, W. O., Band, G. P. H., Richard Ridderinkhof, K., & Hommel, B. (2011). Mental rotation impairs attention shifting and short-term memory encoding: Neurophysiological evidence against the response-selection bottleneck model of dual-task performance. *Neuropsychologia*, *49*(11), 2985-2993.
- Pearson, D. G., Deepröse, C., Wallace-Hadrill, S. M., Heyes, S. B., & Holmes, E. A. (2013). Assessing mental imagery in clinical psychology: A review of imagery

- measures and a guiding framework. *Clinical Psychology Review*, 33(1), 1-23.
- Pecher, D., & Zwaan, R. A. (Eds.). (2005). *Grounding cognition: The role of perception and action in memory, language, and thinking*. Cambridge University Press.
- Peniak, M., Marocco, D., Tani, J., Yamashita, Y., Fischer, K., & Cangelosi, A. (2011). Multiple time scales recurrent neural network for complex action acquisition. *Proceedings of ICDL-Epirob*.
- Perlovsky, L. I. (2011). Mirror neurons, language, and embodied cognition. In *Computational Intelligence, Cognitive Algorithms, Mind, and Brain (CCMB)*, 2011 IEEE Symposium on, 1-7.
- Pezzulo, G., Barca, L., Bocconi, A. L., & Borghi, A. M. (2010). When affordances climb into your mind: Advantages of motor simulation in a memory task performed by novice and expert rock climbers. *Brain and Cognition*, 73(1), 68-73.
- Pezzulo, G., Barsalou, L. W., Cangelosi, A., Fischer, M., McRae, K., & Spivey, M. (2011). The mechanics of embodiment: a dialogue on embodiment and computational modeling. *Frontiers in Cognition*, 2 (5), 1–21.
- Pfeifer, R., & Bongard, J. (2006). *How the body shapes the way we think: a new view of intelligence*. MIT press.
- Pfeifer, R., & Gomez, G. (2005). Interacting with the real world: design principles for intelligent systems. *Artificial life and Robotics*, 9(1), 1-6.
- Piaget, J. (1952). *The origins of intelligence in children* (Vol. 8, No. 5, p. 18). New York: International Universities Press.
- Pouget, A., Dayan, P., & Zemel, R. (2000). Information processing with population codes. *Nature Reviews Neuroscience*, 1(2), 125-132.
- Pouget, A., Dayan, P., & Zemel, R. S. (2003). Inference and computation with population codes. *Annual Review of Neuroscience*, 26(1), 381-410.
- Pouget, A., Sejnowski, T. J. (1997). Spatial transformations in the parietal cortex using basis functions. *Journal of Cognitive Neuroscience*, 9(2), 222-237.
- Purves, D., Cabeza, R., Huettel, S. A., Platt, M. L., & Brannon, E. M. (2013). *Principles of cognitive neuroscience*. Sunderland, MA: Sinauer Associates.
- Pylyshyn, Z. W. (1973). What the mind's eye tells the mind's brain: A critique of mental

- imagery. *Psychological bulletin*, 80(1), 1.
- Rahimi, M., & Karwowski, W. (1992). *Human-robot interaction*. Taylor & Francis, Inc..
- Rat-Fischer, L., O'Regan, J. K., & Fagard, J. (2012). The emergence of tool use during the second year of life. *Journal of experimental child psychology*, 113(3), 440-446.
- Richter, W., Somorjai, R., Summers, R., Jarmasz, M., Menon, R.S., Gati, J.S. Georgopoulos, A. P., Tageler, C. Ugurbil, K., Kim, S.-G. (2000). Motor area activity during mental rotation studied by time-resolved single-trial fMRI. *Journal of Cognitive Neuroscience*, 12(2), 310-320.
- Riek, L. D., Rabinowitch, T. C., Bremner, P., Pipe, A. G., Fraser, M., & Robinson, P. (2010). Cooperative gestures: Effective signaling for humanoid robots. In *Human-Robot Interaction (HRI), 2010 5th ACM/IEEE International Conference on* (pp. 61-68). IEEE.
- Rizzolatti, G., Craighero, L. (2004). The mirror-neuron system. *Annual Review Neuroscience*, 27, 169-192.
- Rizzolatti, G., Luppino, G., Matelli, M. (1998). The organization of the cortical motor system: new concepts. *Electroencephalography and clinical neurophysiology*, 106, 283-296.
- Rodda, M., & Grove, C. (2013). *Language, cognition, and deafness*. Psychology Press.
- Roelfsema, P. R.; Lamme, V. A., & Spekreijse, H. (1998). Object-based attention in the primary visual cortex of the macaque monkey. *Nature*, 395, 376–381.
- Rowley, H., Baluja, S., & Kanade, T. (1998). Neural network-based face detection. *Pattern Analysis and Machine Intelligence, IEEE Transactions on*, 20(1), 23-38.
- Roy, D., Hsiao, K. Y., & Mavridis, N. (2004). Mental imagery for a conversational robot. *Systems, Man, and Cybernetics, Part B: Cybernetics, IEEE Transactions on*, 34(3), 1374-1383.
- Ryan, R. M., & Deci, E. L. (2000). Self-determination theory and the facilitation of intrinsic motivation, social development, and well-being. *American Psychologist*, 55(1), 68-78.
- Sadeghipour, A., & Kopp, S. (2012). Gesture processing as grounded motor cognition:

- Towards a computational model. *Procedia-Social and Behavioral Sciences*, 32, 213-223.
- Saegusa, R., Natale, L., Metta, G., & Sandini, G. (2011, July). Active perception for action mirroring. In *Neural Networks (IJCNN), The 2011 International Joint Conference on* (pp. 2865-2872). IEEE.
- Salinas, E., Abbott, L. (1996). A model of multiplicative neural responses in parietal cortex. *Proceedings of the national academy of sciences*, 93(21), 11956-11961.
- Sandini, G., Metta, G., Vernon, D. (2007). The icub cognitive humanoid robot: An open-system research platform for enactive cognition. In *50 years of artificial intelligence* (pp. 358-369). Springer Berlin Heidelberg.
- Sasama, T., Mitsumoto, H., Yoneda, K., & Tamura, S. (2009). *Mental Rotation by Neural Network. Fifth International Conference on Intelligent Information Hiding and Multimedia Signal Processing (IIH-MSP2009)*.
- Schaal, S. (1999). Is imitation learning the route to humanoid robots?. *Trends in cognitive sciences*, 3(6), 233-242.
- Schaal, S. (2006). Dynamic movement primitives-a framework for motor control in humans and humanoid robotics. In *Adaptive Motion of Animals and Machines*(pp. 261-280). Springer Tokyo.
- Schillaci, G., Hafner, V. V., & Lara, B. (2012, March). Coupled inverse-forward models for action execution leading to tool-use in a humanoid robot. In *Proceedings of the seventh annual ACM/IEEE international conference on Human-Robot Interaction* (pp. 231-232). ACM.
- Schlesinger, M., & Langer, J. (1999). Infants' developing expectations of possible and impossible tool-use events between ages 8 and 12 months. *Developmental Science*, 2(2), 195-205.
- Schlesinger, M. (2013). Investigating the origins of intrinsic motivation in human infants. In *Intrinsically motivated learning in natural and artificial systems* (pp. 367-392). Springer Berlin Heidelberg.
- Seepanomwan, K., Caligiore, D., Baldassarre, G., & Cangelosi, A. (2013a). A cognitive robotic model of mental rotation. In *Computational Intelligence, Cognitive Algorithms, Mind, and Brain (CCMB), 2013 IEEE Symposium on* (pp. 36-43). IEEE.

- Seepanomwan, K., Caligiore, D., Baldassarre, G., Cangelosi, A. (2013b). Modelling mental rotation in cognitive robots. *Adaptive Behavior*, 21(4), 299-312.
- Shepard, R., Metzler, J. (1971). Mental rotation of three dimensional objects. *Science*, 171(972):701-3.
- Shepard, R. N., & Cooper, L. A. (1982). *Mental images and their transformations*. The MIT Press.
- Siegwart, R., Nourbakhsh, I. R., & Scaramuzza, D. (2011). *Introduction to autonomous mobile robots*. MIT press.
- Smith, L. B., & Samuelson, L. (2010). Objects in space and mind: from reaching to words. *Thinking Through Space: Spatial Foundations of Language and Cognition*.
- Snyder, L. H., Grieve, K. L., Brotchie, P., & Andersen, R. A. (1998). Separate body- and world-referenced representations of visual space in parietal cortex. *Nature*, 394, 887–891.
- Stephan, K. M., Fink, G. R., Passingham, R. E., Silbersweig, D., Ceballos-Baumann, A. O., Frith, C. D., & Frackowiak, R. S. (1995). Functional anatomy of the mental representation of upper extremity movements in healthy subjects. *Journal of neurophysiology*, 73(1), 373-386.
- Stoytchev, A. (2005, April). Behavior-grounded representation of tool affordances. In *Robotics and Automation, 2005. ICRA 2005. Proceedings of the 2005 IEEE International Conference on* (pp. 3060-3065). IEEE.
- Stulp, F., & Sigaud, O. (2012). Policy improvement methods: Between black-box optimization and episodic reinforcement learning.
- Terekhov, A. V., & O'Regan, J. K. (2013). Space as an invention of biological organisms. *arXiv preprint arXiv:1308.2124*.
- Tikhanoff, V., Cangelosi, A., Fitzpatrick, P., Metta, G., Natale, L., Nori, F. (2008). An open-source simulator for cognitive robotics research: the prototype of the iCub humanoid robot simulator. *Proceedings of the 8th workshop on performance metrics for intelligent systems*.
- Tikhanoff, V., Cangelosi, A., & Metta, G. (2011). Integration of speech and action in humanoid robots: iCub simulation experiments. *Autonomous Mental Development, IEEE Transactions on*, 3(1), 17-29.

- Tikhanoff, V., Pattacini, U., Natale, L., & Metta, G. (2013, October). Exploring affordances and tool use on the iCub. In *Humanoid Robots (Humanoids), 2013 13th IEEE-RAS International Conference on* (pp. 130-137). IEEE.
- Thill, S., Caligiore, D., Borghi, A. M., Ziemke, T., & Baldassarre, G. (2013). Theories and computational models of affordance and mirror systems: An integrative review. *Neuroscience and Biobehavioral Reviews*, *37*(3), 491-521.
- Trafton, J. G., Schultz, A. C., Perznowski, D., Bugajska, M. D., Adams, W., Cassimatis, N. L., & Brock, D. P. (2006a). Children and robots learning to play hide and seek. In *Proceedings of the 1st ACM SIGCHI/SIGART conference on Human-robot interaction* (pp. 242-249). ACM.
- Trafton, J. G., Trickett, S. B., Stitzlein, C. A., Saner, L., Schunn, C. D., & Kirschenbaum, S. S. (2006b). The relationship between spatial transformations and iconic gestures. *Spatial Cognition and Computation*, *6*(1), 1-29.
- Trullier, O., Wiener, S. I., Berthoz, A., Meyer, J.-A. (1997). Biologically based artificial navigation systems: review and prospects. *Progress in Neurobiology*, *51*(5), 483-544.
- Tsagarakis, N. G., Li, Z., Saglia, J., & Caldwell, D. G. (2011, May). The design of the lower body of the compliant humanoid robot “cCub”. In *Robotics and Automation (ICRA), 2011 IEEE International Conference on* (pp. 2035-2040). IEEE.
- Tucker, M., & Ellis, R. (2001). The potentiation of grasp types during visual object categorization. *Visual Cognition*, *8*, 769–800.
- Tucker, M., & Ellis, R. (2004). Action priming by briefly presented objects. *Acta Psychologica*, *116*, 185–203.
- Usher, M., McClelland, J. L. (2001). On the time course of perceptual choice: The leaky competing accumulator model. *Psychological Review*, *108*, 550-592.
- Vernon, D. (1991). Automated Visual Inspection and Robot Vision. In *Machine vision*. Prentice Hall.
- Watkins, C. J., & Dayan, P. (1992). Q-learning. *Machine learning*, *8*(3-4), 279-292.
- Weng, J. (2004). Developmental robotics: Theory and experiments. *International Journal of Humanoid Robotics*, *1*(2), 199-236.
- Wexler, M., Kosslyn, S.M., & Berthoz, A. (1998). Motor processes in mental rotation.

- Cognition*, 68(1), 77-94.
- Whiteson, S., Taylor, M. E., & Stone, P. (2007). Empirical studies in action selection with reinforcement learning. *Adaptive Behavior*, 15(1), 33-50.
- Wilson, F. R. (1998). *The hand: How its use shapes the brain, language, and human culture*. New York: Pantheon Books.
- Wilson, M. (2002). Six views of embodied cognition. *Psychonomic Bulletin and Review*, 9(4), 625-636.
- Wohlschläger, A. (2001). Mental object rotation and the planning of hand movements. *Perception & Psychophysics*, 63(4), 709-718.
- Wohlschläger, A., & Wohlschläger, A. (1998). Mental and manual rotation. *Journal of Experimental Psychology: Human Perception and Performance*, 24(2), 397-412.
- Wolpert, D. M., Ghahramani, Z., & Jordan, M. I. (1995). An internal model for sensorimotor integration. *Science*, 269(5232), 1880.
- Wolpert, D. M., & Kawato, M. (1998). Multiple paired forward and inverse models for motor control. *Neural Networks*, 11(7-8), 1317-1329.
- Wolpert, D. M., Diedrichsen, J., & Flanagan, J. R. (2011). Principles of sensorimotor learning. *Nature Reviews Neuroscience*, 12(12), 739-751.
- Yarbus, A. L., Haigh, B., Riggs, L.A. (1967). *Eye movements and vision* (Vol. 2, No. 5.10). New York: Plenum press.
- Yamashita, Y., & Tani, J. (2008). Emergence of functional hierarchy in a multiple timescale neural network model: a humanoid robot experiment. *PLoS Comput Biol*, 4(11).
- Zacks, J. (2008). Neuroimaging studies of mental rotation: a meta-analysis and review. *Journal of Cognitive Neuroscience*, 20(1), 1-19.
- Ziemke, T., Jirnhed, D., & Hesslow, G. (2005). Internal simulation of perception: A minimal neuro-robotic model. *Neurocomputing: An International Journal*, 68, 85-104.
- Zvyagintsev, M., Clemens, B., Chechko, N., Mathiak, K. A., Sack, A. T., & Mathiak, K. (2013). Brain networks underlying mental imagery of auditory and visual information. *European Journal of Neuroscience*, 37(9), 1421-1434.