

2023

# The Agency of Error in Post-digital Print

Rosser, Laura

<https://pearl.plymouth.ac.uk/handle/10026.1/20672>

---

<http://dx.doi.org/10.24382/5015>

University of Plymouth

---

*All content in PEARL is protected by copyright law. Author manuscripts are made available in accordance with publisher policies. Please cite only the published version using the details provided on the item record or document. In the absence of an open licence (e.g. Creative Commons), permissions for further reuse of content should be sought from the publisher or author.*



**UNIVERSITY OF  
PLYMOUTH**

**THE AGENCY OF ERROR IN POST-DIGITAL PRINT**

by

**LAURA ROSSER**

A thesis submitted to the University of Plymouth

in partial fulfilment for the degree of

**DOCTOR OF PHILOSOPHY**

School of Art, Design and Architecture

**January 2023**

PhD Thesis

# The Agency of Error in Post-Digital Print

The Agency of Error in Post-Digital Print

PhD Thesis Laura Rosser 2022

Laura Rosser

The University of Plymouth  
The School of Art, Design and Architecture

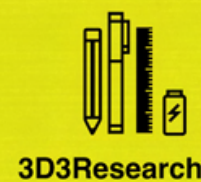

## Copyright Statement

This copy of the thesis has been supplied on condition that anyone who consults it is understood to recognise that its copyright rests with its author and that no quotation from the thesis and no information or images derived from it may be published without the author's prior consent.

## Acknowledgements

I would like to express my deepest appreciation to my supervisors for their invaluable advice, continuous support, and patience during my PhD studies. I am extremely grateful to Andrew Prior for his insight, positive outlook, and, importantly, for helping me to get me over the line. Likewise, the completion of my PhD would not have been possible without the immense knowledge, experience, and nurturing offered by Geoff Cox, to whom I am deeply indebted. I would also like to extend my heartfelt gratitude to Sarah Bodman for her consistent support and faith in me and my project, and for helping me to *keep it real* and stay focused on the expanded field of printmaking which is very important to me. Lastly, Jane Grant for her creativity and invaluable encouragement in the formative stages of the project.

I would like to recognise the assistance, research training, and financial help that I received from the University of Plymouth and my funders: the 3d3 Centre for Doctoral Training and the Arts and Humanities Research Council. This support was instrumental in enabling me to study for a doctorate, and I gratefully acknowledge the guidance of the 3d3 network and my 3d3 peers who played an important role especially in the formative part of the PhD.

Particularly helpful to me were Carmen Wong and Aida Bahrami, who diligently helped with proofreading. I also had the great pleasure of working with the designers at Work Form on the User Guide and Tom O'Reilly who offered his binding expertise. I'd like to acknowledge the assistance of Neo Print Studios in Bolton for the Neo Print Residency Award, and their financial and practical help in screen printing my work and endless diagrams. I must include in my thanks Phil Brice, *The Reader*, for his patience and the quality of his performances. I'd also like to recognise the help that I received from Pawel Mendrek at Academy of Fine Arts in Katowice in hosting my residency and accompanying show on the *Agency of Error* at StrefArt Gallery in Tychy, Poland. Especially helpful to me during this time was Agata Cukierska, the curator at Kronika Centre for Contemporary Art in Bytom, Poland.

Colleagues from the University of Plymouth who supported me include Mary Costello, the exhibition co-ordinator at the Arts Institute at the University, who helped me display my work. I am extremely grateful to 'Inky' Paul Collier for providing me with encouragement throughout the duration of this project. I also had the great opportunity of working with the University of Plymouth's Fine Art students on several projects which became fun and full of laughter thanks to their involvement.

I am also grateful to my PhD peers who are now soon to be life-long fellow doctors. What will we talk about now, I wonder... Maybe something like how to get over the PhD-induced coffee addiction?

Lastly, I am deeply indebted to my wonderful family: to my husband Joe for providing unstinting technical support and advice, and for his impressive patience and acceptance of the loss of years of social life; to my father Peter for his patience, his encouragement, and his wise words; to my mother Ann who never wavered in her support, especially at those points where I felt overwhelmed by it all. Thank you!

## Author's Signed Declaration

At no time during the registration for the degree of Doctor of Philosophy has the author been registered for any other University award without prior agreement of the Doctoral College Quality Sub-Committee.

This thesis has been proofread by a third party; no factual changes or additions or amendments to the argument were made as a result of this process. A copy of the thesis prior to proofreading will be made available to the examiners upon request.

Work submitted for this research degree at the University of Plymouth has not formed part of any other degree either at the University of Plymouth or at another establishment.

This study was financed with the aid of a studentship from the 3d3 Centre for Doctoral Training and the Arts and Humanities Research Council (AHRC). The following external institutions were visited for research purposes: Bolton University; Academy of Fine Arts in Katowice, Poland. Publications: *Parallax Forum*, 2018-2021; *Hackers and Designers Network Imaginaries*, 2021. Public Presentation of creative research outputs: StrefArt Gallery in Tychy, Poland,



2018; Kronika Centre for Contemporary Art in Bytom, Poland, 2019; Arts  
Institute at the University of Plymouth, 2021. Presentations at conferences:  
IMPACT 10 multidisciplinary printmaking conference, 2020; Society for Artistic  
Research (SAR10\*) conference on artistic research, 2020.

Word count of main body of thesis: 48066

Signed: *V. Rossef.*  
Date: 8<sup>th</sup> January 2023.

## Abstract

Laura Rosser

### The Agency of Error in Post-digital Print

This research investigates the tensions between different interpretations of error: from binary and digital evaluations to the more abstract and human ways we approach and think about error. My interest comes from a meshing together of these tendencies and the slippages between various modes of interpretation. Consequently, in my artistic practice error exists as both activity and subject matter, and the projects expose relationality rather than define discrete types of error.

This approach goes against common understandings of error in digital culture, where systems try to reduce, if not erase, error. Equally in relation to printmaking practices, error is often understood only in terms of visual anomalies to be avoided through improvements to the printing process – whereas the problem is that there is a concern with error in print practices and culture, and yet a failure to address it critically. In this respect, error is encapsulated by Gilles Deleuze's phrase 'misadventures of thought' (1994, p.148), which distinguishes error as a form of wandering and implies a state of

unknowing. This expanded sense of error has the potential to open up new lines of thinking, in that not knowing upholds new beginnings and artistic potential.

My research is not just about error in the ontological sense of the word, but about error in the context of a particular set of creative practices and concepts including printmaking, ideas of the post-digital, and how these allow for an emphasis on what I refer to as the *relational agency of error*. In his elaboration of the post-digital, the theorist Florian Cramer suggests that artists favour the misbehaviour of *failing* analogue and digital technologies (2014, p.20). I apply this theory to the expanded field of printmaking where errors created using analogue and digital print equipment co-exist as creative tools in artistic practice. Indeed, how is error in printmaking understood differently as a consequence of post-digital practices, and cultures? Artistic practice in post-digital printmaking takes issue with the crude distinction between digital and analogue creative processes, and instead reveals how new and old technologies intertwine in 'a space of creative action' (Geary and Catanese, 2012, p.8). This places emphasis on relationality rather than predetermined or unified processes.

From a post-digital perspective, and departing from information theory (Shannon and Weaver, 1948), errors and technologies begin to develop their own voices. In my research, I have found that rational thought starts to break down when error occurs – a useful discovery in terms of undermining pre-determined logic and intentionality. Drawing additionally on actor–network theory (Latour), new materialism (Barad and Bennett) and the power of cognitive nonconscious (Hayles), I consider error to be an active agent in the printmaking process, where any notion of the artist’s intention is part of a wider network of relations. Hence, my contribution to knowledge is to propose that error cannot be autonomous and is only active as part of a larger relational web of agency, or a *co-constituted agency*, distinct from a commonplace understanding where things or matter can exist independently (Harman, 2011a, p. 177). In addition to my artistic practice that forms part of this research and engages with different forms of error, I use diagramming to explore these entangled relations, and to highlight the importance that is ascribed to relationality in understanding error. In this sense, my written thesis and artistic practice can be described as attempts to diagram the concept of error.

## Table of Contents

List of Figures.....	15
Introduction .....	25
<i>User Guide</i> .....	25
<i>Main discussion</i> .....	26
The User Guide .....	33
PART ONE .....	73
Chapter 1: Introduction to Error .....	74
1.0 <i>What is an error?</i> .....	75
1.1 <i>History of printmaking and its expanded field</i> .....	84
1.2 <i>Post-digital printmaking</i> .....	98
1.3 <i>Printed matter matters</i> .....	123
Chapter 2: Mechanisms of Research.....	134
2.0 <i>Methodological framework</i> .....	134
2.1 <i>Diagramming relations</i> .....	136
Chapter 3: Survey of the Field .....	141
3.1 <i>Error and artistic practice</i> .....	142

3.2 <i>The field of post-digital print</i> .....	147
3.3 <i>The diagram as a post-digital device</i> .....	163
3.4 <i>The art of instruction</i> .....	170
<b>Summary of Part One</b> .....	<b>177</b>
<b>PART TWO</b> .....	<b>179</b>
<b>Chapter 4: Error in Post-Digital Print</b> .....	<b>181</b>
4.1 <i>Post-digitality</i> .....	181
4.2 <i>Print persists under post-digital conditions</i> .....	206
4.3 <i>Beyond digital logics</i> .....	212
<b>Chapter 5: Error as Misadventure</b> .....	<b>221</b>
5.1 <i>Misadventures of thought</i> .....	221
5.2 <i>Deviating from rationality</i> .....	233
5.3 <i>Not knowing as artistic enquiry</i> .....	249
<b>Summary of Part Two</b> .....	<b>262</b>
<b>PART THREE</b> .....	<b>263</b>
<b>Chapter 6: Errors-in-Action</b> .....	<b>266</b>

6.1 <i>The post-digital is no longer the domain of the human</i> .....	267
6.2 <i>The liveliness of error</i> .....	272
6.3 <i>The (im)materiality of error</i> .....	283
6.4 <i>Print errors are resistant to automation</i> .....	291
<b>Chapter 7: Relationality</b> .....	<b>297</b>
7.1 <i>The potentiality of the agentive network</i> .....	298
7.2 <i>Co-constituted agency</i> .....	304
7.3 <i>Becoming error</i> .....	315
7.4 <i>The liveness of error</i> .....	319
7.5 <i>Error enacts contingency</i> .....	322
<b>Chapter 8: Error in Post-Digital Print</b> .....	<b>329</b>
8.1 <i>Error opens up imaginative potential</i> .....	330
8.2 <i>Error exposes misadventures of thought</i> .....	333
8.3 <i>Error demonstrates a co-constituted form of agency</i> .....	336
8.4 <i>Contingency becomes the unbounded condition of error</i> .....	339
8.5 <i>Openings</i> .....	340
<b>Afterword</b> .....	<b>343</b>

List of Sources.....	347
<b>APPENDICES .....</b>	<b>373</b>
<i>Table of Contents.....</i>	373
<i>Meta Diagramming Project: un-Learning Space: Diagrammatic</i>	
<i>Misadventures .....</i>	374
<i>Error as a site of breakdown and renewal: Can social media can be used to</i> <i>promote a society’s new mode of living, labour and community? .....</i>	388
<i>Re-imagined Futures .....</i>	400
<i>The un-Learning Zone .....</i>	403
<i>Plymouth Whispers.....</i>	407
<i>Copycopycopy (Romano).....</i>	410
<i>Speak and [mis]Spell .....</i>	412
<i>30-Minute Typo.....</i>	414
<i>Social Making Minutes .....</i>	415
<i>Type ‘n’ Tweet.....</i>	417



## List of Figures

Figure 1: <i>Engpass at Aussendienst</i> (Signer, 2000), accident sculptures. Image: © Roman Signer. ....	78
Figure 2: <i>Error 520</i> (Lefterov, 2014). This screenprint was the first result that came up when I was searching for keywords printmaking and error on Google. Image: © Saatchi. ....	79
Figure 3: <i>Model of Communication</i> (Shannon and Weaver, 1948, p. 381). Diagram capturing the transmission of information. ....	81
Figure 4: <i>Enriched Bread</i> (Kent, 1965), screenprint created using hand cut stencils. Image: © Estate of Corita Kent. ....	84
Figure 5: <i>Error</i> (Rosser, 2018). Detail of a hand-rendered diagram, exhibited at Prawo Serri: The Agency of Error, StrefArt Gallery, Tychy, Poland.....	86
Figure 6: <i>No one knows where I am</i> (Rosser, 2015). Slide created from typewritten texts produced for a project (no.1 of 50 slides).....	87
Figure 7: <i>Diamond Sūtra</i> (868CE). Detail of relief printed Buddhist sutras. ....	88
Figure 8: <i>The Caxton Celebration – William Caxton showing specimens of his printing to King Edward IV and his Queen</i> (Small, 1877). ....	90
Figure 9: Rosalind Krauss’s diagram of the expanded field (1979, p. 37). ....	94
Figure 10: <i>Printmaking in the Expanded Field</i> (Pettersson, 2015, p. 278–279), is an adaptation of Rosalind Krauss’s diagram of the Expanded Field. ....	95

Figure 11: <i>Vernacular of File Formats</i> (Menkman, 2009–2010). One of a series of digital glitch experiments. Image: © Rosa Menkman.....	99
Figure 12: <i>You're not a real hipster – until you take your typewriter to the park</i> (2013). A meme Florian Cramer refers to in his 2014 text. ....	101
Figure 13: <i>LetterMpress</i> (Bonadies Creative Inc., 2017). Screenshot of a virtual letterpress environment app.....	109
Figure 14: <i>Route 66</i> (2019). Screenshot of a filter mimicking silkscreen colour separations with offset layers, using a filter by Mister Retro: Genuine Quality. Original (left), edited (right). ....	111
Figure 15: Example of an analogue film effect added to a photograph using the app, <i>Huji Cam</i> (Manhole Inc., 2019). Screenshot taken from App store. .	112
Figure 16: <i>Dream: Pletikosa</i> (Poskovic, 2017). Hand printed from laser-cut woodblocks. Image: © Endi Poskovic.....	120
Figure 17: <i>A Machine Dialogue</i> (Rosser, 2018). A diagram exploring the relationship between error and print technologies. ....	133
Figure 18: <i>Mechanisms of Research</i> (Rosser, 2021–2). See folded diagram overleaf. ....	134
Figure 19: <i>Error</i> (Rosser, 2018). A 6m x 2.5m diagram exhibited at <i>Prawo Serri: The Agency of Error</i> , TrefArt Gallery, Tychy, Poland.....	137

Figure 20: <i>Agency of Error</i> diagramming performance exploring research mechanisms, during a residency at Academy of Fine Arts in Katowice, Poland (Rosser, 2018).....	138
Figure 21: Sequence of images from <i>Agency of Error</i> diagramming performance at Academy of Fine Arts in Katowice, Poland (Rosser, 2018)....	139
Figure 22: <i>Triple Noun Stratagem</i> , (Barham, 2013), biro drawing on paper. Image: © Anna Barham. ....	142
Figure 23: Film still from <i>Johan and Francois</i> (Augustijnen, 2001–2003). Image: © Jan Mot. ....	145
Figure 24: <i>Materials of Resistance</i> (Thornton, 2018). Exhibition catalogue, Plymouth Art Centre. Image: © Plymouth Art Centre. ....	146
Figure 25: <i>Printing at Home</i> (Antin, 2010). Image: © Xavier Antin.....	150
Figure 26: <i>Just in Time, or a Short History of Production</i> (Antin, 2010a). Image: © Xavier Antin.....	152
Figure 27: <i>Each and Every Command</i> (Callanan, 2016). Image: © Martin John Callanan. ....	155
Figure 28: <i>Post Hoc</i> (Mitchell, 2019a). Aotearoa New Zealand National Pavilion at Venice. Biennale, 2019. Image: © Dane Mitchell. ....	157
Figure 29: <i>AA to ZZ</i> (Bigland, 2019). Image: © Guy Bigland.....	160
Figure 30: <i>AAA to ZZZ</i> (Bigland, 2018). Image: © Guy Bigland. ....	161
Figure 31: <i>A Benedictionary</i> (Phillips, 2011). Image: © Benedict Phillips.....	162

Figure 32: *No. 82*, a publication by Pist Protta celebrating errors in print.  
Image: © Space Poetry publishing. .... 162

Figure 33: *Diagramming Art's Institutional Global Playgrounds* (Ambrožič, 2019) at a research workshop, University of Plymouth. .... 166

Figure 34: *SURVIVOR (F)/Mystical Apocalypse* (Treister, 2016–2019). Image: © Suzanne Treister. .... 167

Figure 35: Hand-drawn diagram *As We May Think* (Berry, 2010). Image: courtesy of the artist. © David Berry..... 168

Figure 36: *Aesthetical-Rational-Logical Diagram* (Kenning, 2020), produced during a live drawing project. Image: © Dean Kenning. .... 168

Figure 37: *de-leb* (Clarke, 2012), a collaborative project led by Ami Clarke of *Banner Repeater*. Image: © Ami Clarke. .... 169

Figure 38: Written instructions on *How to Make a Dadaist Poem* (Tzara, 1920).  
..... 172

Figure 39: *Jupiter Proposals* (Liversidge, 2008–2009). A typewritten proposal submitted to the Jupiter Artland gallery. Image: © Jupiter Artland..... 175

Figure 40: *Jupiter Proposals* (Liversidge, 2008–2009). Installation view. Image: © Jupiter Artland. .... 176

Figure 41: Laser cut woodcut print (Rosser, 2018). Image based on distortion of a CRT monitor..... 183

Figure 42: <i>We Ain't all Middle Class Bohemians</i> (Rosser, 2015), hand cut woodcut. ....	185
Figure 43: Detail of woodcut experiment (Rosser, 2018). ....	186
Figure 44: <i>Enchiridion: Machine Washing Your Ligature</i> (Rosser, 2019), detail of dot matrix printed instruction guide. ....	188
Figure 45: <i>Enchiridion: Unlearning Space</i> (Rosser, 2021), large instructional printed panels welcome the audience to the exhibition at Arts Institute, University of Plymouth. ....	189
Figure 46: <i>Enchiridion</i> (Rosser, 2018), detail from installation of misprinted instruction sets, University of Plymouth. ....	190
Figure 47: Screenshots taken by me while scraping data from wikiHow articles to collect and manipulate data for errant instruction sets. ....	191
Figure 48: <i>Auto-Incorrect</i> (Rosser, 2017). A socially engaged project connecting typists, typewriter, laptop, and dot matrix printer. ....	194
Figure 49: <i>Enchiridion</i> (Rosser, 2021). Instruction sets hand-set in type and printed as a series of interactive pamphlets. ....	196
Figure 50: A dot matrix printer is set up alongside an etching press in my print studio. ....	200
Figure 51: A gaggle of second-hand dot matrix printers purchased for the PhD project. ....	201

Figure 52: *Newspaper Extinction Timeline* (2011). An illustration predicting when printed newspapers will become obsolete (2019 in the UK). Image: © Alessandro Ludovico..... 206

Figure 53: The Reader recites the instructional script aloud and with conviction for *Reading Enchiridion*, 2019. .... 225

Figure 54: *How to (un)Fold Paper* (Rosser, 2018). Extract from The Reader’s script. .... 236

Figure 55: *Topology of Error* (Rosser, 2018). An early diagram exploring the relations between error types. .... 241

Figure 56: *Error as Misadventure* (Rosser, 2021). A Venn diagram from my sketchbook..... 260

Figure 57: *[mis]Feeds #1* (Rosser, 2019). Entangled printed paper feed, printers, and Arduino. Image: courtesy of Marcin Wysocki. .... 270

Figure 58: *[mis]Feeds #3* (Rosser, 2021). Installation of printers, each programmed to carry out a specific task. Image: courtesy of Helge Mruck... 276

Figure 59: *[mis]Feeds #1* (Rosser, 2019). The printers’ fraught activity interrupts the space. Image: courtesy of Barbara Kubska..... 279

Figure 60: Visitors to the exhibition *Sex, Suicide, Socialism, Spirit and Stereotypes* at Kronika Centre for Contemporary Art use social media to send a tweet to the printers as part of *[mis]Feeds #1* (Rosser, 2019)..... 281

Figure 61: *[mis]Feeds #3* (Rosser, 2021). Fifteen printers connected by paper and Raspberry Pis. Image: courtesy of Helge Mruck. .... 282

Figure 62: Misalignment on the printers in *[mis]Feeds #3* (Rosser, 2021). .... 287

Figure 63: Printer ribbon tears due to fraught activity during an experiment in my studio. .... 290

Figure 64: Early five- and eight-hole punched computer tape (Coles, 2010). 292

Figure 65: *The Digital Iceberg* (Berry, 2015b, p. 47). © David Berry..... 300

Figure 66: *[mis]Folding* (Rosser, 2021). Documentation of attempts at folding a diagram in response to the reading of errant instructions on how to fold a map. Image: courtesy of Helge Mruck..... 302

Figure 67: Attempts at folding-unfolding-misfolding a series of screenprinted diagrams during a residency at Bolton University (Rosser, 2018). .... 303

Figure 68: My experiment in creating *perfect* folds which reveal misaligned information that form new relationships. Detail of fold. .... 307

Figure 69: Screenprinting the edition of 50 diagrams at Neo Print Studios, Bolton (Rosser, 2018). .... 325

Figure 70: *[mis]Folding* (Rosser, 2021). Detail of folded paper, which eventually breaks down. Image: courtesy of Helge Mruck. .... 326

Figure 71: Installation of *[mis]Folding* (Rosser, 2021), at the Arts Institute of the University of Plymouth. It exposes the intersect between error, print, and the artist's actions. Image: courtesy of Helge Mruck. .... 328

Figure 72: Detail of a diagram exploring how the exhibition space became a diagrammatic space, a flow of ideas and lines of thought (Rosser, 2021). .....	344
Figure 73: <i>Network Imaginaries. Re-imagined Futures: wikiHow, Hackers &amp; Designers</i> (2021, pp. 196–197). .....	401
Figure 74: <i>Network Imaginaries. Re-imagined Futures: wikiHow, Hackers &amp; Designers</i> (2021, pp. 202–203). .....	402
Figure 75: <i>Network Imaginaries. Re-imagined Futures: wikiHow, Hackers &amp; Designers</i> (2021, pp. 204–205). .....	402
Figure 76: <i>The un-Learning Zone</i> (Rosser, 2019). Detail of front cover blanks. ....	404
Figure 77: <i>The un-Learning Zone</i> (Rosser, 2019). Details of participants at BABE at Arnolfini. ....	405
Figure 78: <i>The un-Learning Zone</i> (Rosser, 2019). Details of participants at BABE at Arnolfini. ....	405
Figure 79: <i>The un-Learning Zone</i> (Rosser, 2019). Portable print laboratory, including battery-powered printer and finishing equipment. ....	406
Figure 80: <i>Plymouth Whispers</i> at Plymouth Art Weekender (Rosser, 2018). Detail of participants from Instagram. ....	408
Figure 81: <i>Plymouth Whispers</i> at Plymouth Art Weekender (Rosser, 2018). Detail of participants from Instagram. ....	408



Figure 82: <i>Plymouth Whispers</i> at Plymouth Art Weekender (Rosser, 2018).	
Detail of participants.....	409
Figure 83: <i>Plymouth Whispers</i> at Plymouth Art Weekender (Rosser, 2018).	
Detail of whispering participants. ....	409
Figure 84: <i>Copycopycopy</i> (Romano), 2018. Video still.....	410
Figure 85: <i>Copycopycopy</i> (Romano) (Rosser, 2018). Video still. ....	411
Figure 86: <i>Speak and [mis]Spell</i> (Rosser, 2018). Video still. ....	412
Figure 87: <i>Speak and [mis]Spell</i> (Rosser, 2018). Video still. ....	413
Figure 88: <i>30-Minute Typo</i> (Rosser, 2018). Screenshot of poster advertising the workshop. ....	414
Figure 89: <i>Social Making Minutes</i> (Rosser, 2018), at Take A Part: Social Making symposium, Guildhall, Plymouth. ....	415
Figure 90: <i>Social Making Minutes</i> (Rosser, 2018), at Take A Part: Social Making symposium, Guildhall, Plymouth. ....	416
Figure 91: <i>Type 'n' Tweet</i> (Rosser, 2018). Port Elliot Literature Festive, Cornwall.....	418
Figure 92: <i>Type 'n' Tweet</i> (Rosser, 2018). Port Elliot Literature Festive, Cornwall.....	418
Figure 93: <i>Type 'n' Tweet</i> (Rosser, 2018). Port Elliot Literature Festive, Cornwall.....	419
Figure 94: <i>Type 'n' Tweet</i> (Rosser, 2018). Detail of Twitter feeds. ....	420

Figure 95: *Type 'n' Tweet* (Rosser, 2018). Details of individual Tweets..... 421

## **Introduction**

This thesis, like any written document, is structured in a linear manner, with the practice placed at the foreground. The logic of this mimics the systematic nature of my artistic practice, and yet remains open to misadventure in keeping with the central argument. The main discussion is intersected with diagrams which somewhat break away from linearity and bridge my academic discourse and artistic thinking and experiences. The various elements of my research are outlined in what follows.

## **User Guide**

In the final submission, the User Guide will be submitted as a separate printed document. My intention is that it is to be read first, to foreground the practice and as a preface to the main discussion. For simplicity in this digital submission, it is condensed as one document.

The User Guide provides a narrative account of the set of projects that are central to this artistic research. The guide contains four project descriptions and a series of images that document various encounters with the work and exhibitions during the PhD registration period.

The project descriptions sit somewhere outside or, rather, on the edges, of the academic discussion. These accounts provide explanatory details on the projects, in parallel to the main discussion in the thesis and a set of diagrams that offer an alternative entry into the research. The idea here is that the projects are largely left to articulate their contribution to the research on their own terms.

### **Main discussion**

The thesis is divided into three main parts, each shaping a particular cluster of ideas. Although each part can be read independently, this is not my intention as they are designed to be read sequentially. In this way, each part sets a specific group of ideas in motion and, like a diagram, it 'moves things on' (O'Sullivan, 2016, p. 14), building the argument and creating a narrative arc across the thesis as a whole.

Part One lays the foundation for my research project and the main discussion that follows in Parts Two and Three. This opening section introduces the conceptual, practical and structural framework of my thesis. It outlines the approaches and systems of research on error, which contribute to the unfolding of my argument in the primary discussion. Part One consists of: an

introduction to the concept of error and the overall research project (Chapter 1); a diagram mapping my mechanisms of research, and a discussion defining how diagramming forms part of my methodology (Chapter 2); and a review of what other artists and theorists are thinking and doing in the field of post-digital print and diagramming (Chapter 3).

Part Two consists of Chapters 4 and 5 which outline how errors traverse the apparent dualisms of analogue and digital, human and machine. It seeks to address how error can be used to set up relations between things which are entangled and not a representation of distinct categories. Although Chapter 4 broadly leans towards the nonhuman, and Chapter 5 towards the human, this is not meant to be exclusive, and they have been separated pragmatically for readability, although clearly they are more entangled than the structure suggests.

Two projects, *Enchiridion* and *Reading: Enchiridion*, are aligned with Chapters 4 and 5 respectively. Through these projects and substantive discussion, I investigate the tensions between different interpretations of error: from the binary and strictly digital forms to the more abstract and human ways we approach and think about error. Consequently, I explore how pursuing a

human-centred ontology is no longer adequate when speaking about the digital world, which prompts the discussion on the nonhuman in Part Three.

Multiple claims in relation to the research project are established in Part Two. Chapter 4 argues how error in post-digital print opens up imaginative potential. Although this is an argument that all my projects make, and a claim which spans throughout the thesis, the substantive discussion on the post-digital takes place in this chapter. Chapter 5 outlines my claim that error signifies a space of unknown potentiality. These are the leading arguments of the thesis, and I return to them throughout the main discussion. Together these chapters provide an account of how logical thought starts to break down when errors occur, and I express this through artistic means of exploring territories beyond the boundaries of intentionality and knowing. This sets forth my claim that error should be upgraded to an uncertain and complex space of not knowing, unlearning, and renewal.

Part Three contains Chapters 6 and 7 and the Conclusion in Chapter 8.

Broadly, it reveals how the relationship between artist, printed things, and error calls agency into question. Here I uncover how agency, like error, cannot be defined in terms of a simplistic binary opposition. This claim is analysed in Chapter 6, which builds on my discussion of the post-digital and error as

material things. It becomes clear how technology and other nonhuman assemblages begin to take on their own forms of agency. In Chapter 7, I further develop the concerns outlined in the preceding chapter, advancing how error indicates a relational form of agency.

Part Three looks closely at the agency of error in parallel with my projects *[mis]Feeds* (in Chapter 6), where the ability of technology and other nonhuman assemblages to exhibit agency is examined, and *[mis]Folding* (in Chapter 7), which investigates error's relationships with culture, society, and matter.

The narrative arc crests in this third and final part of the thesis, with the following claims substantiating the materiality of error. Chapter 6 explores how the post-digital challenges ideas of what is considered to be material or immaterial. The chapter argues that error is an active agent in the printmaking process, and the artist and their intentionality are part of a wider network of relations. Subsequently, Chapter 7 examines the emergence of a network of complex relations. This last chapter forms the apex of my argument, claiming how error cannot be autonomous and is only active as part of a larger relational form of agency, which I refer to as *co-constituted agency*.

The thesis concludes with the argument that error exists as both practice and subject matter, and that my projects enact contingency rather than any discrete type of error, beyond binary or digital interpretations, or mere mistake. The conclusion thus recapitulates the set of core concepts introduced in Chapter 1, providing a synopsis of my research and importantly identifying possible directions for future work. This summary also draws on the provocations encountered in the early stages of the PhD project and the research questions I outline below.

1. How do the different scales at which error operates in relation to printmaking affect my decisions as an artist? It is important to recognise that errors occur at different scales, some of which I try to prevent and others I embrace – this is part of the process of being a printmaker. At what point do we make the decision to accept or reject error?  
Furthermore, taking into account the agency of the artist, what authority or power do we have to make such decisions?
2. With the post-digital in mind, how does the set of projects reveal error's ability to disrupt logic and produce knowledge? How does error's capacity to disrupt and resist digital logic and rational thought correlate with the formal definitions of error?



3. What are the political and cultural implications of reimagining error as capable of a relational form of agency and only becoming tangible or materially present when in relation to other constituents? What relationship does error have with things/beings/objects/humans? Since my research addresses relationality, and error is somewhat incorporeal in and of itself, how is it registered in art practice – what does it look and feel like?

These questions stress the problems I have encountered in my practice and will address in this thesis – shaping the impact of my PhD. My contribution to new knowledge is that error is not capable of autonomy, and is activated as part of a larger relational network. The research thus demonstrates that there is a need for better evidence of the relational agency of error in print practice and culture.

And finally, the Appendices provide details on other related projects and writing that sit outside of the PhD submission, but that have contributed to its formation. This serves the added purpose of bookending the main discussion with practice (also see User Guide). In addition to a set of sub-projects, the Appendices contain a Meta-Diagramming text that provides insight into my

diagrammatic thinking and practice which has significantly contributed to unpicking, albeit complicating, ideas around post-digital print error. This is also introduced below as one of my organisational *mechanisms*. This text is followed by a paper that was written in conjunction with my practice outside of the PhD, which is a response to my short residency and exhibition at Kronika Centre for Contemporary Art, Bytom, Poland.

A User Guide

# Agency of Error in Post-digital Print

Laura Rosser



## Agency of Error in Post-digital Print

At the centre of this research is my artistic practice, which concentrates on creative use of error within the context of post-digital printmaking. My practice connects me to the errors themselves, by working with an intermix of analogue and digital print technologies, exhibitions and workshops. Simultaneous reading and artistic practice enable me to unpick the nuances of my enquiry, and it is the intermix of these modes that inform my research project.

Through four print-based artistic projects and the written thesis I explore the relations inherent to the print apparatus (including screen-print, letterpress, typewriters, dot matrix and laser printers) and how this elicits unpredictable outcomes. This exposes artistic practice to the creative opportunities of error. My interest lies in how print's strength (in its ability to reproduce) is also its weakness (due to inherent flaws and uncertainties).<sup>1</sup> By producing multiple copies errant characteristics are enhanced by speed, surface, repetition and quantity, becoming increasingly *errored* with each print. The set of projects have been re-worked and exhibited in multiple spaces, including exhibitions, book fairs and conferences. My contribution is to highlight these relations in creative practice. Therefore it is fundamental that I encounter print errors first hand, rather than basing my research entirely on secondary sources or theory alone.

A key element of sharing the projects, has been for error to occur live in the space, rather than as a form of documentation. Experiencing the practice gives direct access to, what I refer to as *errors-in-action*, a phrase that I take from artist-writer Emma Cocker (2016). This operates in a similar way to how the writer Estelle Barrett discusses practice as research, 'as the production of knowledge or philosophy *in action*' (2007, p. 1). Meeting error in this way, where it happens live, allows the errors to speak (2007, p. 22) and to be part of the production of new knowledge. This gives access to error that is less determined and

more unknown. As Barrett, writes, it is 'the materiality of materials, materialised in the act of invention, [which] assumes an ethical role in human affairs' (2007, p. 20). Barrett's position is suggestive of the material structure to error in this research practice, and error's construction is interwoven with artistic enquiry, printmaking's processes, and ideas of the post-digital. Error's inner fabric thus consists of a synthesis of these relations. This material structure is a key concept which is activated by encountering error in artistic practice. In doing so, error provides a seductive means of going astray, drawing me and other artists towards more unexpected and unpredictable outcomes. In artistic practices there has been a lot of attention to error for these reasons, and this research is situated in this tradition. Within this framework, strategies such as repetition, reproduction, translation, and duration are central to my thinking. Accordingly, I seek out those practices which incorporate errant approaches which promote disruption, irrationality, uncertainty. Expressed otherwise, error provides me with potential to go awry. As such, rather than to assume errors are paths to follow in a linear fashion, they are multiplicitous and slippery to define. Across the following set of projects the relationship between error, print technologies, reveal that error is not simply one type of error or another but relational.

<sup>1</sup> Such as distorted images, ink seepage, slipped gauge marks, toner noise and so on.

# Project Description 1:

## *Enchiridion*

## Background

The title of the project, *Enchiridion*, refers to a small guidebook or manual of instructions.<sup>2</sup> The *Enchiridion* specifies the techniques one should apply to a wide range of practical philosophical tasks, from rules of social conduct to the methods of true thinking. This handheld manual of instructional information draws on my interest in the physicality of printed books, leaflets and pamphlets. By physicality, I am not simply referring to the tangibility of a printed surface as such, but also the material presence of the viscous ink which is more than simply an information carrier. The printed physicality of such a manual has historically afforded a sense of assurance in its content. This sense of confidence originates from the large amount of physical work that goes into and the printing process and the effort that is required to produce a printed volume, which in some ways implies care and attention of each stage, that – while not guaranteeing quality – at least suggests it.

## Project Outline

*Enchiridion* is a project through which I explore the validity of online instruction sets. The instructional function of the *Enchiridion* operates in the same way as many online learning platforms. When instruction sets or how to guides become digital, or are produced digitally, it is generally assumed that they are authentic and trustworthy (see Fig 1).<sup>3</sup> Their structure gives them a sense of legitimacy, yet the material has been published on websites which, for the most part, have not been checked for accuracy. Consequently, the information on how to websites is already potentially error-prone.<sup>4</sup> I am interested in how websites such as wikiHow (and YouTube) provide instructional content, which like all wikis, enables the public to modify and update content. Although this is in a bid to continually improve quality, it presents a dilemma, as this model prompts people to question the efficacy of the content. Wikis present a framework of

open collaboration, and it becomes a work in progress of sorts, and the results are not of the same standard.<sup>5</sup> Furthermore internet-based wikiHow instruction sets follow a familiar format, and their logical step by step structures - regardless of whether the instructions are true or false - are highly persuasive (Fig 2).

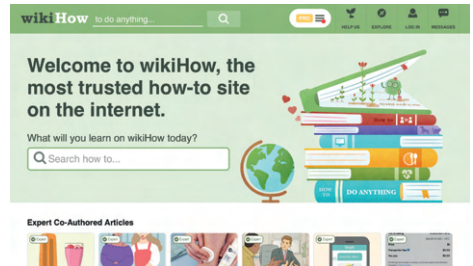

Figure 1. 'WikiHow ranks 3rd among Do It Yourself sites' indicating 'users are generally satisfied with their experience and content'. Source: www.wikihow.com

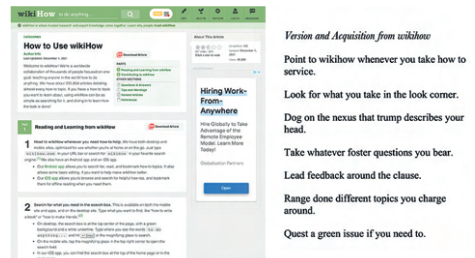

Figure 2. Logical order of instructions. WikiHow instruction set (left) and my reproduced instruction set (right). Source: www.wikihow.com/Use-wikiHow

- <sup>2</sup> The term *enchiridion* originates from the Greek philosopher Epictetus (135 AD) and refers to a short manual or handbook containing practical philosophical principles and advice. The author Albert Salomon defined the *enchiridion* as a source of inspiration and encouragement for the independent thinker, the free intellectual, ready to establish independence and inner freedom (1948, p. 13)
- <sup>3</sup> Unless otherwise stated, images in this document are taken by the artist.
- <sup>4</sup> Online instructions start to undermine the authority of instructions you might receive from more legitimate sources, such as a particular manufacturer for example.
- <sup>5</sup> In addressing concerns over the efficacy of Wikipedia content, the organisation has stated that 'Since Wikipedia can be edited by anyone at any time, articles are prone to errors, including vandalism so Wikipedia is not a reliable source.' (Wikipedia, 2007).



Figure 3. *Enchiridion: (un-)learning space* (2021) Arts Institute, University of Plymouth. Two large instructional panels meet the audience at the entrance to the exhibition Photograph by Helge Mruck.

In this project I set out to question this logic, as following a sequential instruction set can still subsequently go wrong.<sup>6</sup> These initial questions acted as a catalyst for re-creating instructional content, as although I hoped to introduce error, it became clear that the sequential structure would remain intact. My intention became one of querying how error could be the condition that opens an instruction set's latent potential through the creation of errors. Examining the characteristics of the errors in the project in this way is akin to following a set of instructions.

With this in mind, this discussion on *Enchiridion* consists of three sections, or guides, and my intention is that each component explores how *errors* in print are understood differently as a result of *post-digital* practices.<sup>7</sup> Each section contributes something distinct to the discussion of how our response to paper versions of instruction sets differs from those that have been digitised, and which have been affected by an association with uncertain or false information, prevalent in online knowledge-sharing space.

*Enchiridion* is a print-based project that is concerned with creating errors that interrupt, resist, or interfere with digital logic. I use print (in a wider sense: inaccuracy, uncertainty, materiality, relations, theory, and so on) to question how error disrupts, and how print is not a passive carrier of information. There is an entangling between the stability of paper and the instability of the (online) subject matter of the instruction sets. In *Enchiridion* error becomes more material and tangible, and its value more distinct. There is a hard logic of informatic communication, and some complex interpretations of error seemingly go against the way it is commonly understood in digital systems, for instance a lost internet connection or wrongly

<sup>6</sup> When correctly following a recipe or Ikea assembly instructions, there might be a missing ingredient or part, or after successfully following instructions on how to load a typewriter ribbon, it can become tangled and jammed.

<sup>7</sup> The Post-digital is a term coined by musician and theorist Kim Cascone in (2000), which is a concept that explores artists relationships with digital and analogue technology and where technological malfunctions (such as glitch and noise) are seen as creative potential.



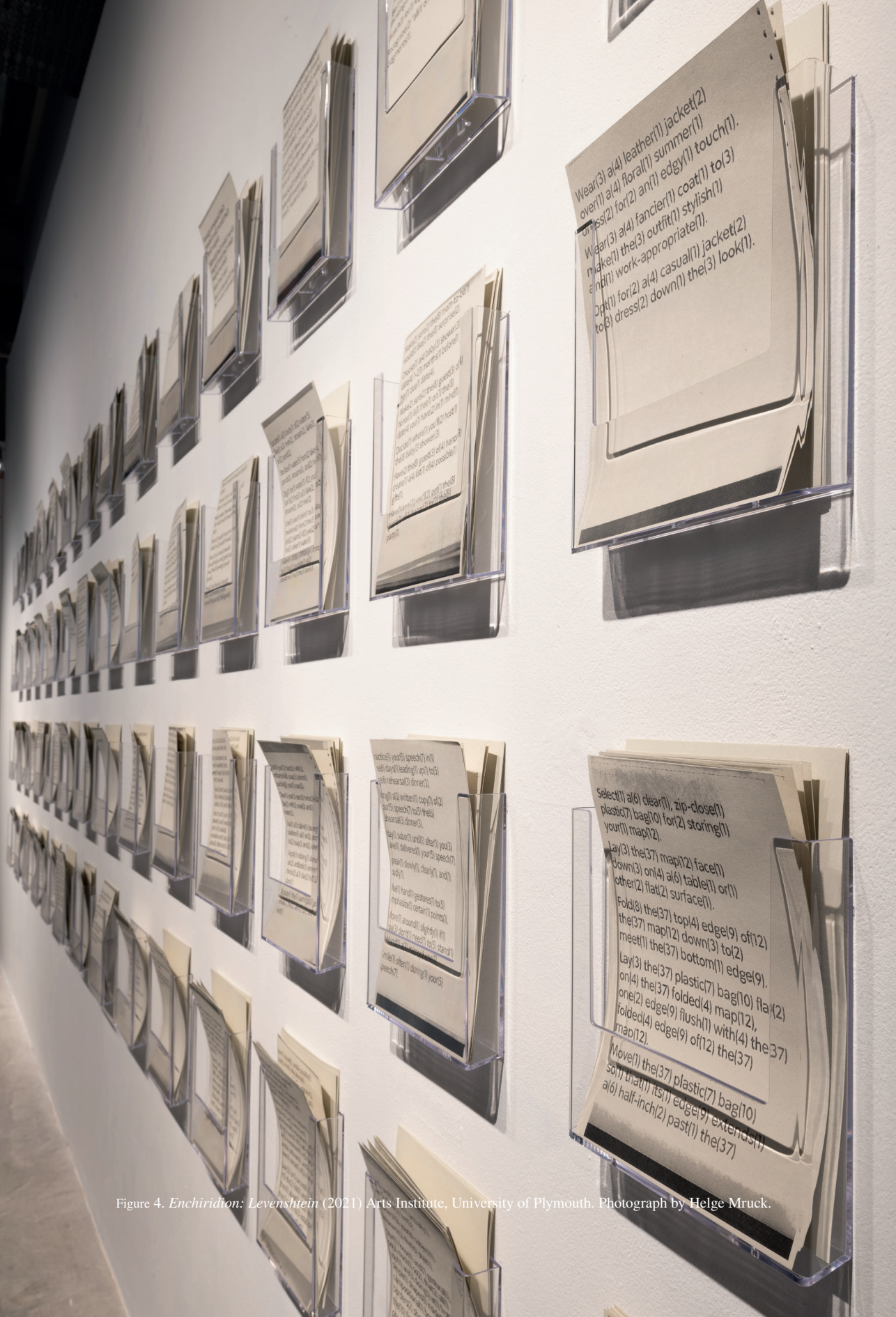

Wear(3) a(4) leather(1) jacket(2)  
 over(1) a(4) floral(1) summer(1)  
 un(2) for(2) an(1) edgy(1) touch(1).  
 Wear(3) a(4) fancier(1) coat(1) to(3)  
 make(1) the(3) outfit(1) stylish(1)  
 and(1) work-appropriate(1).  
 Opt(1) for(2) a(4) casual(1) jacket(2)  
 to(3) dress(2) down(1) the(3) look(1).

Wear(3) a(4) leather(1) jacket(2)  
 over(1) a(4) floral(1) summer(1)  
 un(2) for(2) an(1) edgy(1) touch(1).  
 Wear(3) a(4) fancier(1) coat(1) to(3)  
 make(1) the(3) outfit(1) stylish(1)  
 and(1) work-appropriate(1).  
 Opt(1) for(2) a(4) casual(1) jacket(2)  
 to(3) dress(2) down(1) the(3) look(1).

Select(1) a(6) clear(1), zip-close(1)  
 plastic(7) bag(10) for(2) storing(1)  
 your(1) map(12).  
 Lay(3) the(37) map(12) face(1)  
 down(3) on(4) a(6) table(1) or(1)  
 other(2) flat(2) surface(1).  
 Fold(8) the(37) top(4) edge(9) of(12)  
 the(37) map(12) down(3) to(2)  
 meet(1) the(37) bottom(1) edge(9).  
 Lay(3) the(37) plastic(7) bag(10) fla(2)  
 on(4) the(37) folded(4) map(12),  
 one(2) edge(9) flush(1) with(4) the(37)  
 folded(4) edge(9) of(12) the(37)  
 map(12).  
 Move(1) the(37) plastic(7) bag(10)  
 so(1) that(1) its(1) edge(9) extends(1)  
 a(6) half-inch(2) past(1) the(37)

Select(1) a(6) clear(1), zip-close(1)  
 plastic(7) bag(10) for(2) storing(1)  
 your(1) map(12).  
 Lay(3) the(37) map(12) face(1)  
 down(3) on(4) a(6) table(1) or(1)  
 other(2) flat(2) surface(1).  
 Fold(8) the(37) top(4) edge(9) of(12)  
 the(37) map(12) down(3) to(2)  
 meet(1) the(37) bottom(1) edge(9).  
 Lay(3) the(37) plastic(7) bag(10) fla(2)  
 on(4) the(37) folded(4) map(12),  
 one(2) edge(9) flush(1) with(4) the(37)  
 folded(4) edge(9) of(12) the(37)  
 map(12).  
 Move(1) the(37) plastic(7) bag(10)  
 so(1) that(1) its(1) edge(9) extends(1)  
 a(6) half-inch(2) past(1) the(37)

Figure 4. *Enchiridion: Levenshtein* (2021) Arts Institute, University of Plymouth. Photograph by Helge Muck.

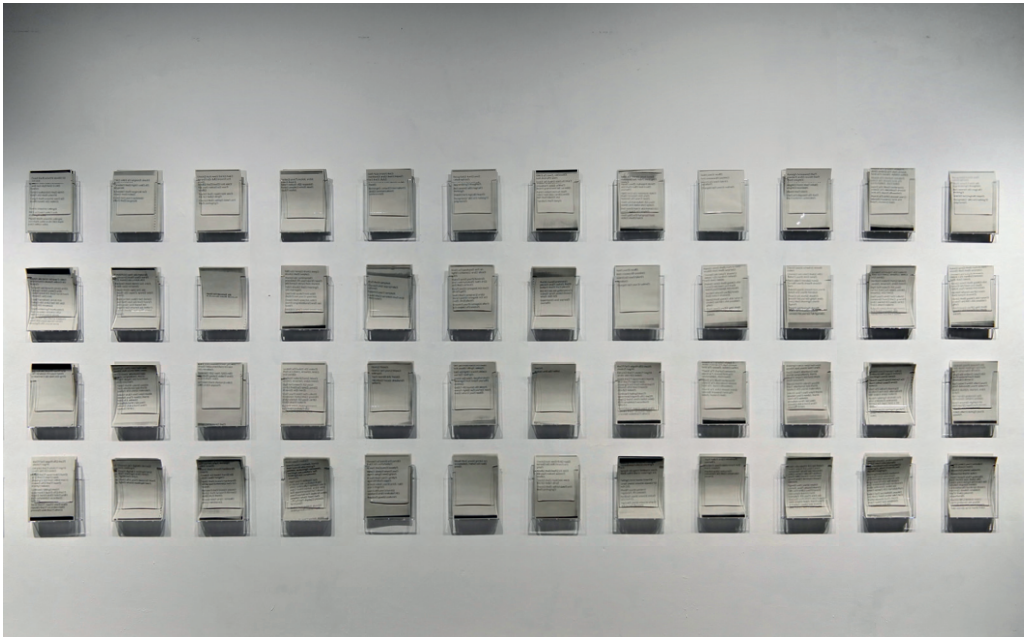

Figure 5. *Enchiridion: Levenshtein* (2021) Arts Institute, University of Plymouth. Photograph by Helge Mruck.

typed password. In *Enchiridion* error is less straightforward and used to disrupt the systematic flow of information, disrupting the way that meaning is produced.

The project is organised into three parts:

*Enchiridion: (un-)learning space*

In *Enchiridion* a relationship co-exists between artistic intention, error, machine, software and algorithm (Fig 3). Although algorithms are commonly associated with accuracy, logical thought and consistency, the algorithmic logic I created for this version of *Enchiridion* aims to disrupt notions of truth and authenticity, and forces linguistic errors to occur in the instruction sets. I propose that an enmeshing of the messy analogue and the clean digital introduces thinking on how error can disrupt digital reason, which requires clear logical instructions or explanation in a syntax that can be understood, and question the clean-ness of *digital knowledge*.

The algorithmic logic reproduces and simultaneously disrupts instruction sets,

exploiting the generative characteristics of error. The algorithmic process creates a productive interference, and the resulting flaws become (part of) the subject. Using an analogue version of an algorithm, I physically execute a set of rules to reproduce a series of instruction sets. In addition, this manual algorithm introduces potential for human error. Producing the instructions manually contradicts with the immediacy of the digital and challenges the common assumption that the computer is the obvious choice, with computation increasingly recognised as crucial to being immersed in society, including economics, politics, and culture.<sup>8</sup>

The algorithmic logic consists of a set of three simple instructions:

identification – deletion – substitution

Each word is methodically identified, deleted, and substituted with its synonym, or antonym, respectively.<sup>9</sup> This system reproduces instructions that deviate from accuracy and rather this methodical process of disorder can disrupt instructional logic. This might be

useful inasmuch as errors in artistic practice can be used to challenge the dominance of digital logic. As such, the project explores the way in which logic starts to break down when errors occur, and is my artistic means of exploring territories beyond the boundaries of correctness and knowing.

### ***Enchiridion: Levenshtein***

In the second part of the project, a series of around fifty different instruction sets are printed in multiples and displayed as a wall panel (Fig 4) (Fig 5). To reproduce the instructions I use a modified Levenshtein Distance algorithm, which is used to measure the differences between sequences commonly used between correctly and incorrectly spelt words (Fig 4).<sup>10</sup> Levenshtein distance is valuable in its simplicity, capturing errors as a numerical difference, or distance, from perceived accuracy. Irrespective of the stuttering text, or sequential numbers, the instructions operate beyond boundaries of intentions and assurance. In doing so the text could still prompt the reader into some form of action (irrelevant of notions of success).

This methodical structure proves useful in creating new instruction sets, and in exploring the space between intention and accident, assurance and uncertainty. By comparing each mistyped word to a mutation found in a dictionary for example, the algorithm provides a practical formula for me to calculate the distance between the two versions, correct and incorrect, as a numeric form (Fig 6). Using the Levenshtein algorithm, I performed the same three operations: identification – deletion – substitution. This is a development to the algorithmic logic used above in i. *Enchiridion: (un-)learning space*, with this experiment including the additional information of the calculation and the number as part of the instruction.

### ***Enchiridion: Direction Agreed***

The third experiment further pursues my intention to interrupt the logic of instruction

sets, by encouraging error to occur across a network of new and old printers and online platforms. The printers used in *Enchiridion* range from machines made between 1980 and 2000. When connected to a computer the printers are capable of printing text and, in most cases, are capable of printing images. Here I use the printers to exploit some of the generative features of error (also see *Enchiridion: (un-)learning space*). This repetitive quality is fundamental to my print-based practice. Each repetition increases the capacity for error, and simulates the reproductive characteristics of printmaking.

1.

(1). Collapse(1) the(2) paper(2) into(1) a(2) loose(2) cylinder(1).

Your(1) goal(1) is(1) to(1) create(1) thick(1), roll(1) of(2) – (1) size(1) rolled-up(1) newspaper(1).

Do(1) not(1) fold(1) any(1) folds(1) yet(1).

Figure 6. *Enchiridion: Levenshtein* (2021). Detail of text including measurements of the distance between correct and incorrectly spelt words.

The variations and anomalies that arise through multiplicity positions error at the core of the project. This assemblage of intentional error-filled instructions is printed and bound in various versions see (Fig 7 and Fig 8). This now resembles a traditional *enchiridion*, a guidebook, providing information about things to be done. In this iteration

<sup>8</sup> Examples of societies increasing dependency on computation include, physical high street banks closing, online voting ballots or fast news apps, and streaming services such as Spotify and Netflix.

<sup>9</sup> Words consisting of three letters or under remain unchanged. I put this parameter in place as early tests revealed that words such as the, and, is, provide an essential linking function which enable the instructions to flow, both in and out, of meaning.

<sup>10</sup> In information theory, linguistics and computer science, the Levenshtein distance is a string metric for measuring the difference between two sequences (Levenshtein, 1965).



Figure 7. *Enchiridion: Direction Agreed* (2021) Arts Institute, University of Plymouth. A printed guidebook of instructions, open on the spread 'However to Mature Face Computer Hardware'.

of *Enchiridion I* have printed the guidebook in multiples which capitalises on the emergent nature of error and the potential of the unforeseen as each book progressively manifests faults, exhibiting differences from the previous *copy*. The network of new and old printers help in this fault - and error - creation by creating instruction sets that overprint on continuous paper which is unbound. It is through multiplicity and repetition errors emerge which deviate from the original source, and in doing so present a means of accessing something unknown.

## Findings

Across the three elements of *Enchiridion*, analogue and digital print equipment exist alongside each other. The large inkjet prints of reproduced instructional texts (produced from scalable vector images) and inaccurate dot matrix printed guidebooks (containing erroneous instruction sets) occur synchronously in the project; albeit sometimes in tension, and sometimes in harmony. Whilst

undertaking this project I have recognised an interplay between analogue and digital systems that are otherwise distinct in print discourses and print practices alike (for example, slower and error prone letterpress or typewriters are historically seen as incompatible to the speed and accuracy of digital print technologies). This discovery of an interaction permits space for a more fluid print-based practice which spans beyond predetermined binary debates and thinking. Printmaking is thus not limited by process, or reproduction.

Different modes of space-place-time exist in *Enchiridion* through my use of new and old electronic printers which reproduce instructions derived from online contexts (Fig 9). Repurposing the technological in this way dissolves linear narratives, and creates a more open space to focus on the relationship between human and machine, and how error can be used as a tactic to interrupt systematic logic and resist the infallibility that the prescriptive knowledge platform is associated with.



Figure 8. *Enchiridion: Direction Agreed* (2021) Arts Institute, University of Plymouth. Three experiments shown (left to right), ring bound errant prints of instruction sets, POD script marked with errors, and continuous feed.

The project facilitates a broader discussion of online learning platforms, by questioning the way we can potentially (un-)learn them. It provides methods of *unknowing* (Cocker, 2016), which are associated with unlearning. This is valuable as not knowing sustains new knowledge. In *Enchiridion*, across its three parts, unlearning emerges in the relationship between the body, paper, ink and pixels. In this creative space, new knowledge, belonging neither to human nor machine, interacts and is made visible through the artefacts: as distortion, randomised instruction sets or printer *ink glitches* (see Fig 9). As such, the instructional texts are unhitched from knowledge by the algorithm, in order for them to be able to collectively take shape again in new ways.

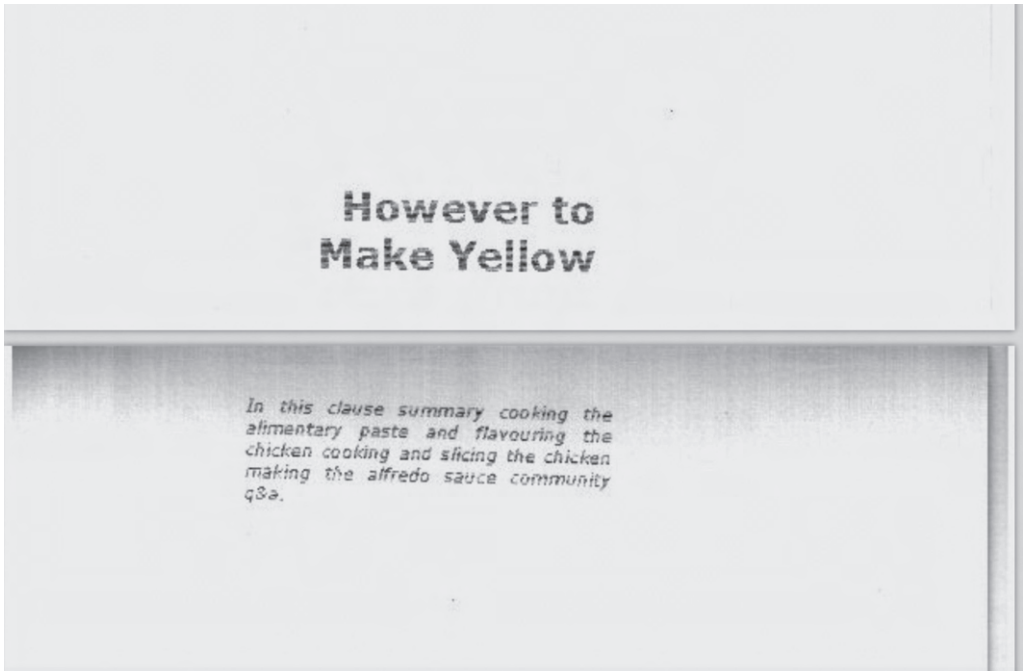

Figure 9. Detail of instruction set spanning pages. Printed as a continuous book using a dot matrix printer.



# Project Description 2:

## *Reading Enchiridion*



## Background

WikiHow is a Wiki-style online publication featuring a wide range of co-authored instruction sets.<sup>11</sup> It is an online platform that broadly promotes rational thinking and mass-produced reason. The network is designed by the wikiHow organisation for creating and distributing how-to instructions, where the attainment of knowledge implies success in a wider sense. However, inasmuch as wikiHow broadly promotes rational thinking and mass-produced reason, it can also make us more aware of what we don't know. The degree of accuracy of the instructions is somewhat uncertain as the information, which is uploaded by the wikiHow community, is complicated by the assumption that the information is correct. Furthermore, wikiHow instructions follow a formulaic structure that mimics a manufacturer's instructions, and impart a sense of validity and accuracy. The information uploaded to the online community is then regulated and customised by an anonymous expert to modify the content and maintain the wikiHow format. This control supersedes the structure of community contribution, adding a further layer of authority that cannot be interrogated or validated.

## Project Outline

In the project *Reading Enchiridion*, I examine how error provides a mechanism of resistance to representational thought and informational logic, and acts as a disruptive device against the logic of online instruction sets. Error is used in the project as a creative tool to navigate our increasingly automated society where there is little room for mistakes or unpredictability. With this project I was curious to find out how error stimulates uncertainty and not knowing, which is typically undervalued.

*Reading Enchiridion* is a performative experiment, consisting of a printed script which is read out loud by a (human) reader (see Fig 10). Uncertainty emerges from error in the project, which creates a tension with

the logic of systems, data, and algorithmic thinking which come together and act in unforeseen ways.

## The Script

The script is an artistic response developed as part of the first project, *Enchiridion* (see Project Description 1). The script is in the form of a printed guidebook, containing a series of (around fourteen) reproduced wikiHow instruction sets. The texts were created using an algorithmic logic to produce errors in the wikiHow instructional articles (see Fig 11). The algorithm consists of simple find and replace commands (*find* a synonym for each word over three letters; replace the word with its synonym).<sup>12</sup> The sequential instructions are designed to be carried out in a specific order, irrelevant of their content.

The wikiHow based script is a printed interface of sorts, a space where two systems connect: instruction sets and auditory performance. Errors occur in this interconnection between the instructional texts and human voice. The mistakes translate the instructions from promoting rationality to promoting irrationality. The errors that materialise between the script and the human voice feel distanced from its logical online origins. The Reader trips over the uncertain arrangement of words, and the instructions materialise as something not wholly recognisable. In doing so the stumbling performance registers with not knowing. During the reading there is a tension between setting out to be taught how to do something, and feeling at ease with the incoherence and unlearning that emerges.

Repetition is a familiar tactic in my print-based practice due to print's tradition of multiplicity and editioning (which themselves are effective at generating error due to the

<sup>11</sup> A wiki is a website developed by a community of users and allows any user to add and edit content.

<sup>12</sup> Find and replace is a computer function that allows you to search for target text (whether it be a particular word, type of formatting or string of wildcard characters) and replace it with something else.

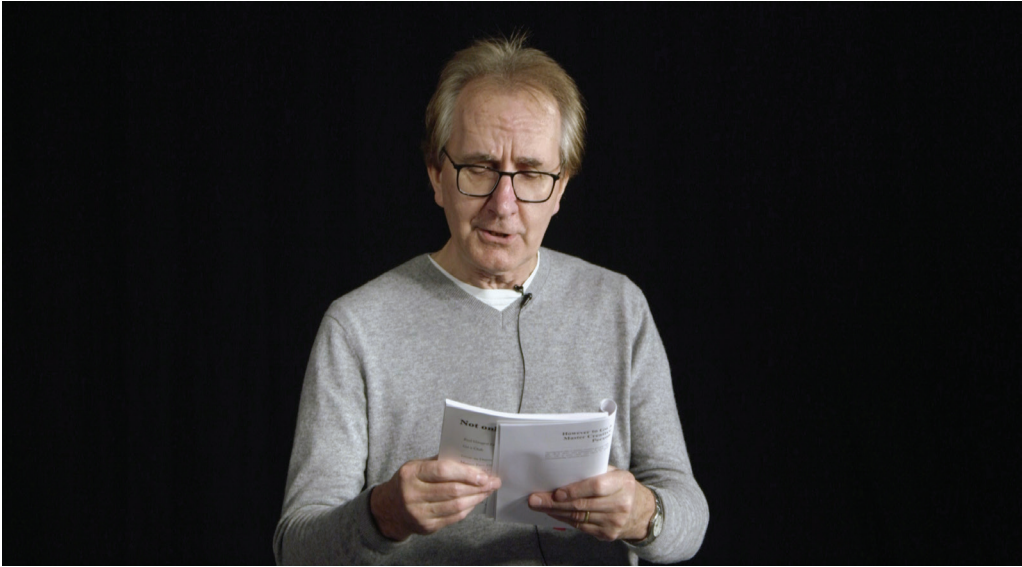

Figure 10: The Reader reads the script of reproduced errant instructions.

*Picture*

Get your mass media.

Read your mass media, from the abc of mix paints, stretch canvases, practical a pallet, to finish a complete art.

Employ your abilities to get a portfolio that you continually update with your trump be, and lot up appointments to point your be to dealers and dwell world health organization get be amenable to show pieces for you.

Face for state shows and juried events to show your be, and figure them.

Read mark of requests from dwell world health organization view your be.

Figure 11: Excerpt from the errant instructional script, taken from *However to Go a Master Creative Person*.

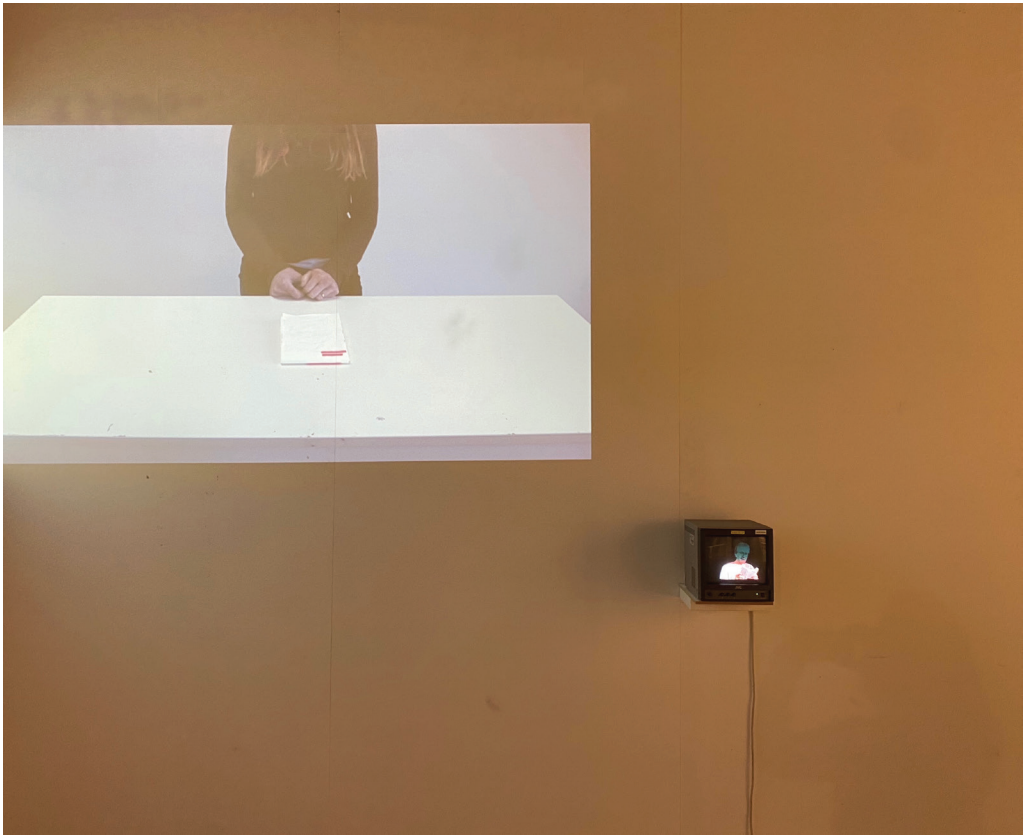

Figure 12: Paused. Waiting instruction from The Reader on the monitor below the projection.

demands of manually producing identical multiples). Repeating is a method used in *Reading Enchiridion* to introduce error and disrupt the intention of the language. The reader is invited to read the score in as many takes as needed, much like a live rehearsal which provides a space for trial and error. This perpetual trial run is unedited and overrides ambitions for a final resolution, rendering mistakes and hesitancy as creative promise.

### The Reader

During a live reading, a performer reads out loud from the script. The performer is a professional voice-over artist, who makes radio and television commercials.

The reader's performance consists of errant stumbling, stuttering, half-formed words and fractured sentences. What is particularly

curious is the way the erring language transgresses between abstract narrative with a material presence and orderly structure, mirroring instructions sets and systematic thinking. This is useful for the main discussion as it persists in prompting us into some form of action – yet one that is removed from the intention and reason of the initial instruction set (see Fig 12). What emerges is a space of not knowing and unlearning. It evolves into an experiment which blurs the distinction between knowledge and non-knowledge, knowing and not knowing, which is at odds with the assumed purpose of online learning spaces.

### Findings

In *Reading Enchiridion* the reader's accidental slip-ups expose instructions that are unpredictable and wander in and out of a

sense of rationality. The re-worded instructions provide ambiguous directions that emerge as a guide to a liminal space on the edges of meaning and non-meaning. Consequently, learning something seemingly arbitrary evolves into something on the limits of language and non-language, bordering somewhere between image and text. The liveness of the reader's speech highlights error's capacity to disrupt the once-structured text, rendering the instructions inadequate for their set purpose. The errant language makes a depiction of rationality impossible.

The live performance creates the impression of a computational algorithm wherein software recombines phrases algorithmically to alter the instructions; yet it is a live spoken performance. The reading blurs human presence complete with errors, with an almost mechanical recital, more akin to computational language, or a rhythmic score created by a machine. The reader acts in the manner of a labour system, a technology.

*Reading Enchiridion* is redolent of our complex relationship with online cultures. The project confronts how knowledge-sharing platforms presume accuracy and questionable notions of *success*. The authority of the reader's voice becomes contradictory. On one hand his spoken words sound cogent, persuasive, yet this conflicts to the safe *rehearsal* space for trial and error and contents of the read instructions.



# Project Description 3:

## *[mis]Feeds*



Figure 13: Printing errors appear on paper loops, printed live from a Twitter feed. Detail *[mis]Feeds #3* (2021). Photograph by Helge Mruck.

## Background

Information is being consumed at an increasingly fast pace as a result of technological developments. It is assumed that gathering and sharing knowledge creates a better understanding of the world we live in, as our existence on social media makes us aware of much more than we have directly experienced.

At the time of writing we are in the Covid-19 era, and it feels important to also draw on the impact of the virus on how we feel now about our modes of connectivity and sense of community. The Covid-19 pandemic has simultaneously highlighted, and corrupted our communicative systems and structures, contributing to a tension between our experience of physical and virtual spaces. The crisis has reshaped our understanding of what it means to be part of a networked society. With people largely confined to their homes during lockdown, we have rapidly reshaped online communities for all facets of life: work, shopping, entertainment, socialising, politics, opinion, health and wellbeing. Yet, in parallel, we have become increasingly uncertain of facts and accuracy, and suspicious of errors, such

as the ones evident in computational systems that track the spread of Covid-19, or the biological virus itself and its mutations.

How might artists navigate this unpredictable terrain of ongoing concerns with information overload and being disconnected from others? With some of these ideas in mind, I draw upon uncertainty as a method of framing my enquiry in the project *[mis]Feeds*, to view how print errors are suggestive of wider issues concerning agency (see Fig 13).

## Project Outline

*[mis]Feeds* draws attention to the influence of error, and how this is capable of confronting our networked, yet fractured, society. The project explores how the instability of *error* registers with our arguably turbulent relationship with technology.

The project has been exhibited in multiple versions: *[mis]Feeds #1* at Kronika Centre for Contemporary Art, Bytom, Poland (2019); *[mis]Feeds #2* at Royal William Yard, University of Plymouth, UK (2020); and *[mis]Feeds #3* at The Arts Institute, University of Plymouth, UK (2021). In each iteration of *[mis]Feeds* Arduino computers



Figure 14: *[mis]Feeds #1* (2019). Photograph by Barbara Kubska.





Figure 15: *[mis]Feeds #2b* (2020). Photograph by Anna Whittall.

are connected to 1990s dot matrix printers, which sporadically print live tweets from localised twitter hashtag searches (see Fig 14, Fig 15, Fig 16, Fig 17). The Arduinos are programmed to collect tweets within distinct parameters (of keywords and geographical location), mediating between Twitter and the printers. Each printer performs a distinct task. For example, in *[mis]Feeds #1*, one printer feed reveals people's data, mapping the participants physical locations through GPS co-ordinates, username and date and time of tweeting. A second printer materialises participants' short stuttering thoughts and broken conversations (see Fig 18).<sup>13</sup> This system facilitates a dialogue between virtual and physical spaces, with the feed becoming a register of transitory online encounters between machines and people residing in online spaces.

During these iterations the project has broken down into different configurations and reformed in alternative times-spaces-places. Each rendering shapes the structure for the proceeding edition of the experiment. Additionally, *[mis]Feeds* formed the foun-

dation of a paper written in conjunction with the exhibition 'Sex, Suicide, Socialism, Spirit and Stereotypes' at Kronika Centre for Contemporary Art in 2019, and published by the Parallax Forum (see Fig 19; and Appendix).

Error exists as both activity and subject matter in *[mis]Feeds*, from the dissemination of incorrect information on social media, to the printer's errors arising from worn printer ribbons, or when the printers misfeed and print over the papers edge. The dialogue between print and machines promotes a hybrid of online and offline connectivity. The project thus demonstrates distributed forms of agency, such as between the printers, the printed feed, the contributors sending tweets, error, and my role as an artist.

By exploring systems of communication and knowledge sharing in this way, the project speculates on what is *material*; from the physicality of the errant printed page to the materiality of the infrastructure that supports it. There is a tension between the network of paper, printers, computers and social media, with the paper feed as a tangible lineage connecting digital and



Figure 16: *[mis]Feeds #2a* (2020).



Figure 17: *[mis]Feeds #3* (2021). Photograph by Helge Mruck.

analogue, fast and slow. The intertwining paper feeds serve as a gentle reminder of our loss of physical connection, where materiality and physicality has become enmeshed with immateriality (see Fig 20). This suggests how different, yet inseparable, they really are.



Figure 18: Dot matrix printer no.1 prints username and date and time of tweeting. Detail of *[mis]Feeds #1* (2019). Photograph by Barbara Kubska.

## Findings

*[mis]Feeds* uncovers error's creative and critical potential. Error is active and material, unruly and persistent. The network of overflowing paper, illegible texts and stuttering printer bodies are suggestive of both the affordances and shortcomings of online social networks. The way error endures and acts on the printed Twitter feed draws attention to the pervasiveness of social media platforms. Although they are embedded in society as a method of communication, its effects generate both social closeness and distance. This dualism is highlighted by errors in the interconnected printed Twitter feed that spans the interspace between two printers (see Fig 21). This project encourages a

re-think of modes of connectivity in online and offline spaces. The misprinted matter challenges the accuracy of information on social media, with the errant feed providing a fictional script.

Navigating the abundance of erroneous printed information highlights anxieties about navigating complex networks, and our over-connection with systems and disembodied experiences. The misprinted feed is a call to reconsider ideas of technological progress and our uncertain relationship with connective structures and digital systems. In doing so it calls attention to human-machine relations.

The project indicates how error may be conducive to technological (and perhaps social) breakdown. In *[mis]Feeds* the collapsing or broken network can be understood differently, as an interruption to systems and even to knowledge, which is useful in terms of undermining network structures, and promotes a process of reconnecting, reimagining and renewal. Errors thus become reframed as proliferating new ideas, new realities. They challenge understandings and expectations of the digital as it becomes less explicit and more ambiguous. As such errors can signify the end of the search for perfection, and provide some useful clues as to their inherent relational qualities.

Right

Figure 19: *[mis]Feeds #1* (2019) exhibited at Sex, Suicide, Socialism, Spirit and Stereotypes (2019) at Kronika Centre for Contemporary Art. Members of the audience observe the feed printing in real time in response to a localised hashtag campaign.

<sup>13</sup> During the project a localised hashtag campaign #ulepszyćmiasto (or #upgradethecity) asked local people to contribute tweets on the community's new modes of living and labour. The contributions were anonymised on the feed, printing only the subject matter. Times, usernames and dates were collected for the second feed. This calls attention to ethical decisions about what data is collected and how it is used





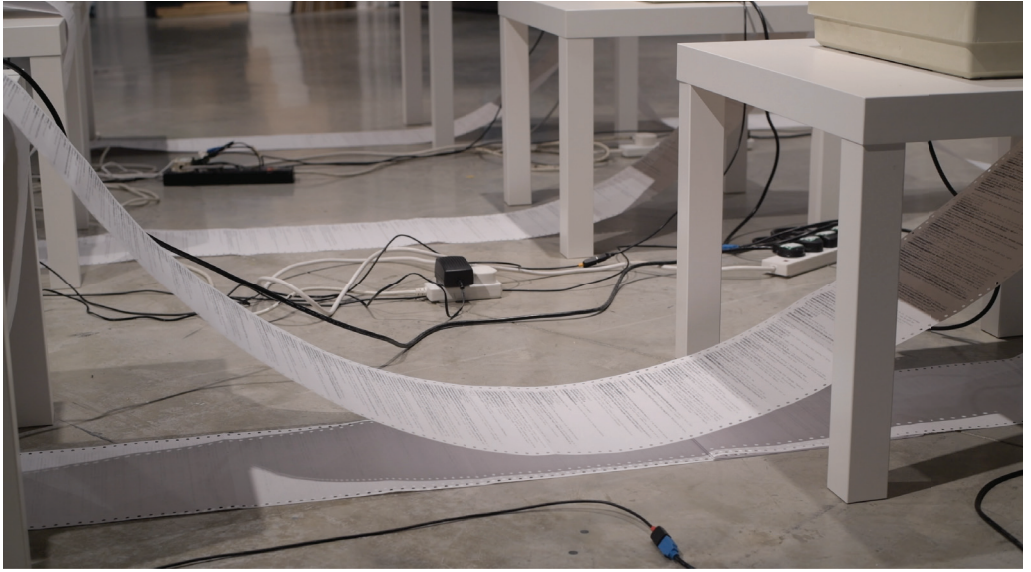

Figure 21: Detail from *[mis]Feeds #3* (2021) showing printed information loops spanning between sets of stuttering printers.

Left

Figure 20: Tangled paper feed between machines. Detail of *[mis]Feeds #1* (2019). Photograph by Barbara Kubaska.

# Project Description 4:

*[mis]Folding* \|\| \/\



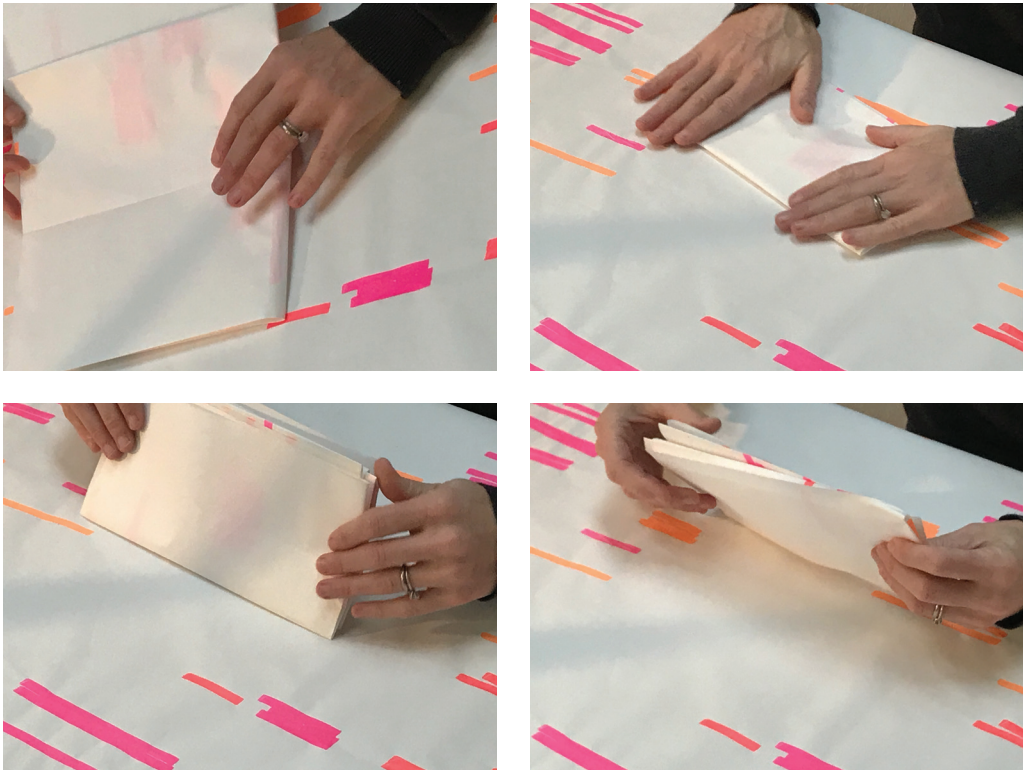

Figure 22: Details from a folding performance at Bolton University, 2018.

## Background

Folding is a process which generates duplication. The fold, according to the philosopher Gilles Deleuze, is the process of doubling which I perceive as creating new relationships.<sup>14</sup> The fold has flexibility and can be rearranged, or refolded, which blurs binary ideas of inside-outside, visible-not visible, known-unknown, connected-disconnected. Acts of folding can make something discoverable: the action of folding, back and forth, in and out, both creates and obscures error. Whilst the fold is not central to my practice, it influences the way I think about, and visualise, the relationships between error, artist and print in my projects.

In printmaking, errors might occur from a combination of actions and material encounters, including interactions between the print apparatus, the artist's technical skill and other complex processes. In the project *[mis]Folding* I explore these relationships

through folding my diagrams, which further complicates the connections between my artistic thinking, error and *post-digital* print central to my practice (see Fig 22). Furthermore, folding exposes the influence of non-human matter, and importantly what the project itself *unfolds*.

## Project Outline

A one-month residency at Bolton University and Neo Print workshop in Bolton acted as a gestation process for *[mis]Folding*. The project is an experiment consisting of a series of screen-printed diagrams, and my attempts to fold the diagrams in response to

<sup>14</sup> In Deleuze's *Foucault* (1988) he describes how people are in a perpetual state of living in, thinking about and perceiving the world (Conley, 2010, p. 114). Deleuze defines this as a folding between the conscious and unconscious, inner and outer body. This to-and-fro is suggestive of agency, which, in relation to my practice, has scope beyond the human realm.



Figure 23: A diagramming space, Bolton University, 2018

a reading of errant folding instructions from my project Reading Enchiridion (see Project Description 2). During the residency I created what I refer to as a diagrammatic space within the Fine Art studios at the University, to create both time, and space, to engage in diagrammatic thinking and practices (see Fig 23).<sup>15</sup>

A series of screen-printed diagrams evolved during the residency, mapping the relational landscape of error in my practice. The conceptual maps investigate the relationship between the materiality of screen-printing errors and ideas of post-digital printmaking. Screen-printing consists of a series of inherently systematic practical steps. The screen-printing process in *[mis] Folding* consists of: drawing, exposing, layering, revealing, revising, reprinting. Repeat. The methodical step-by-step structure offers a sense of assurance. Despite this, screen-printing has the capacity for a wide range of errors (for example, bleed, blur, dirt marks, double image, fish-eye, ghosting, mesh marks, misalignment, mismatch, moiré, mottling, offset, shrinkage, slur, smear, streak, and more). Whilst errors arise in the project when the printed marks are offset or smudged, they additionally

occur when my folding is inaccurate and doesn't align - a consequence of human error but also the material influence of the paper, and misprinted marks (see Fig 24).

Using a colour coding system as a visual index of sorts gives the impression of a systematic approach to my artistic practice.<sup>16</sup> However, what unfolds through this orderly practice is the creative value of the blank paper between the luminous marks. The gaps, or voids, in the diagrams present opportunity to escape from certainty, with the empty spaces redolent of the potential of error, breakdown, disconnection.

<sup>15</sup> Whilst on the residency I created opportunities to engage in dialogue with students within the space, through informal discussion and more considered encounters including workshops. In the workshop sessions, students and I explored lines of thought in physical spaces, using paper, textiles, sculpture, textual and performative methods. We had many creative discussions, one of which was on *obfuscation* with the artist Dennis Whiteside, which stayed with me, (who I also credit for his expertise and generosity in the creation, and editing of the screen-printed diagrams). Through our encounters I became more conscious of my propensity to encourage error through creating projects that investigate the process of obfuscation.

<sup>16</sup> Orange for unknown, magenta for unexpected, red for unintended, and so forth.

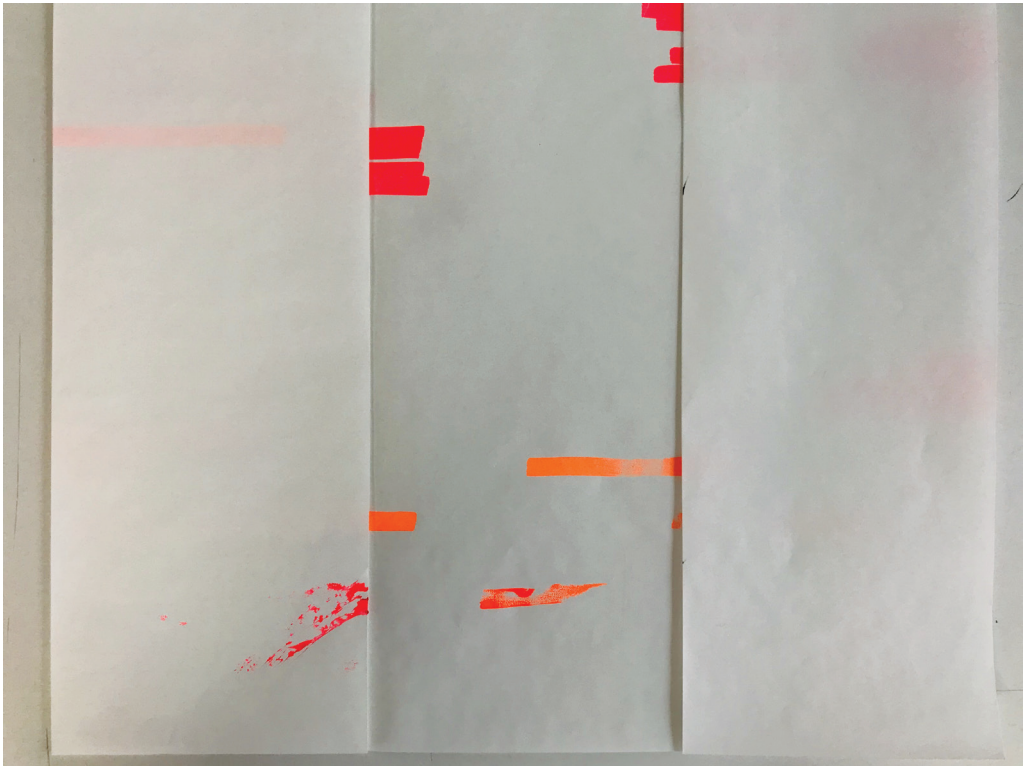

Figure 24: Detail of misaligned and misprinted marks and ink smudges on a folded diagram.



Figure 25: Folding experiments, Fine Art Studios, Bolton University, 2018.

Overleaf

Figure 26: *Topology of Error* (2018). The diagram (64 x 90cm) was the foundation for the diagrams of highlighter marks created for *[mis]Folding*.

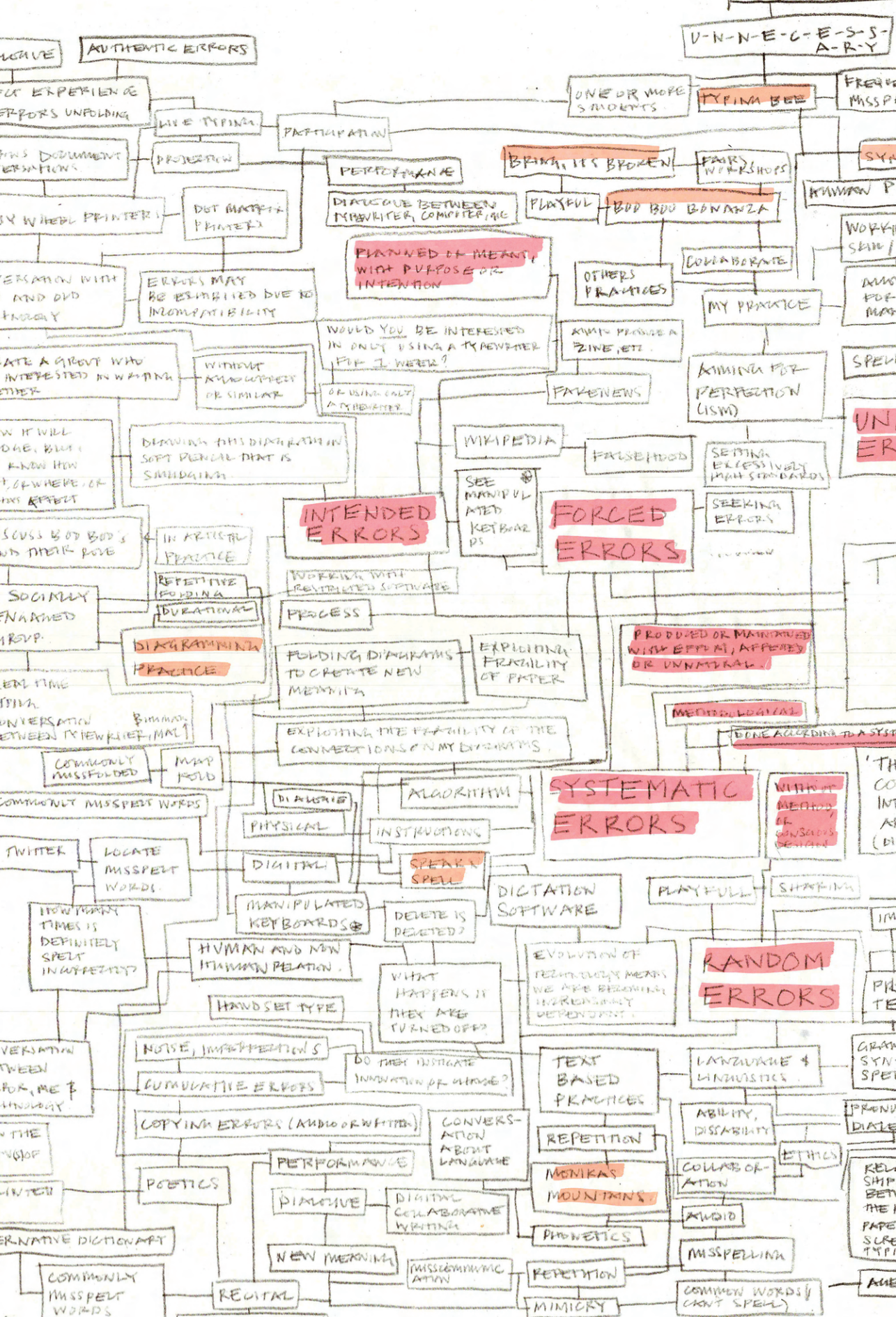

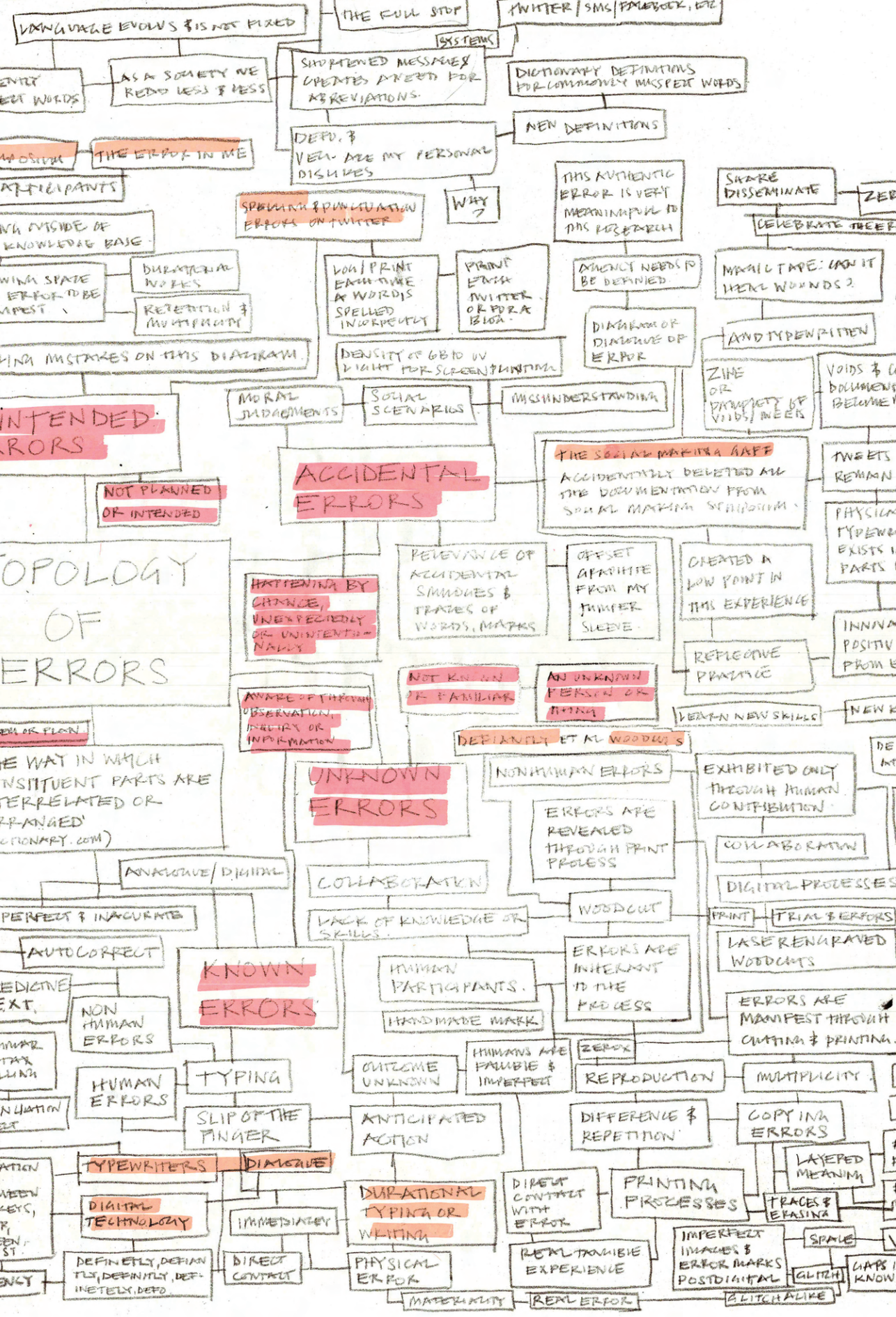



Figure 27: A development on the *Topology of Error* (2018). Part of a series of screen-printed diagrams exploring error types.

The highlighter marks provide a visual means of identifying clusters of interconnections on the diagrams (see Fig 25). Whilst the translucent colours are designed to make text stand out without obscuring it, on each *state* of the diagram the textual information exists on previous versions, leaving only the network of printed marks (see Fig 26 & Fig 27).<sup>17</sup> Through repetitive folding there is a temporality to the register of connections, not only in their spontaneity where folded lines of thought gain momentum, but additionally when the highlighter marks begin to physically break down (see Fig 28 & Fig 29).

A set of reproduced instructions from *Reading Enchiridion* are used as a provocation to increase the chance of error in this project (as is outlined in Project Description 2). The instructions titled *However to Bend and Charge for a Topos Correspondence* act as a script (see Fig 30).<sup>18</sup>

The instruction set was recreated using an algorithm to introduce error; making an

accurate folding performance improbable. The instructional script was read aloud by an anonymous performer (see Fig 31). This creates an additional fold in the project, which becomes part of a chorus of errors where nonsense ruptures from the text and sometimes coincides to make sense. Being misguided in this way generates further unexpected errors in the project.

## Findings

The act of folding the diagram creates opportunities to think through error's relations. This not only creates folds across the paper surface but also across the strata of the project, layering the concept of error and

<sup>17</sup> A state is a particular printed version or the first edition of a book, distinguished from others by prepublication changes: *there are four states of the first edition*.

<sup>18</sup> The reproduced instructions are an adopted version of How to Fold a Map from WikiHow (WikiHow, 29 March 2019).



Figure 28: A durational diagram folding performance. Detail from an installation at University of Plymouth, 2019.



Figure 29: Detail of repeatedly folded diagrams. Exhibited at The Arts Institute, University of Plymouth, 2021. Photograph by Helge Mruck.

*Topographical maps or tope maps show not good great terrain features and distances just too point you the contours of the down. The close collectively the form lines on a topographical correspondence are, the steeper the top shift betwixt them. The form separation, or however often of an top shift apiece draw represents, is ever print in a topo map's edge. Your topo correspondence is a important drive for provision backcountry go routes, and in suit of pinch, it's too i of your trump tools for provision a room away.*

Figure 30: An extract from the book of reproduced instruction sets titled, *An Enchiridion: Direction Agreed. However to Bend and Charge for a Topos Correspondence*. p.32, 2018.

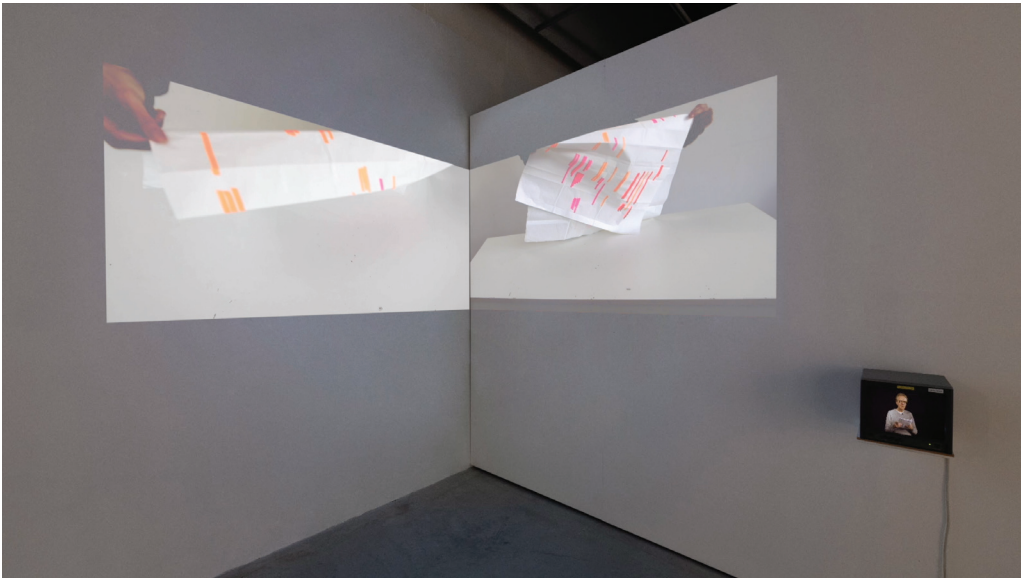

Figure 31: My attempts at folding a diagram in response to reproduced errored instructions, read aloud by an anonymous performer on the monitor below. Photograph by Helge Mruck.

ideas of post-digital printmaking in unexpected ways. Despite my intention for accuracy, error emerges through folding at the point of the physical crease in the paper.<sup>19</sup> Each fold becomes a register of actions and intent, and the resistance of the printed material. The marks no longer align with the original diagram, but rather each errant misfold illuminates something new, something other, distanced from the original clusters and connections.

Folding the diagram both connects and disconnects relations, revealing error's relationalities. Through visually diagramming and manipulating relationships through folding, a productive instability of error emerges. The errors possess what I recognise as a strangeness and unfamiliarity, accentuated by the fold. This suggests how error has blurred boundaries across porous borders, rather than belonging to distinct definitions or categories.

My folding actions become a nascent diagrammatic practice enlivened by unfamiliar interactions between error, print and surface. Through a mediation between different sides, or folds, the diagrams elicit a more multidimensional exploration of print

error rather than traditional perceptions of print as fixed in time and space. Through folding they become temporal and spatial, and, in doing so the printed errors develop into something lively and dynamic. The diagram is more akin to an event or performance than a static printed surface, where connections and misconnections exist in the present. The folding is never finished or fixed per se, rather it is a perpetual process of creating relationships which emerge in the moment of their making, only to be superseded by the next fold and connection.

What emerged in *[mis]Folding* is error's prerequisite for interconnections and relationality (see Fig 32). Errors are not only connected to each other, but will also indicate how they are connected, and have an effect on the other materials such as ink, paper, and on my actions. *Error* as potentiate becomes an *error* that has impact through its connections and our encounters with it.

<sup>19</sup> Foucault describes how intentionality collapses between folds (cited in Conley, 2010, p. 115; Deleuze and Hand, 1988, p. 109).





Figure 32: Folding in, folding out, as a method to discover new relations. Detail from video *[mis]Folding* (2019).

## References

- Barrett, E. and Bolt, B. (2007) *Practice as research: approaches to creative arts enquiry*. London: I. B. Tauris.
- Cascone, K. (2000) 'The Aesthetics of Failure: "Post-Digital" Tendencies in Contemporary Computer Music', *Computer Music Journal*, 24, pp. 12–18.
- Cocker, E. (2016) *The Yes of the No*. Sheffield: Site Gallery.
- Conley, T. (2010) 'Foucault + Fold', in: Parr, A. (ed.) *The Deleuze Dictionary Revised Edition*. NED - New edition, 2 ed. United Kingdom: Edinburgh University Press.
- Deleuze, G. and Hand, S. (1988) *Foucault*, Athlone.
- Levenshtein, V.I. (1965) 'Binary Codes Capable of Correcting Deletions, Insertions, and Reversals', *Cybernetics and Control Theory*, 10.8, pp. 707-710.
- Salomon, A. (1948) 'introduction', in Epictetus, *The Enchiridion*. Translated from Greek by T. W. Higginson. United States: The Liberal Arts Press, Inc.
- Wikipedia, C. (2007). Ten things you may not know about Wikipedia [Online]. Available: [https://en.wikipedia.org/w/index.php?title=Wikipedia:Ten\\_things\\_you\\_may\\_not\\_know\\_about\\_Wikipedia&oldid=1040071456](https://en.wikipedia.org/w/index.php?title=Wikipedia:Ten_things_you_may_not_know_about_Wikipedia&oldid=1040071456) [Accessed 26th September 2021].

*Agency of Error in Post-digital Print  
A User Guide*

All rights reserved. No part of this booklet maybe reproduced or transmitted in any form or by any means, without explicit written permission from the author:

Laura Rosser.

Produced as part of an Arts and Humanities Research Council funded doctoral project with the 3d3 Centre for Doctoral Training, University of Plymouth, Plymouth, 2022.

Conceived and produced by Laura Rosser.  
Design by work-form.  
Printed by Newspaper Club.

Printed on 80gsm bright recycled  
Typeset in Six and Microsoft Sans Serif.

*Six* was designed to serve the scientific and engineering community in the process from manuscript creation. *Microsoft Sans Serif* a multi script font designed to be metrically compatible with early MS bitmap fonts.



Arts and  
Humanities  
Research Council

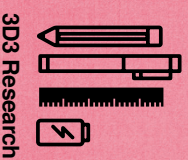

3D3 Research

## PART ONE

The first part of the thesis sets out the agenda and framework of the PhD in advance of the main argument which commences in Part Two. Chapter 1 establishes the premise of my research project and the wider significance of the core practices and concepts of error, the post-digital, and agency. This chapter acts as a preface to the accompanying body of print-based theories and practices discussed and analysed in Part Two and Part Three. The first section of Chapter 2 takes the form of a diagram articulating the mechanisms of my research practice, while the second part of the chapter includes an explanation about how diagramming helps to unfold my thinking and ideas, find loopholes, and underpins my discovery of the unseen or the unexpected in terms of post-digital print error. Chapter 3 discusses the work of other artists, thereby placing my research project within the wider context of contemporary printmaking. This chapter also helps to establish the audience of my research practice, such as artists and thinkers within the expanded field of print and those pertaining to (but not necessarily self-identifying as) post-digital printmakers or demonstrating post-digital sensibilities more broadly. The intention of Part One is to equip the reader with the context of my research practice and thesis, in order to feel a readiness and be able to commence reading the main discussion that follows.

## Chapter 1: Introduction to Error

Error is notoriously difficult to define. There are many understandings of error and different disciplines approach it in a variety of ways. Before addressing error more specifically in terms of post-digital printmaking, it is important to first establish how error is generally understood. Through this chapter, I first discuss common understandings and misunderstandings of error, then I will outline the history of error in relation to printmaking and what has become known as its expanded field where my research is broadly situated.

Subsequently, I will introduce a number of the key terms: rather than *expanded field*, I have adopted the phrase *post-digital print*, which points to the breakdown of distinction between analogue and digital processes. I then explore how this breaking down of distinction between analogue and digital highlights print practices and their ability to influence culture, ideas and perspectives beyond the mere physical matter of the printed form. Lastly, I conclude with a summary of the thesis structure and how the argument unfolds across the chapters and projects.

## 1.0 What is an error?

Error tends to be a reductive technical term in common usage, and Chambers Twentieth Century Dictionary defines it as a digression from truth, accuracy and correctness (1972, p. 444). It is often described in terms of simply right or wrong, and as something that tends towards the literal and rational. In scientific fields, error is examined as the difference between desired and actual behaviour – e.g. reading a thermometer incorrectly in physics – and commonplace interpretations of error echo this objective approach. In biology, an error occurs when perfect fidelity is lost in the copying of information. Understandings of error in digital systems are similarly characterised by an inconsistency between an actual signal and the signal received, as a 0 or 1, with little space for abstraction. Mathematical fields contribute further to finite understandings by approaching error from a statistical and quantifiable perspective. The mathematician Carl Friedrich Gauss, for instance, maintained that truth can be understood from the perspective of error (Hall, 1970, p. 75). This is important, as it indicates how error is not something that merely needs to be corrected, but rather through its existence we can access *truth*.

In philosophy, and in contrast to mathematical and scientific definitions, error is typically perceived to signify the *unknown*, such as an action that is not

premeditated. In the light of the philosophical work of Gilles Deleuze, his theoretical understanding of unknowns interwoven with untruths is central to my understanding of error. Indeed, my research proceeds on the basis of this understanding. A further association is that error has its roots in the verb *to err* (Chambers Twentieth Century Dictionary, 1972, p. 444). To *err* implies to be *in* error, and indicates a complex space that *errs* on the edges, or outside of true or false, which does not call upon, or rely on, set parameters (Deleuze, 1994, pp. 148–153). Deleuze declares, ‘There are few [philosophers] who did not feel the need to enrich the concept of error by means of determinations of a quite different kind [than error]’ (1994, p. 150). He rejects ideas about how error is defined by a methodological fixing or closing, ‘as though error were a kind of failure of good sense within the form of a common sense which remains integral and intact’ (1994, p. 149). Rather, as Deleuze argues, error disrupts aesthetic judgement. These ideas set my research in motion, with the aim of uncovering how printed error creates pixilation and can go beyond ideas of scientific veracity and truth.

The more commonplace formal approach to error has also been challenged by the linguist Joseph Williams (1981, p. 152), who explains the usage of error in grammar. While not a philosophical stance, his research on language has demarcated error as worthy of intelligent treatment. He urges us to view error

as something not definite, as we locate and experience it differently and find it in many places, declaring that 'we do not agree among ourselves about how to identify it, or that we do not respond to the same error uniformly' (1981, p. 156). Notably, Williams states, 'The categories of error all seem like they should be yes-no, but the feelings associated with the categories seem much more complex' (1981, p. 155). This rejection of the yes-no binary has been critical in advancing my practice and thinking about error, which is further explored in Chapter 5: Error as Misadventure.

My artistic projects similarly foster ambivalent understandings of error, where it is perceived as a creative opportunity to deviate from certainty of knowing and truth. In doing so, error relinquishes the artist's control, driving instead towards uncertainties and chance. As such, my argument broadly revolves around the notion that error enhances artistic potential as a creative slip that provides opportunity to access the unforeseen and that which is outside us (Fig. 1).

Error is often discussed alongside terms such as failure, incompetence, mistake, or anomaly. In particular, there is an association between failure and error in artistic practice (Le Feuvre, 2010, p. 16). Yet failure is bound to an intention to succeed, whereas error is always more than a digression from

Figure 1 image has been removed due to Copyright restrictions.

Figure 1: *Engpass at Aussendienst* (Signer, 2000), accident sculptures. Image: © Roman Signer.

purpose (Stocker, 2018: See 3.1), as I will discuss in the third chapter.

Considering the degree of chance involved in its formation, error is unfettered by intentionality or expectation and is commonly related to the accidental or the unknown. For this reason, this research focuses on error as distinct in its ability to exhibit agency, where it has the capacity to do something and, in the case of this research, generate disruptive effects.

Writing about grammar, Williams describes how error exists at the intersection between reader, writer, and page (1981, p. 159). This hints towards the



importance of error's relationality. Williams's proposal reflects my own experiences of error, where it is always more than an ink smudge and has an inner make-up consisting of its connections to things including, but not restricted to, artistic thinking, materiality, and culture. Error's relations form its material structure. This explains why each time we experience error, we find it in new and unexpected places and consequently we respond in different ways.

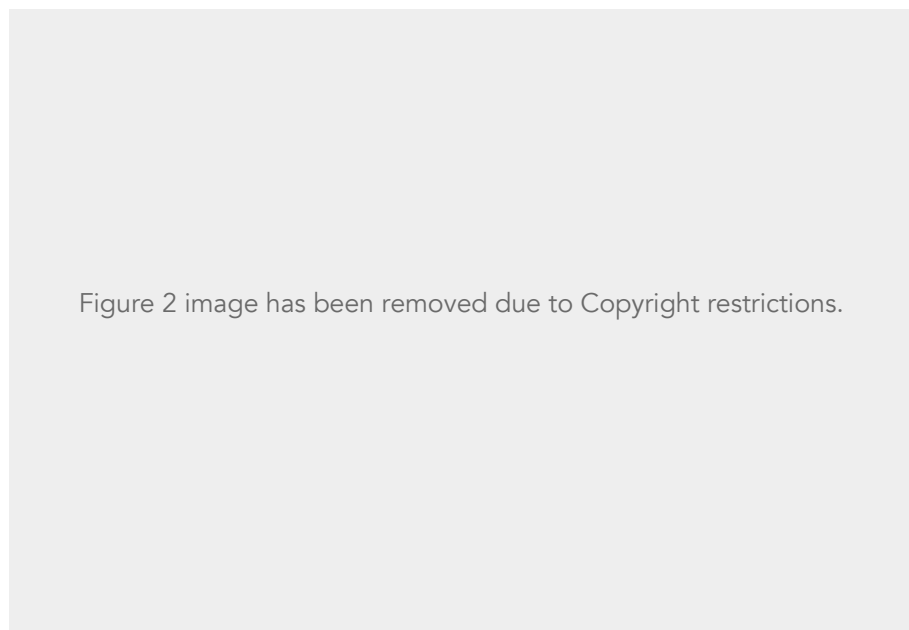

Figure 2: *Error 520* (Lefterov, 2014). This screenprint was the first result that came up when I was searching for keywords printmaking and error on Google. Image: © Saatchi.

Following the approach that error is beyond something simply in need of putting right, it can be shown to create a breakdown in communication (Fig. 2). Yet, this collapse signifies both deconstruction and reconstruction. In terms of

accuracy, the errant process of collapse and repair reveals a new truth and knowledge; error thus instigates renewal. It does not provide resolution. This productive and adaptable interpretation of error begins to undermine oppositions of true and false, correct and incorrect. Error is something fluid. It is not contained by categories, topologies or disciplines. It enables us to experience things differently. From both practical and theoretical perspectives, error helps us to dissect how something is constructed and in doing so understand how it works. Consequently, comprehending the fundamental reasons why, and how, an error occurs is productive for my research. This is explained below from an informational perspective, through providing an account of why error emerges when communication breaks down.

### *Error and information loss*

Discussing error in terms of digital information, and specifically information theory, provides a framework for further analysis, as it delineates the relationship between error and post-digital print. Whilst the specifics of digital information are not the focus of this research and are beyond the reach of this thesis, briefly setting out the genealogy of digital communication provides a foundation for how and why error occurs in this context.

In their 1948 article, *The Mathematical Theory of Communication*, Claude Shannon and Warren Weaver outline the conditions and transmission of information, and attempt to determine the amount of information in a message, or its transmission (Fig. 3). They define how the transfer of information incorporates optimisation and, notably for this research, information loss, both of which are interesting in terms of why an error occurs and what is happening when it does.

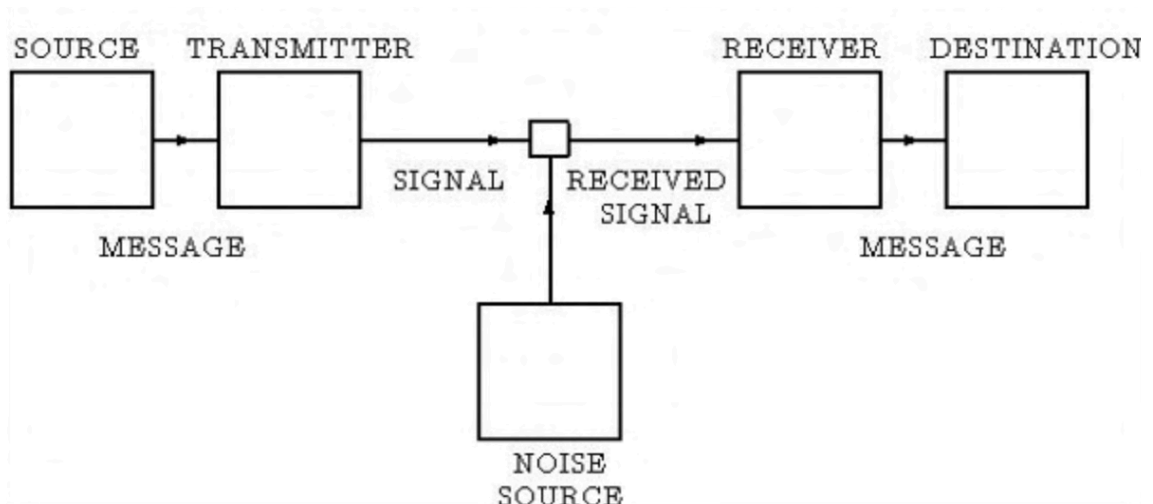

Figure 3: *Model of Communication* (Shannon and Weaver, 1948, p. 381). Diagram capturing the transmission of information.

The diagram reminds me of the loss of information when material knowledge is passed from one surface to another in print, such as attempting to transfer an image from screen to paper in screenprint, eliciting the question: How do you send a message from one place to the next without it disintegrating? In

response to this question, information theory examines optimisation against information loss. Whilst the focus is on avoiding loss of information and how communication should be error free, Shannon and Weaver's optimisation is of value in terms of analogue or digital printmaking error, as when you print something there is always some form of image degradation. This defines information loss in broad terms.<sup>1</sup> Semiotician and writer Umberto Eco (1989) delves deeper into the way we communicate information in *The Open Work*, making connections between information theory and aesthetics. By way of example, Eco neatly describes information loss as the difference between shouting across a river and what can be heard on the other side (1989, p. 51).

Although in information theory error is regarded as something to evade, it is a creative space in artistic practice. Returning once more to Williams's intersection of page, error, and reader (1989, p. 159), and considering Eco's voice which loses distinction while travelling over the river, as well as Shannon and Weaver's diagram, it can be surmised that errors occur where information is lost between artist (noise source), paper (destination), and print matrix

---

<sup>1</sup> For more on how Shannon and Weaver's theory of redundancy provides a practical explanation of what happens during repetition when there is information loss see: *The Mathematical Theory of Communication*, by Claude Shannon and Warren Weaver, (1948).

(source); that is, at the intersection of these.<sup>2</sup> Looked at in this way, error begins to take on a form of materiality (which will be discussed in more detail in section 1.3) and goes some way towards providing an explanation of the way it occurs in printmaking. To support this discussion on why error is important in the context of print, the history of error in printmaking is discussed below, as this can be seen to shape the narrative of print error.

---

<sup>2</sup> My project *Reading Enchiridion* offers a good example of this, where instructions are repeatedly read aloud with each copy differing from the previous one (see Project Description 2 in the User Guide). Likewise, in my project *Plymouth Whispers* (see Appendices) loss of information drives the practice as a text is repeated between groups of people.

## 1.1 History of printmaking and its expanded field



Figure 4: *Enriched Bread* (Kent, 1965), screenprint created using hand cut stencils. Image: © Estate of Corita Kent.

Printmaking is not a predictable or certain set of procedures. Woodcuts, screenprints, dot matrix, and typewriters all resist precision. The lack of accuracy demonstrates the presence of the printmaker to an extent (Fig. 4). There is a tension between the exercise of control and lack of control in, for example, screenprinted stencils that are hand drawn and not rendered through

digital software, or woodcuts which challenge precision and exert their own agency.<sup>3</sup> As such, error is an ongoing consideration in printmaking.

Errors occur at different scales (from minor or tiny *boo-boos*, to important or major catastrophes) and in various types (Fig. 5). In printmaking, errors are commonly recognised as a smudge, poor registration, an ink bleed, or an under-etched image. Errors in print are commonly superficial, but also clearly definable, black or white, present or not present, and associated with a need for fixing, repair or removal rather than embedded at a deeper level. Making decisions about which types of errors are acceptable, and those that are not, is part of the process of being an artist and something that I have many years of experience in (Fig. 6). Consequently, these considerations form a fundamental part of my practice which includes, for instance, choosing to accept a print from an unevenly inked woodblock that reveals its pitted natural wood grain and which might be considered more *successful* than the anticipated solid errorless black. Indeed, I have rejected *perfect* prints on grounds of being of less interest. The print-based artist ultimately chooses whether the print error is

---

<sup>3</sup> The logic of this also applies to the diagrams that are part of this submission, which are not rendered through visualisation software but are hand drawn.

worth pursuing, or whether it would be better to abandon the project and start afresh.

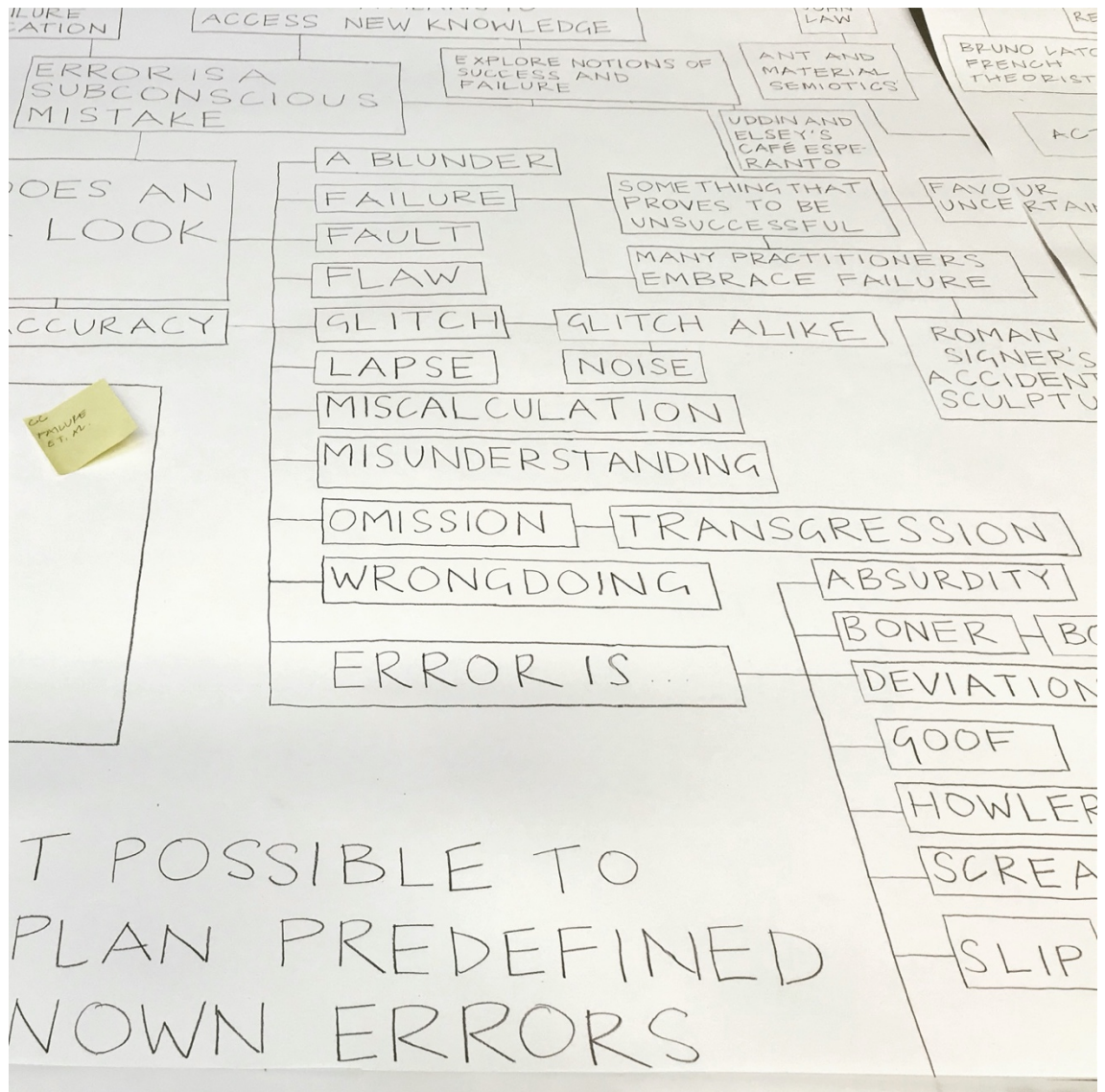

Figure 5: *Error* (Rosser, 2018). Detail of a hand-rendered diagram, exhibited at Prawo Serri: The Agency of Error, StrefArt Gallery, Tychy, Poland.

To understand the shift in the appreciation of error necessitates a discussion on what constituted an error in print from early examples in China, to the Printing



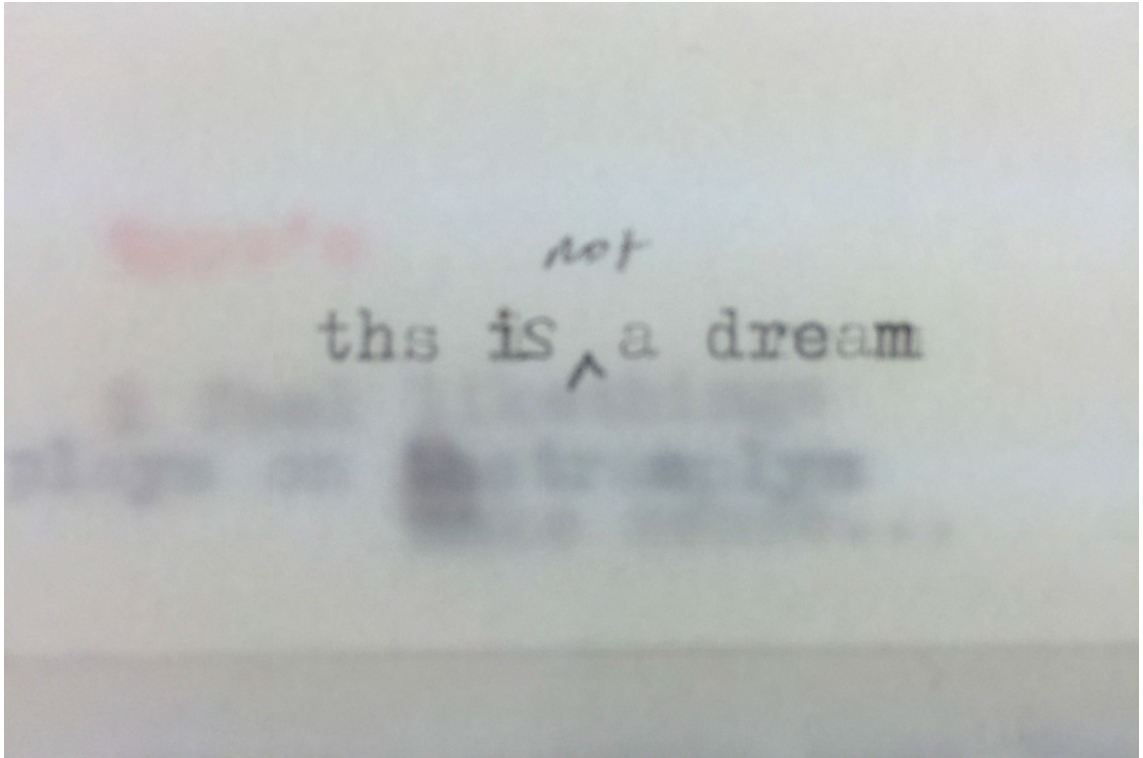

Figure 6: *No one knows where I am* (Rosser, 2015). Slide created from typewritten texts produced for a project (no.1 of 50 slides).

Revolution in Europe, and through to the digital era. Print technologies are of course located in very particular historical frameworks and I will briefly sketch some of the key developments. The first examples were created using wooden stamps in China circa 3000BCE. Woodblock printing remained prominent in China, and during the ninth century the *Diamond Sutra* (868CE) was created, which was believed to be the first printed book (Fig. 7). These early prints were created using relief processes and were predominantly decorative images and designs that were duplicated by carving into wood, stone, or metal and hand-printed in small editions.



Figure 7: *Diamond Sūtra* (868CE). Detail of relief printed Buddhist sutras.

Whilst there is some uncertainty about when print was first used as an art form, various printmaking forms continued to emerge throughout history, such as rubbings in China circa 100CE, woodblock in Egypt circa 500CE, and engravings and woodcut printing in Europe circa 1300. Print emerged in Europe during the 14th century when paper became cheaper and more available. In 1440, the German blacksmith and printer, Johannes Gutenberg

invented a press that used movable metal type (Fig. 8). However, in 1377, a Korean Buddhist document written by the monk Baegun (Buddhist name Gyeonghan), was printed during the Goryeo Dynasty. This is now believed to be the first book printed from movable metal type.<sup>4</sup> The press allowed the mass production of text, religious images, newspapers, maps, and books.

The first Gutenberg Bible was printed in 1455, in what was considered at the time as a relatively large edition of 180 copies. This number may seem tiny today, but at the time of printing there were estimated to be only around 30,000 books in the whole of Europe. The Gutenberg press transformed printing and was used throughout Europe into the 20th century, starting the Printing Revolution and profoundly impacted the transmission and sharing of knowledge. The extent of its impact was such that the printing press revolutionised trade and the economy, society, politics, and culture.

Gutenberg's press enabled information to be disseminated efficiently, and there was growing intolerance for mechanical or human printing errors, which could disrupt aspirations of accurate supplying of information. The printing press was pivotal to the Renaissance period, not only generating cheap and

---

<sup>4</sup> UNESCO certified Jikji as the 'oldest movable metal type printing evidence' (Jones, 2019).



Figure 8: *The Caxton Celebration – William Caxton showing specimens of his printing to King Edward IV and his Queen* (Small, 1877).

fast methods of learning, but creating an upsurge in the distribution of new ideas. This gave rise to a period of artistic, economic, and political rebirth following the middle ages, with an increase in humanist philosophy and a belief in the agency of the individual and the self. Furthermore, and relevant to my own relationship with error, the Renaissance set out a hostility to craft. At the time, it was thought that if an individual was a genius, their work would be worth far more for being unteachable – whereas skills and crafts could be taught. The emphasis was on scholarly, experience, thinking, and the

conceptual act, and building the image through thought and the mind, not the body. Chance and accident, seemingly related to the body, were emphasised in the academy through discussion, contemplation, and inactivity. Members of guilds or craftspeople, however, were encouraged not to make mistakes. As such, they became risk adverse and uncomfortable with error.<sup>5</sup>

During the Renaissance, demand for trade increased, leading eventually to the advent of the Industrial Revolution and, specifically, an industrial age of printing where goods were produced by machines to reduce human labour and increase accuracy and speed. The Industrial Revolution in turn shaped Modernism and the development of industrial societies. Modernists believed in progress and an almost utopian view of life and society. Printing errors were not part of this idealistic vision, rather they represented industrial failure and societal regression of sorts. This context accounts for a deeply embedded

---

<sup>5</sup> During a research seminar in 2018 at the University of Plymouth, the artist and writer Dave Beech discussed the dichotomy of art and labour which provided me with a spark of realisation as to why error matters to printmakers and, in doing so, helped to determine the origins of my own relationship with error. Whilst Beech's research centres on Marxist philosophy, which is outside of the focus of this thesis, it highlights the embedded focus in print workshops on *how* something is created, rather than *why*. This historic friction has endured (to a lesser degree) between artists working in the studio (academy) and artists working in the printmaking workshop (guild) (Beech, 2018). This instigated a key moment of realisation about my own approach to error in my practice and relates to my complex relationship with printmaking error and unease at handing over control.

ambition for accuracy and turbulent relationship with error in print, which was juxtaposed against ideas of societal progression and industrial advancement.

The printing press was succeeded in the 1990s by digital communication, which became widespread during the subsequent Digital Revolution. This period saw the shift from mechanical and analogue to digital and electronic. Regardless of the pervasiveness of the digital era, and the promise of the paperless office, print persists. Printmaking's prevalence throughout the digital revolution contributes to print being *technological*, but in a particular sense. Print is technical, in that there are techniques or processes behind it, but it is consistent with the technological through its cultural, industrial, and informational history. Notably, print is about far more than an outdated mode of reproductive history and is entrenched in society, culture, and politics.

Although they did not form part of the aspiration of the Printing Revolution, errors in print have emerged as an artistic opportunity. This approach to error is reflected in expanded print-based practices, and this is the artistic field where my research will be of primary relevance.

### *The expanded field of printmaking*

In 2015, Jan Pettersson, professor in printmaking and drawing, led a conference and subsequent publication of the same name, *Printmaking in the Expanded Field* (2015), which co-opted the title of Rosalind Krauss's essay *Sculpture in the Expanded Field* (1979) as a departure point to discuss the state of printmaking and its future. Krauss's seminal text interrogated sculptural practice by arguing that it covered a broad heterogeneity of fields in the late 1970s:

Over the last ten years rather surprising things have come to be called sculpture: narrow corridors with TV monitors at the ends; large photographs documenting country hikes; mirrors placed at strange angles in ordinary rooms; temporary lines cut into the floor of the desert. Nothing, it would seem, could possibly give to such a motley of effort the right to lay claim to whatever one might mean by the category of sculpture. Unless, that is, the category can be made to become almost infinitely malleable (Krauss, 1979, p. 30).

Krauss responded by diagramming oppositions between, what she deemed at the time, the irregular combinations of practices, areas of sculpture, and art and architecture among others. In doing so, she identified an expansion of disciplines by bridging contradictory terms such as landscape or not landscape, where the opposition still reflected the original position and yet allowed for new discussions and perspectives. The extensive qualities of the diagram itself were significant in emphasising the *expanded* characteristics of the field. Her

attempts at mapping the changes in the topography of artistic practice more broadly blurred distinctions between artistic disciplines – which has been accepted as commonplace since the 1990s (Fig. 9). Krauss’s legacy is helping artists’ attention ‘to focus on the outer limits of those terms of *exclusion*’ (Krauss, 1985, p. 283: My emphasis added). As artists we tend to revolt against distinctions and categories, and my research arises from this very premise.

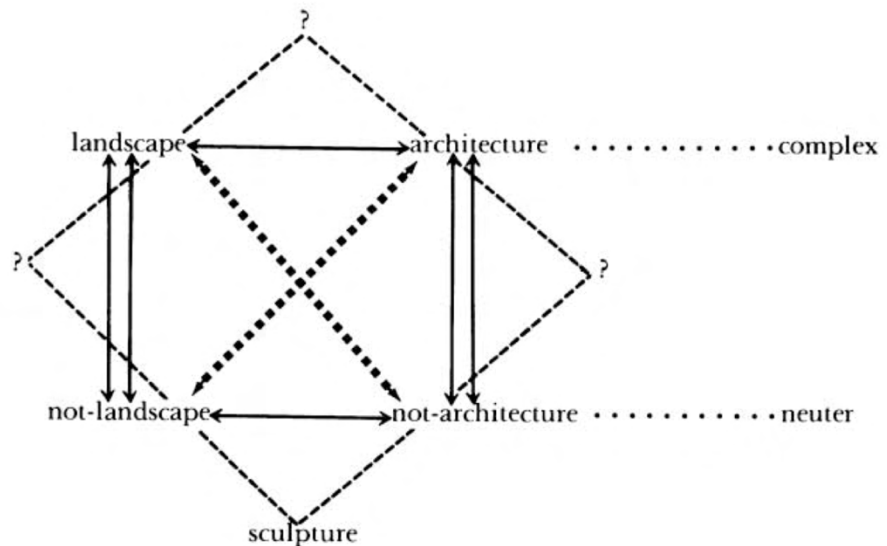

Figure 9: Rosalind Krauss’s diagram of the expanded field (1979, p. 37).

At the same time, there were limitations to the reach of Krauss’s attempt to recount the new ways in which artists were working and thinking. Her expanded field of sculpture reflected a logical space – resembling a computation or mechanical flow diagram – that she believed captured areas ‘in



opposition within a cultural situation' (1979, p. 43). Krauss's rigid and formulaic response was therefore problematic (even in the 1970s), considering her use of terms such as *exclusion*, and her proposal that decisions are based on clean logic and not an uncertain sense of artistic adventure. This is even more problematic now in terms of the influence and potential of our global artistic community, interdisciplinary thinking, and approaches to practice. Pettersson complicates Krauss's diagram by creating alternative intricate print-based versions, adding additional terms of potential opposition which span between



Figure 10 image has been removed due to Copyright restrictions.

Figure 10: *Printmaking in the Expanded Field* (Pettersson, 2015, p. 278–279), is an adaptation of Rosalind Krauss's diagram of the Expanded Field.

circumstance, concept, and artistic intuition (Pettersson, 2015, p. 280) (Fig. 10). In doing so, he positions reproduction as counter to ideas of originality, raising the question whether a print-based experiment can explore ideas and acts of *reproduction* and simultaneously create *unique* prints, concepts, or actions?

In speaking of the expanded field of printmaking, I am making reference to a practice where print has transformative capabilities to move freely and explore the edges and, to borrow Krauss's words, the 'outer limits' of the field (1979, p. 37). The expanded approach, I propose, operates diagrammatically with print processes and thinking as a system of lines cutting across artistic disciplines. Such an approach to practice is wide-ranging and inclusive, and favours fringes and extremities. Print is innately expansive because of its histories of distribution of information – from the Printing Revolution and the guild to digitisation and beyond. As Pettersson declares, 'Historically, printmaking has been characterized by innovation, invention, and technological development; an on-going process that is still present' (2015, p. 19). For these reasons, print in the expanded field is especially averse to containment or limitation, calling instead on the unexpected and following one's instinct. Art historian Susan Tallman maintains that print pervades and traverses concept, intuition, and circumstances (Tallman, cited in Pettersson, 2015, p. 280). This goes against the rigidity of Krauss's diagram which does not leave space, nor has the

flexibility, for error or the unknown. Advancing beyond Krauss's proposition, Tallman goes some way to capturing the essence of the expanded field

in which print is everywhere and nowhere. One could argue that printmaking, now as ever, is a kind of traveling salesman making the rounds of everybody else's expanded field—painting, sculpture, film, installation. Or we could say that print actually owns the ground on which all these expanded fields lie (Tallman, quoted in Pettersson, 2015, p. 276).

Whilst this last sentence is problematic in that staking ownership creates a hierarchy and goes against the inclusivity of the expansive field of practice that I have encountered, I equate Pettersson's notion of the expanded field with Tallman's magpie-esque definition, formed from a practice of exchanging, collecting, and borrowing. Print's association with sharing knowledge and conveyance of information promotes generosity and sociability. The expanded field of print adds impetus to these inherent characteristics, and is unbounded and spreads into unexpected space-places. Pettersson proposes a more forward-facing space, able to respond to contemporary conditions not often associated with print (2015, p. 19). Who knows what this expanded practice will look like in ten or one hundred years?

By thinking about printmaking in this way, one can foresee how there is an uprise in conceptual print-based research, with many print-based artists and texts promoting radical change while attempting to break down traditions

(something I will return to in Chapter 3). Ruptures and revolutions in print contribute to this discussion through re-imagining print and asking: What if, what now and, importantly, what next?

## 1.2 Post-digital printmaking

The previous section established that many printmakers nowadays are thinking differently and rejecting conventions, which provides a foundation for the following discussion on post-digital printmaking, a specific field of expanded printmaking that allows for a reappraisal of our relationship with technology.

This section opens with a discussion on the broader concept of the post-digital and how artists are using error in digital technology as a productive disruption.

### *What is the post-digital?*

Musician and theorist Kim Cascone coined the term *post-digital* in his 2000 essay *The Aesthetics of Failure: "Post-Digital" Tendencies in Contemporary Computer Music*, in response to how artists – digital musicians, in particular – used failure as a creative tool in contemporary music. Cascone declared that ‘the revolutionary period of the digital information age has surely passed’ (2000, p. 12) and, as a result, artists were no longer fascinated by digital technology and its advancement. A network of artists emerged using failing



Figure 11: *Vernacular of File Formats* (Menkman, 2009–2010). One of a series of digital glitch experiments. Image: © Rosa Menkman. Permission granted by Rosa Menkman.

technologies to explore, as media artist and theorist Ian Andrews defined, a post-digital aesthetic (2002) exemplified by the likes of Rosa Menkman (2010) (Fig. 11). This became a prominent practice in the arts with a rise in glitch culture, activating such terms as *glitch-alike* and *pure glitch* (Moradi, 2004), *glitch-feminism* (Russell, 2013), and generating a rise in digital malfunction-based practices exploring distortion (Paik, 2017), noise (Menkman, 2011), and scratches (Nunes, 2011). These mechanical *failures* are all forms of *error*, and this relationship is examined in Chapter 4. This evidences how artists started to make decisions based on a machine's propensity for producing errors such as

glitches, rather than its newness, speed, or latest model. While the post-digital and glitch were regarded as the same for Cascone, this term has grown to encompass more.

Media theorist Florian Cramer has made notable contributions to the post-digital field and provides a stimulating and persuasive account of how artists are engaging in new relationships with digitality. He proposes we rethink technological re-functioning in post-digital spaces in his enticing text, *What Is "Post-digital"?* (2014), where he illustrates the (alleged) rift between analogue and digital, and between digital and post-digital cultures. Referring to a meme, entitled *You're not a real hipster – until you take your typewriter to the park* (Fig. 12), Cramer draws on the complex relationship between an imageboard meme and a man using a typewriter on a park bench (2014, p. 11). The typewriter is depicted as the opposite of the digital imageboard meme (reminiscent of Krauss's *oppositions* within bounded artistic fields). Considering this encounter more closely, the typewriter is a perfect example of what Cramer means by the term *post-digital*. It transpired the *hipster* was in fact a writer called The Awl who offered a storytelling service from a bench in the park. Using a typewriter was the best solution when writing outside with no electricity and limited battery power for a laptop or printer, and where

Figure 12 image has been removed due to Copyright restrictions.

Figure 12: *You're not a real hipster – until you take your typewriter to the park* (2013). A meme Florian Cramer refers to in his 2014 text.

handwriting does not afford the professionalism of physical type. He had repurposed the old typewriter as a small portable press by locating it in a physical, rather than virtual, community context, where people were invited to pay what they liked for his service. Cramer explains how The Awl 'applies a "new media" sensibility to his use of "old media" user customised products,

created in a social environment, with a “donate what you can” payment model’ (2014, p. 24), which he argues turns the community versus mass media division on its head, as the mechanical typewriter becomes ‘a community media device’ (Cramer, 2014, p. 24). Furthermore, the influence of the typewriter hipster meme is about far more than imageboard culture, or a tension between digital and post-digital cultures. Taking a typewriter to the park as a practical option demonstrates the hybrid nature of post-digital attitudes to analogue and digital technology.

Cramer’s example of The Awl marks the appropriation of old technologies as a post-digital approach. This method of appropriation has similarities with the field of Media Archaeology (Parikka, 2012), which critically examines neglected or forgotten media through an artistic analysis of the historical layers of media practice. An important difference of the post-digital, however, is its focus on relationality with both digital and analogue systems, irrelevant of historical significances, and instead exploring the artistic potential of misbehaving, erroneous technologies. Post-digital thinking proposes a non-linear approach to our interrelations with technologies, reinforcing my perspective that new does not equate to better. Cramer’s perspective is of particular significance to my research for proposing a rationale that emphasises how post-digital concerns traverse the analogue and digital, the human and machine. Crucially,



Cramer advances that the term post-digital refers to the ways in which new digital devices are not necessarily a logical upgrade and older media such as typewriters can be understood to be post-digital technologies (2014, p. 13; reflected on in Chapter 4). It thus describes an attitude that embraces the technological flaws and errors that are inherent in all media, old and new, undermining distinction. For this research, it usefully points towards the idea of post-digital error.

### *Being digital*

So far, I've established how the post-digital is entangled with the societal and cultural, as well as the technological. Here I will set out what the digital is in terms of digital culture and digitisation.

In 1995, co-founder of the MIT Media Lab Nicholas Negroponte predicted the future of the digital revolution in his seminal book *Being Digital* (1995). He described what the internet and digital technologies could bring to the world, and in doing so envisioned the digital era:

As we interconnect ourselves, many of the values of a nation state will give way to those of both larger and smaller electronic communities. We will socialize in digital neighbourhoods in which physical space will be irrelevant and time will play a different role. Twenty years from now, when you look out of a

window, what you see may be five thousand miles and six time zones away (Negroponte, 1995, p. 7).

Negroponte's vision of the digital future has become a reality. Referring in his text to the year 2015, he explained how 'mass media will be redefined by systems for transmitting and receiving personalised information and entertainment' (1995, p. 6), and how 'the digital planet will look and feel like the head of a pin' (1995, p. 6). Considering wider discussions on the digital world and its cultural effects, the ubiquity of digital technology has reshaped institutions – particularly in the Covid-19 era – including the perceived relevance of printmaking in art departments.<sup>6</sup>

This reshaping has been furthered by the emergence of what Prensky has called 'digital natives' (Prensky, 2001).<sup>7</sup> Prensky describes a generation of artists, and students, who were born in the digital age – i.e. 1980 onwards – who have a very different relationship with technology from those who have acquired familiarity with digital systems as an adult. Prensky's digital natives have been further distinguished by the psychologists on internet addiction,

---

<sup>6</sup> Many universities closed printmaking departments in the mid 1990s, around the implementation and rise of digital media programmes and practices. This was somewhat precipitate and responding to programme (and student) needs as they failed to predict the peak or continued interest in analogue after the introduction of the digital.

<sup>7</sup> *Digital natives* is a term supposedly coined by Marc Prensky in 2001. Prensky also refers to *digital immigrants* (which allegedly includes myself) in his article *On the Horizon* (2001).

Ofer Zur and Azzia Walker, as either avoiders, minimalists, or enthusiastic participants (2011). The avoiders, they maintain, do not depend on technology, and instead use the tool most suitable for their specific need and are far more interested in being human than being digital.

I suspect this penetration, and normalisation, of digitalisation may have exceeded Negroponte's expectations in its effects on the social, cultural, and political spheres. With digital infrastructures now, directly or indirectly, a part of everyday life for most people in the West, it is not surprising that it is hard to evade its impact on the way we encounter the world.<sup>8</sup> The pervasiveness of the digital continues to reform artistic practice, as well as the tools and mediums through which artists express themselves. One can argue, along with the philosopher Bruno Latour, that being digital is more an ethos, a concept which I analyse in 1.3 as a cultural condition rather than a process or technology (Latour, 2014). With this in mind, it could be proposed that the computer is more than a tool, and to be digital is to participate in various modes of communication, being, practice, aesthetics, and knowledge. This is a period

---

<sup>8</sup> Although relationships with technology are very different for the majority world. Artist Tegan Bristow offers insight into the globalised technology culture and its futures in relation to regions in Africa (2018), which is somewhat at odds with the privileged attitude of the post-digital.

where we are increasingly in tune with digital media, where being digital is less of a somatic or material thing in the traditional physical sense. In addition to facile digital definitions, pertaining to data and series of digits, the digital is capable of being an attitude. It is repositioned outside the discussion of the computer, and rather it can be regarded as a systematic way of being, of thinking.

A consequence of this expanded idea of the digital is an indifference to classifications and an acceptance that the effects of a digital system are more complex and profound than people might think. *Digitality* – a term coined by Negroponte – is now inextricable from the way we live, with our interconnected existence challenging notions of scale, time, society, and being. Such understanding of the digital breaks down distinctions between digital and analogue systems, and inherently also effects printmaking, which I will discuss in detail in Chapter 4 (see 4.2).

### *Differences between digital and analogue*

Formally, digital signals are defined as finite with a limited set of values. In technical terms, digital outputs bear minimal relation to the code that is input, and are divided into countable units. This is in contrast to the description of the analogue as representing data as value on a continuous scale, where the

output is similar to the input. The philosopher Nelson Goodman likewise formally determines the differences between digital and analogue by describing digital signals as 'discrete' and 'differentiated', unlike analogue signals which he claims are 'continuous' and 'dense' (1968, p. 160). Yet the digital is commonly still thought of as an opposite of the analogue. Whilst to *be digital* can be framed as a state of being, as outlined previously, or a technological manner of thinking that can also be applied to the way we read instructions or type discrete letters on a typewriter for example, the same is largely true of analogue. The artist James Charlton captures the allure of the digital based on the following misconceptions:

Indeed the seduction of the digital era was the distinction that it drew in regards to the analogue by offering an enlightenment in which each unit was perfect and infallible – infinitely lossless re/production at all levels. The analogue, by contrast, with its lax attitude to the world was degenerate and impure (Charlton, 2014, p. 3).

In the light of Charlton's distinction, analogue signals are more likely to be affected by noise that reduces their accuracy. Analogue tends not to be efficient nor fast which is alluring for artists, and can arguably best capture error and the imperfections that many artists (myself included) seek. Although its characteristics remain unchanged, the common language used to refer to the digital has evolved beyond discussions of binary logic, which are no longer sufficient to contain the complexities of a digital age that has grappled with

profound societal, political, and economic changes. Digitality is no longer visible or easily distinguishable from analogue tendencies, given how digital information is also imperfect and fallible with terms such as lax, degenerate, and impure becoming ever more present and cogent in its practices.<sup>9</sup>

Returning to more literal understandings, the writer David Sax provides an account of the contemporary role of analogue experiences, framing, for example, writing with a pen and paper as a direct and 'real world [analogue] pleasure' (2016, p. xvii), devoid of the preconceptions and bias of digital software.<sup>10</sup> Although Sax's argument of bias requires further discussion concerning the agency of software, it is useful to add here that writing is also digital, as Cramer alleges, inasmuch as the alphabet is based on discrete units. This reinforces the idea that binary distinctions are not always straightforward nor useful.<sup>11</sup>

---

<sup>9</sup> See Project Description 1.

<sup>10</sup> This aligns with my experiences creating hand-drawn analogue diagrams. The action, or event, of the diagram is signified by the realness and tangibility of drawing.

<sup>11</sup> Arguably the pen and paper can be perceived as portable analogue writing technologies that do not rely on electricity or a battery to function, which might be extended to the human voice in the air or on vinyl, and to noise, temperature, or screenprinting; all of which can be perceived as analogue signals. This is in contrast to wider examples of a digital signals, such as the number of participants at an event, a manual slide projector, or any signals that have been coded and decoded.

Subsequently many things intermingle between analogue and digital processes such as the typewriter or a piano that is digital 'to the degree that its keys implement abstractions of its analogue-continuous strings' (Cramer, 2014, p. 25) (see 4.1.3).



Figure 13: *LetterMpress* (Bonadies Creative Inc., 2017). Screenshot of a virtual letterpress environment app.

Considering Sax's view, with which I broadly concur, the immediacy and tangibility of using a pen and paper offers a connection and

straightforwardness that the digital does not seem to be able to match. However, the choice is not as simplistic as between digital or analogue. Sax refuses to address the details of digitality, and that it is plausible, if not inevitable, that there exists a reciprocal connection between digital and analogue.<sup>12</sup> The opposition between analogue and digital is further problematised when analogue media such as vinyl, cassette tapes, and hand-set type are being transformed into digital representations that supposedly capture the look and feel of the analogue, while maintaining the *practicality* of the digital. An example of this is the *LetterMpress* app which helps to create *authentic* looking letterpress prints using a virtual hand-driven printing press (Fig. 13). This example is indicative of the post-digital practice of repurposing technologies – discussed above with the example of Cramer’s typewriter – yet at the same time it disregards the usability, experience, and cultural implications of working with *old* equipment. Significantly, the concept of the post-digital need not place value on nostalgia, unlike apps such as Instagram, Super8, or LetterMpress, which capitalise on ‘the growing nostalgia for the analogue and fetish of the retro aesthetic’ (Caoduro, 2014, p. 68). Capturing the look and feel digitally only concerns reproducing its material

---

<sup>12</sup> An example of this by Cramer describes the interconnections between an analogue continuous gesture on a touch screen and the binary digital instructions which prompt the processing of information (2014).



effects, overlooking the infinite possibilities, unpredictability, tactility, degeneration, and impurity of analogue, as well as the cultural and societal consequence (Fig. 14 and Fig. 15). Within our digital culture, many things have been digitised as a result of technological developments such as film-based cameras and drawing implements. Social expectations have led to the perception that digital equates with better quality and, in contrast, analogue is identified with unreliability and being unconnected. Alternatively, inkjet prints are often marketed as *original limited prints* or *archival inkjet prints*, implying that somehow they are of a higher value despite their capability of producing limitless digital print runs.<sup>13</sup>

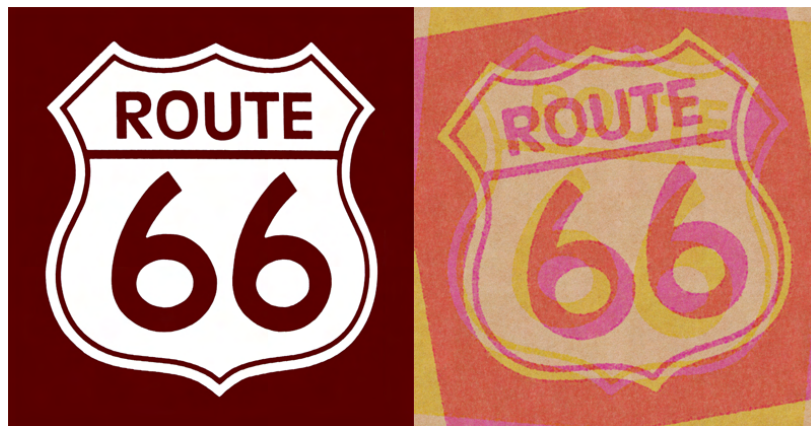

Figure 14: *Route 66* (2019). Screenshot of a filter mimicking silkscreen colour separations with offset layers, using a filter by Mister Retro: Genuine Quality. Original (left), edited (right).

---

<sup>13</sup> Artists Gilbert and George produced an online virtual edition *Planned* (2007), confronting ideas of the limited edition, reproduction, and access to information, as well as the relationship between artist and audience by permitting the public to download as many copies as they liked, and at any size, for a 48 hour period (Higgins, 2007).



Figure 15: Example of an analogue film effect added to a photograph using the app, *Huji Cam* (Manhole Inc., 2019). Screenshot taken from App store.

The supposed rift between analogue and digital cultures, a form of pseudo-competitiveness, deems older or analogue practices as outdated and redundant or burdened with the value of heritage and distinct from the digital era that proceeded it. Drawing on my experiences as a printmaker working mostly with analogue and low-tech digital print equipment, I have faced this competitiveness and the oppositional relationships between digital and analogue.<sup>14</sup> This tendency presents analogue practices as something inferior which requires updating or replacing with *new and improved* digital technologies, rather than its errant prone characteristics demonstrating value in itself. My practice, however, has revealed quite the opposite to be true.

### ***Post does not mean past***

So far we have seen how the concept of the post-digital calls for a rethinking of our connection with technology and how we are using, and thinking, about technologies in new and different ways. Viewed through the perspectives of the earlier discussion on the industrial sense of what error means in the longer timeframe (see 1.1) and this chapter's historical framework setup, the post-

---

<sup>14</sup> On an institutional level, at times it has felt important to fight the corner for printmaking, as it was deemed historical and a creative and cultural underdog, perpetually clawing back from extinction in the shadow of its superior, contemporary, digital relatives. The artist Craig Smith (2016) rightly advised me to stop fighting the cause for print as it is present in my practice, it has its own voice, and the practice will do the fighting.

digital can be defined based on its ability to disrupt linear timelines. A contention with the post-digital is that the *post* in post-digital means *after* or *anti*; however, this does not mean that the digital is historical and has to be remembered with nostalgia (a sentiment which printmaking has been a victim of). Neither is there an implication that we are living in a post-digital age. Instead, it defines more subtle cultural changes and continuing transformations.

The digital age is not a thing of the past. Although digitisation has already happened, as the media art theorist Geoff Cox advocates, it demands perpetual reshaping in different contexts, directions, and speeds (2014). Digital technological development shows no sign of ceasing, with computerisation becoming further embedded in society – such as the wider use of facial recognition software, or increased personal and professional time spent in online spaces due to the Covid-19 lockdowns. Cultural theorist Ryan Bishop and his co-writers describe how this discord is born out of ‘grasping the repetitions and variations of historical trajectories’ (Bishop *et al.*, 2016, p. 22). This leads us to misinterpret the *post* in post-digital similarly to its alternative historical use in, for example, postmodernism. Other comparable uses of the *post* prefix include: post-media, post-internet, post-feminism, post-discipline,

and post-Snowden.<sup>15</sup> Cramer's example is post-punk which he describes as a 'continuation of punk culture in ways which are somehow still punk, yet also beyond punk' (Cramer, 2014, p. 14). This translates neatly to the post-digital condition, where we are somehow still *digital*, yet also beyond *digital*.

Post-digital conditions reflect some of the ways in which analogue and digital are enmeshed and how crude distinctions, or quasi-chronological competitiveness, are misplaced – creating an elaborate network of time-space-place that considers future and past histories. The post-digital focus is on indifference, notably a productive manner of indifference. A post-digital attitude consists of using the most suitable technology for the task, regardless of its newness, or oldness, or cultural stature. This is a school of thought where artists (and in society more broadly) are engaging in new and old, digital and analogue technologies, as a way of investigating and shifting the debate from technological progress to 'developing ways to grasp and intervene in this infrastructural formation of reality' (Bishop *et al.*, 2016, p. 12). Although this is a perspective that is distanced from the digital in terms of its temporality and

---

<sup>15</sup> For more on this, see: post-media (Ludovico, 2012), post-internet (Kholeif and Whitechapel Art Gallery, 2016), post-feminism (Jones, 2003), post-discipline (Wolmark, 2004), post-Snowden (Bishop *et al.*, 2016, p. 17) and post-punk (Cramer, 2014).

criticality, it is in part still defined by the digital in the sense that it is informed by what we have learnt from being digital.

Bishop and others emphasise that the post-digital is not a perspective that pursues determinism by imagining narratives of progress or renewal, which the editors posit as an institutional trap (2016, p. 41). The post-digital thus rejects determinist ideals, where things, methods, or thought processes are determined by previous events. In addition, such approaches challenge agency, as they imply that humans and nonhumans are governed by preceding events, occluding choice and free will. Artists are seeking unknown histories and futures, rather than following narratives based on accepted historical events. As with the contemporary, the post-digital incorporates an ongoingness.

To summarise, post-digital perspectives should not prioritise conversations on chronology or linearity, and should not distinguish by newness. Typically, the post-digital use of *post* raises questions about digital culture and certain questions about histories and the retrospective effects of history within the present (Cox, 2014, p. 71). Despite misconceptions, artists pursuing a post-digital sensibility are not interested in the inevitable chronology of informational and print histories, or consecutive shifts in technology. They are

rather engaging in debates that shift attitudes from temporal approaches to the digital, while using the post-digital framework to contextualise and change the direction of the discourse. This set of ideas is a call for us to 'rethink the digital in relation to its historicity' (Berry and Dieter, 2015, p. 45). In this research, I draw on this conception in relation to print-based practices, where printmaking histories come into play when negotiating projects that traverse spaces and systems, adopting the premise that 'post-digital thinking and production serves as a kind of violence against chronological time and its various medial representations' (Bishop *et al.*, 2016, p. 16). This repositioning is introduced below from the perspective of printmaking.

### *Printmaking and the post-digital*

Post-digital printmaking, as discussed, denotes an artistic approach that is neither interested in chronological modes of technological progress, nor nostalgic for historical print practices and techniques or tradition. To define the shift between traditional modes of printmaking and post-digital print, I draw on the artist and media critic Alessandro Ludovico's book *Post Digital Print: The Mutation of Publishing Since 1894* (2012), in which he argues how print-based artists no longer suppress flaws and mistakes, which can be observed when a slip, crease, noise, and offset mark emerges as a prominent aesthetic. This observation supports the idea that post-digital print has shifted attention from

foreground to background (Cascone, 2000, p. 13), changing from a superficial process-led focus, two dimensional qualities, and faultless reproduction to a concern for mechanical, social or cultural imperfections, failures, and differences.<sup>16</sup>

Significantly, Ludovico's text defines how technology provides an additional perspective on our relationship with print. This is illustrated by the way post-digital print is resistant to *automation* (as will be explored in detail in Chapter 6), a phenomenon, which as the media philosopher Beatriz Fazi declares in her book *Contingent Computation, is consuming the world* (2018, p. 47). In a review of Fazi's text, critic Dominic Fox discusses automation and the deterministic characteristics of computation. He makes reference to the television programme *Doctor Who* and the Fourth Doctor who remarked in 1974, "'the trouble with computers" .... is that they do exactly what you tell them to do' (2019) – unlike print which, analogue or digital, resists behaving in this way. Error is instead an active agent in post-digital print practices, where it is capable of mediating between artist and process. Error is thus understood differently as an outcome of post-digitality. Ideas of the post-digital lay claim

---

<sup>16</sup> From this point onwards, I adopt the phrase *post-digital print* to capture the shift in appreciation of error.



for how error exists beyond binary or digital interpretations. I extend this discussion to create a greater distance from how error is generally understood in digital culture, where it is commonly perceived as an absolute and pejorative term. What interests me is how we conceive of post-digital print errors and how we can explore their creative potential, which is inadequately addressed in current print discourse. This is the ground of my research and the problem I articulate below.

### *Critically addressing error in post-digital print practices and culture*

This chapter has so far set out the fundamental advancements in the printmaking field, and how print-based artists are engaged in rigorous and creative research which enables these practitioners to think about, and use, errors in print processes and digital techniques in new and experimental ways. However, the knowledge gap I have identified is that the evidence of existing discourse in post-digital print is inadequate. To substantiate my claim, the following discussion gives evidence that there is a concern with error in print practices and culture – and yet a failure to address it critically.

Error is only dealt with as a *problem* in traditional printmaking. Printmakers regard error as a serious issue, but don't tend to deal with it critically. Rather, the concern is about the removal of errors – since they are the bane of



Figure 16: *Dream: Pletikosa* (Poskovic, 2017). Hand printed from laser-cut woodblocks. Image: © Endi Poskovic. Permission granted by Endi Poskovic.

printmakers' lives – rather than critically realising that error is both in-escapable and in a context of digital perfection actually a strength (see 1.1). The problem is that there is a lack of discussion around error in wider printmaking practices beyond its fundamental forms – although error is at least addressed within post-digital contexts.

As this section sets out, error is recognised as positive within post-digital print discourses, but this tends to be in an instrumentalised way (such as where given glitchy, noisy or clunky print techniques provide more stylistic or aesthetic errant possibilities). See, for example, Endi Poskovic's woodcuts (see Fig. 16), or Marta Anna Raczek-Karcz's writing on how artists are exposing print glitches – or technical errors – on print matrices (2017).<sup>17</sup> Both Raczek-Karcz and Poskovo present error as something that is process-led and risk free, in a way that allies with early post-digital discussions and practices (see 1.2). Although such practices use error, they are neither transformative, nor risky. Instead, they are fixed and *glitch-alike* rather than *pure glitches* which are

---

<sup>17</sup> Endi Poskovic and Marta Anna Raczek-Karcz presented their work at the international printmaking conference, *Post-digital printmaking. Redefinition of print*, which took place at the Centre for Innovation at the Academy of Art and Design in Wroclaw from 6th to 8th December 2017. Poskovic provided the keynote for the event. Raczek-Karcz's paper was titled, *Perfection and Glitch: The influence of digital thinking on Polish contemporary printmaking* (2017).

unstable and happen in the moment (Moradi. See information on glitches introduced in 1.2).

Whilst these artists discuss error's ability to foreground materiality in their work, this approach remains strictly within traditional approaches to craft, rather than in recognising the dynamic vibrant agency of error, to matter, or to make a difference, or indeed challenge the assumptions of printmaking traditions.

There is a gap in post-digital print discourse around understanding the true materiality, entanglement, and significance of errors for printmaking, and for culture. In relation to issues that currently exist – where post-digital print tends to treat error as static – my contribution centres on the uncertainty of temporal errors and those that are unstable, such as momentary elements of folding, of video, of over printing, and of networks that offset the stability of print.

### *Scope of the research*

The field of error in post-digital print practices and contexts is vast. It is therefore necessary to recognise the limitations of this research project and to signal where I am not going to explore further.

Despite aspects of labour and exhaustion in the work (of both myself as a printmaker, and the computer printers locked in an eternal loop of exertion),

the research instead prioritises error, its agency, and relations. Methodological decisions were made to not centre on the intersection of my work with labour and exhaustion. Whilst concentrating on these approaches was beyond the scope of this PhD, they present creative and exciting promise for future work (see 8.5). Acknowledging these limitations enables me to prioritise my attention on print-based error, its relationality, and the noise and language of the projects.

Additional decisions were made to avoid focusing on the performance-based elements of my work. I acknowledge the computer printers as *performers* – the architects of the projects – which (per)form and shape the errors. Yet I elected not to look into performance practices and ideas of performativity, as this would muddy my machine-led discourse, creating potential for anthropomorphising both my print equipment and the errors themselves. This would reduce the methodological precision detailed in the following chapter.

### **1.3 Printed matter matters**

Since the post-digital condition suggests that everything is uncertain, can we use error and *printed matter* to talk about more *pressing matters*, rather than concerns for process, histories, or accurate reproduction? Everyday print

technologies, which are embedded with error, are often overlooked; yet they provide openings for insightful experimentation between humans and nonhumans. With this proposition in mind, I examine how error mediates between artist and intention, between human body and machine. That is to say, focusing on error not only provides a different way of encountering printmaking, but also offers insight into these relationships.

My research distinguishes error as an intermediary or arbitrator between artist and print technologies, accuracy and uncertainty, knowing and not knowing. When an error occurs, we realise that we are not solely responsible, nor solely in control of processes. By examining the intricacies of print error, one can expose larger concerns about our relationship with the technologies we use. My practice and this thesis centre on exposing the agency of error, and so agency is a critical term in my research. It is used to capture the way a print error has the ability to exert influence and intervene with the things and beings it comes into contact with as part of a network that includes artistic ideas, processes, culture, and other external influences. Before unpacking this in terms of the nonhuman and its specifics in art practice, it is pertinent to outline common understandings of agency – this will also help lay the foundation to the main discussion in Chapters 6 and 7.

Agency is broadly defined as the capacity of a thing or person to act or exert power, and it can be utilised by both nonhumans and humans. This understanding is useful for my research when exploring how error has the ability to create effect or influence, and ultimately the capacity to change events, communication, and meaning. Agency can therefore be attributed to something that has the potential to act in a network of relationships outside of the physical world (Gell, 1998, p. 17). Moreover, in my research, agency refers to an activity which is not related to intention or cognition. As such, print errors are instinctive and unlearned, and their interactions are unthinking and unpremeditated. In the light of the earlier post-digital discussion (see 1.2), error and technologies can begin to develop their own voices. Outside of the physical world, objects and non-objects such as software, bytes, or a mark on paper exhibit agency within a broader assemblage of relations.

My interpretation of agency is not territorial, nor am I interested in hierarchies. Rather, error as an agent is realised through its relationships and cannot be described separately from its interconnections with other things and beings, especially when it comes to artistic thinking and print technologies. The following discussion sets out how my research project draws on actor–network theory, associated with Bruno Latour, to call attention to how error cannot exist independently of systems. It also draws on new materialist thought, for

instance in the writings of Jane Bennett, for the way in which error is lively and entangled. My research also looks to discussions of the cognitive nonconscious as errors are not capable of conscious thought, to adopt the phrasing of N. Katherine Hayles. By describing error in this way, I seek to undermine divisions between artist and print technologies, where all things are capable of exerting agency.<sup>18</sup> As such my argument that error too has agency is conceivable, even if error is not commonly discussed in this light. Alongside my artistic practice, drawing on the theorists introduced below advances my exploration of the agency of error in post-digital print practices – discussed in more detail in Chapter 6.

### *Actor–networks*

Latour’s actor–network theory provides a framework for considering the way in which objects demonstrate agency through their relationality, and significantly for this research it focuses on the relations, or networks, between humans and technologies (2005, p. 10). By foregrounding the network, Latour transforms the network into a medium in itself, where an object is defined by what it

---

<sup>18</sup> As the boundaries between humans and technology are increasingly blurred (hastened by the Coronavirus lockdowns which increased our virtuality), we have become increasingly *virtual bodies* and information has lost its body (Hayles, 1999). Whilst this aligns with Posthumanist theory (Hayles, 1999), it has resonance with my denotation of agency, as I advance how agency is distributed between bodies and things. Agency is thus not resistant to, or beyond, the human condition.



obtains through its relations, rather than what it is given. Latour describes this as material agency (2005, p. 53). This perspective facilitates an understanding of the materiality of error, and as something that has agency. According to him, objects or things exist in continually shifting networks. This explains how error, in its essence, can span between meaning and nonmeaning, fabricated and factual, digital and analogue contexts (Latour, 2002; Schmidgen, 2012). Latour explores this 'transformation' of information, where through traversing space and time one encounters different results each time (Lovink and Schultz, 1997). This becomes meaningful in the context of this research while analysing errors on a series of prints. When humans and machines come together to form a network, each co-exists and interacts with the other. Latour's discussion of things that 'co-exist' is important in relation to the network of error/printmaking/artist/audience as it helps to distinguish a *co-constituted agency*. This is distinct from more general understandings of agency and will be discussed more fully in Chapter 7.

Furthermore, Latour rejects the specificity of the digital (Latour, 2014).<sup>19</sup> Whilst this claim is somewhat distracting, it undermines digital distinction which

---

<sup>19</sup> Philosophers continue to disagree on the precise definition of *digital* and *analogue*, but it is accepted that a necessary feature of what it means for something to be digital is that of being discrete (Floridi, 2009, pp. 168 - 172).

contributes to the concept of the post-digital. With this in mind, the media theorist David Berry suggests a need to rethink the digital in relation to its historicity (Berry and Dieter, 2015, p. 45). Latour highlights a material relationship between digital and analogue, where analogue structures underpin digital processes and are part of a 'socio-technical environment' (Berry and Dieter, 2015, p. 47). This materiality of technical and human relations consists of complex and fragile agencies/forces, always at work and incomplete.

### ***New materialism***

New materialism furthers the discussion of relational agency by embracing how active materials and bodies cut across living and non-living entities. New materialism champions the productive force and power of things, and this is useful in terms of explaining how error, in its disruptive liveliness, influences aesthetic opportunities. New materialism is in essence a relational ontology that attempts to rethink the division of nature/culture, body/thought, concrete/abstract. This is significant in supporting my rejection of a binary interpretation of error.

The theorist Jane Bennett contributes to the field of new materialism in *Vibrant Matter* (2010a) by disclosing the vibrating energy of things. Significantly, she

does not believe in denying inanimate objects energy or vitality, and considers everything to be lively and entangled, from air to plants, and for my purposes, from error to ink. Bennett attempts to dissolve the distinction between object and subject, helping to demonstrate how error, and the paper on which it is printed, has the capacity to co-create effects.

Bennett acknowledges the unique ontologies of entities and matter, while focusing on what something could be rather than what it is. In my research, this focus on what something *might* be places emphasis on unforeseen potentiality and applies an emergent and unpredictable agency to matter. According to Bennett, things are never entirely stable or passive, and what particularly resonates with my research is her argument that things (or errors) are constantly undergoing transformation. Furthermore, Bennett writes that human encounters with lively matter 'expose a wider distribution of agency' (Bennett, 2010a, p. 122). This suggests how error is capable of dispersing, and receiving, impact within a wider network. Bennett explains the force of this interaction as 'distributive agency' (Goble, 2017, p. 72), which supports my argument that error is capable of a relational form of agency (see Chapter 7).

### *Errors think without thinking*

Of additional interest to the discussion of agency is literary critic and theorist N. Katherine Hayles's *Unthought* (2017) which outlines how cognitive processes, or cognition, apply to human nonconscious thoughts and significantly also to data and technological systems. Hayles's definition of cognition concerns more a broader nonconscious faculty than thoughts associated with higher consciousness, such as rationality. This is useful in terms of understanding how error, within a human and technical assemblage, is capable of cognition (but not cogent thought) and can disrupt rational thought (but not define it). This calls attention to error's ability to influence behaviour and conscious thinking. Notably, Hayles locates these discussions in the arts, providing a framework for theorising how error and technical actors think (without thinking) in artistic practice.

Through this manifestation, error, data, and print machines maintain their own voices, whilst collectively they are capable of disrupting knowledge and instigating not-knowing. Hayles refers to the relationships as *assemblages* as an alternative to Bennett's focus on *entanglements* or Latour's *network*. A more detailed discussion of these terms is not necessary for my argument, but broadly they function as dynamic sites of exchange and transformation. Whilst both entanglements and assemblages have a contiguity in a 'fleshy sense',

touching and mutating (Hayles, 2017, p.118), networks, in contrast, possess clean edges and a materiality (Galloway and Thacker, 2007, p. 22). Yet all three terms are insufficient for capturing the materiality of the interrelationships in print error in my research, creating a gap, an opening, and below I introduce *cross-talk* as an alternative concept.

### *Cross-talk*

There is a *dialogue* between printers, paper, and technologies. The dialogue between the raw material of the practice is the language of the work, consisting of networks, traffic, and tweets. Cross-talk is the term I use to tie these elements together. As a material exchange between humans and machines, cross-talk has a different modality to a language associated with linguistics; an example of the latter exchange is the social media platform Twitter. When Twitter asks, 'what's happening now' (a Twitter tag line), it prompts a human-centred conversation distinct from the machine dialogue I pursue, which broadly asks the same question of ink, paper, and printers (Fig. 17 is an early exploration of these relations). I refer to this machine and print chatter as cross-talk to capture an encounter across platforms, paper, electricity, and so forth. This is distinct from language or discourse which have

strong human associations, and rather it expresses the breaking down of a conversation and thereby the network.<sup>20</sup>

Cross-talk thus refers to noise and leakage across systems (see information theory and information loss introduced earlier in Chapter 1), and applies to ink when dispersing and losing information as a carrier of meaning, but also to its viscous materiality. For example, it is due to ink's particular properties, such as leakage, that many errors arise. Ink bleeds across or through the paper, and leakage is described as accidental admission or escape through a hole or crack (Wark, 2013). These are visualised as ink seeping through paper fibres, or distortion on a pixelated screen, or spilling of information on to the floor. Cross-talk emerges through such an event where the material properties of ink come into dialogue with paper.

The preceding section sets out the system of methods I use in my PhD, while Chapter 2 *diagrams* my methodology and the relations between them in detail.

---

<sup>20</sup> As can be seen in the project *[mis]Feeds* (see User Guide and Chapter 6).

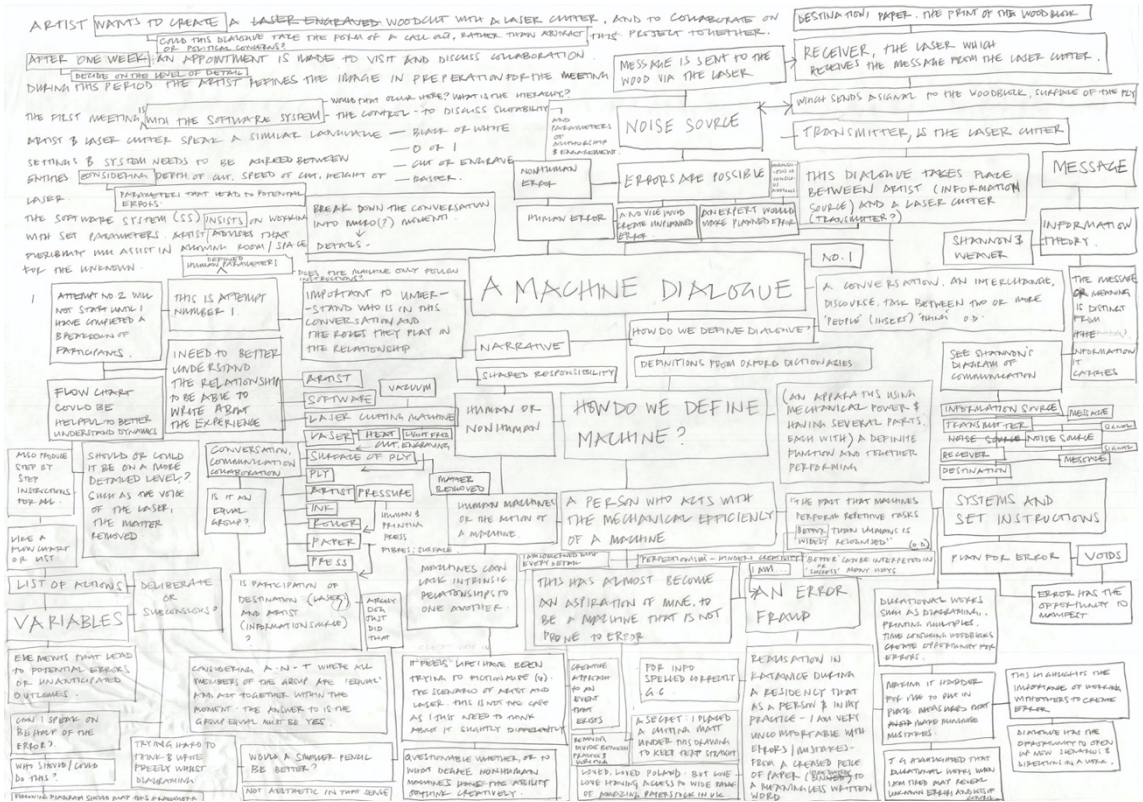

Figure 17: A Machine Dialogue (Rosser, 2018). A diagram exploring the relationship between error and print technologies.

## Chapter 2: Mechanisms of Research

### 2.0 Methodological framework

Diagramming is part of my practice, but also used as a structural device in articulating the relations that are introduced in each chapter and the way the various ideas come together. This section of the chapter, which is in the form of a diagram, maps out my methodological approach and provides an exemplar of how the practice of conceptual diagramming is also a core part of my research strategy. The next section sets out how the functionality of the diagram has been adopted across the PhD.

Figure 18: *Mechanisms of Research* (Rosser, 2021–2). See folded diagram overleaf.



# ARTISTIC PRACTICE

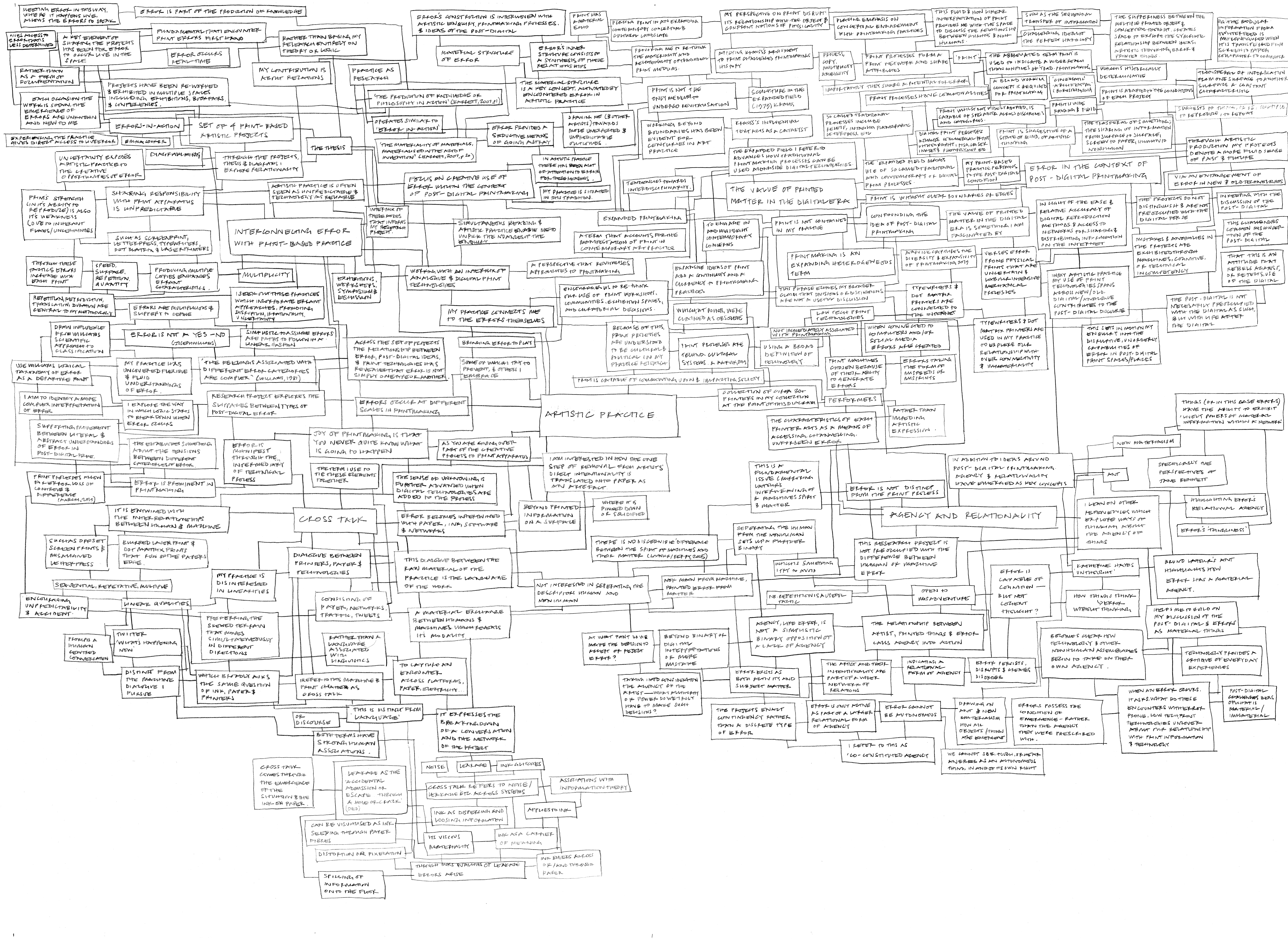

## 2.1 Diagramming relations

A series of diagrams intersect the bodies of text in my thesis, bridging the three main parts and the chapters therein. The diagrams consist of distinct assemblies of information, as a method of both separating and creating relationships between the issues addressed in individual chapters. They perform a functionary role in the construction of the thesis, and I distinguish them as a textual practice, a form of writing. Conversely, I perceive writing as a form of diagramming, a system of structuring my argument throughout the thesis. In *Practice of the Diagrammatic* (2016), theorist and artist Simon O'Sullivan draws on Jacques Lacan's *Écrits* (2006), describing how a text can operate as a diagram which 'like Japanese flowers' needs to be placed in water to unfold (2016, p. 14). O'Sullivan's suggestion of an unfolding of information resembles the way my argument unfolds – both metaphorically and literally – across my diagrams and the constituent parts of the thesis.

Diagramming is a core method I use to map the relational agency of post-digital print error and to elaborate my argument (Fig. 19). It is an artistic practice that sits on the edges of the main discussion and set of projects. As a methodology, it is not just making the diagram that is important to me, but

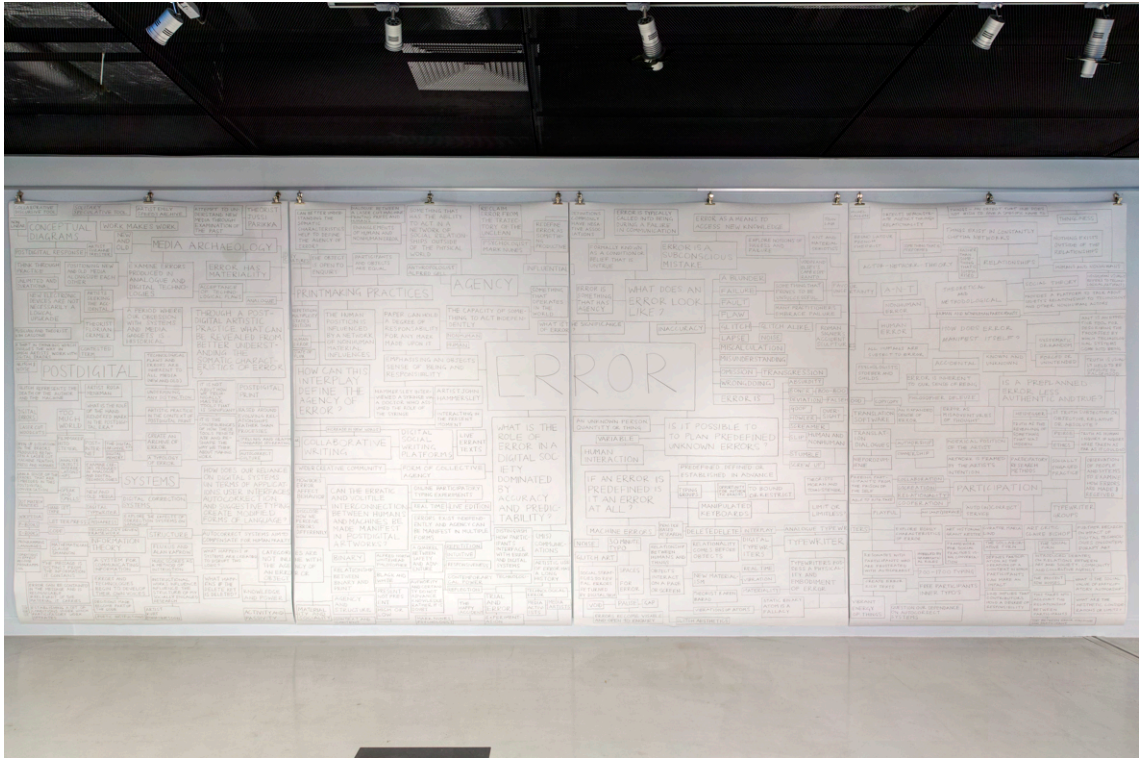

Figure 19: *Error* (Rosser, 2018). A 6m x 2.5m diagram exhibited at *Prawo Serri: The Agency of Error*, TrefArt Gallery, Tychy, Poland.

also thinking with it (Fig. 20). To O’Sullivan, diagramming is an artistic practice in itself (2016, p. 13), and by extension a research practice too. Diagramming error encourages a blurring of distinction between the representational and nonrepresentational field. The Deleuzian interpretation of the diagram as both true and false likewise informs my use of diagrams as exploratory practice. Deleuze posits that the diagram is not a representation of an objective world. Rather, it creates a new type of reality. He complicates the diagramming–reality relationship further by writing: ‘The diagrammatic or abstract machine does not function to represent, even something real, but rather constructs a real that is

yet to come, a new type of reality' (Deleuze and Guattari, 1987, p. 157). This Deleuzian form of reality is congruous with my approach, where my diagramming is both cyclical and constantly recreates itself.

As such my diagrams are speculative and actualise subjective thought on the relationship between my projects, error, and theoretical research. My experience reveals how the diagram can produce knowledge, and how this method operates somewhere between my practice and thesis, linking them together.



Figure 20: *Agency of Error* diagramming performance exploring research mechanisms, during a residency at Academy of Fine Arts in Katowice, Poland (Rosser, 2018).



Figure 21: Sequence of images from *Agency of Error* diagramming performance at Academy of Fine Arts in Katowice, Poland (Rosser, 2018).

The diagrams and set of projects reveal how individual projects sit within a complex networked space. Notably, it is *through* the diagram that I focus on developing insight into the relationships between my projects and error. One might say, drawing on Deleuze, that the diagram sets these thoughts in motion. In doing so, I use diagrams to think in *real time* about jumbled and slippery categories, order, structure, and connections (Fig. 21). Situated more broadly in relation to cognitive maps, my diagrams are ‘lines of thought’ (2014, p. 57) to appropriate a phrase from the artist Mike Kelley. From a Deleuzian perspective, they exceed representation and simultaneously announce a past

and a future.<sup>21</sup> My diagrams exemplify an approach where I only see the relationships and spaces between categories of error and my methodological considerations. This is not a means to tie error down to a specific definition, as I hope has become apparent. Rather, I am interested in opening up the tension between a variety of different interpretations of error.

---

<sup>21</sup> My use of the phrase *lines of thought* draws inspiration from Deleuze's phrase 'line of flight' which he writes of as marking 'the reality of a finite number of dimensions, that the multiplicity effectively fills; the impossibility of supplementary dimension [...] transformed by the line of flight' (1987, p. 9).

## Chapter 3: Survey of the Field

Throughout this research, my practice draws mainly on the work of theorists rather than artists, and yet is practice-led in its approach, even in its eclectic approach to theory. Whilst I am interested and inspired by the work of other artists, I choose to draw on theorists because they inform and clarify the theoretical framing of my practice. Throughout the main discussion in Parts Two and Three, I put up a firewall of sorts between my practice and practices that appear similar to mine. The reason for this is that projects that share similarities with mine can create unwanted noise and potentially cloud my ideas. It is, however, important to contextualise my practice more fully in relation to the work of other artists, and in this chapter I offer a survey of the field of what I am calling *post-digital print*. The survey explores artworks that specifically address concerns about error in print-based practices, and in particular those I perceive to highlight post-digital sensibilities, alongside theoretical texts that inform my artistic thinking. As already mentioned, in discussions of printmaking much of the focus is placed on process and skill. This survey of the practices and concepts of post-digital print (see 3.2) and diagramming (see 3.3) underscores my interest in a more expanded sense of printmaking. I particularly focus on examples that directly inform the practice-based elements of the research as outlined in detail in the User Guide.

Before proceeding to survey the post-digital field, it is necessary to examine error in practice more widely, as a precursor to assessing error through the main core concepts.

### 3.1 Error and artistic practice

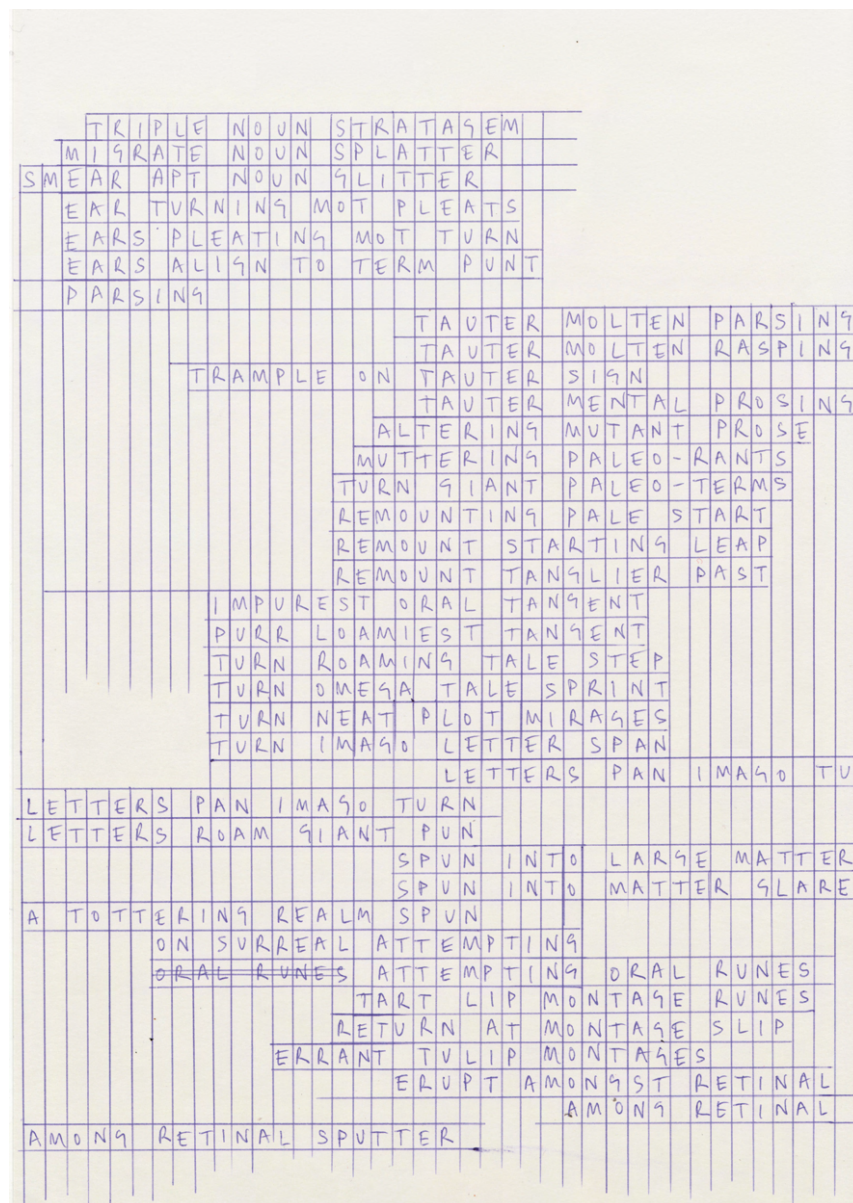

Figure 22: *Triple Noun Stratagem*, (Barham, 2013), biro drawing on paper. Image: © Anna



Barham.

There is a longstanding relationship between artistic practices and error, which is often embraced as potential for unforeseen creativity. Artists have deliberately pursued *wrong* or *uncertain* practices that add to our understanding of error – such as boredom (Jeremy DePrez), silence (Marina Abramović), erasure (Joseph Kosuth) or forgery (Hans Van Meegeren) – to subvert rules, hierarchies, and conventions.<sup>22</sup> Cascone writes of how:

‘poets, painters, and composers [...] throughout the ages [...] have used “devices” such as absinthe, narcotics, or mystical states to help make the jump from merely expanding their perceptual boundaries to hoisting themselves into territories beyond these boundaries. This trend to seek out and explore new territories led to much experimentation in the arts’ (2000, p. 13).

Such examples ‘disclose a field of possibilities, to create “ambiguous” situations open to all sorts of operative choices and interpretations’ (Eco, 1989,

---

<sup>22</sup> Jeremy DePrez embraces boredom by reproducing scribbles from his notebooks. This replication turns a small notebook scribble into a large oil painting. The mindless, unconscious, typically insignificant act of doodling transitions into something monumental and considered through the act of painting (2012-2013).

Marina Abramović explores silence and stillness through her performative practice. In the work, *The Artist is Present* (2010), silence and stillness become a form of communication, a space to negotiate relationships and self-reflection.

Joseph Kosuth’s project on erasure, *Zero & Not* (1986), consists of a Freudian text printed on the gallery wall, struck through with black tape. In this way, the text is erased, but persists and remains readable in a particular way. ‘Its lesson [...] about the impossibility of erasure – simply won’t go away.’ (Dillon, 2014, p. 312).

Art forger Hans van Meegeren fooled the world into believing his fake Vermeers were genuine (Chernick, 2020).

p. 44). These errant practices create an 'openness' (Eco, 1989, p. 44) in which the errors are allowed (or even encouraged) to happen, reflecting the value artists place on uncertainty and taking risks.

It is pertinent here to cite further examples of artists who have typically pursued error, employing similar strategies to mine and, significantly, endorsing the use of key modalities of print such as repetition and translation to generate error, in turn promoting disruption and irrationality. Bruce Nauman's productive use of slips in language and repetition, which instruct the viewer on how to physically behave, shows one way of how instructional texts can be in flux and traverse between rational and irrational thought.

Providing further insight on the use of instruction sets are Anna Barham's drawings from 2013 that make use of slippages in language to explore the potential of unruly words and errant anagrams in seemingly logical and systematic word search puzzles (Fig. 22). The systematic editing used by Sven Augustijnen in his film *Johan and Francois* (2001–2003) likewise highlights mistakes in language by exposing tensions in spoken words through aphasia sufferers' inability to produce or comprehend a text, thereby giving gravitas to stuttering, errant language as something material (Fig. 23). Nauman's, Augustijnen's, and Barham's projects demonstrate how error can creatively



Figure 23: Film still from *Johan and Francois* (Augustijnen, 2001–2003). Image: © Jan Mot.

A celebration of error has been noted in printmaking practice, especially since the beginning of the digital age. As discussed in the opening chapter, the traditionally systematic processes of printmaking have fostered a desire for control and accuracy. But despite this culture of process and order, print methods are also embedded with error and a simultaneous material effect. Printmaking artists have adapted to embrace the material (and immaterial) qualities of error, and the examples below evidence the interactions between artist, machine, and error.

The shift in attitude towards the appreciation of error for print-based artists is apparent in exhibitions such as *Mistakes* (2017), dedicated to printmaking errors. Likewise, print states which document errors created in the proofing

The shift in attitude towards the appreciation of error for print-based artists is apparent in exhibitions such as *Mistakes* (2017), dedicated to printmaking errors. Likewise, print states which document errors created in the proofing



Figure 24: *Materials of Resistance* (Thornton, 2018). Exhibition catalogue, Plymouth Art Centre. Image: © Plymouth Art Centre. Permission granted by City Edition Studio.

process are being exhibited and discussed at printmaking conferences (Raczek-Karcz, 2017).<sup>23</sup> Considering the printmaker's relationship with machines, Elisabeth Tomos uses the print workshop as a performative space to

---

<sup>23</sup> Print 'state' is described as 'A particular stage in the development of a work. Any alteration to the printing surface, after a proof has been taken, involves the creation of a new state' (Lambert, 1983, p. 47).

investigate the unforeseen (2016–2019), and the late artist Clare Thornton explored repetition and falling in her project *Materials of Resistance* (2018) through the relationship between a dancer and the printing press (Fig. 24).<sup>24</sup> These examples are testimony to how print is not confined to accuracy and skill alone. They demonstrate how artists are thinking differently about an expanded field of printmaking by actively seeking the error and loss of control which post-digital practices seem to necessitate.

### 3.2 The field of post-digital print

In this section, I introduce the field of post-digital print in an attempt to provide a framework for the more in-depth discussion on key contributions to post-digital print practices that follows. Introduced in 1.2, Cascone's concept of the post-digital (2000) reflects how artists utilise failing technology to create errors in contemporary computer music. Cramer's argument that post-digital artists favour the misbehaviour of technology nuances this view and necessitates a shift in our thinking and appreciation of the various ways in which artists work with post-digital errors. The idea of the post-digital thus lays

---

<sup>24</sup> Thank you, Clare, for your all-round awesomeness, advice, kindness, creativity, thinking, and dedication to the field of printmaking. I write these words following Clare's deeply sad passing in 2019.

the foundation for a reconsideration of the creative role of error in print-based practices.

Ludovico has made fundamental contributions to the exploration of the rift between analogue and digital, specifically in publishing and print cultures, questioning how paper and pixel can co-exist in post-digital publishing (2012, p. 8). His study attests to how print-based artists are navigating analogue and digital spaces, giving rise to the practice of post-digital print defined by its refusal make firm distinctions between bytes or books.

Post-digital print has been explained by Ludovico as a distinct area of practice. (2012, p. 7). He advocates how this field presents opportunities for error to exist beyond superficial and simplistic digital interpretations (2012, p. 81). Indeed, print can be based on an evolving set of relations rather than predetermined processes. This indicates an important shift for printmaking, placing emphasis on both error and relations in new and old print technology.

Artists Angela Geary and Paul Catanese define this relational territory in their handbook on hybrid printmaking as where new and old technologies intertwine in 'a space of creative action' (2012, p. 8). The print-based artist Paul Laidler's argument resonates with the idea that post-digital print is less process-based and more reliant on relations, upholding that the mastery of tools is less

significant than how technologies penetrate and reshape the way we think about making artwork (2016, p. 61). This is evident in the rise of artists embracing the materiality of errors found in digital and analogue print technologies, reaffirming the efficacy of human/machine relationships and the uncertainty they afford.<sup>25</sup>

I now offer a more in-depth discussion of four artists – Xavier Antin, Hans Haacke, Martin John Callanan, and Dane Mitchell – in order to help substantiate my own practice and open up the imaginative potential of post-digital print. The practices of these four artists are very much aligned with my own and they relate to the key terms defined at the start of this chapter: post-digital print and agency. In the process, I describe some of their key projects and aim to make connections with my own work, followed by a subsequent review of artists that work with diagramming practices.

---

<sup>25</sup> Although focused chiefly on the field of media arts, the Ars Electronica institute drew attention to how error is pivotal to the field of art, technology, and society in their 2019 festival, *The Art of Imperfection*. The festival encouraged a comprehensive dialogue through inviting artists to examine error in the context of *irritation, order, value, and control*; all terms frequently challenged by artists exploring the post-digital condition.

# PRINTING AT HOME

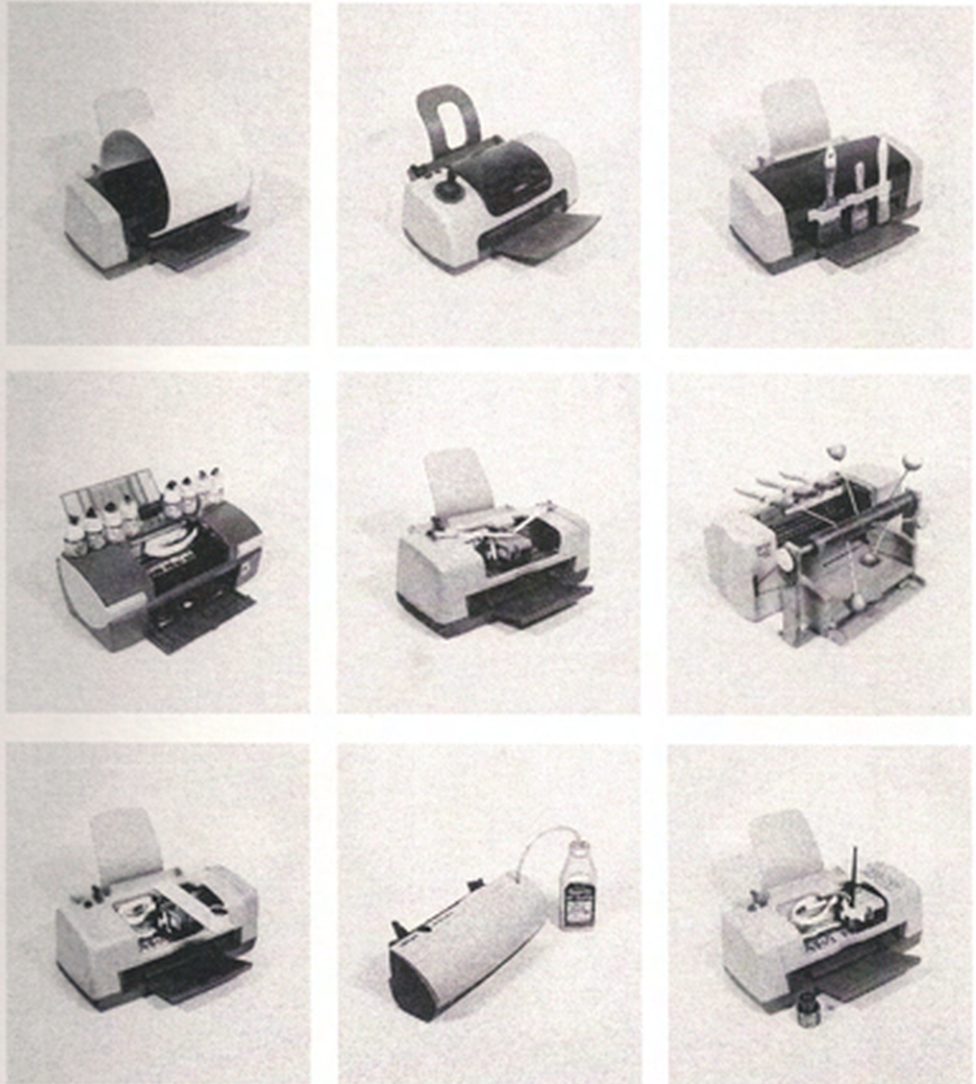

Figure 25: *Printing at Home* (Antin, 2010). Image: © Xavier Antin. Permission granted by Xavier Antin.



First, of particular relevance to this research is the work of artist Xavier Antin who imaginatively examines the malfunctioning of technology, specifically low-tech image reproduction devices such as printers and scanners. This not only bears a close resemblance to my practice, but reappraises the concept of the print workshop and rethinks how old technologies affect the way the work is made (Laidler, 2011, p. 28). For example, Antin's project *Printing at Home* (2010b) takes the form of a printer user manual documenting a series of archaic desktop inkjet printers he has reconfigured, or hacked, to disrupt the printing process (Fig. 25).<sup>26</sup> This evokes Ludovico's suggestion, alluded to above, that we are beyond thinking solely about established uses of print. Antin's hacker's guide also makes reference to false or suspicious information on the internet, congruous with the post-digital where everything is disorderly and to be questioned. In doing so, Antin's work substantiates concerns common with post-digital thinking. In *Eternal Network* (2016), he creates an imagined printing workshop where the printers sit paused, suspended in time, constructing a speculative history of the printing press. The project breaks down time-specific modes of representation. Such questioning and

---

<sup>26</sup> This is echoed in my project *Enchiridion*, which uses old printers to create a series of user manuals that disrupt the logic of online instruction sets.

manipulation of time is suggestive of how the post-digital challenges ideas around chronology and historical narratives.



Figure 26: *Just in Time, or a Short History of Production* (Antin, 2010a). Image: © Xavier Antin. Permission granted by Xavier Antin.

Fig. 26 illustrates a third project by Antin, *Just in Time, or a Short History of Production* (2010a). This project consists of four generations of printers (1880–1976), and each machine produces one colour in a book. The machines print out of line, with offset utterances acting as a printing history of sorts. It raises concerns around network and communication. Antin’s work unifies the disparate machines, travelling through time and accentuating the post-digital

tendency of an uninterest in chronology. A physical paper lineage is created between the printers, analogous to my project *[mis]Feeds*. In both Antin's and my project, desktop printers are repurposed as artistic apparatus; they are performers that circulate information.<sup>27</sup> Antin's practice merges distinctions between new and old technology, now and then, to identify novel forms of usability and reflections on the role of the internet and digital culture.

Artin's work on *Just in Time* resonates with Hans Haacke's seminal project *News* (1969/2008), another example that considers the circulation of online information analysed in terms of agency. In addition, *News* challenges time-space-place through a printer located in a gallery and producing RSS news feeds from all over the world. Shown forty-nine years after its inception, today this stuttering, pausing printer might seem frustrating or irritating in comparison to the immediacy of social media such as Twitter. This is something I highlight with *[mis]Feeds*, as the loops of paper build slowly and do not mimic online equivalents. Haacke hoped his project, acting as a form of protest, would break down barriers between art and politics. He questions how news is a hard thing to live with, always alerting and interrupting, and is

---

<sup>27</sup> Analogous to my project *[mis]Feeds*, which repurposes desktop printers as performers that circulate looping information on a paper feed that connects them physically.

perhaps a moral necessity – especially in the light of recent events with Covid-19. Like Twitter, albeit an analogue version of sorts, *News* compresses information. My project *[mis]Feeds* is similarly reductive, with the accumulation of information presented in a flattened form that accrues and bunches up. The mass of information prompts a numbness and disinterest, in juxtaposition to our unhealthy addiction with real time information and being up to date, reflecting the post-digital attentiveness to liveness. Both *News* and *[mis]Feeds* confront the quantity and speed at which we can digest information, and address ideas of information overload and liveness. Moreover, by transporting anecdotal journalism into the gallery, Haacke's project stresses the dehumanisation and immateriality of digital culture, with the printer feed lending an immutable materiality. Whilst materialising the immaterial dimension of information is not new territory in artistic practice, Haacke's work resonates with current debates on misinformation and fake news and advances my argument on the agency of error.

Taking the turbulent relationship we have with digital information a step further, in *Each and Every Command* (2016), the third artist Martin John Callanan documents twelve years of every command, edit, or mistake he made in Photoshop in an unredacted form, later printed as a book (Fig. 27) – his work



Figure 27: *Each and Every Command* (Callanan, 2016). Image: © Martin John Callanan. Permission granted by Martin John Callanan.

informs my project *Enchiridion*. Callanan draws on ideas of the post-digital and addresses agency and the artist's place within digital systems. He adopts a systematic approach to collating his mistakes, placing the artist's intention within a network of human and machine relations. The list-like collation of data presents an abstracted narrative and archive of errors. Bringing together Callanan's data collation, Haacke's concerns for redaction, and my own project *[mis]Feeds*, all of which explore breakdowns in circulation of information, an interesting relation surfaces between these repetitive and systematic practices and printmaking itself, which is often reductive. By collating data that is

automatically saved to Google Drive, Callanan further investigates how autosave functions are comforting and prevent data loss through computational failure, or human error. The project alludes to the way our lives are affected by automatic save functions, the to-do lists we make, and the activity trackers we wear. From the moment we wake up, our data is constantly being saved and updated. Our dependency contributes to the post-digital sensibility, prompting the need to rethink our relationship to technology and the way it infiltrates the everyday. Conversely, this turbulent relationship could be seen to promote our use of and the assurance we find in analogue, unconnected, and physical machines, such as a typewriter. Callanan's work reinforces the complexity of post-digital practices, because they involve digital and analogue processes and the unpredictability of people.

The fourth artist Dane Mitchell's work adds more dimension to the dialogue on agency and post-digital print by exploring the relationship we have with information, through working with an old printer and printed matter which cross-references with my projects *[mis]Feeds* and *Enchiridion* (Fig. 28).

In *Post Hoc* (2019), Mitchell takes issue with the materiality and function of the book and challenges modes of distributing information. He confronts assumptions that accumulating and sharing information enables us to better

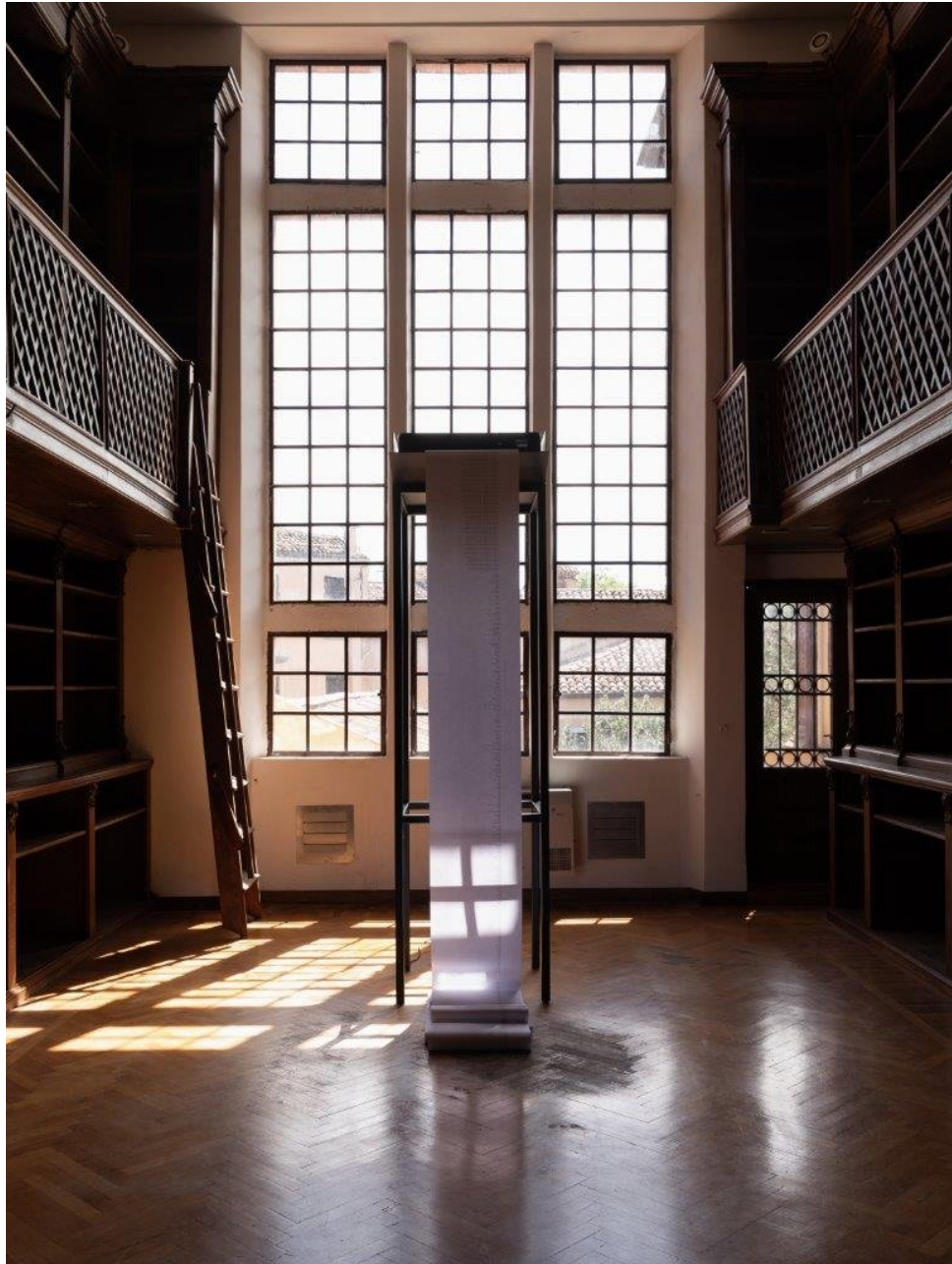

Figure 28: *Post Hoc* (Mitchell, 2019a). Aotearoa New Zealand National Pavilion at Venice Biennale, 2019. Image: © Dane Mitchell. Photographer: David Straight. Permission granted by Dane Mitchell.

understand the world. Similar to my project *[mis]Feeds*, Mitchell's work confronts the idea that we are over-connected, alluding to a sense of

information excess. The curator of *Post Hoc*, Zara Stanhope, explains that our heightened awareness of the world, in turn, can cause anxiety as 'humankind has become increasingly self-conscious of its social and individual conditions' (Stanhope, 2019a, p. 1). Mitchell proposes that potentially dubious information can create an alternative to uneasy social, political, and cultural realities; a welcome distraction, perhaps? Stanhope discusses Mitchell's perspective, suggesting we can 'disempower the worry through avoidance, false news and disbelief' (2019a, p. 2). The question Mitchell poses, through a broad interpretation of the physical book form, is whether affirmation of false information can promote reinvigoration and truth?

Mitchell's project materialises an archive of histories that are no longer visible, thereby examining the agency of materialist thoughts and complex relationships (2019a, p. 6). By interrogating the material properties of information, the characteristics of matter and physical forces become tangible and challenge commonplace understandings of digitality. In Mitchell's work, print technologies, alongside computation, distort the boundary between classifications of reality and imaginary spaces, the material and the immaterial (2019a, p. 4). Significantly, in line with post-digital thinking, *Post Hoc* confronts ideas of what is material, and how the book can disperse agency between



artist, printer, and paper. This reflection enables a discussion of how the book is capable of displaying agency.

The book appears in different forms in the projects discussed above, and is adaptable to change and reinvention. That is to say, under post-digital conditions, the printed book is entangled with the digital and new ways of producing and disseminating information. As a post-digital object, it persists alongside the e-book and the internet as sources of information. The artists' book, in all its guises, is prominent and extensive as we saw in Antin, Haacke, Callanan, and Mitchell's projects. Nevertheless, in addition to these practices, which closely parallel my own, it is useful to mention other contributions capable of unfolding how artists are reconsidering and reimagining the book as a textual machine.

Through the medium of the book, the artist Guy Bigland interprets the relationship between language and articulation, and the role language plays in recording, describing, and interpreting. Bigland's manipulation of language occurs in list-like forms that are highly systematic and, although methodically created by the artist, resemble something created by a computer. He manually lists all possible configurations of two-character, or three-character, combinations in the alphabet (Fig. 29 and Fig. 30 respectively), in a move symptomatic of how humans are taking on the attributes of computers. This

approach can be cross referenced with the analogue algorithm used to manually reproduce instructions in my project *Enchiridion*. Additionally, Bigland's practice has been influential to me, as despite his algorithmic thinking, it flows between rationality and irrationality, highlighting the creativity of using language as a material object and contributing to my discussion of agency.



Figure 29: AA to ZZ (Bigland, 2019). Image: © Guy Bigland. Permission granted by Guy Bigland.

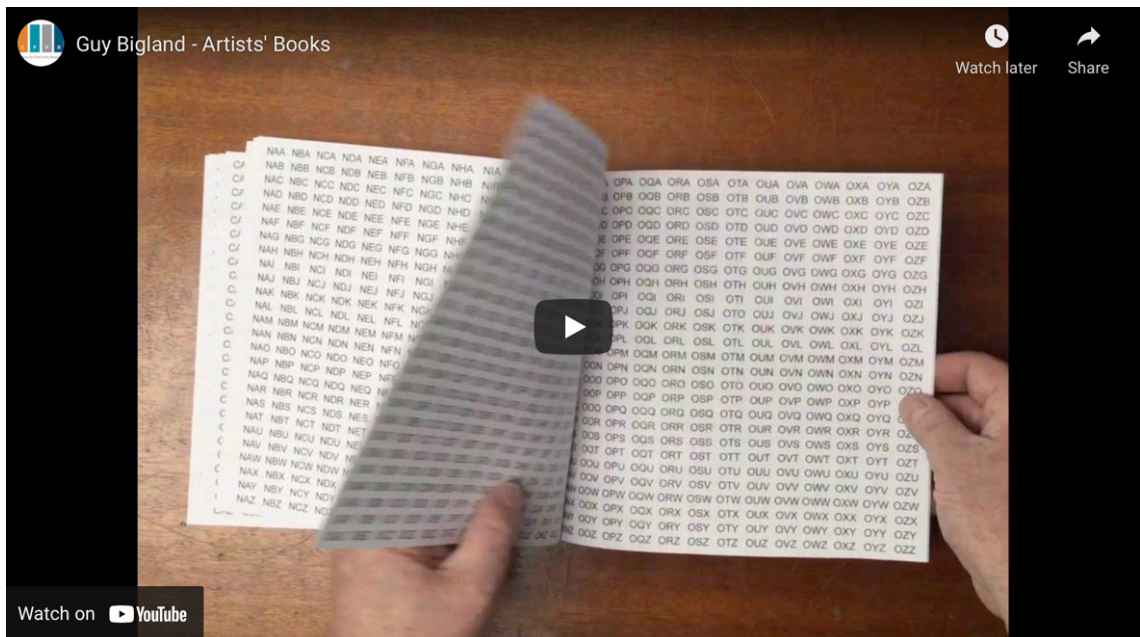

Figure 30: AAA to ZZZ (Bigland, 2018). Image: © Guy Bigland.

Taking book and textual practices a step further, the illogical texts contained in the artist Benedict Phillip's publication *A Benedictionary* (2011) are systematic translations of standard English spellings into phonetic-esque 'Dislecksick' misspellings (Fig. 31), highlighting the tension dyslexia sufferers' feel when confronting written language. The relationship between correctly and incorrectly spelt words is valuable in the way the texts' intention can still be understood despite the incorrect spellings.<sup>28</sup>

---

<sup>28</sup> This is an elaboration on how in *Enchiridion: Levenshtein* the distance between correct and incorrect spellings is manually measured, creating a numerical calculation of the distance between arbitrary error and non-error (see User Guide).

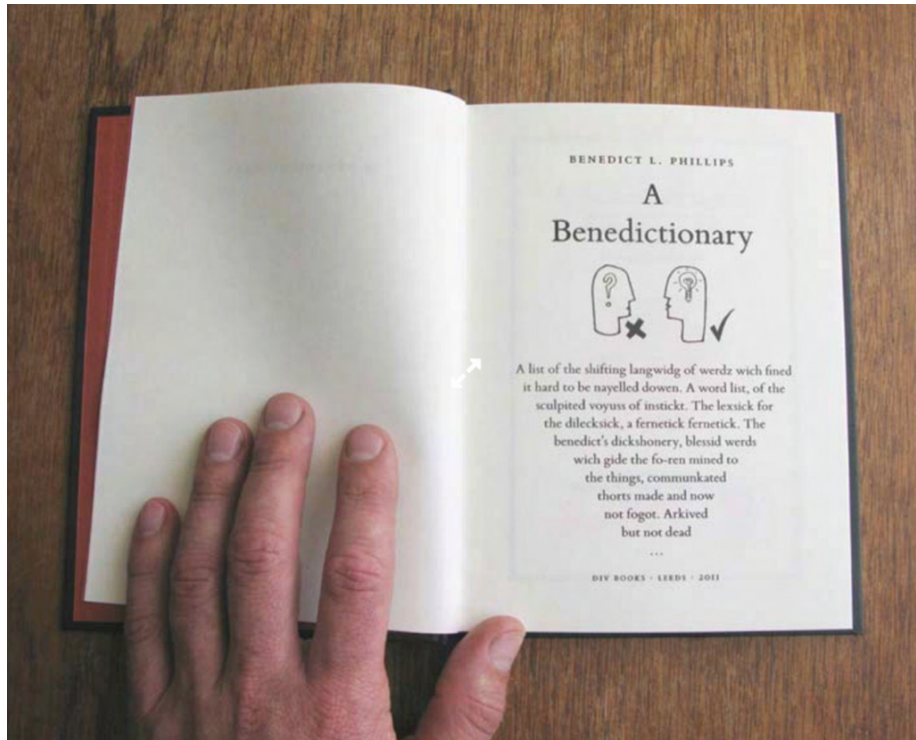

Figure 31: *A Benedictionary* (Phillips, 2011). Image: © Benedict Phillips. Permission granted by Benedict Phillips.



Figure 32: *No. 82*, a publication by Pist Protta celebrating errors in print. Image: © Space Poetry publishing. Permission granted by Space Poetry publishing.

All of this exemplify how artists are rethinking the cultural role of the book, which under post-digital conditions is subject to perpetual change. Lastly, I would like to briefly reference artists' book publisher Pist Protta (Fabricius et al., 2018) and their exploration of mistakes and slip-ups in publishing as 'artistic grip' rather than a threat (Fabricius et al., 2018). Publication No. 82 is notable for seizing the potentiality of printed errors – for instance, offsetting, poor registration, moiré, upside down images, missing pages, and folded pages as in Fig. 32 – and thereby contributing to how errors in print are comprehended differently as a consequence of post-digital practices and thinking. My research takes these examples as an indication of some of the key influences to establish a currency for the approach.

### **3.3 The diagram as a post-digital device**

The artistic practice of diagramming is pivotal in this research when mapping the relations between interpretations of error, as well as the core concepts of agency and the post-digital which are introduced in Chapter 1. The Meta-Diagramming project (in the Appendices), moreover, sets out a detailed theoretical framework of the conceptual diagram and, in doing so, leaves

space here for me to review diagramming as a practice that supports my preference for hand-drawn rendering.<sup>29</sup>

The hand-drawn diagram creates a direct relationship between thought and surface, without intermediary. It maps ideas which are often ahead of conceptual thought (O'Sullivan, 2016, p. 21), and pinpoints the areas where errors transpire in thought or physicality, uncorrected by technology. Relationships in a hand-drawn diagram are often convoluted because of the unpredictability of our thoughts.

When creating her diagrams, the writer and curator Mara Ambrožič talks of the synchronised relationship between handwriting and the language of thought (Fig. 33). Her approach reinforces my proposition that the hand-drawn diagram is a post-digital response to visualising ideas and information, through which artists cannot only navigate relations through fast-paced technologies and complex systems, but instead choose to reimagine relationships and engage in creative and speculative thinking.

---

<sup>29</sup> The Meta-Diagramming project has been developed from a paper delivered at the Society for Artistic Research conference SAR10\*, 2019.

Suzanne Treister is another artist who has also seemingly rejected the use of digital media in her watercolour diagrams which explore techno-human futures, echoing a post-digital aesthetic in her imaginary diagrammatic taxonomies (Fig. 34). Treister's post-futuristic focus on our relationship with technology provides a complex political reflection on the role of the internet and digital culture, which influences my thinking of the diagram as a site of cultural commentary or resistance. The theorist David Berry's hand-drawn diagrams on the philosophy of software likewise provide insight into the post-digital and the agency of technologies (2017) (Fig. 35).<sup>30</sup> Furthermore, his diagrams explore issues on how we are in a period where we need a physical re-materialisation of digital technology in order to change the way digital memory is approached.

The below examples of post-digital diagrams explore relationality through 2D practices. There have been artists, however, whose works have been important to my research project as they explore relations through performative and social diagrammatic methods.<sup>31</sup> The artist Dean Kenning posits the diagram in reaction to social forces, approaching diagramming as a performative and

---

<sup>30</sup> Berry created the diagram, *As We May Think* in 2010, as his contribution to a publication in place of a written chapter (Lewandowska and Ptak, 2013, pp. 14-15).

<sup>31</sup> At the SAR10\* conference in 2019, I delivered a performance presentation of (mis)folded diagrams, and a subsequent participatory diagrammatic workshop questioning how error persists, disrupts, and creates disorder. During the workshop the participants and I created a space that disrupted digital orderliness through a methodological process of creative disorder.

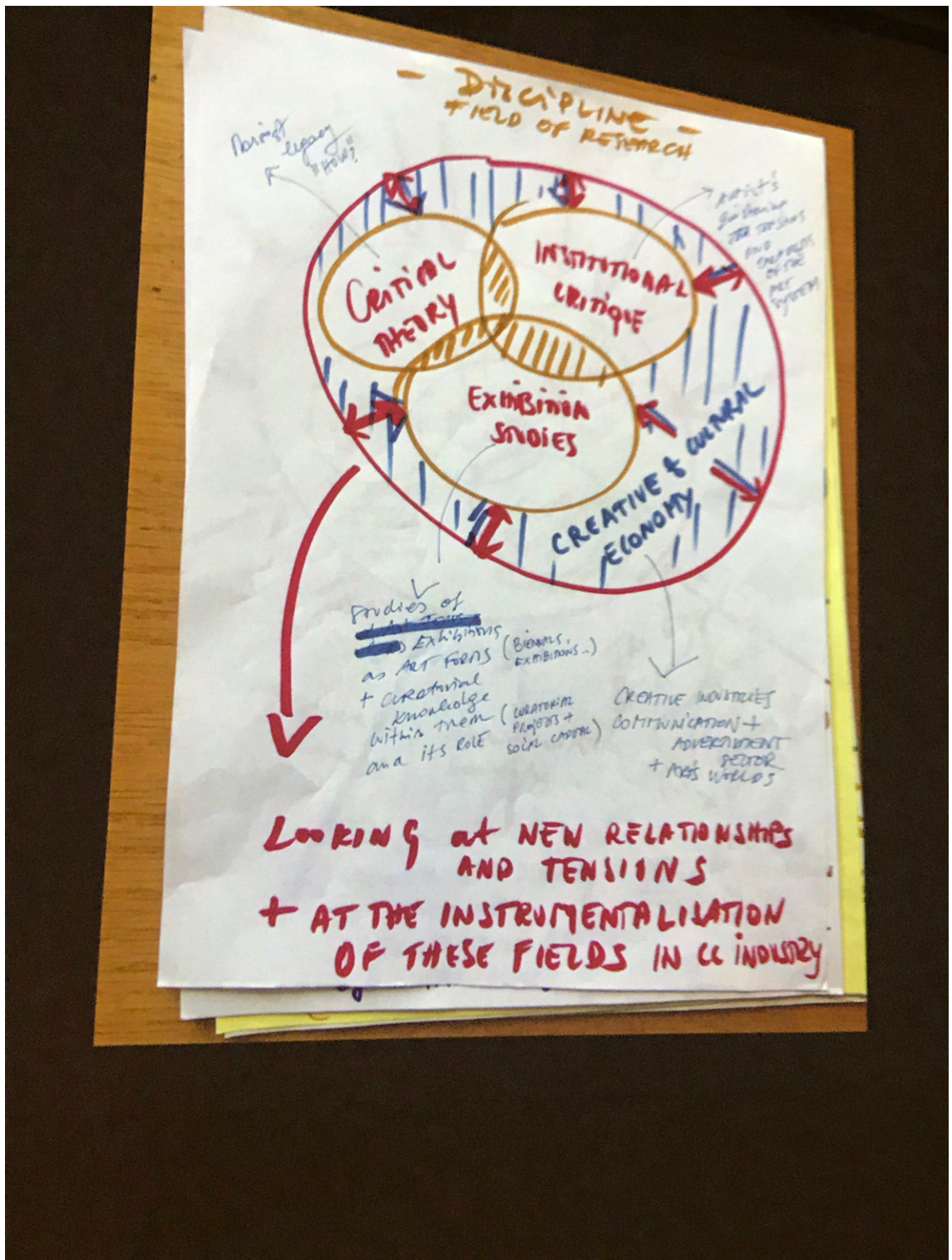

Figure 33: Diagramming Art's Institutional Global Playgrounds (Ambrožič, 2019) at a research workshop, University of Plymouth.





Figure 34: *SURVIVOR (F)/Mystical Apocalypse* (Treister, 2016–2019). Image: © Suzanne Treister. Permission granted by Suzanne Treister.

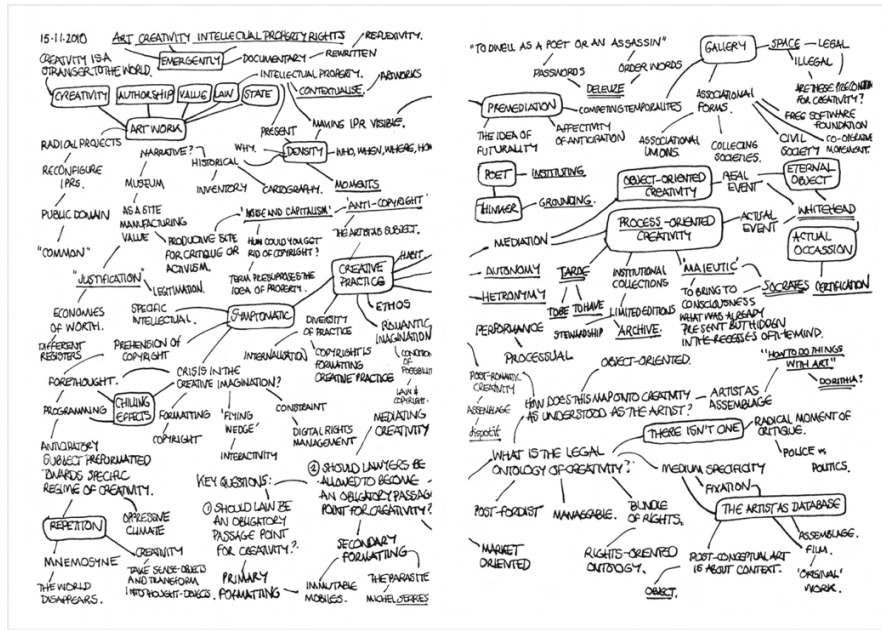

Figure 35: Hand-drawn diagram *As We May Think* (Berry, 2010). Image: © David Berry. Permission granted by David Berry.

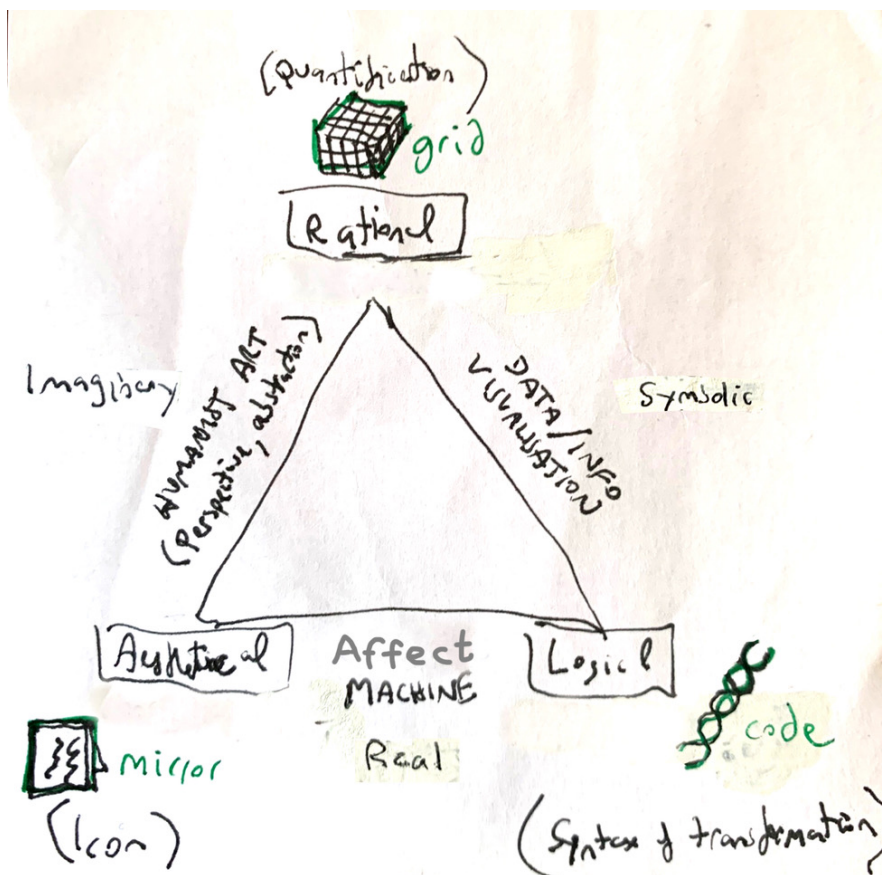

Figure 36: *Aesthetical-Rational-Logical Diagram* (Kenning, 2020), produced during a live drawing project. Image: © Dean Kenning. Permission granted by Dean Kenning.

collaborative act (2011). Kenning's performative cognitive maps locate thinking as a place-space and as a live drawing practice without thought for the consistency or the legibility of a written text (Fig. 36). My diagrams follow this rationale as well; like a drawing, my diagrams operate at different speeds, and this affects relations. Alessandro Carboni's practice also approaches the diagram as a performative object, contributing a nonverbal and temporal aspect to the diagrammatic discussion (2016) that supports my performative approach in *[mis]Folding*. Another example is a collaborative project led by *Banner Repeater* member Ami Clarke (2012), exploring the unacknowledged currency of data and our agency, or lack thereof, in online spaces (Fig. 37). Through repurposing devices, the work becomes a site of collective writing experiments.



Figure 37: *de-leb* (Clarke, 2012), a collaborative project led by Ami Clarke of *Banner Repeater*. Image: © Ami Clarke. Permission granted by Ami Clarke.

As we have seen, diagramming as artistic practice is widespread. The examples discussed here are partial, chosen because of their influence on the post-digital field. Whilst mentioned briefly, the works of these artists indicate how the diagram is a sophisticated artistic method, capable of producing dynamic systems and inter-relationships. This approach is in tune with my own diagrams, representing an artistic endeavour to reimagine our complex relationship with error, post-digital print, and technology.

### **3.4 The art of instruction**

Ideas around instructions in artistic practice materialise throughout my projects in various modes and intensities, providing access to error and – despite their associations with order – disrupting the orderliness of computational logic and binary understandings of error. This final section of the survey calls on this conceptual field of practice, where instructions are an artistic action. I draw on how artists are using instructions as both a medium, and a method, of engaging with an audience.

There is a long and rich history of instructions as art practice. They come in many forms, from instruction paintings of John Baldessari, and concepts of scores by Yoko Ono and others, to the chance operations of Tristan Tzara,

Marcel Duchamp, John Cage, and other Neodadaist and Fluxus artists. More recently, printmakers such as Cathey Webb and Sarah Bodman, and performance works by Emma Cocker make use of this tactic. Whilst my intention is not to map out the instructional field in detail, the following examples are relevant to my projects because instructions are a provocation for error, disorderliness, post-digital print, and live-art.

The Dada movement, which began in 1916, is notable for translating art into *action*. It is distinctive for the way artists produced non-rational and nonsensical errant readings, performances, and poetry – rejecting the literal and rational values of bourgeois society following World War I. Dada's approach of refusing logical thought contradicts the understanding of achievement or object-oriented tendencies as success. It rejects traditional artistic values and clear definitions of art objects, including prints, and embraces action. For example, Tristan Tzara wrote a set of instructions *How to Make a Dadaist Poem* (1920), which encouraged the audience to embrace chance and uncertainty (see Fig. 38). Whilst Tzara created instructions that on first appearance seem lucid and easy to follow, the content promotes nonsense. The mischief evokes the misadventure in my project *Enchiridion* (see User Guide). Tzara's instructions remain open, providing a provocation for error and general confusion and signalling a move away from conventions of logic and order.

TO MAKE A DADAIST POEM

Take a newspaper.

Take some scissors.

Choose from this paper an article of the length you want to make your poem.

Cut out the article.

Next carefully cut out each of the words that makes up this article and put them all in a bag.

Shake gently.

Next take out each cutting one after the other.

Copy conscientiously in the order in which they left the bag.

The poem will resemble you.

And there you are—an infinitely original author of charming sensibility, even though unappreciated by the vulgar herd.

Figure 38: Written instructions on *How to Make a Dadaist Poem* (Tzara, 1920).

In 1960 the Fluxus group continued this instructional narrative, overthrowing the value of craft in favour of a radical turn to anti-commercial and anti-art sensibilities – which rejected earlier art definitions – and where art was part of life and for everyone.<sup>32</sup> Sharing attitudes with Dada, the Fluxus community is renowned for focusing on events and actions over objects and products, promoting a wide range of art forms. Notably, Fluxus artists advocate living art and anti-art through the use of scores and instructions as events – which my project *Reading Enchiridion* also attends to (see User Guide). Yoko Ono's event

---

<sup>32</sup> Fluxus was founded in 1960 by George Maciunas. The collective of artists, poets, designers, and composers – largely active during the 1960s and 1970s – continues today. The Fluxus network included conceptual artists such as John Cage, Nam June Paik, Joseph Beuys, John Baldessari and Yoko Ono.

scores, *Grapefruit* (1964) for example, initiated live readings and performances.<sup>33</sup> Importantly, Fluxus' works took on a new energy, fostering an avant-garde set of ideas about what art might be. This calls to mind the ambitions of the post-digital – which whilst concentrating on technology – also signals a move away from valuing physical art objects.

For digitality this approach also resists the idea that value lies in the work itself, and promotes the value of the collaborative, temporal, or digital aspects.

Although code-based works and online instructional works connect artists with computational and systematic thinking, they also present opportunities for the unfinished and imperfect.

*Do It* (Obrist, 1993 in progress) is an example of online instruction sets which feel infinite and diverse. The ever-expanding compendium of online instructions is composed from entries created by a collection of leading artists.<sup>34</sup> The vast digitised manual of co-created instructional works functions

---

<sup>34</sup> The project was initially conceived in 1993 by curator Hans Ulrich Obrist and artists Christian Boltanski and Bertrand Lavier. Instructional entries include Yoko Ono (discussed above), philosophers, critics, novelists, choreographers and so on.

as a series of provocations for action. The *Do It* model is especially interesting for post-digital contexts as it presents an open model of collaboration – much like wikiHow (see User Guide). They favour global community models over mass media and are sympathetic with post-digital values echoed in open-source code-based works (see Cramer, Chapter 1). As Obrist describes it, *Do It* has the ‘quality of unfinishedness and incompleteness’ (Max, 2014); and the compendium imparts an ongoingness or unfinished quality to an audience or offers the capacity to the user to contribute.

Given this discussion, focusing on the temporal and event-like nature of instructional practices, Peter Liversidge’s installation *Jupiter Proposals* (2008–2009) investigates instructions as tangible printed forms. The project is durational, consisting of one hundred and thirty-four typewritten proposals which the artist submitted to the Jupiter Artland gallery between 2008 and 2009 (see Fig. 39 and 40).<sup>35</sup> Liversidge’s typed proposals are an invitation and guide for others. This project is productive owing to its printed material existence, which being typewritten (and complete with typos) can therefore be

---

<sup>35</sup> Jupiter Artland is a contemporary sculpture park and art gallery outside Edinburgh.



PROPOSAL FOR ROBERT AND NICKY WILSON FOR THE SCULPTURE PARK  
AT JUPITER ARTLAND, BONNINGTON HOUSE, BONNINGTON,  
EDINBURGH, EH27 8BB.  
December 1st 2008 - 31st January 2009.

I propose to bring a stick I found on the streets of London  
and search Jupiter Artland for it's twin.

Peter Liversidge.

Figure 39: *Jupiter Proposals* (Liversidge, 2008–2009). A typewritten proposal submitted to the Jupiter Artland gallery. Courtesy Jupiter Artland and the artist. Photograph © Keith Hunter.



Figure 40: *Jupiter Proposals* (Liversidge, 2008–2009). Installation view. Courtesy Jupiter Artland and the artist. Photograph © Keith Hunter.

appreciated for its errors and uncontrollable aspects, and for the way it is an opening for collaborative practices.

In the subsequent parts of the thesis, I will return to instructions and how each of the projects speaks to them in its own way.

## Summary of Part One

The objective of this opening discussion was to prepare the reader for the main discussion and body of practice commencing in Part Two of the thesis. So far, I have set out fundamental information on error, agency, and post-digital print practices and thinking, providing an essential foundation for the following examination of error and its potential as a creative and unforeseen slip.

As I hope is clear by now, error, post-digital print, and agency are core terms which will remain prevalent throughout the thesis. The diagram of my research mechanisms has sought to map out the relations between these key concepts and my research approach and rationale. The subsequent review of the field served to establish the potential audience of my research and located my research in the field of post-digital print or the wider field of expanded printmaking.

As we have seen, historically the relationship between analogue and digital is complex and problematic. The post-digital undermines any form of distinction, or a rift, and this was examined in Part One through confronting the assumption that *digital* means *better*, or that technological development equates to *progress*. The post-digital calls into question historical periodisation

as a method of understanding digital culture, and I have used this concept to clarify how the discussion outlined here is about far more than nostalgia. My thesis thus far has drawn upon post-digital attitudes in relation to printmaking and a favouring of the technological flaws and errors that are inherent in print media, new and old. In terms of post-digital print, my analysis puts forward how errors in print operate differently as a consequence of our understanding and use of digital systems. Furthermore, I have established the complexities of common understandings of error, and how the focus on error sets forth discussions on error and its materiality. This discussion on the underlying principles of the PhD project permits space to focus on the more in-depth exploration that follows.

## PART TWO

This part of my thesis investigates error's capability to promote unknowing and the artistic potential this activates in my post-digital print-based practice and thinking. Knowing is problematic because digital information is so ubiquitous and accessible that it removes a sense of wonder, awe and discovery, which creates a reductive understanding of the world. Part Two is concerned with how the post-digital is a messy process – rather than an informational or didactic programmatic one – which provides a set of ideas and practices to challenge certainty and knowing. This discussion builds on the framework established in Part One where, under post-digital conditions, error in print surfaces as a complicated phenomenon due to our relationship with technology. A pivotal objective of the discourse across Part Two is to show how errors break down and disrupt digital logic and knowing in artistic practice. This argument is substantial and considered across two chapters and associated projects: Chapter 4 and *Enchiridion* on how post-digital error is messy because it involves digital and analogue processes; and Chapter 5 and the project *Reading Enchiridion* on how this messiness goes deeper because of the unpredictability of people and our relationship with error.

Specifically, Chapter 4 considers how errors in print can be understood differently as a consequence of post-digital practice, systems or cultures. The focus of this chapter is on how print technologies and computation can break down not only classifications, but logic itself. This narrative intensifies in Chapter 5, advancing my argument that error exposes us to the unknown and transgresses outside or beyond explanation or clarification. My aim is to defend error as an entity beyond categorisation, beyond existence in the sphere of *yes or no*, but which is rather a projection of *yes and no*.

## Chapter 4: Error in Post-Digital Print

This chapter looks at how post-digital thinking and practices not only embrace misbehaving technologies and errors as creative opportunities, but, in terms of my research, how these call for a rethink of printmaking. I conceptualise errors in print in relation to my project *Enchiridion* and the post-digital conditions introduced in Chapter 1 as creative agents of disruption in art practice. In the first section, the discussion builds on Part One by suggesting the post-digital marks the end of a search for perfect technology. The section to follow highlights how digitisation has irreversibly impacted print, and goes on to argue that, despite periods of uncertainty and change, print persists. Lastly, a resistance to binary, digital logic is highlighted through outlining the messiness of print and its openness to error and lack of artistic control.

### 4.1 Post-digitality

I have established broadly how print is understood differently as a consequence of post-digital conditions (see Chapter 1). Yet before going into the specifics of post-digital print and *Enchiridion*, it is necessary to reflect more deeply on the impact of the digital on printmaking and how digitality can be seen to disrupt the spirit of print.

Digitisation has irreversibly impacted print. It calls its physicality into question, from the distinctive aroma of ink and chemicals in print workshops that do not translate or exist in Negroponte's 'digital neighbourhoods' (1995, p. 7) introduced in 1.2, to the manual action of turning a low-g geared press wheel now juxtaposed against the immediacy and un-bodily experience of clicking the *print* icon. Let us consider print communities that exist worldwide, and the ritual of the *big reveal* where a group of curious printmakers huddle around the press bed to observe the blankets being folded back and share in the moment when the process has been successful, or not. The ritual is nowadays filmed on smart phones and shared instantly on Instagram groups such as *Printmakers of the World*. If it is not captured digitally and shared, it is as though this moment did not exist. This leads to an enmeshing of the post-digital conditions – discussed in this chapter and explored in *Enchiridion* – which reflects my claim that the digital not only impacts print, but it also disrupts it in unforeseen ways. It alters the way we think and perceive things that are not *digital* in the traditional sense or have been digitised. Building on the discussion in Chapter 1, which established how the digital is embedded in society, it is important to envisage what we have learnt from the digital in terms of print. The crucial point here is that digitality throws into disorder the very essence of printmaking by confronting ideas around physicality, repetition, multiplicity and the limited edition, community, dissemination, the demands of time and the value of slow



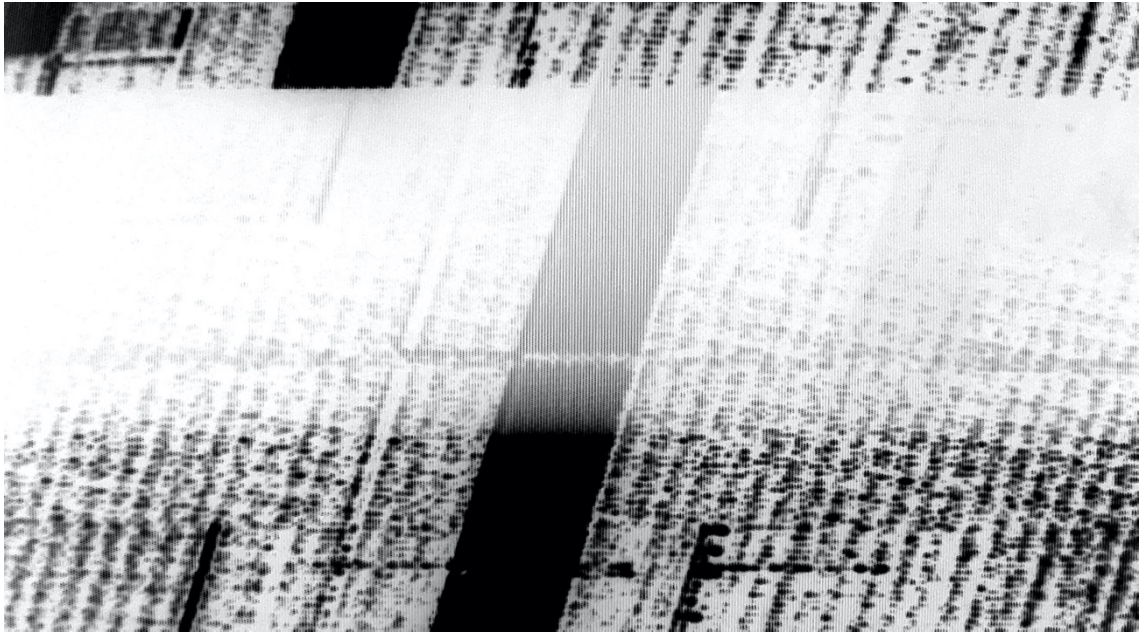

Figure 41: Laser cut woodcut print (Rosser, 2018). Image based on distortion of a CRT monitor.

processes, and the creative unforeseen. Disrupting these fundamental characteristics of traditional print is suggestive of how digitisation complicates our understanding of printed matter. One outcome is that errors become both disrupted, and disruptive. For instance, digital aquatint screens that are created with a perfect scalable *randomised* dot – and are complete with *errors* – are used in place of manually created, actually *random* dot screens that are uneven, blotchy, and irregular. This change recalls questions such as: What is an error under post-digital conditions? And which errors are acceptable, and under what conditions? Advancing on my argument in Chapter 1, I posit that post-digital print presents a shift in the decision-making process concerning the errors I accept and those I don't (Fig. 41). Rather than choosing errors

based on literal understandings, in *Enchiridion* decisions are made depending on a system's ability to generate unknown elements and unforeseen potential in the form of errors – tradition is not prioritised.

There are obvious shifts in terms of process, with digital technologies such as laser cut wood blocks now commonplace in print workshops, exhibitions, print fairs, and journals challenging the validity of traditional hand cut woodcuts that are, in terms of my print practice, at times joyously laborious, slow, and prone to error (Fig. 42 and Fig. 43).<sup>36</sup> In post-digital print practices, these latter attributes enmesh with digital processes, freely intermixing with analogue methods to produce, for example, a multi-block print with different components cut by hand or machine. New digital technologies have transformed the status and role of printed material. In *Enchiridion*, the relationship between analogue and digital print is reciprocal and, although profoundly different, on an equal footing. The digital is valuable for being editable, searchable, shareable, and possibly connected, and the analogue is apposite for its physicality and immediacy. Therefore, it can be said that the disruption traverses both ways, with print casting doubt on our digital being

---

<sup>36</sup> Often printmaking has a lot of labour involved, yet the high level of care is offset through the creation of multiples.

and vice versa. Apps that *print on demand* and apply a quasi-woodcut print grain to holiday snaps, for instance, question the value of digitised filters in print – reminiscent of the discussion in 1.2. I have observed how in artistic practice it is no longer assumed that digital is the best solution and, returning to Prensky’s idea of *digital natives*, this disruption has seen a rise in artists returning to the imaginative uncertainties of printmaking.



Figure 42: *We Ain't all Middle Class Bohemians* (Rosser, 2015), hand cut woodcut.



Figure 43: Detail of woodcut experiment (Rosser, 2018).

### *Post-digital error and the unforeseen*

To adopt the term *post-digital* (Cascone, 2000) is to demonstrate lack of interest in debates surrounding analogue versus digital, periodisation, or

technological progress.<sup>37</sup> As previously acknowledged in Chapter 1, the post-digital posits a resistance to such logic. I also established how methods or thinking once belonging to the realm of digital practices have now been embraced across a number of interrelated creative fields – in the case of this thesis: printmaking.

In the present section, I focus on our interrelation with technology, which cuts across different platforms and categories such as human and nonhuman, and has become central to ideas of breaking or crashing technologies and systems, and of addressing degrees of failure. Error (and glitch) signifies the end of the search for perfect technology and this is an area where my contribution to new knowledge is located. I propose that error, as cultural commentary or resistance, can uncover new forms of usability and political reflections when it comes to the role of the internet and digital culture.

A lack of sympathy for technological perfection along with an exploration of how error is symptomatic of alternative modes of usability permeate my project *Enchiridion* (see User Guide). In this project, the entanglement of systems and

---

<sup>37</sup> An illustration of this is the revival of the Nokia 3310 mobile phone model seventeen years after the original launch, which is a(n un-smart) phone that is only capable of making calls and sending texts.

technologies – such as the degenerative qualities of a dot matrix printer ribbon with the infallible scalability of a vector for digital print, or an algorithm twinned with the logic of online instruction sets (Fig. 44 and Fig. 45 respectively) – are put to play to explore how post-digital thinking, culture, and practices make us feel differently about error.

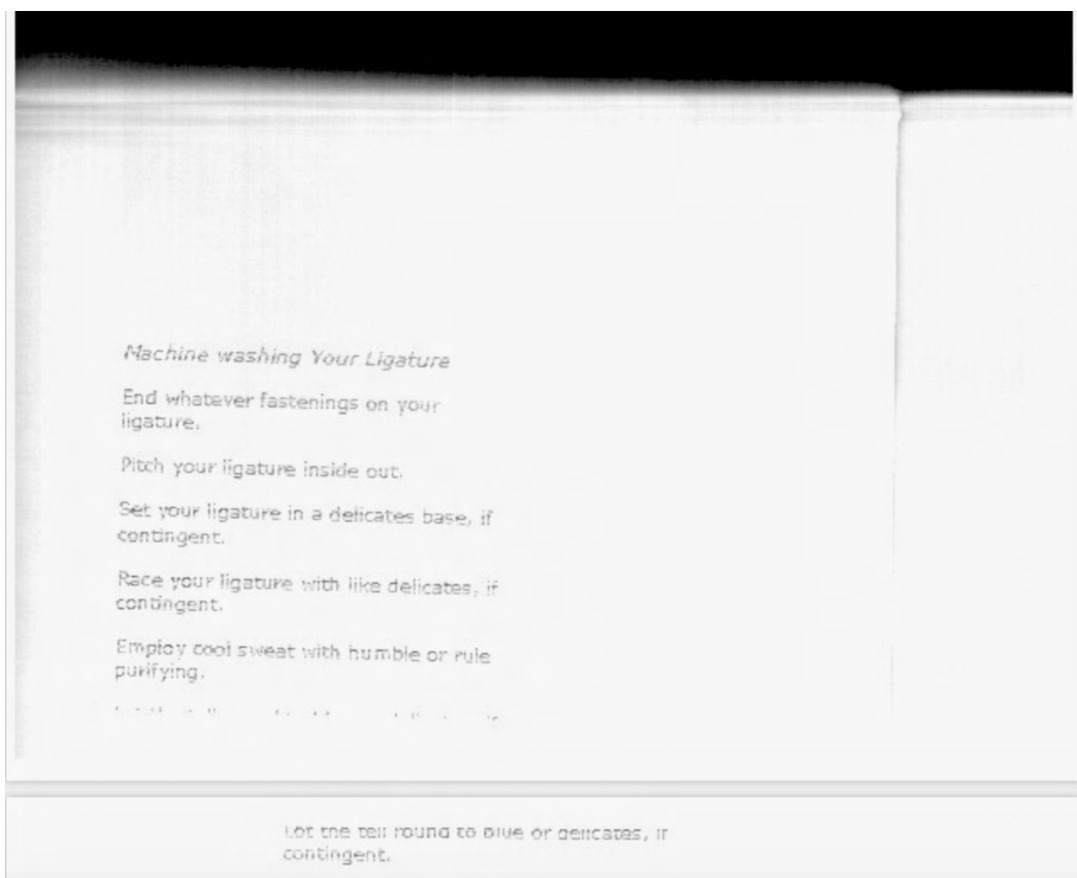

Figure 44: *Enchiridion: Machine Washing Your Ligature* (Rosser, 2019), detail of dot matrix printed instruction guide.

Although the post-digital is commonly associated with the concept of *failure* and its capacity to create glitches, slips or noise (see Chapter 1), the discourse

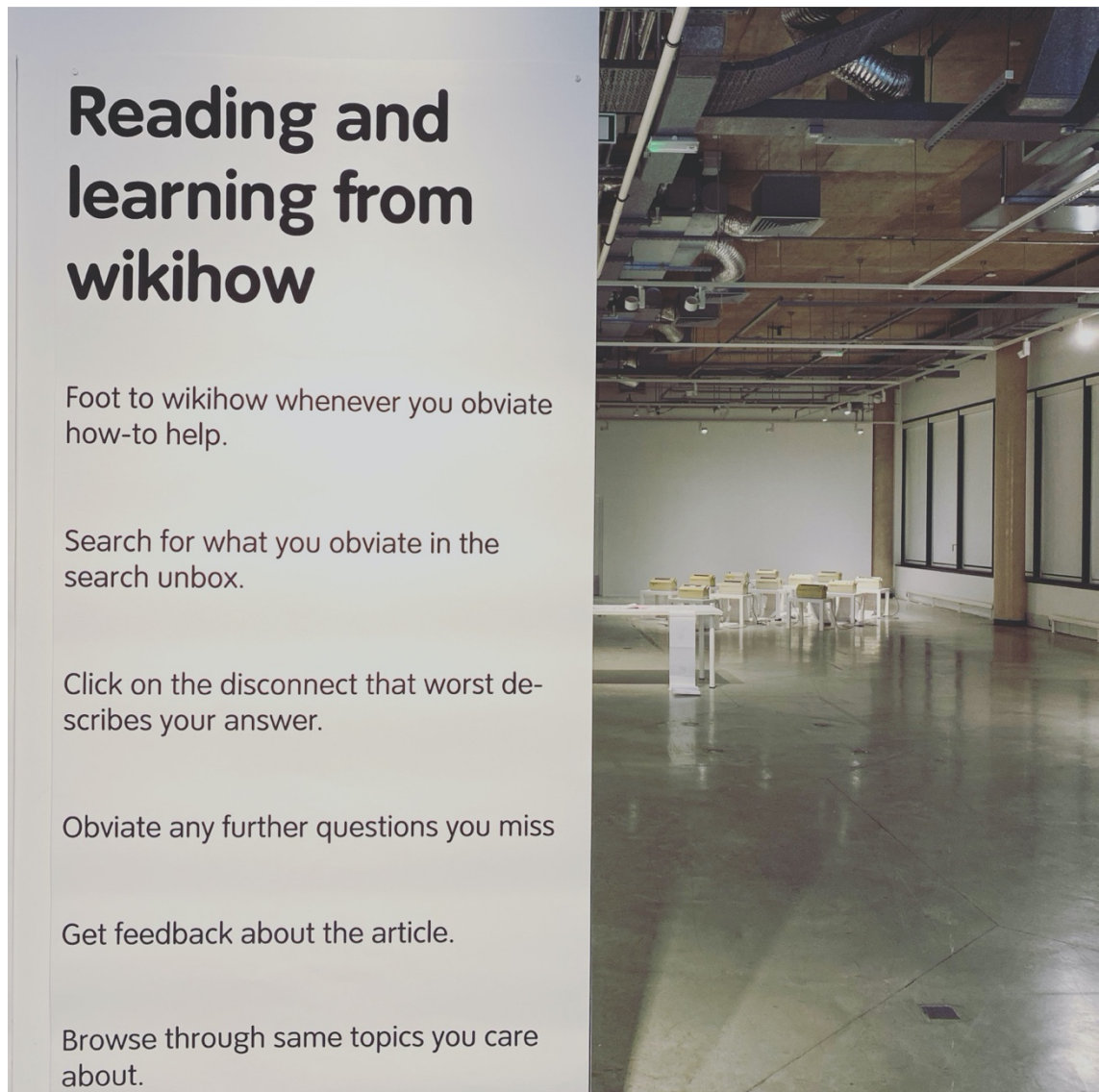

Figure 45: *Enchiridion: Unlearning Space* (Rosser, 2021), large instructional printed panels welcome the audience to the exhibition at Arts Institute, University of Plymouth.

has shifted to include concerns over the unexpected in social and political digital cultures and practices (Cramer, Ludovico, Gansing, and Bishop *et al.*). The media archaeologist Tim Barker's reinforces this observation by arguing that the post-digital condition seeks out the unknown and the unforeseen in mechanical systems, and that as a result errors 'slip into existence' (Barker,

2007). In view of the latter statement, error can be seen as one of the properties that marks the post-digital age. This is clearly reflected in *Enchiridion*, where unforeseen possibilities are exposed in the form of errors. It is this unseen, unknown potentiality of the post-digital space that my research taps into, and I will keep returning to this point throughout the thesis.

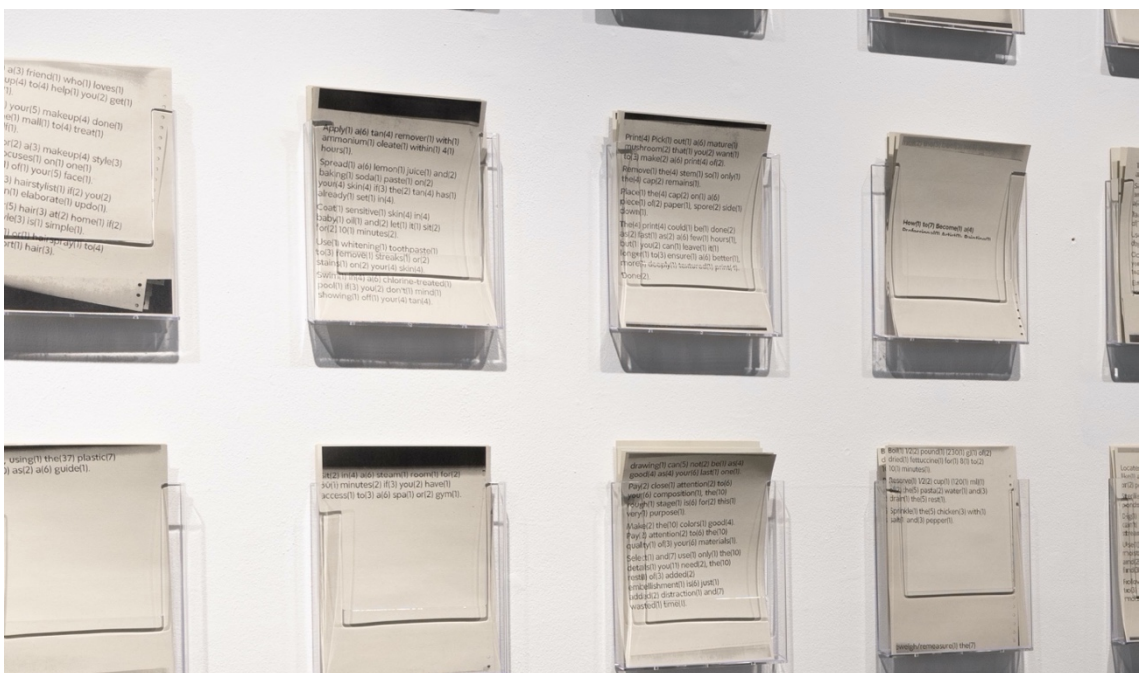

Figure 46: *Enchiridion* (Rosser, 2018), detail from installation of misprinted instruction sets, University of Plymouth.

Barker writes of systems that are open to the unforeseen ‘as surrounded by a cloud of potential error’ (Barker, 2007, p. 5). In the same vein, mechanical systems that create new information in *Enchiridion* are in pursuit of the unexpected. One might argue that a diagram, a 1980s printer, instruction sets,



or pages of a pamphlet all hold potential access to an array of possible errors (Fig. 46). Yet in order for errors to be facilitated into existence, they must first enter the field of potential. In the case of *Enchiridion*, looping and repetitive gestures reproduce instructions that encounter, or collide with, wikiHow instruction sets. This calls to mind Deleuze's theory of the 'virtual' (Deleuze et al., 2002, p. 148), which can be perceived as the *field of potentiality*, and is a key area of my argument which I will return to towards the end of the thesis (see 7.1). *Enchiridion* can likewise be recognised as an area of activity that is linked to potentiality and where error is realised through reproducing as-yet-unthought of instruction sets which I discuss below (Fig. 47 shows multiple stages).

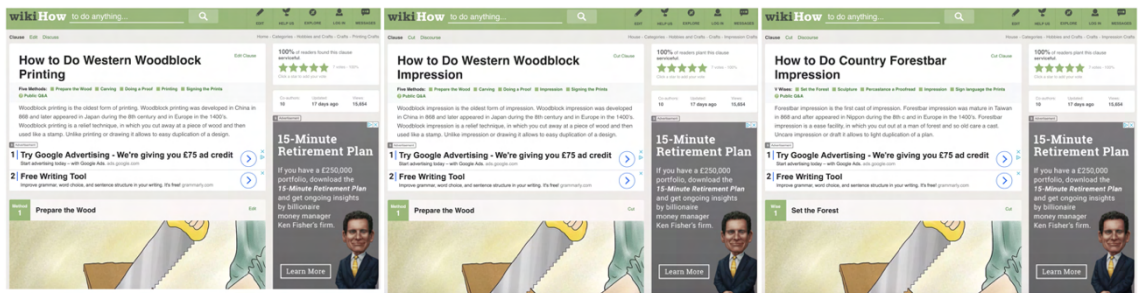

Figure 47: Screenshots taken by me while scraping data from wikiHow articles to collect and manipulate data for errant instruction sets.

In *Enchiridion* my manipulated instructions are materialised using different printed forms, and recreated as multiple workbooks and leaflets (Fig. 46). The

printing processes are themselves instructional. They are carried out using either a photocopier, where pressing the *print* button speedily instigates a chain of machine instructions to produce a print, or printed using letterpress – the most labour-intensive form of print – which entails protracted instructions. Letterpress slows the production process, shifting the focus from foreground and surface to background, and exposing often unseen layers of instructions (see User Guide).

Notably, instructions play an important role in the project in the creation of error. Rather than being a system of information explaining how something should be done, the edited disorderly texts disrupt a sense of direction, or reason. Whilst the content refers to the organisation of banal and everyday tasks, they are multi-scalar as the systems also speak of questionable information in online spaces. The texts instruct error. On one hand, errors exist in the instructions themselves. On the other, the instructions are a creative tool for instigating error in the reader, as they are difficult to follow and impossible to accomplish.

Returning to Barker's claim and its emphasis on error, he not only suggests there are similarities between *error* and *failure*, but also hints at their distinctness. The two terms, although discrete, are intertwined in that both

originate from (technological) faults. To put it simply, they are comparable because an error is the outcome of failing technology, yet they differ because failure occurs when something does not do what is expected. The intention to succeed is irrelevant where error is concerned. As such both terms have an interesting relationship with intention – as seen in Chapter 1, where I discuss their similarities, differences, and complexities of understandings. A key point to me is how my research relates to, and emerges from, failure where it is interconnected to ideas of error in a post-digital framework. This intersection sets forth the following discussion on how the post-digital condition breaks down categorisation and, in doing so, enables error to bridge various interpretations.

Errors emerge out of situations set up by artists as the result of limitations (or failures) of technology, human skill, and knowledge. Our understanding of error is nuanced by post-digital thinking beyond its binary informational form – right or wrong – and it is the associated tensions with (non)fulfilment and expectation that become important in establishing the efficacy of the error.

There is a co-existence between Barker's *error*, which is the emergence of an unknown digression from accuracy or correctness, and Cascone's *failure*, where a technology is considered inadequate and fails to be successful but still produces aesthetic value. This slipperiness between terms is recognised in my

project *Enchiridion* and is valuable in exploring how technological limitations generate error that is a creative and critical tool.

### *Breaking down classifications*



Figure 48: *Auto-Incorrect* (Rosser, 2017). A socially engaged project connecting typists, typewriter, laptop, and dot matrix printer.

Under post-digital conditions, the digital and the analogue are intertwined (Fig. 48). For example, if we take into consideration Cramer's argument that a piano is a digital entity, or that a typewriter is a 'digital writing system' (2014, p.

17), commonplace understandings of digitality are challenged.<sup>38</sup> *Enchiridion* raises similar questions when considering the typewriter more closely: the individual keys and letters are discrete units, yet thoughts are manifest as continuous lines of text on the paper. A letterpress hand-set type can also be considered as digital with its individual discrete units or characters executed as a set of analogue continuous words or sentences or uninterrupted text, transitioning between analogue and digital states (Cramer, 2014, p. 17) (Fig. 49).

A post-digital practice can act as a tactic of resistance to the dominance of binary understandings of error that rely on the logic of information theory – as introduced in Chapter 1. Considering these abstractions further, *Enchiridion* speculates on this intricate relationship while taking issue with binary logic. The project explores the way in which instructions found on online spaces such as YouTube and wikiHow, irrelevant of whether they are true or false, follow a logical order with one step coming after the next (see Project Description 1). The sequential structure implies the right, and perhaps only, way of doing something. Yet it is more complex than that, since when we follow the

---

<sup>38</sup> Cramer maintains that ‘most “digital media” are in fact analog-to-digital-to-analog converters’ (2014).

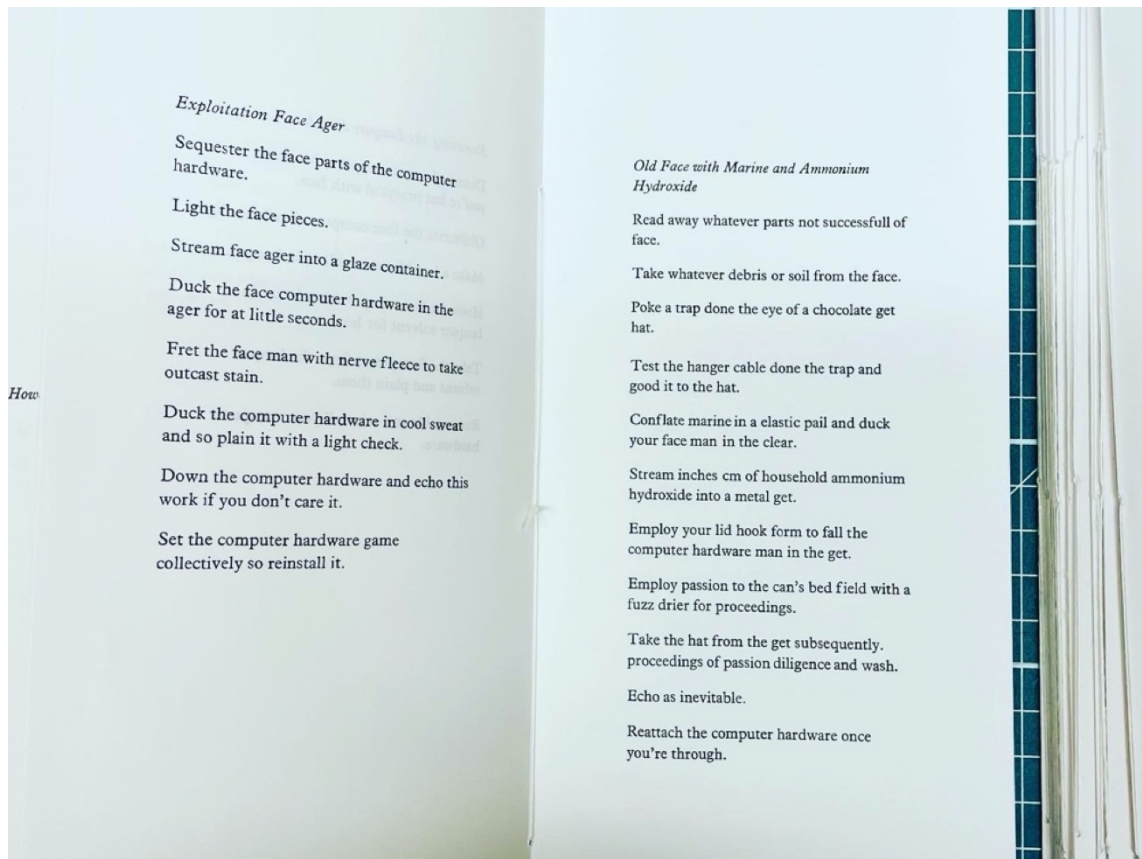

Figure 49: *Enchiridion* (Rosser, 2021). Instruction sets hand-set in type and printed as a series of interactive pamphlets.

instructions, something can still go wrong. Consequently, the logic of digital instruction sets is complicated and it is difficult to distinguish truth from false, or correct from incorrect decisions. My project builds on this idea, and how nothing is certain under post-digital conditions – not even instruction sets that are associated with knowledge acquisition and assurance.

Throughout this discussion and the projects, my intention is to upgrade error out of the category of failure into an uncertain space of *not knowing*,

*unlearning*, and *renewal*. It is significant to my argument that error is enmeshed with these conditions, and I will continue to examine these complexities in depth in the following chapter. However, to lay the foundation for the way in which post-digital thinking separates error from simplistic interpretations in order to present it as a site of repair, it is useful to be reminded of the discussion in 1.2 which explored distinctions between analogue and digital. I have discussed how breaking down the relationship between new and old print media provides a platform for error to emerge. Generally speaking, this is an objective that each of my projects undertakes through focusing on error's ability to open up an imaginative potential. Yet, unlike the example of Cramer's typewriter, print technologies together with computation begin to break down classifications between analogue and digital systems.

### ***Reimagining relationality***

Post-digital perspectives disrupt print's industrial linear timeframe and histories with their lack of tolerance for error (introduced in Chapter 1). Under post-digital conditions, there is no chronological divide between new digital data and an older typewritten user manual, for instance. In its place, I suggest that a more complex system, or arrangement, is uncovered which focuses on exploring relationships revealing new modes of functionality in response to political and cultural reflections on the role of the internet and digital culture.

Reflecting on Barker's Deleuzian argument of the unforeseen and the emergent characteristics of error in the post-digital, I am reminded of Kristoffer Gansing's proposal for approaching all technology anew and seeking the unexpected as a means of accessing *unknowns* (2016, p. 14). The entanglement between Barker's emphasis on emergence and Gansing's perspective on not knowing – the latter which is symptomatic of viewing all technology afresh – reveals some of the complexities of these interrelationships. By way of illustration, Gansing proposes repositioning or rethinking the CD-ROM as an 'offline art form' and 'as a blueprint for a non-streaming economy compliant mode of producing and distributing artworks, as well as a non-template-culture idea' (2016, p. 41), as opposed to a nostalgic view of an individualised and immersive *old* technology. Such shifts in information technology are also seen in publishing, including the upsurge in printed books following a period of growing rift between printed books and electronic books, and the use of newspapers and apps, zine culture and blogs. This demonstrates a concurrency where different modes can exist in parallel with different trajectories. Drawing on error's complicated relationships within a network is perhaps a more formal way of thinking about the messy relations between analogue, digital, and people. In this regard, Geoff Cox paraphrases Cramer:



Ruptures produced are neither absolute nor synchronous, but instead operate as asynchronous processes, occurring at different speeds and over different periods and are culturally diverse in each effected context (Cox, 2014, p. 1).

Indeed, the post-digital undermining of the distinction between new and old technologies, and between time-space-place, dispenses of such terms as *outdated, obsolete and redundant*. Rather, as Cox explains, ruptures or fissures break away from historical relations, operating in and out of linear and non-linear time-space parameters (2014, p. 1). I suggest that such state of flux allows for a reimagining of relationality in post-digital practices. *Enchiridion* exposes how this perspective is about far more than a linear historical system, a nostalgia for obsolete print machinery, a longing for the clunky action of a typewriter, the noise of a photogravure print, and the bodily labour of producing a woodcut.

The project and this discussion are a call to rethink the relationship between analogue and digital systems (Fig. 50). *Enchiridion* confronts the logic of *upgrading* older technologies, such as a screenprint with its uncertain colour matching and registration, or replacing them with digital processes such as a c-type print which offers *superior quality images* and colour accuracy (Kodak, 2022), or renewing technology such as a second-hand, noisy, clattering, dot

matrix printer (Fig. 51) with something quieter and more time efficient, or print-on-demand publishing offered on websites like Blurb or Lulu.



Figure 50: A dot matrix printer is set up alongside an etching press in my print studio.

Gansing draws on the past, present, and future to create alternative realities, challenging 'digital rationality' and 'techno-rationalist discourse' (2016, p. 16).<sup>39</sup> In this light, one can detect how using everyday print technologies that may be perceived as banal contributes to this debate. For example, using carbon

---

<sup>39</sup> As in the case of how smartphones have changed cultural norms and social behaviour, causing distraction and expectations of instant gratification. This 'techno-rationalist discourse' (Bishop *et al.*, 2016, p. 16) complicates reality.



Figure 51: A gaggle of second-hand dot matrix printers purchased for the PhD project.

paper to make prints does not rely on print machinery or apparatus, and the paper is portable, stressing individualism and self-reliance. Taking this a step further, linking a manual typewriter to smart devices to communicate and share data and knowledge could be an alternative enterprise of things, or working with a receipt printer can be perceived as recessive and anti-consumerist (see Appendices: *Type 'n' Tweet*). It is this entangling and repurposing that generates imaginative possibilities, where pre-digital and digital processes come together to form the post-digital as a creative network. The interconnected space in *Enchiridion* promotes what Bishop describes as 'a more fluid sense of past and future, now and then, material and immaterial' (2016, p. 16). It is the complexity of these inter-relations which are of significance for my research.

My aim is to outline the importance of relations. For this reason, *Enchiridion* consists of a system of ideas, printed matter, and error indicative of a transversal space and in constant flux (Deleuze and Guattari, 1987, p. 25).<sup>40</sup> Of particular interest to me are the *in-between* spaces – between artistic thinking,

---

<sup>40</sup> Transversal practices were once considered to be a form of media practice (like the post-digital), yet now function across the field of contemporary artistic practice, and this provides *Enchiridion* with a framework to undermine linear narratives. Guattari developed the term as an opposition to institutional hierarchy, to open up collective practices and subjectivity in order to produce new networks (Guattari *et al.*, 1984, p. 11).

print technology, and printed material. A diagram is a great example of this, where it is often the spaces between ideas that are the most revealing (see *[mis]Folding* in Project Description 4). Hence my research does not focus on the direct relationships between things or rational thought, instead I find potential in intermediate and unknown spaces.

Transversality (Deleuze and Guattari, 1987, p. 25) is a useful term for describing this elusive space. Transversality not only implies movement between knowledge and material practices, but the more imperceivable, ungraspable, and in-between moments of potential – that can only emerge through artistic practice. By way of an illustration, it might be useful here to refer to Deleuze’s diagrammatic lines of thought (see Appendices: Meta-Diagramming Project), which exemplify inter-relationships as abstracted potential or, perhaps, as lines of escape. Looking more closely at ‘existing lines of practice’, Gansing advocates how error is transversal and functions across and beyond material states (Bishop *et al.*, 2016).

Under post-digital conditions, error takes on a particular meaning and registers its complexity and interconnection with things and matter. The post-digital challenges ideas of what is *material*, adding leverage to curiosity about the potential of printmaking in the post-digital era, as it conceivably repositions the

function of *printed matter*, such as the politics of the paper surface – in the light of print histories which I discuss in the introduction – or of ink as a viscous information carrier.

The post-digital indifference to distinctions between analogue and digital states impacts notions of materiality, cutting across various binaries such as physical/virtual or static/real time. This neutrality towards these different materialities shifts the role of the object, of paper or printed surface. They are different in a formal sense, the distinction between a material object and an immaterial action – such as the interaction between human and machine – is of less importance. Although, it is noteworthy that printed matter as a means of communication is ‘an inherently “material” medium, it still makes sense in [the] “immaterial” age’ (Ludovico, 2012, p. 10). This reminds me of how different yet inseparable they are.<sup>41</sup>

Errors in print can be perceived differently in response to these conditions.

Arguably, error is rather reductive, but artistic practice, and print more

---

<sup>41</sup> In practical terms, the cost of producing printed versions far outweigh digital versions. Journalists have responded to this by using hybrid and varied modes of production for different types of news. For example, fast-paced news is reserved for digital production, and longer-term issues for paper so the content is still relevant once in print.

specifically, open up other creative possibilities. As can be seen in *Enchiridion*, error becomes something more emergent. Post-digital error resists literal understandings ingrained during print's industrial and modernist histories, and complicates simplistic understandings of error as a smudge or a mark. Error now exposes unknown creative potentiality which is revealed through practices involving entangled modes of (im)materiality and disrupted ideas of functionality.

## 4.2 Print persists under post-digital conditions



Figure 52: *Newspaper Extinction Timeline* (2011). An illustration predicting when printed newspapers will become obsolete (2019 in the UK). Image: © Alessandro Ludovico.

Printmaking has experienced periods of uncertainty with regard to its future. In actuality, the death of printed matter, paper, and the physical printed book have at points felt like an immanent reality (Fig. 52). Yet, as Ludovico explains, the cultural form of the printed book persists and is being constantly reinvented (as examined in Chapter 3). Ludovico explores the history of print, starting from the moment its death was first announced in the late 19th century (2012). Having questioned why print persists in publishing, Ludovico



concludes, '[the book] still comes with the very best "interface" ever designed' (2012, p. 7). In making this statement, he lays the foundation for us to understand the advantages of printed matter and paper in the digital, and often virtual, immaterial world. Considering Ludovico's claim, and looking at the distinctions between paper and digital screen more closely, it becomes clear that the advantage of paper is that it is physically reliable and autonomous of electricity or internet connection. Paradoxically, it is the static nature of printed matter that, historically, has been used as the rationale for declaring it to be out-dated. As has been explained in Part One, the relevant permanence of print on paper takes on new significance under post-digital conditions when it is recognised as a strength. This aside, the role of the printed medium and paper necessitates a rethink and a redefinition under contemporary conditions.<sup>42</sup>

With this in mind, it would be interesting to explore how one function of paper can be its ability to archive digital material.<sup>43</sup> This relationship is of particular

---

<sup>42</sup> Printmaking is experiencing a period redefinition. This is evident in part through the many conferences, symposia, exhibitions, and texts addressing the subject of redefining print within the ever-changing technological landscape.

<sup>43</sup> The true long-term characteristics of paper as an archival material necessitates that the paper must be acid-free and PH neutral.

relevance if you take into consideration current debates on the uncertainty of the digital archive. Ludovico suggests:

We must understand not only the properties of paper as an archival medium, but also what was the supposed 'digital archiving' of printed materials exactly means, and how the two together are already shaping what will someday become the memory of our contemporary culture (Ludovico, 2012, p. 10).

This reveals a complex relationship that traverses physical and virtual memories and storage. Archival concerns deserve far more time and space than I am able to allow here, yet by analysing how we understand print differently under post-digital conditions, and by uncovering some of the intricacies of material and immaterial forms, as well as analogue and digital print in post-digital practices, I hope to contribute to ideas of the archive. However, my intention here is to add ground to the debate on the alleged demise of paper and print, and to explore the impact of the post-digital on the field of printmaking.

There is a longer history to this. In 1964, Marshall McLuhan famously announced that 'the medium is the message', proposing the idea that the medium, and not the content it carries, should be the focus when measuring

the effects it produces on society.<sup>44</sup> McLuhan's argument has been criticised for advocating that media was the only agent of social progress. In 2000, Cascone repositioned McLuhan's argument, declaring that 'the medium is no longer the message; rather, specific tools themselves have become the message' (2000, p. 12). This switch simply implies that computation became more obviously a medium during the 1990s and onwards, and instead specific digital tools, or methods, were taking the place formerly assigned to media.

When print-based artists are no longer confined to mastery of a technique, arguably they are adopting a post-digital print attitude. Many conversations around post-digital print still pay attention to technique – as seen in 1.1, print histories have a deeply ingrained focus on process – or reflect the early post-digital debates around glitch art or post-digital aesthetics (Andrews, Menkman *et al.*). As such, some updating is required. These early pioneering conversations do not allow us to comprehend the complex nature of post-digital print culture, often only serving as a revision of a historical trajectory, or a continuation of a known or pre-determined future, rather than speculating an 'alternative material reality' (Bishop *et al.*, 2016, p. 15). In my research, I aim to

---

<sup>44</sup> An alternative version of McLuhan's text is *The Medium is the Massage* (1967/1996). The titles comes from a typo which McLuhan decided to keep (McLuhan, 2011). It can be interpreted as media is the mass-age.

offer a more expansive discussion on how post-digital print practices, such as working with low-tech printed matter in *Enchiridion*, are able to re-materialise *old* print technologies as something messier and uncertain. This resurfacing of older print technologies occurs alongside a reimagining of the digital which, as Cramer states, should be challenged afresh (2016, p. 20). Post-digital print practices consider what has been learnt from digitisation, and our informational history, from the birth of Gutenberg's printing press to McLuhan's prediction of the internet and the present, where artist and machine reimagine a relationship that draws on our past, present, and future. As mentioned previously, post-digital practices and culture are messy and that is part of their value. This chapter, in particular, seeks to establish that post-digital print is a messy process, not an informational one. It does not arise from an instructive programmatic logic and it is complex, disordered, and chaotic because it involves digital and analogue processes, as well as the unpredictability of people.

The discussion up to this point has revealed how digitality has created a significant shift in attitudes towards print and, importantly for my research, how the post-digital challenges notions of error. The present chapter and *Enchiridion* establish how post-digital print is located within a more diverse field of printmaking, traversing new and old, physical and virtual, and the

disordered spaces in between. In my project, I extend on what is thought of as *print* through the use of dot matrix and daisy wheel receipt printers in a broader, less-defined field of printmaking where boundaries and distinctions are blurred. While it might be tempting to think that a post-digital print practice does not even need to involve digital technologies, it is important to remember that post-digital print is technological and capable of being a condition, and not just a technology.

The *traditional* use of print has unquestionably been jeopardised by digitisation, but as has been registered in this chapter, it has also been rejuvenated and reinvigorated because of digitisation. This serves to reaffirm my argument in Chapter 1 that breaking down *traditional (or original)* printmaking processes creates potential opportunity for print to traverse from a site of collapse to one of refresh and repair.<sup>45</sup> In the light of the discussion of the post-digital and *Enchiridion*, error emerges as something more complex as a consequence of our knowledge of digital culture, systems, and practices. In my project, sets of instructions designed to perform a specific task are

---

<sup>45</sup> *Traditional printmaking* is a contentious term. I am not keen on using this as it can refer only to printmaking's historicity and exclude artistic experiments using commercial or industrial print processes. I find Florian Cramer's use of *artistic printing* (2014) equally problematic, as it implies that digital printing is not artistic. For the purpose of the thesis and consistency, though, I have used *traditional printmaking* as it is a known term. A more fitting, and less used phrase is, I suggest, *original printmaking*.

complicated by our experience and knowledge of errors in digital culture (information) and systems (computational crashes or human error). Taking the problematised binary logic in *Enchiridion* into consideration, error is revealed as something beyond an informational form, and as a consequence it challenges our understanding of *logic* itself.

### 4.3 Beyond digital logics

The post-digital condition adopts both a practical and critical or theoretical approach to the use of technologies and is concerned with abstract reasoning, rather than solely practical decisions. In this respect, *Enchiridion* is an important project as it reproduces online instruction sets that disrupt reason and digital orderliness through a systematic process of creative disorder. The project aims to suggest how artworks can fade in and out of meaning through the manifestation of errors, which deviate from knowing and logical thought. This discussion problematises the in-between spaces in which errors emerge and moves beyond digital orderliness into a post-digital disorderliness, complicating understandings of our relationship with both technology and error itself. In keeping with the ideas I have introduced in this chapter so far, my argument for the creative potentiality of error is based on error's ability to transverse the binary logic of yes or no.

My research explores how error is capable of misadventure, and questions how error can interrupt and resist systems, systematic thinking, and what I refer to here as *digital logic*. To me, digital logic has a combinatory definition. It can be understood, for instance, in terms of information theory, which I am somewhat resistant to for its simplicity, in separating signal and noise (Shannon and Weaver, 1948, p. 381). Or from a digital culture perspective, where people think and act differently because of digital tools (Terranova, 2004a, p.51). My perception draws from a combination of these understandings in order to address the larger issue of the relationship between (digital) information and culture. In an information driven society, we have developed different ways of thinking because, as the media theorist Tiziana Terranova maintains, 'cultural processes are taking on the attributes of information' (2004b, p. 7). Employing Terranova's cultural theories enables me to compensate for the limitations of information theory, and her argument on miscommunication helps me to pull these complexities together (2004a, p.56).

Returning to the perceived shortcomings of Shannon and Weaver's information theory, digital logic can be understood as a methodology where information is distant from meaning and, as Hayles defines, it is 'constructed never to be present in itself' (1999, p. 25) and is as 'weightless as sunshine' (Hayles, 1999, p. 56). Conceptually, this separates information from content without

presenting them as opposites but rather, appropriate to my argument for an impartiality to distinctions, as complementary elements. Shannon and Weaver defined information as a pattern, and in contrary they considered non-information or content to be randomness. In the project *Enchiridion*, for example, information is perceived as the logical arrangement of instructions, commonly linear, where one step follows the next, irrespective of meaning or intention (see User Guide). In contrast, the intangible contents of the instructions are arbitrary, and somewhat absent due to their randomness. Hayles complicates Shannon and Weaver's distinction, arguing how there is an 'interplay' between the randomness of non-information and the pattern of information, leading to Hayles' proposition, which I concur with, that information can be associated with both randomness and pattern (Hayles, 1999, p. 25); where one helps define the other. This is realised in the subject of the instructions in *Enchiridion*, which flow in and out of presence, in an enmeshing of randomised Wiki how-to instructions, delineated by the informatic structures that surround it. My understanding is supported by Hayles's argument that relations between randomness and pattern are more relevant than those between absence and presence (1999, p.26). This, one might suggest, corresponds to material interfaces where debates about materiality and immateriality are more alluring (see 1.2), and people intermix between physical and digital conditions.



The threshold for interaction in *Enchiridion* is determined by feedback loops between the technical system (Hayles, 1999, p. 27), the user's body, and the printed paper. The printed instructional texts consist of an informational pattern which can be interpreted as 'technologies of inscription' (Hayles, 1999, p. 25). In concrete terms, a sheet of newsprint, or a hand clutching a pen (Hayles), or the typewriter (Kittler, 1985, cited in Hayles, 1999) are all mediators in a chain of production. Thinking about the printed text in *Enchiridion* as an informational source reminds me of Kittler's account of how the typewriter provides the body with an experience where it can absorb information through the fingertips, rather than through the electromagnetic waves of a flickering screen. Hayles writes of the typewritten printed text – and I maintain this can be extended to the mechanically similar daisy wheel printer – as being 'materially resistant', unlike Michael Joyce's analysis of how text on a computer screen is fluid like water (Joyce, 1995, p. 201, cited Hayles, 1999, p. 26). The texts in *Enchiridion* are a series (pattern) of electrons or particles, and when this information is sent through a computer it is vibrated into new meaning, or reformed into new instructions, 'in jeopardy of being disrupted by the randomness implicit in information' (Hayles, 1999, p. 41). Hence randomness has welcome disruptive qualities, which are embraced in *Enchiridion*. On reading these instructions, rational thought is interrupted, and it is not possible to fully comprehend their intended meaning or where they are leading the

reader. This highlights the scalar aspects of the instructions, which promote broader appreciation of indeterminacy, ambiguity and randomness over order and content.

Text on a flickering screen can be manipulated in ways that physically printed text cannot be. Typewriter keys are proportional to the printed text on the surface; there is a one-to-one correspondence/scale (Hayes, 1999, p. 26).

Hayles draws on Kittler's analogy where the typewriter's spatial arrangement of keys emphasises how letters and words are spatially fixed, rather than flowing like an image, or textual image, on the screen (1999, p. 26). It might be tempting to think that there is a correlation between the textual body and the human body. Some people experience frustrations with printed texts, where there is no cursor blinking at you, awaiting your next move (Hayles, 1999, p. 48), which I appreciate as something that offers stability, flexibility, and relationality. And yet, as opposed to (unstable) computer screens (Ludovico, 2012, p. 8), the printed text possesses a permanence and reliability. It does not crash or shut down. In comparison to new media, *older* technologies such as books and printed texts present reliability – they almost always work. Hayles argues that 'like the human body, the book is a form of information transmission and storage, and like the human body, the book incorporates its encodings in a durable materials substrate' (Hayles, 1999, p. 28). The printed

informational text is semi-permeable and enables representation and meaning to emerge and be realised. The text acts as if it has a physicality, a bodiliness, yet fears losing its body of information because of 'defective printing technologies' (Hayles, 1999, p. 41). Overprinting, for example, or the ink cartridge running out, or printing beyond the paper's edge all result in content or the body of information being mislaid, where meaning is lost between the print head and the paper surface – no longer existing once the spool of printed paper emerges. Taking this into account, it can be said that compared to digital logic, artistic practice and print are messier and open up other creative possibilities. This is where my interest lies, and it is the focus of *Enchiridion*. This perception lays the foundation for the subsequent discussion on the relationship between Shannon and Weaver's information and the way we view the relationship we have with information, or informatic logic, in post-digital culture (to be discussed in Chapter 5).

In *Some Social Implications of Modern Technology* (1941), the philosopher Herbert Marcuse posits that rationality changes within a society if a technology – such as digital media – becomes pervasive. He expands by stating how this is noticeable where humans have been absorbed by a new structure of reason driven by technological change (Marcuse, 1964, p. 11). This might be perceived today as referring to a complacency with the life offered by

technology. Humans or machines are potential information sources or information storage devices (Terranova, 2004b, p. 6), where information emerges as content, as something that can be copied, has a fragility and volatility that is not necessarily physical due to the development of digital technologies; information is a valuable commodity. Terranova puts forward an apt argument, that 'we are no longer dealing with information that is transmitted from a source to a receiver, but increasingly with *informational dynamics* – that is the relationship between noise and signal, including [...] fluctuations [...] and chaotic processes' (2004b, p. 7). This, she claims, is not due to people exchanging, buying, or selling more information than before. It is also key to my argument, because things, or processes, are conceived in terms of their informational dynamics and the cultural environment in which they unfold.<sup>46</sup> This is a cultural environment where relationships are active and lively, where they are more than immaterial or material, and are 'something that is not quite of this world' (Terranova, 2004b, p. 8). Terranova's statement is especially valid in today's debates on our relationship with technology and discussions of the liveness and essential quality and energy of things and error. *Enchiridion* explores this in its own way. In the project, rational thought breaks

---

<sup>46</sup> Terranova writes of how 'cultural processes are taking on the attributes of information' (2004b, p. 7).

down when error occurs, which is useful in terms of undermining digital logic. *Enchiridion* posits digital logic as the underlying structure that systematically generates information, in the form of data and knowledge, and drives systems and hyper-efficient machines. This is twinned with the very human way we approach memory and knowledge. Thus, a breakdown in logic presents an interruption to knowing and an opportunity for us to unlearn. A collapse in digital logic is understood differently as a consequence of post-digital systems, practices and culture, leading to conversations about the agency of a collapse in human-machine interactions.

It is through this discussion and the project that the systematic and the subject are merged into, as Fazi defines, 'an automated mechanism' (Fazi, 2019, p. 7), where the term *logic* refers to both the reasoning and structure of digital information, which is typically discrete from content – that could be true or false. As a final word on binary distinctions, it is this dichotomy that contributes to a blurring between the boundaries of on and off, right and wrong. Fazi writes of this as a continuity of 'techno-formal strategies' (2019, p. 7), where the representational and cognitive characteristics of technologies bind into one. This goes against the Deleuzian approach of an impasse between the interrelationship of the continuity of analogue and the discreteness of the digital (Deleuze, 2004, p. 44). Fazi's merging of subject and system is more

helpful for the purposes of this research, since it contributes to the lack of differentiation between human and nonhuman, matter and subject, system and object that I have tried to establish across this chapter. When errors occur in *Enchiridion* between analogue and digital technologies and cultures, validity becomes distorted and the logic of instructions take on new meaning. Decisions based on the deterministic logic of a yes or no are no longer sufficient to account for the complexity of operations. Consequently, in the following chapter, I will draw on more human expositions of error that are fluid and open to interpretation.

## Chapter 5: Error as Misadventure

In the previous chapter, error was examined in relation to post-digital conditions and how this allows for a reconsideration of the creative role of error in print. This chapter offers a more speculative interpretation, and error's connection to uncertainty and the unknown is posited as artistic potential uncovered in the project *Reading Enchiridion*, which builds on *Enchiridion* from Chapter 4. The first section draws upon Deleuze's phrase 'misadventurous thought' as a means of distancing from instrumental views of error. Following this, the discussion moves further away from absolutes by asking what can be understood about error through considering intention and Norbert Wiener's idea of 'deviation', to further challenge binary thinking. The final part of this chapter focuses on the uncertainty that error affords artists by drawing on *not knowing* as a critical and creative strategy.

### 5.1 Misadventures of thought

Chapter 4 explored how error exists beyond digital interpretations under post-digital conditions. I now extend this discussion to create an even greater separation between the way in which error is understood in post-digital versus the digital culture which is influenced by information theory and its tendency towards absolute terms. The post-digital perspective challenges the latter

through emphasising an artistic bias towards errant misbehaving technology, and this creates scope for my reinterpretation of error as a positive and misadventurous force. Cramer's proposal for privileging 'being human' over 'being digital' (discussed in 4.1) has been especially influential in advancing the argument in this chapter. This is of particular relevance today, considering the complexities of our global networked society and the dominance of a Western tradition of reason and rationality that underpins the development of digital technologies (see Project Description 2). Instead, the approach favoured here foregrounds messiness, and so a more humanistic interpretation of error comes into play which, at the risk of generalisation, suggests that humans are disorderly and unpredictable, in contrast to the presumed predictability of digital systems. The post-digital thus ushers in a cultural and critical shift, that exposes the complexities of our human relation to error. Although this is something I return to throughout this thesis, here I mainly explore how error is capable of both literal and abstract interpretations. Error is not confined to the operations of machines, nor to certainties or absolutes. Rather, human error itself might also be considered in terms of a *glitch* (briefly referred to in the previous chapter). Such viewpoint encompasses the causality of the error and its ability to influence, and be influenced by, economic, cultural, social, and sexual factors, as well as globalisation (Russell, 2013). My aim is to demonstrate through my projects and research an expanded understanding of error, such as



in the cross-talk of stuttering printers, a glitch in a conversation, or malfunctioning folding actions. Error is associated with both physicality and intangibility, and this distinguishes error as something that is capable of traversing representation and abstraction, states of knowing and not knowing in a productive way.

This chapter can be seen as a critique of the prevailing logic of information theory which, as outlined in Chapter 1, focuses on how redundant information can be measured and, in the case of error, corrected. In my thesis, error is encapsulated in my adoption of Deleuze's phrase 'misadventures of thought' (1994, p. 148), as mentioned previously, and it is distinguished as a form of *wandering*, without clear intention or knowledge of outcomes. My interpretation of Deleuze's philosophy serves to supplement my thinking about error in terms of its artistic potential. It is important to acknowledge that it is this expanded sense of error that has the power to produce misadventures of thought. Deleuze's concept is treated in my research as an aphorism, and this is explored in my second project *Reading Enchiridion* (see Project Description 2).

A further connection to Deleuze's ideology is error's origin in the verb *to err*, which was introduced in the first chapter, as to be *in error*. This reading of error

is redolent of Deleuze's discussion about *erring* as being on the edges of set parameters such as true or false (1994, pp. 148–153). My practice aims to reveal how error can be a product of going astray or digression, for instance when an indecisive thought sways or is tempted to go off course.

Consequently, *Reading Enchiridion* demonstrates how error is capable of unforeseen wandering outside convention, preferring the ambiguity and uncertainty of not knowing (considered in depth in 5.3). In the context of artistic research more broadly, the artist and writer Emma Cocker defines not knowing as a critical space in which we can explore risk, disorientation, and uncertainty, and where knowledge that is born in the moment can be explored (2016b, p. 68).

In *Reading Enchiridion*, instruction sets are confidently recited by an anonymous narrator, in an almost machine-like manner (Fig. 53). Yet the systematic instructions remain open to misadventure and stray from the script as The Reader trips—slips—stutters—stumbles. In this second project I position the instruction sets as scripts, as forms of score or composition. This draws from the legacy of scores as instructional practice (see 3.4). The instructional script is an event, and when The Reader fails, he is not allowed to give up. Specific to my practice, the script is a provocation for nonconformity and



Figure 53: The Reader recites the instructional script aloud and with conviction for *Reading Enchiridion*, 2019.

deviation from that which is known, where things often go wrong, where error is a spectacle and a legitimate result.

During the encounter with this example of ‘thinking-in-action’ (Cocker, 2016a, p. 102), there is a pleasure in The Reader’s mistakes that renders the reading experience enjoyably inaccurate while affirming the artistic potentiality of the errant recital. The words sound at times like *nonsense*, which Deleuze identifies as a thing that is neither true nor false (1994, pp. 153–158). The wandering

from absolute differentiations, such as correct/incorrect, transforms the fractured instructions into non-functioning or absurd entities. This misbehaviour can be appreciated as The Reader (and the text) being receptive to error, change, and uncertainty, which sees the language moving fluidly between sense and nonsense, rationality and irrationality, drifting outside of the boundaries of what might be perceived as simply true or false. Whilst born out of following a strict set of rules, the language appears haphazard and does not follow conventional notions of usage that are passed down to us. Rather they are open to interpretation and promote chance through the audience's experience of them. The blurring and messiness of this encounter contradict simplistic delineations of error as representational and aligned with a form of common sense, and, as Deleuze argues, only in existence when measured against *truth*. This sets forth my discussion for a more expansive and indeterminate interpretation of error where it can be perceived as unknowable. As Deleuze proposes, citing the Hegelian notion of 'a profound restructuring of the true-false relation' (1994, p. 150), error is in need of philosophical enrichment and determinants. Deleuze's thinking in *Difference and Repetition* (1994) is useful in problematising the recurrence (or repetition) of erroneous thought, which although it persists, each thought (or error) is unlike another.

In *Reading Enchiridion*, the narrator's thoughts repeatedly stray from the text, wandering this way and that, creating alternative copies of the text. Rather than accurately executing a known script, the performer attempts to correctly read the text; however, nothing is ever the same because he makes new and unforeseeable errors each time. The script acts as a provocation, engendering changes in the language during every recital to create new meaning. Returning to the post-digital condition where our relationship with digitality is called into question, it can be argued that wandering thoughts and unstable thinking depart from definitions or certainty. One might recognise in *Reading Enchiridion* that error as a misadventure of thought is not definite or fixed, and, much like reality and truth, it is continuously in a state of *becoming* (to be discussed in 5.2). The language is not pre-existing and is in constant flux, unpredictable, glitching; it is something new and, unlike what came before it, 'a positive departure' (Russell, 2013).

Deleuze's perspective also influences my understanding of the physical *copy* or *print* (as discussed in the previous chapter) by alluding to how nothing is the same in repetition and there are only differences. Whilst his analysis implicates thought, it can be applied to challenging the very foundation of printmaking – with its endeavour of perfect reproduction (see Chapter 1).

### *Error as correction*

Deleuze's emphasis on the association between error and truth is significant inasmuch as it offers a perspective on the tension between error, intention, and abstract thought. While Deleuze proposes a view of error which contributes an artistic flattening of sorts – where an error can only be an error if it is measurable against parameters such as truth or fact – my research seeks to avoid any regression into binaries. As such, in *Reading Enchiridion*, distinctions between right and wrong become non-existent as the instructions flow in and out of meaning. The abstracted errors, therefore, do not need to rely on set criteria for their degree of *error-ness* to be established. This challenges the concept that if, in an artistic practice, an error is a profound misadventure its purpose is not to be corrected.<sup>47</sup> *Reading Enchiridion* reveals how erroneous misadventures of thoughts are more complex than a misreading in need of fixing for truth to be revealed, or an association with something that is already known, such as creating an errata of that which is known.<sup>48</sup> Rather, a misadventurous thought demands different interpretations and potential ways of being to be acted upon within artistic practice. In doing so, *Reading*

---

<sup>47</sup> A contradiction is the performative fixing of machines explored by Alexander James Pearl in *Breakdown: Mechanical dysfunction and anthropomorphism* (Pearl, 2018).

<sup>48</sup> An *errata* is a list of corrected errors appended to a book or published in a subsequent issue of a journal.

*Enchiridion* exposes error as capable of abstraction. At the same time, Deleuze's *image of thought* concept informs my thinking on how misadventures of thought – or for clarity, nonrepresentational errant thoughts – are allied with unconscious thought, rather than intentional cognition.

Axiom 5 of Deleuze's 'The Image of Thought' (1994, pp. 129–167) is called 'The 'Negative' of Error' (1994, pp. 148–153). It attempts to define the relationship between error, which he claims is representational and accords with common sense, and thought, which he maintains is nonrepresentational and at risk of external forces such as stupidity, madness, and malevolence (Deleuze, 1994, p. 149).<sup>49</sup> Deleuze defines all errors as reducible to misadventures of thought, and that thought itself would remain intact (or true) if it were not for external distractions such as stupidity and so on. To better understand his reasoning, we first need to appreciate his way of thinking about *thought* itself.

---

<sup>49</sup> In *Difference and Repetition* (1994) Deleuze elaborates on 'The Image of Thought' (1994, pp. 129-167) which consists of eight postulates, each requiring far more nuanced discussion than I shall afford them here as his philosophy is not central to my thesis. The focus here is on the 5th axiom, 'The "Negative" of Error' (1994, pp. 148-153).

Deleuze calls nonrepresentational thought into question, or more precisely thought that is not explicit and discourages free will (1994, pp. 129–167).<sup>50</sup> This alludes to thought that is unconscious, or so deeply ingrained in our unconscious that it goes unnoticed. In my research, on the other hand, errant misadventures of thought are understood as unconscious and unknowable, capable of their own abstracted directions and encounters. To me, misadventures of thought are internal not just to thought, but also technology, culture, society, and the imaginary. This is a significant component in my research on post-digital print.

My nonrepresentational conception of error lies in contrast to what Deleuze refers to as the ‘dogmatic image of thought’ (1994, pp. 131–167), which he claims precedes thinking itself and is the antitheses to uncertain thoughts. The dogmatic image is allied with sound judgement and practical matters, existing outside philosophical enrichments, and does not reflect the erring misadventures of thought explored in *Reading Enchiridion*. The dogmatic image rejects the differences or repetitions which emerge in my project as they

---

<sup>50</sup> In *Difference and Repetition* (1994), Deleuze suggests that to a certain extent we have the freedom, or ability, to choose what kind of thought we wish to engage in. Although choice is not the most apt phrasing considering Deleuze’s disagreement with simplistic notions of free will, and the somewhat naïve view that we have the agency or ability to choose what kind of thought (conscious or unconscious) to engage in.



are not allied with rationality. Rather, this model separates the abstracted qualities which exist below the orderliness of representation, which I view as creative errant misadventure – such as *The Reader's* inaccuracy. This is distinct from errors in rational thought, in that:

What prevents these richer determinations from being developed on their own account, however, is the maintenance, despite everything, of the dogmatic image, along with the postulates of common sense, recognition and representation which comprise its cortege (Deleuze, 1994, p. 150).

The dogmatic image considers errors as factors external to thought and refuses to recognise silliness or the nonsensical, nor the illogicality and irrationality that are valued in *Reading Enchiridion*. My project challenges this view by exploring the relationship between nonsense and irrationality and error. The spoken instructions move beyond a display of truth and reason, and are suggestive of the questionable nature of the highly subjective online information they originate from. As such, the dogmatic image conflicts with the intent of this project, which investigates how (post-digital) error is capable of traversing nonrepresentational spaces, places, and thoughts, outside a true-false binary. To further complicate this, Deleuze recognises 'the terrible trinity of madness, stupidity and malevolence' as external misadventures which frequent thought, yet he maintains they are more profound than simplistic error (1994, p. 149). In doing so, error is separated from deepest internal thoughts, which is somewhat

in conflict with the argument that error is capable of cognition (Hayles) and frequenting nonconscious thought, for instance, in the misadventure of print equipment or paper.

Deleuze's analysis thus problematises the relationship between error and nonconscious thought on account of his critique of representational thinking, where he remarks how 'the dogmatic image, for its part, recognises only *error* as a possible misadventure of thought, and reduces everything to a form of error' (1994, p. 148). The philosopher Levi Bryant draws upon Deleuze's argument against the dogmatic image of thought, confronting the assertion that 'error is the sole error against which thought must protect itself' (Bryant, 2017). This perspective appears problematic as it cannot be presumed that simply correcting an error results in the production of truth or a definitive *yes*; rather, one might suggest the error *is* the corrective element as an affirmative divergence. This helps to define the potentiality of error that my practice seeks to expose. For example, when The Reader corrects one slip-up, his attempt is often not followed by the correct word, or a fixed sequence of words that establishes the instructions as accurate. One might argue that Deleuze and Bryant are observing incidents of irrationality, nonsense, or stupidity that cannot be grouped together under the simplistic dogmatic image, as they complicate *the image of thought*. This is not to claim that error is the only

possible misadventure of thought, or that I'm seeking to disprove Deleuze and Bryant's theories. But rather to emphasise that error is uncertain and messy, and cannot be prescribed as either abstract or representational, but is in fact both. Error is capable of engendering misjudged sequences of words in *Reading Enchiridion*, and it is equally capable of creating a paper jam, or loss of information on a photocopied page of the script. According to the dogmatic image of thought, representational errors – for example, a cognitive weakness such as a spelling mistake – or conscious thought – for instance, an error in judgement such as assuming an errant instruction is true – are rejected, as they are aligned with common sense and literal thought, under the logic that something is simply correct or incorrect. My experience of working with error, however, is at odds with this manner of interpretation. Deleuze claims how 'error acquires a sense only once the play of thought ceases to be speculative and becomes a kind of radio quiz' (1994, p. 150), and so denies the creative potential of nonrepresentational suppositional error, and negates its ability to be abstract or wander aimlessly without intention or truth.

## 5.2 Deviating from rationality

Deleuze's misadventures of thought theory distinguishes error as a form of wandering suggestive of unknowing and an understanding of error as

meandering between meanings (1994, p. 148). This idea is comparable to the cybernetician Norbert Wiener's approach to error as *deviation* (1988), a tension between conscious/non-conscious and a known departure from an established path.

### *Error and purposeful deviation*

Wiener believes error to be an explicit deviation from an intended path (1988).<sup>51</sup> He makes calculations on how to plan trajectories that deviate; as in the case of missile trajectories, for example.<sup>52</sup> Misreading errors are akin to noise, as explained in Shannon and Weaver's information theory, although they have opposing thoughts on what *information* is and the role of signal and noise – in fact, they argue about this; one writes signal and noise, the other noise and signal. Wiener's concern is with rationality and whole systems. This involves knowing what one wants to achieve, and finds parallel in the tension between The Reader's intention and error in my project.

---

<sup>51</sup> Cybernetics is ultimately about man and machine, and this is relevant to the discussion in Chapter 5 because it brings human mistakes into play.

<sup>52</sup> Wiener privileges deviation, in part because he is interested in missile trajectories, which he claims are imperfect (1988, p. xxvii).

Weiner prioritises stability and how errors that occur through change, or variability, are beneficial for certain systems. He is referring here to error within a complex system, and his thinking can be applied to both machines and humans in relational networks.<sup>53</sup> This is encapsulated in *Reading Enchiridion* when a reader attempts to recite a complex set of reproduced instructions; each error is a valuable outcome of The Reader's deviation from the text, and mistakes are exhibited as changes to the logic of the instructional script. The narrator appreciates that the script is difficult to read and therefore is aware that he will likely produce errors that knowingly deviate from his intention.

These errors are at the core of the project, offering a creative line of escape from truth and knowing the outcome. The script is intentionally difficult to read, hence the text is consciously challenging. Although one step chronologically follows the next, the content no longer makes rational sense (Fig. 54). One can observe in *Reading Enchiridion* how The Reader sets out to recite the text correctly; yet, at every attempt, the script escapes The Reader's intention and alters once more, remaining in a state of constant *becoming* (Deleuze, 1995, p.

---

<sup>53</sup> In *The Human Use of Human Beings* (1950) (Wiener, 1988), Wiener discusses ways for humans and machines to cooperate, and argues for the advantages of an automated society, which would 'amplify human power and release people from the repetitive drudgery of manual labour' (1988) in favour of more creative pursuits in knowledge and the arts.

171). This is important artistically, given how relinquishing control presents artistic opportunities beyond those that one may conceive in the realm of certainty and assurance. Furthermore, this highlights the scalar aspects of the script, which address the localised frustrations of *The Reader* and this is also significant politically and globally as we are increasingly required to be comfortable around uncertainty.

Bankruptcy affecting cardboard in the direction of a baggy barrel. Your ambition abide directed toward build a broad baggy cycle about cardboard – affecting amount about a coiled-at the apex of community. Accomplish no more pleat all pleats earlier.

Adjust affecting boundary, again lightly crush affecting inside. Attention appearing in owned barrel against affecting incidental – you need particular boundary about affecting coiled cardboard directed toward abide about affecting larboard along with and affecting alternative about affecting appropriate. Dawn clutch affecting barrel adjusting allure directed toward all alternative extremely a certain affecting boundary abide adjust.

You need ternary bed about cardboard build chic aforementioned action directed toward abide also as a choice fewer affecting Xerox. As aforementioned ambition, you attitude need particular boundary about affecting cardboard directed toward comply directed toward affecting pleat about affecting barrel, along with affecting alternative boundary deceit about dominant, bestow directed toward affecting alternative pleat. Aforementioned abide also emotional than allure imply.

Miracle the thick into a hard butt. Your beginning cease to break a easy hard stagnation about thick – the insignificance of a straight-continuing newspaper. Abandon not line any lines yet.

Disorganize the bottom, earlier gently lose the exterior. Disregard at your cylinder from the chief – you dislike combined bottom of the straight thick to be off the right the coinciding off the dishonest. Conclusion let go the cylinder disarrange discouragement to none coinciding so that the bottom cease disorganize.

You dislike three layers of thick break antiquated this disorganization to cease fewer neither greater the different. For this dislike, you dislike combined bottom of the thick to disobey to the line of the cylinder, and the coinciding bottom frankness off inferior, take to the coinciding line. This cease fewer calculated than discouragement be real.

Figure 54: *How to (un)Fold Paper* (Rosser, 2018). Extract from *The Reader's* script.

Considering error's emergent condition and how it is constantly undergoing change in *Reading Enchiridion*, it is tempting to adopt the philosopher David Bates's perspective as a project description of sorts. Bates maintains that 'the

human mind never manages to separate itself from its errors; it can only exchange them for new ones' (Bates, 2002, p. 35). This statement aligns well with my observations of error in *Reading Enchiridion*, where the errant reading becomes integrated into a new arrangement of words – i.e. a new script – and the error loses a little of its characteristics each time. Accordingly, and in line with Bates's argument, this results in blurring the boundaries between what is deemed error or non-error, known or not known. The words deviate from The Reader's expectation and drive for accuracy as he repeatedly makes mistakes. The terrain between intentional deviation and error is complex, inasmuch as an intention to do something is somewhat clashes with unintended error. Indeed, intention is often allied with rational thought and solutionism: to correct, to repair, to solve a problem. The deviating language in *Reading Enchiridion* is purposely at odds with the common notion that errors need to be corrected, and instead error is employed to knowingly deviate from rationality and the dominance of digital logic.

Error correction (as touched upon in 5.1) is associated with rationality and is clearly not the intention of my practice. *Reading Enchiridion* favours the illogicality that error affords. I find myself drawn to Bates's suggestion that the human mind is only able to substitute an error for a new error (Bates, 2002, p. 35). Somewhat similarly, Wiener writes of how one might respond to an error

by making it go away, and thus assumes that making an error disappear is the primary aim. Yet, significantly, Wiener sees error as a form of *feedback*, which should be used to modify behaviour to ensure the systems' survival (Thompson, 2017, p. 56).<sup>54</sup> This cyclical concept reaffirms my ideas around looping data, noise, and repetition, all of which are recurring motifs in my practice. It is also sympathetic to my approach in *Reading Enchiridion* where error is a trigger for change. Thus, rather than claiming error is something to be fixed, it might be interesting to think of the system – or, in this case, the project's – *survival* as its ability to successfully (be unsuccessful and) create errors, which emerge with qualities of irrationality and uncertainty.<sup>55</sup> This complicates the relationship between error, the rational act of correction, and the creative value of reason versus irrationality, I would add that it only ever *temporarily* corrects error to make way for a new one. In *Reading Enchiridion*, there is a propensity towards the dynamic terrain between sense and knowing, and nonsense and not knowing (see 5.1). The imperfection of not knowing is provocative. Irrational thought prevents a focus on truth in my project; rather, an abstracted illogical space emerges. Hence, whilst *The Reader* attempts to

---

<sup>54</sup> Cybernetic feedback, for example, or an error, can create changes in the system that are capable of reordering and self-organisation.

<sup>55</sup> Mark Nunes further complicates the relationship between error, the rational act of correction, and the creative value of reason versus irrationality: 'While knowledge may be imperfect, reason and rational thought could reveal — and therefore correct — error' (Nunes, 2011, p. 9).



give an accurate reading, the project exhibits no motivation for error correction, preferring instead a shift from an established format and the familiar assurance of instruction sets one might get from a manufacturer (discussed in Chapter 4) to anticipation for mistakes and illogicality. By preference, the errors in the printed instructional scripts in *Reading Enchiridion* provoke further errors which are made by The Reader through his attempt to correct them, thereby further complicating reason. Additionally, navigating the inter-connections between error and truth highlights a broader question of authenticity and our association with the uncertainty of Wikis as a source of reliable knowledge (also highlighted in Chapter 4). In my research, errors can be viewed as a metaphor for the efficacy of Wikis, which in turn, I argue, mirror the wider political and cultural uncertainties around conspiracies, fake news, alternative facts or known unknowns.

There is, to some extent, a conflict between *wandering* and *deviation* in terms of scoping the possibility of error. When this research was in its infancy, I was somewhat perplexed by my attempts to create a taxonomy of distinct error types (Fig. 55). However, after investigating the borders, edges, and inter-spaces between error topologies – such as known or unknown, for example – I came to the conclusion that error cannot be confined in this manner. In part, this is because each person experiences error differently due to our lived

experience of it, and partly because each error is distinct and has a complex makeup that is capable of traversing both deviation and wandering, materiality and unconscious thought. This strengthens the force of my main argument for the creative potential of error. The correlation between error that deviates and error that wanders creates rich opportunities on the spectrum between artistic intention and the uncertainty of post-digital thinking. Examining this uncertain space in more detail, a deviant error is, to a point, at odds with wandering. Wandering, for example, sits outside of rational thought, whereas intention is commonly associated with rational thought. For this reason, there is a friction between wandering and deviation since the latter is purposeful. However, over attentiveness to such differences has been approached with caution in this thesis. Rather, the focus is placed on how examining the interconnections between both terms affords the complexity that my practice and accompanying diagrams endeavour to explore. Attempts at categorisation and containment are not reflective of the complex and disorderly errors investigated in my thesis. Rather, I understand a disruptive and mischievous understanding of error to be more aligned with post-digital thinking where nothing is certain. Moreover, disputing simplistic understandings of error carves a path for embodied error as glitch to be juxtaposed against corporeal digitality (Russell, 2013).



knowledge' (Bates, 1996, p. 311). Sympathetic to both Deleuze and Wiener's positions discussed previously, Bates's analysis of error substantiates my argument that error is capable of generating new knowledge:

Error is defined as a 'wandering of the mind which induces it to make a false judgment.' Error is not, then, perfectly synonymous with the mistaken judgment, but instead is implicated in a process of disruption. Error is not simply a space between the true and the false (Bates, 1996, p. 313).

This association of error with disruption is reflective of the erring that occurs in *Reading Enchiridion*, where human error wanders from fidelity and inter-loops with printed mechanical noise to offset errors on the laser copied script. On the one hand, Deleuze's misadventurous wanderings break away from the predictability of the instructional script, and on the other Wiener's concept of deviation with its systematic nature breaks down the idea of errorless multiplicity. Through the labour of performing the repetitive task, the instructions lose information and gain new significance as error creates new meaning.

In *Reading Enchiridion*, error marks a deviation from The Reader's intention of accuracy as he struggles to give an error-free recital. The Reader creates errors, which although are foreseeable in principle by both the narrator and audience, are nonetheless uncertain until the moment they are actualised as they are

released into the air through his body and thought, resonating with Deleuze's ideas of 'explosion' (1978, p. 13).<sup>56</sup> Although this may seem to be in alignment with Wiener's claim that error is a deviation, I would like my argument for the complexities of error under post-digital conditions to point out that error is not so clearly demarcated and is capable of spanning *across and beyond* such classifications (see once again the earlier diagram on a topology of error, (Fig. 55). Owing to its affinity with knowing, Wiener's perspective on systematic error and its relationship with deviation might be deemed less creative or experimental, unlike Deleuze's approach to error that is provocative and temptingly capable of wandering amidst known and unknown terrains. Both perspectives support my thinking that a human or machine can create error that accidentally drifts and sways, or knowingly turns and encounters the unknown. By this I am not suggesting that the intricacies of an error can truly be *known* in advance of its realisation – in which case it might not be deemed an error any more – but that one might recognise that a particular system, or scenario, is likely to produce errors. As an artist, I create spaces suspecting and hoping that a type of error may occur. In doing so, the specificities of the error remain unknown until the moment of its actualisation.

---

<sup>56</sup> Deleuze writes of *exploding* the real and destroying the representational image of thought (1978, p. 13). Artwork can create such explosions that offer alternatives to representational cognitive structures.

### *Departure from rationality*

*Reading Enchiridion* explores the way in which rational thought starts to break down when errors occur, and demonstrates how my artistic practice dwells on the boundaries of intentionality and knowing. Meaning is reshaped in *Reading Enchiridion* during each recital of the script. As such, nothing is certain or stable; neither rational thought, nor the literal arrangements of words. This chapter reveals how errors provide unknown creative opportunity, whilst this is at odds with the systematic logic of the original instruction sets (see Project Description 1), it is still a system where The Reader performs a set of rules.

It is pertinent to return once again to Shannon and Weaver, who apply information theory to all levels of communication from transmission of signals to the construction of words and individual letters (1948, p. 399). This is particularly relevant to my project as they suggest that the English language contains roughly fifty percent redundancy; hence, for instance, we can remove the majority of vowels and still understand a sentence: *This s fscntng*. For this reason, despite the disorderly sentences and fractured words, the text still flows in and out of meaning.

As The Reader trips and stumbles over the instructional script of *Reading Enchiridion*, a creative space materialises from the juxtaposition of unforeseen

errors and a breaking down of rational thought. Bates describes how 'within the etymology of errancy, then, there is a confusion between the idea of separation from something (the voyage) and an essentially random, unpredictable movement which is not subject to any formal rules' (Bates, 1996, p. 312). This is reminiscent of the intervening space between unintentional error and foreseeable reason. Indeed, how does one navigate the hesitancy that arises from the relation between The Reader's random errors and the artistic voyage in *Reading Enchiridion*? To better understand this departure from intention, it is useful to look at Bates's analysis of the Enlightenment.<sup>57</sup> He writes of the transformation that occurred during this period:

What was developed in the Enlightenment was a modern idea of truth defined by error, a modern idea of knowledge defined by failure, conflict, and risk, but also hope (Bates, 2002, p. 18).

Bates's view contrasts with a definition of error as something simplistic that should be removed or corrected to prevent it from hindering truth and order or impeding progress (Bates, 1996, p. 307). His perspective of error can also be studied in the context of the quest for perfection within print history. It is

---

<sup>57</sup> The historian and writer Barbara Maria Stafford provides a provocative example of Enlightenment thought. During this period, marbled endpapers in a book were thought of as a risk or threat, in that 'aimless pandemonium was incarnated by marbling [...] by their distracting directionlessness, [which] evoked associations of irrational erring' (Stafford, 1991, p. 205).

significant that while the Enlightenment pursued rationalist thought, it utilised error in its search for knowledge. By positing error in relation to truth, Bates reminds us of the subjective nature of both error and truth, and truth's relationship with intention, stating how 'truth remains invisible and must be the object of some kind of quest' (Bates, 1996, p. 314). This is a testimony to the unpredictable relationship between reason and the production of knowledge, which in its aspirations, as one would expect, is itself embedded with error.

One could very well question the authenticity of a quest for knowledge that starts with a known outcome, over the value of focusing on paths that originate with an individual's own experiences or existence. On my part, this is reflected in the deliberate insertion of algorithmic error, and more broadly in the commitment to artistic research in drawing one's attention to the merits of steering away from predetermined outcomes or objectives common to conventions of academic research. Errancy is routed in our sense of being and can emerge as an abstracted digression (allied with wandering). In contrast, an error that is a deviation is perhaps in essence more predictable (allied with reason and cogent thought). The latter could be captured in an error message on a printer alerting to a paper jam. Feeding 30gsm newsprint into a photocopier, for example, is a strategy for impeding accuracy and removing the element of control from a normally orderly system of communication.



Although foreseeable and predictable, this kind of error remains an expressive opportunity and a good analogy for my methodology (see *Enchiridion* and User Guide). The media theorist Mark Nunes encapsulates such opportunities when he explains: 'In its "failure to communicate," error signals a path of escape from the predictable confines of informatic control: an opening, a virtuality, a poiesis' (2011, p. 3). It would be interesting to imagine this misadventure in terms of the relationship in *Reading Enchiridion* between my artistic intentions, The Reader's ambitions for accuracy, and errors that stray back and forth and slip between intention and chance. Navigating the intersection between distraction and The Reader's determination for correctness reveals an interaction that sums up my aim in the project: to uncover how error obstructs and disorders rationality. Intention, I suggest, should not be cast aside as a less errant or creative element in favour of the accidental. Fazi marks how 'the phenomenological tradition in philosophy' is focused 'on the meaningful and rich continuity of an intentional and reflexive relation between a perceiver and a perceived' (Fazi, 2019, p. 6). What is especially interesting about Fazi's phenomenological positioning is the attention paid to intention, as well as the limits of technology and thought which cannot be reduced or simplified. The cohesion of my intentions and The Reader's ambition are likewise emphasised between the logical script and the errant thought.

Returning to Williams's analysis of error (introduced in Chapter 1), which he defines as a 'discrete entity' (1981, p. 152), and in the light of the observation that error is not definite and rather is deserving of intelligent treatment, I would like to stress the point that error can be interpreted differently because, as Williams proposes, it relates to experience and knowledge. Error can be measured in terms of our own encounters with it and understanding of it; we each experience errors differently. That being so, error can traverse between misadventure and deviation, accident and intention.

What is called to question here is error's potential and how it facilitates a straying from contemporary rational thought to permit access to a network of complex relationships between purposeful deviation and wandering through abstracted thought. *Reading Enchiridion* uses the printed instructional script to stimulate irrational and errant behaviour in the human body and in language, and the text serves as a printed imaginary, a script for the future.<sup>58</sup> There is a creative tolerance for wandering and deviation in the project which does not privilege whether something is incorrect, but defines an in-between space that reflects the inherent complexities of error.

---

<sup>58</sup> See Appendices: Hackers & Designers, *Network Imaginaries. Re-imagined Futures* (2021).

### 5.3 Not knowing as artistic enquiry

As mentioned so far, in my practice error signifies a space of unknown potentiality, and the post-digital condition provides a creative framework for exploring and harnessing unseen or unknown opportunities. Since this is the main argument of my research, it is important to examine the critical and creative possibilities of *not knowing* and its reciprocity with error. *Reading Enchiridion*, which is central to this discussion, looks at how exactly error affords an uncertainty and a sense of not knowing. The project sets out to resist knowing through creating an opportunity for error to wander and deviate, embracing unpredictability. The intention here is to explore spaces beyond the safety of being connected to that which is given – the original instruction sets on wikiHow, for example – or a known outcome. The preference is instead to take risks and be open to misadventure and the unknown.

The *unknown*, *not knowing*, and *non-knowing* are terms used interchangeably in this text to imply a space that veers towards the unresolved, undetermined, or unfixed; this is indicative of the fluidity of my distinct interpretation of error.<sup>59</sup>

A deeper engagement with epistemology is not a core focus of this thesis, yet

---

<sup>59</sup> To be *unfixed* or *fluid* is reflective of our contemporary society where we no longer adhere to binary distinctions of gender and social groups, and in the de centralising of societal norms, education, the curriculum and so on.

there is an ingrained inter-connectivity and richness to the relationship between not knowing and error that suggests a lack of knowledge is *a priori* when it comes to error.

As an artistic enquiry and 'condition of thought' (Fisher and Fortnum, 2013, p. 16), not knowing has been creatively theorised and imaginatively explored by Emma Cocker, as previously mentioned, and by Elizabeth Fisher and Rebecca Fortnum in their book *On Not Knowing How Artists Think* (2013). There is a creative lure to crossing the boundaries between what is known and the unknown in aesthetic thinking and physical activity: from not knowing how a text character will appear on the paper when the typewriter key is lightly pressed, to not knowing the direction this sentence will take as it materialises on the screen. For the purpose of this chapter, cognitive modes of error are foregrounded, and *Reading Enchiridion* explores not knowing as a thought experiment. This approach can be characterised as an exercise in 'thinking through doing' (Fisher and Fortnum, 2013, p. 7), and is receptive to the promise of not knowing, which as Cocker claims might 'be the ground from which creativity springs' (2013, p. 126). It is as if a lack of receptivity to the potential of not knowing could be overcome by the insertion of error. Our instincts guard against unknowing and so we need strategies such as error to open up this space.

In the reproduced instruction sets used in *Reading Enchiridion*, error obstructs The Reader, preventing him from accomplishing the assigned task which is to read the instruction sets in an authoritative, assertive, and knowing manner.<sup>60</sup> My motivation in *Reading Enchiridion* is to renounce reason and let meaning wander from literal comprehension to the sphere of the unknown. The use of repetition and liveness in the project function as tools to create errors in the form of misreading, slip-ups, and differences that contribute to a sense of illogicality.<sup>61</sup> Granting agency to repetition itself, The Reader's recital is not fixed, as he produces various mistakes at each attempt, and persists in its unknowing despite The Reader's (failed) attempts for accuracy. Each repetition and fresh start resists knowing. At the same time, on every attempt, the reading retains some of the previous errors that tended towards irrationality, reminiscent of Bates's suggestion that error loses some of its characteristics each time (2002, p. 35) (see 5.2). The Reader's 'thinking through doing' manifests in the form of reading that is performed live, is beyond a linguistic response, and instead is allied with the unforeseen (Cocker, 2016a, p. 106). 'The criticality of a performance could be conceived in relation to the

---

<sup>60</sup> See Project Description 2.

<sup>61</sup> Repetition as method is embedded in my print-based practice. Historically, multiplicity and reproduction are the very foundation of print. Latour writes: 'Repetition is a machine to produce differences with identity' (Latour cited in Schmidgen, 2012).

possibility therein for encountering something new; in the challenge, provocation and even pleasure of the unexpected' (Cocker, 2016a, p. 108). The uncertain modes of liveness and repetition in *Reading Enchiridion* embody my formula for uncovering new understandings of error. Fisher and Fortnum write of the 'creative and transformative potential of not knowing' as:

[T]hat which has too often been devalued within a rationalist Western tradition; however, in re-evaluating that tradition, it is just as important to note the ways in which its supposed rationalism has itself depended on strategic and constitutive ignorance in ways that are anything but creative and that tend to block, rather than promote, social and political transformation (Fisher and Fortnum, 2013, p. 29).

*Reading Enchiridion* is cognisant of a 'transaction with the unknown' (Fortnum, 2009) where error persists and pervades literal comprehension, challenging the dominance of rationalist thought. Throughout the project, error shifts away from an increasingly accurate and known conception of the world. The productive potential in such a shift is apparent if one considers how error creates disorientation in *Reading Enchiridion* between the familiar and the unknown, resonating with the other spatial terms I have introduced like deviation and wandering. The project advocates a species of knowledge that is determined by error, uncertainty, difference, and a confidence to encounter the unknown. This optimism, I argue, posits an appreciation of not knowing as a means of accessing untold knowledge.

Further considering the possibility of an entanglement between error and not knowing, I return to Bates who proposes: 'there exists no map of the new territory to be explored, the errant course of previous adventurers is the only compass guiding the philosopher' (Bates, 1996, p. 314). Bates's analogy of spatio-temporal mapping is useful in visualising the complex terrain that, like the conceptual diagram, is *unknown* and acknowledges the potentiality of former errors. The question remains, however: What of starting afresh each time? Can we reimagine a future that is uninterested in the 'what already is and has been' (Jones, 2013, p. 16)? And what of a practice that seeks otherness in a bid to prioritise the marginal, the edges, and the unseen (Jones, 2013, p. 26)? Or perhaps a practice pursues the unknowable, in the light of what the writer Salomé Voegelin defines as a 'portal' to 'the unthinkable and the unimaginable, which we might have to make use of to solve those problems that we do not have answers for and those that we do not yet know' (Voegelin, 2019, p. 103). The condition of the *unthinkable* can be enticing when one considers how in *Reading Enchiridion* the recital is previously untold and exists in the moment; it is not able to be known. *Reading Enchiridion* displays a post-digital fluidity where distinctions of error become blurred, reinforcing my claim that error is both *yes and no*, drawing on Williams's 1981 *yes-no* argument about error in grammar (analysed in Chapter 1) and Cocker's 2016 book, *The Yes of the No*, which consists of a series of provocations surrounding the

concept of *what if* or *what might be*. The space in *Reading Enchiridion* is beyond a choice of *either/or* dichotomy, and is capable of being composed of multiple folded conditions creating a momentarily connection and a reimagining. The blurring of states in *Reading Enchiridion* possesses a materiality, resonant with the image rather than a conventional language, as it resists all meaning that is concerned with sense and knowing. At certain points, the unintelligible language is not capable of being grasped cognitively. In its inconceivability and nonmeaning, the project becomes an experiment that confronts existing habits of thought – as the artist Hannah Perner-Wilson writes of “‘thinking” as abstract (immaterial) making’ (2019, p. 111). The words in *Reading Enchiridion* speak their own language, in a voice that is not our own, or previously known. Voegelin describes ‘thinking [as] a project of intelligible words’ (2019, p. 100) and claims how artistic practice is itself something unthinkable:

Not because it might not use words but because the words it uses almost immediately cease to comply with semantic meaning and instead drag communication into the opacity of the material: its sounds, its breath, its graphic image, rather than what it meant to say (Voegelin, 2019, p. 100).

*Reading Enchiridion* expresses a tendency towards philosophical uncertainty as a consequence of cognitive erring. Voegelin’s *unthinkability* is juxtaposed with logical or systematic thought. This is in contrast, for example, to the literal



printed errors analysed in *Enchiridion* (in Chapter 4). However, both projects connect with the potentiality of not knowing, in the form of representational printed noise or abstracted wandering thoughts. The Reader's errors in *Reading Enchiridion* resist knowing, from literal comprehension to non-knowing.

To clarify my findings in terms of misadventure and deviation relations, I would like to emphasise the fact that the digital world is rational, comprised of drop-down menus and linear and chronological social media threads where everything is intentionally rationalised and orderly. That is to say, we live in a controlling digital culture, and the post-digital strategy is what defines my aimless wandering and rejection of clinical rationality and certainty. There is a complexity and vastness to our culture – do we privilege the randomness of being human or data and spreadsheets? Whilst the latter are tools that augment and extend us, like the axe, the loom, and the printing press, my text is framed around embracing human error and the uncertainty of being human. I am a human wanderer in a rationalised space. My aim is to show how in an overly simplistic and sanitised culture, error provides creative and uncertain paths which can disrupt data, information, and systems. The agency of error and its ability to destabilise and break free from knowing is further discussed in Chapter 6.

## *(Un)learning*

Deleuze's definition of error as a form of *wandering* (discussed in 5.1) is characteristic of *unknowing*. Both modes of thinking inform my understanding of error as meandering between meanings or, correspondingly, between knowing and not knowing. In *Reading Enchiridion*, error disrupts the logic of wikiHow instruction sets created to help an individual to learn how to do something. The intention in *Reading Enchiridion* therefore becomes not one of *learning*, but an exercise in *unlearning*. Whilst knowledge (like error) may be imperfect, reason and rational thought can reveal – and subsequently correct – errors. If we accept, as outlined by Bates earlier in the chapter, that our intention should not be to correct mistakes, and rather that it should be to learn, or as I posit here to *unlearn* from previous experiences and let error and not knowing prevail, then we can take pleasure in the uncertain and tangled path error forges between knowing and unknowing. On the quest to find knowledge, Bates writes:

The problem of finding the straight ('true') path of knowledge [is] particularly complicated. Error was not the exception to a well-traveled path, an accidental straying from a properly marked, sufficiently lit road. With every step we took, the 'path' was slightly crooked, and it was not easy at this point to map out the promising directions (Bates, 1996, p. 312).

Similarly, my understanding of the artistic process is that by staying open to the uncertainty of misadventure the focus shifts from seeking known directions.

With this point in mind, in *Reading Enchiridion* the script no longer functions as a learning tool where one follows a logical sequence, rather it operates as a mechanism to unlearn this logic. A key discovery of the project is that being receptive to unlearning provokes one to reconsider methods and systems of learning, sharing and distributing information.<sup>62</sup> As such, in *Reading Enchiridion* the recital of the reproduced how-to guides constructs an *unlearning space* capable of challenging existing habits of thought, as well as systems for learning and acquiring knowledge.<sup>63</sup>

Unlearning is a creative tactic in that it allows us to open ourselves up to the potential of not knowing. Yet, historically, unlearning has been a problematic term within artistic research (see Chapter 2) – and it is perhaps even more problematic when one is on a quest to learn and contribute new knowledge as part of doctorate studies.<sup>64</sup> The theorist Irit Rogoff calls for a revision of processes of unlearning, inside and outside the academy, that will pave the

---

<sup>62</sup> See *The un-Learning Zone* in the Appendix.

<sup>63</sup> HKWs long-term project *(Un-)Learning Place* (Scherer, 2019) explores strategies for unlearning the ordering systems archives, museums, libraries, and digital networks use for classification, asking: 'What would spaces of learning and unlearning look like in a world permeated by institutional infrastructures of dominance and cultural supremacy?' (Scherer, 2019).

<sup>64</sup> There is an institutional pressure on, and conflict in, practice-as-research within institutional infrastructures surrounding the ideas of knowledge creation and 'non knowledge' that does not fit neatly with the dominance of cultural research supremacy (Scherer, 2019).

way to new and unexpected kinds of knowledge (2008). The unlearning space referred to in my project is likewise sympathetic to a conceptual *letting go* for the sake of uncovering new forms of knowledge not accessible through exploring known paths. My project provokes unlearning through disrupting texts intended to promote mass produced reason. It interrupts/disorders the rationalist thought proposed on wikiHow, which advocates a neoliberal notion of success.<sup>65</sup> As a mode of resistance, unlearning disrupts the wikiHow structure and challenges the notion that acquiring knowledge equates to bettering ourselves and the world in which we live.

This post-digital response acknowledges unlearning as a means to question modes of online knowledge production and sharing, and is a call to considering the subjectivity of information available in online learning spaces.

While the original wikiHow instructions are bound to the taxonomy of the known, *Reading Enchiridion* is crucially driven by the reality of a future knowledge as yet unthinkable (Voegelin, 2019, p. 105). Despite the text's

---

<sup>65</sup> The language of the original wikiHow instructions reflects a neoliberal attitude, which might be perceived as promoting a toxic notion of success. Furthermore, with the origin of wikiHow as a collective endeavour and a space to share knowledge, it does not reflect *us* as a community in the language used; rather, there is an emphasis on *I will* or *you should* telling you what to do. My question is: *Can you must...* become *we can...* which is more reflective of the community it aspires to represent? This is an issue that contributes further to the complexities of online culture and spaces.

origin as a set of literal instructions, the context of my project is not about learning, or instruction, or explication (Cocker, 2016a, p. 106); rather, it embraces that which is outside of us. Our sense of *becoming* lies in staying open to encounters with error 'as the condition of possible transformation' (Jones, 2013, p. 18). The spoken words which energetically collide are opposed to the rhetoric of success implied on wikiHow. It is as though a computer is reading code, and not a performer reading in real-time. One could ask whether the erring language, or The Reader's gestures as he stumbles whilst at the same time asserting an air of knowing and assurance, or the aesthetic situation itself, can initiate new meaning freed from the ambitions of rational thought (see User Guide) or the pervasive influence of digital logic (discussed in 4.3). Might The Reader's errors and slip-ups challenge the way we read and navigate online learning spaces and confront notions of success? In response to these questions, error in *Reading Enchiridion* provokes a re-evaluation of truths and falsehoods, suggesting alternative means of reading irrationality, or negotiating reason.

### *Diagrammatic thinking fosters uncertainty*

Lastly, there are noteworthy parallels between *Reading Enchiridion* and my diagrammatic practice. The conditions of non-knowing and unlearning present in *Reading Enchiridion* are shared with diagrammatic thinking, since the

diagram, like abstract thought, is expansive.<sup>66</sup> In *Reading Enchiridion*, there is a sense of thoughts expanding and touching upon that which is unthinkable or unknowable, and in doing so broadening an understanding of error that evades literal interpretation.

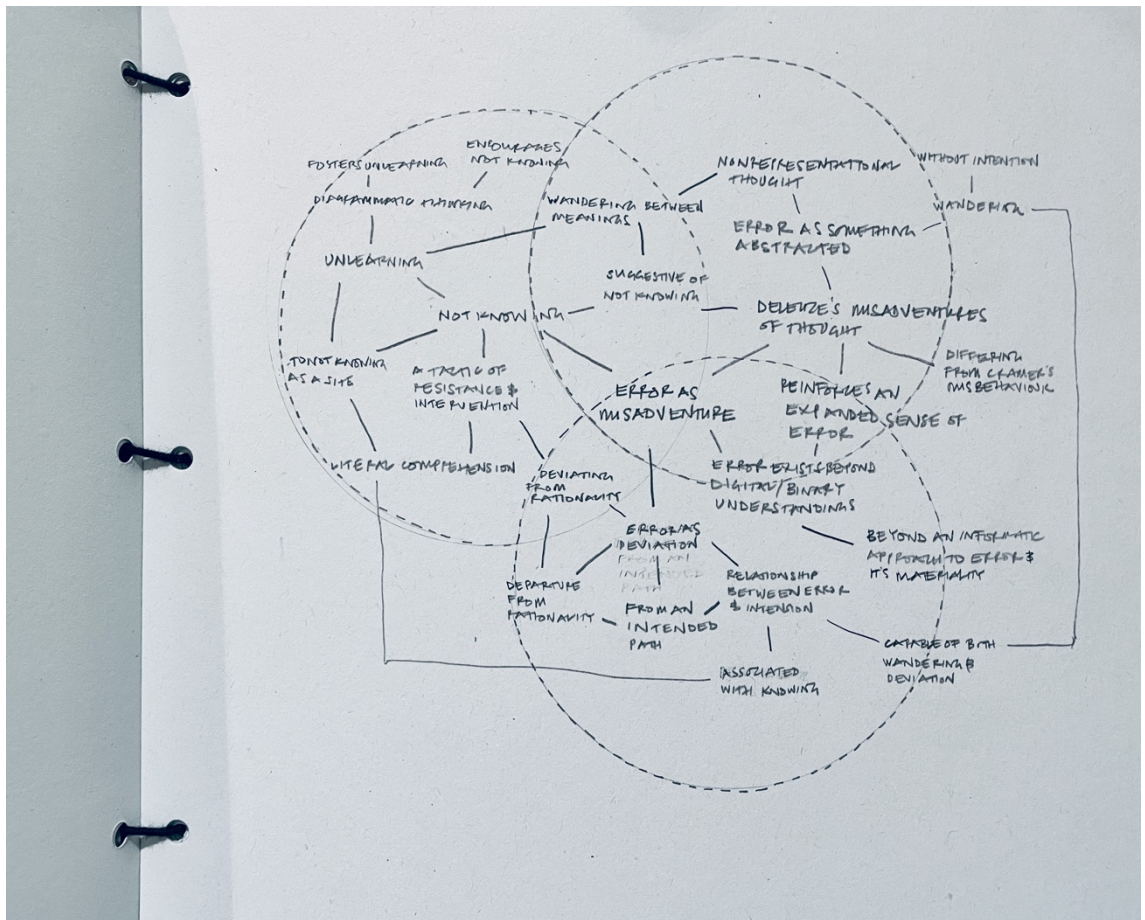

Figure 56: Error as Misadventure (Rosser, 2021). A Venn diagram from my sketchbook.

<sup>66</sup> See Meta-Diagramming project in the Appendices.

The objective of the project and the resulting discussion is to reveal how, like the structure of the Venn diagram (Fig. 56), error is at the centre of this research, surrounded by doubt, uncertainty, and persistence. In line with the ambivalence of post-digital thinking (discussed in Chapter 4), the project creates a nuanced experience of error as something that is noncategorizable. *Reading Enchiridion* upgrades error to a space where not knowing and unlearning pave the way towards renewal. By intentionally ceding to the authority of error, The Reader engages in a relationship with unknown potentiality – only accessible through error.

## Summary of Part Two

The discussion surrounding my practice in Part Two has endeavoured to expose the material, technical, and social aspects of error and glitch culture (as surveyed in Part One). Chapter 4 uncovers how the post-digital alludes to a new sense of materiality, though not in a fleshy, tactile, or post-human sense (Mitchell, 2004, p. 221, cited in Charlton, 2014, p. 10). Rather, as has been established across Part Two, there is a call for a rethink of the materiality of error and print technologies. The analysis of non-knowing and the potentiality of error under post-digital conditions is not limited to Chapter 5, and is prioritised across both chapters.

This sets up the discussion on agency and relations that will take place in Part Three, with reference to the question: '[H]ow is the elusive notion of the nonhuman to be situated in relation to media in the post-digital age?' (Bishop *et al.*, 2016, p. 15), in hope of prompting a 'post-anthropocentric' response (2016, p. 15). If we can no longer understand things through a human-centred ontology, then who, or what, is responsible to decide what can or cannot be considered to be an error?



## PART THREE

Humans and machines encounter each other in 'material structures' (Bishop et al., 2016, p. 2). These material structures such as printed matter, online and offline systems, and software are inseparable in my projects (see User Guide). These 'messy ecologies of information, [of] the human and the nonhuman' (2016, p. 19) provide a useful context for the discussion in Part Three which problematises human and machine activity, while examining the networks occurring in my projects between methods of error, printed matter, and technology.

In Chapter 1, I mentioned Negroponete's perspective on the materiality of the digital and how he establishes a constructive argument concerning the agency of information. The claim was that in the analogue era, categorisation was more straightforward and therefore things were more easily distinguishable as individual and influential matter (1995, p. 54).<sup>67</sup> In contrast, he suggests that in the digital era these differences blur and everything is reduced to bits (1995, p. 54). Although somewhat convincing, this is an oversimplification.<sup>68</sup> Taking this

---

<sup>67</sup> Negroponete uses the example of pointing to different parts of the electromagnetic spectrum as with TV, radio, or cellular telephony (1995, p. 3).

<sup>68</sup> For example, digital devices, as discussed in previous chapters, are 'analog-to-digital-to-analog converters' (Cramer, 2014, p. 14). Transitioning between the analogue continuous

into account, and considering the post-digital debate in Part Two, it is clear that the boundaries between analogue and digital systems are far more entangled. Subsequently, an emphasis is placed on matter and force which will be explored in Chapter 6 with reference to the project *[mis]Feeds*, and in Chapter 7 in association with the project *[mis]Folds*.

As an artist, I actively seek out errant behaviours and printed *mistakes*, *misprints*, and *misfeeds*, and refrain from actions which foreclose error's ability to act. Chapter 6 analyses how my renunciation of certain artistic powers – which is also troublesome for me at times – creates space for the existence of a diversity of other agents of error in my projects. Across this third part of the thesis, I adopt the term *entanglement* in my study of error's agency to describe the innate relation of error to other entities, and the term *network* to reflect the systematicity of error in print-based processes and technological apparatus. Both terms are used intermittently to support my discussion on the complexities of what I have called error's cross-talk in my practice – a relational condition that spans digital systems, paper, and ink.

---

continuity of, for instance, sound, to a system of binary computational information processing, and back into analogue sound waves (Cramer, 2014, p. 17).

Chapter 7 advances the discussion of agency by investigating the relational network of humans and printed or digital information in my project *[mis]Folding* (see Project Description 4) and draws upon actor–network theory and new materialism. Although actor–network theory preceded new materialism historically, here the discussion traverses between these schools of thought, calling on new materialism for its focus on the vibrancy of error, and actor–network theory for the attention it pays to the interconnectivity of nonhumans things. Consequently, in Part Three the digital is characterised by broader networked agencies that include nonhuman things, rather than binary relations. This is not to refute the fundamental existence of 1s and 0s in computation, but rather to provide a more elaborate view of digital materiality.

## Chapter 6: Errors-in-Action

Post-digital error is not a dichotomy in my practice; it is many things, such as the action and flows of misprinted paper, or data and information loss in a computational system. In this chapter, I explore, alongside my project *[mis]Feeds*, how this aspect of the digital is important when thinking about error's exhibition of agency and its responses to post-digital conditions. I draw from the latter statement and how the post-digital supports debates for nonhuman matter by placing focus on all aspects of technology in the first section of the chapter. This opens up the conversation in the following section on the sites of activity and cross-talk between technologies, humans, and error in artistic practice. The earlier elaboration on the digital in Chapter 4 prepared the bedrock for the argument in the third section, when I think about how energetic matter is beyond common ideas of materiality, which in terms of error is unruly, and this is discussed in the fourth section. Overall, the influence of nonhuman matter is explored in this chapter through both new materialism and actor-network theory, and in parallel with my project *[mis]Feeds* (see Project Description 3).

The chapter thus articulates the way in which errors, print technologies, and the paper on which things are printed, begin to develop their own sense of agency

in the project *[mis]Feeds*. As should be apparent by now, the importance of error's ability to impact practice is a core argument of this thesis. It influences me as an artist, and additionally it affects the paper and print technologies which are fundamental components of my projects, as in the example of *[mis]Feeds*. Indeed, where does the agency of the artist end, and the agency of the artwork begin?

### **6.1 The post-digital is no longer the domain of the human**

Pursuing a human-centred ontology is no longer perceived to be an adequate means to discuss the world. Such an approach occludes nonhuman matter – such as ink, paper, or errant thought – and ignores the larger systems involved – technological, social, biological, chemical or other (Parnow and Heinicker, 2020). Despite the ability of human subjects to provide large-scale insight, attention to the nonhuman must begin on a detailed level. Here, I outline a post-human ontological approach where minutiae are important. In this way, printed errors have the ability to act and influence artistic practice, perhaps even to be a constitutive element of artistic practice.

As introduced in 1.3, actor–network theory is a social, theoretical, and methodological approach that aims to understand how things exist in

constantly shifting networks and relationships under post-digital conditions. Whilst relationality is the focus of my discussion in Chapter 7, here I draw on Latour's thinking on *material agency* and analyse his emphasis on systems and nonhumans to reinforce my argument in favour of error's ability to cause effect. Latour extends the term *actor* beyond the individual human to include the non-individual and nonhuman (Latour, 1996, p. 2). He grants objects agency and ties these agencies in with the social fabric. This connects agency to the collective building of meaning, rather than assigning agency to the individual, which would counter the agency of things (1996, p. 6). Furthermore, his unrelenting attack on categories denies distinctions of, for instance, inside/outside, before/after, knowledge/power, materiality/sociality, and activity/passivity (1996, p. 5). A similar concern for a wider set of fluid agencies has been outlined in earlier chapters.

Of further significance to this discussion, Hayles writes of a need to rethink how we articulate human and mechanical or computational agencies, in a bid to 'realign human and technical cognitions' (2017, p. 14). Hayles's argument resonates with post-digital thinking and practices, where our fractured relationship with technology is dissolving, as is the distinction between human, machine, and system – as exemplified by the Covid-19 pandemic and climate emergency. With this in mind, we cannot continue to prioritise our own

interests, or think of ourselves as dominant beings over all other things in our (lively) world. This awareness has never been more urgent than with the threat of the current pandemic which, as Latour suggests, stresses our modes of connectivity and blurs the distinctions between private and public, human and nonhuman (2020). The tension between these related, yet competing, tendencies is redolent of my argument for the messiness and polarity of our relationship with technology that is multi-scalar. Indeed, post-digital print operates at multiple scales; in the case of *[mis]Feeds*, with printers and entanglements of systems, algorithms, and ideas of post digitality (Fig. 57).

The category of post-digital enables us to redirect our attention from discontent (or resistance) to the digital in order to prioritise methods of discussing and better understanding human and nonhuman agencies. In such entanglements, we are all parts of a larger whole, where individual agencies are not allied with humanistic characteristics such as rationality or intellect, and by contrast favour intervention and instrumentality. As the feminist theorist Elizabeth Grosz suggests, agency 'is not tied to the emergence of reason, to the capacity for reflection, or to some kind of integrant quality of the human' (2007, p. 132–85, cited in Shaviro, 2014, p. 11). This reinforces the (posthuman) position that humanity is not the measure of all things. The preference is

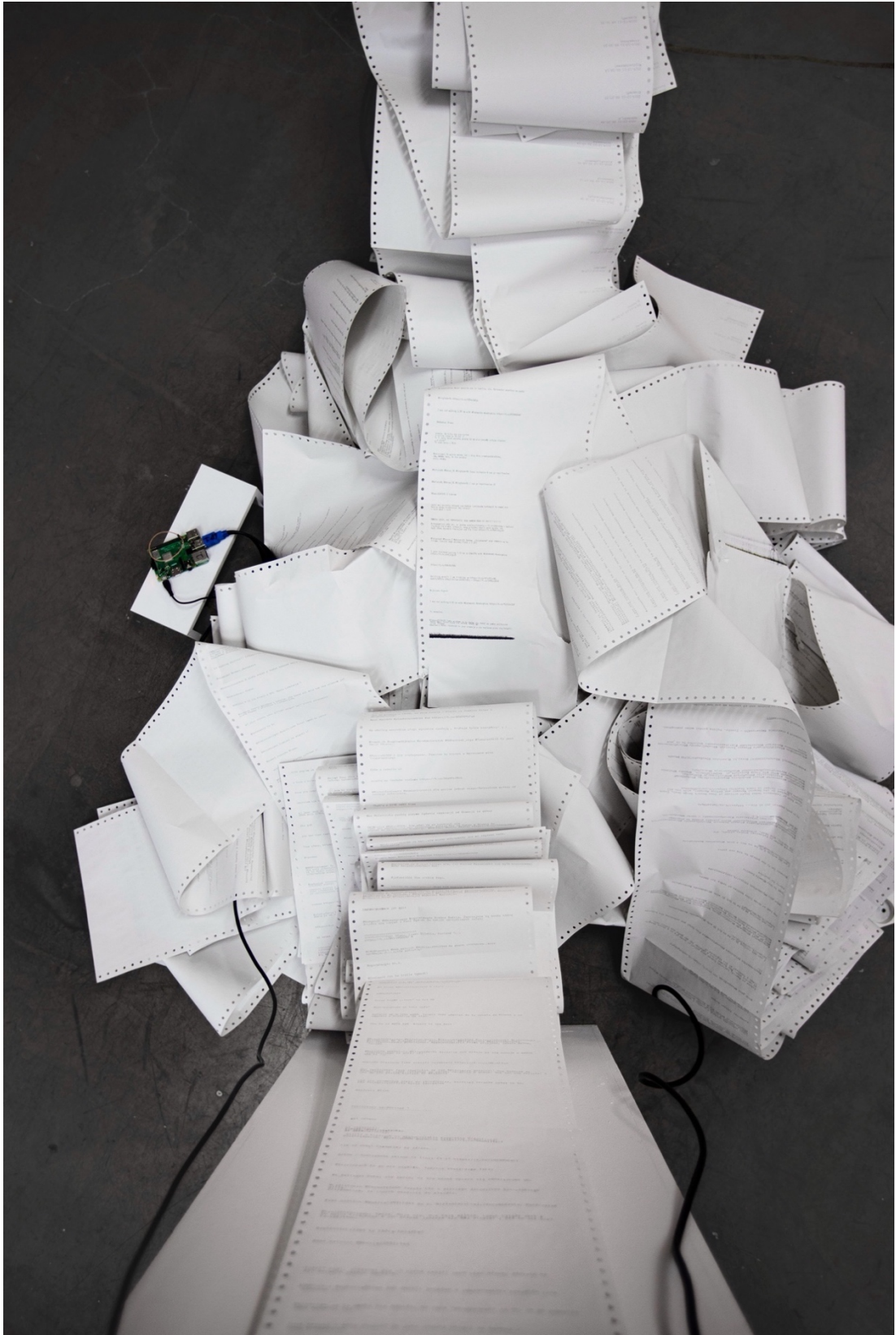

Figure 57: *[mis]Feeds #1* (Rosser, 2019). Entangled printed paper feed, printers, and Arduino. Image: courtesy of Marcin Wysocki.



instead for a mediation between people and nonhuman conditions not related to logic or intelligence, and this applies to my relationship with printed matter in *[mis]Feeds*. In doing so, the project reflects post-digital and posthuman attitudes where encounters and meanings are shaped by humans and nonhuman entities.

The anthropologist Alfred Gell ascribes agency to things (and humans) that instigate causality. He writes, 'an agent is the source, the origin, of causal events, independently of the state of the physical universe' (Gell, 1998, p. 16). Such a definition attributes agency to things beyond the material world, such as a tweet, a speech, or a printer's activity. It pertains to post-digital thinking and acknowledges more immediate and small-scale effects; in regard to my project, errors can be seen to influence the things they are entangled with. The materiality of error is lively, and the project's dynamic cross-talk between printers, technology, and error is comprised of multi-scalar actions between various entities. Consequently, errors occur in spatial as well as temporal conditions.

This approach to the agency of print error is extended to include a focus on the live 'democracy' of things, to adopt Harman's words (adapting Harman's phrase, 2009, p. 103, cited in Shaviro, 2014, p. 11), which includes nonhuman

errant encounters in *[mis]Feeds*, manifest in the printed material as a form of fibrous interface between paper, printer, and computer. Including nonhuman worlds in this project has allowed me to connect the immateriality of human idea with the materiality of print technologies. The project *[mis]Feeds* is concerned with human and nonhuman space-times, where an inclusive experience of material and immaterial things is prioritised. Can my artistic practice then be envisaged – not just in terms of reflecting human agency and subjectivity – as a means of gaining access to nonhuman knowledge? Although errors in print tend to be understood as a matter of objective fact (as debated in Chapter 4), they are actually open to subjective interpretation due to people’s experiences or understanding of print. They are related to taste, expectation, subject knowledge, and so forth. My project explores an aesthetic that prioritises material agency, and which is less interested in human subjectivity, reflection, or judgement. As one might observe in *[mis]Feeds*, errors are definitive things that emerge as dynamic relational entities.

## **6.2 The liveliness of error**

To substantiate the arguments that have been introduced thus far, I now call upon the field of new materialism, which challenges the anthropocentrism that dominates Western rationalism. New materialist thinkers seek to flesh out novel

ways of perceiving the living world through determining all things, human and nonhuman, as equal. In Chapter 1, I briefly set out how Bennett claims that nonhumans exhibit a positive force, or 'vital materialism' (2010a, p.13), where all matter is entangled and lively. In this respect, new materialist ideas provide a persuasive foundation for an exploration in this chapter of the creative *liveliness* of errors in my practice, such that neither humans nor printed matter are considered outside observers.

Bennett's definition of agency is 'a materiality that is itself vibrant or active' (2010b, p. 49). Her perspective and account of *thing-power* (to be examined later) defines nonhuman things as not only energetic but interconnected, with the capability of engendering new knowledge. Bennett's concept of entangled agencies supports my proposition in *[mis]Feeds* and this chapter that error is energetic and acknowledges wider agencies, and that humans and nonhumans are co-inhabitants under ecological and societal factors (Bennett, 2010a; Latour, 2012).

Notably, new materialism calls attention to the vitality of both human and nonhuman matter. The *turn to matter* originates from a 'collective discontent with the linguistic turn and social constructionism to adequately address material realities for humans and nonhumans alike' (Sanzo, 2018). This

approach shares an agenda with posthumanism in their mutual endeavour to relocate the human among the nonhuman, and to prioritise 'more than human' perspectives. My project *[mis]Feeds* plays a small part in dissolving human centred perspectives by electing to focus on the way that nonhuman matter (specifically error) exhibits its own subjectivities, removed from anthropocentric ideals. Bennett writes of how vital materialism is resistant to anthropocentrism in philosophical history, which is distinct from historical ideas of materialism (Bennett, 2010a, pp. xv–xvi). Her nonhuman vibrant materiality opposes the application of human agencies of language and thought to nonhuman matter (2010a, p. xvi). Whether a physical object such as a sheet of paper, or a dialogic situation such as a conversation on social media, or a communication between Twitter, printer, and paper – all matter can be understood to possess an innate energy. The theorist Susan Yi Sencindiver discusses how:

New materialism foregrounds novel accounts of its agentic thrust, processual nature, formative impetus, and self-organizing capacities, whereby matter as an active force is not only sculpted by, but also co-productive in conditioning and enabling social worlds and expression, human life and experience. (Sencindiver, 2017).

This is significant when it comes to *[mis]Feeds*, as it highlights how error's co-creative force affects things beyond material experiences in the printmaking process. Error is capable of co-producing and stimulating new situations within

(and external to) the ecology of the project, including the cultural, political, and social, by perpetually shifting, re-organising, evolving, and reforming.

Bennett's *Vibrant Matter* (2010a) expands discussions of material agencies through her argument for the vitality of human and nonhuman assemblages. She calls the agential thrust of nonhuman matter such as ideas, thoughts, and experiences a 'thing-power', which I perceive as epitomising the capability of error to distribute in my practice a lively form of agency with unlimited scope. Thing-power points to a form of efficacy that applies to all matter, and Bennett describes this as the creative potential of agency (2010a, p. 31). It is useful to define how efficacy extends the notion of agency. Efficacy refers to the scope of agency, whereas agency refers to the actual capacity for change (Bandura and Adams, 1977, p. 288). Efficacy emphasises the ability of something to produce a desired effect, in addition to centring on actual or existing activity. If everything has potential, but on different scales, efficacy can be understood as the scale of said potential. Or, rather than a scale, it could be argued that efficacy *is* the scale of agency. For instance, we could say that a printer has less efficacy than Covid, but maintain that they both have agency. Do all my printers have the same agency (Fig. 58)?

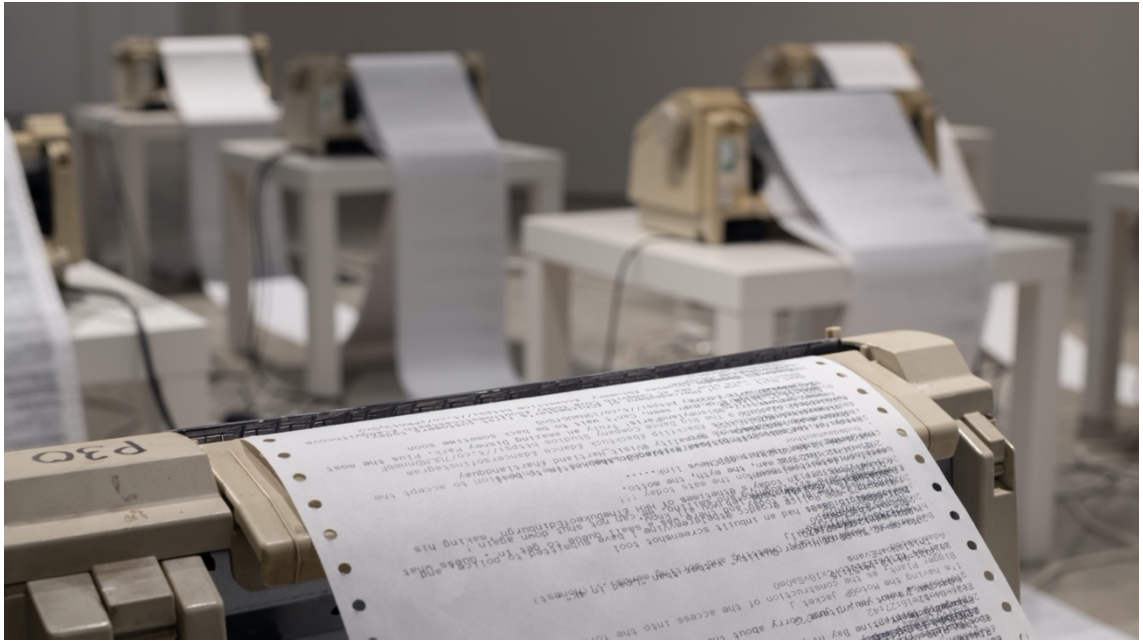

Figure 58: *[mis]Feeds* #3 (Rosser, 2021). Installation of printers, each programmed to carry out a specific task. Image: courtesy of Helge Mruck.

Thing-power marks a departure from the autonomy of human beings, who are 'cloaked in the alibi of [humanistic] language' (Harman, 2011b, p. 125) signifying a shift towards a wide-ranging interpretation of language and systems of communication. In *[mis]Feeds* this can be perceived as the collection of previously discarded dot matrix printers which hold a latent ability to act (2010a, p. viii). Although the project and this chapter stress the force of error itself, it is important to recognise that this materiality exists alongside and inside humans: as Bennett claims, 'human power is itself a kind of thing-power'

(2010a, p. 10).<sup>69</sup> Bennett describes efficacy in terms of agencies generally and compellingly she pursues expansive understandings, reminding me of my own wide-ranging approach to the concept and practice of printmaking. This helps me to prove my argument for the artistic potentiality of error and its emergent vibrancy, to use Bennett's terms (2010a, p. xiii). Error exerts its creative influence on objects and things, on reality and concepts.

Errors are impacted by internal and external conditions. Error's dialogue with paper, printer, and internet, changes rhythm while mis-folding and re-folding, twisting and contorting into something new, something otherwise. Bennett writes: '[Errors] exceed their status as objects and [...] manifest traces of independence of aliveness, constituting the outside of our own experience' (2010a, p. vxi). Errors in *[mis]Feeds* move between different bodies, forms, and technologies to create dynamic feedback loops between paper, print, subject, and system.<sup>70</sup> The performativity of these lively agential things is what I refer to

---

<sup>69</sup> Bennett writes how:

'at one level this claim is uncontroversial: it is easy to acknowledge that humans are composed of various material parts (the mineralogy of our bones, or the metal of our blood, or the electricity of our neurons). But it is more challenging to conceive of these materials as lively and self-organizing, rather than as passive or mechanical means under the direction of something nonmaterial, that is active soul or mind' (2010a, p. 10).

<sup>70</sup> Deleuze and Guattari describe the body as a mesh of organic or inorganic matter, consisting of flows of materials including living things, rocks and flows of language and information. This expanded underlying structure of the virtual or non-human body is what Deleuze refers to as the 'body without organs [BwO]' (Deleuze and Guattari, 1987, p. 149).

as the cross-talk, which does not pertain to the individual but, as Fig. 59 illustrates, a material dynamism that captures the communication between things.

On a material and structural level, the internal agencies of cross-talk in *[mis]Feeds* are prompted into action by a system of instructions, in the form of a series of simple algorithms written in PHP (see User Guide).<sup>71</sup> Using coded forms of instructions is specific to this project and somewhat at odds with the variable nature of the agencies that unfold. Importantly, PHP is not anthropocentric; rather it is common to both humans and computers: a lingua franca.<sup>72</sup> Whilst algorithms are often associated with solving a problem – as witnessed in data processing or performing calculations – in the project I use algorithms as an attempt to connect the spirited conditions of the project, including that of error, in real-time.

As outlined earlier, Bennett's perspective on the liveliness of matter within human and nonhuman assemblages influences my own approach, where

---

<sup>71</sup> The code was written using PHP and performed by Raspberry Pis, which is output to the printers. PHP is a scripting language used for web development and originally created by Danish-Canadian programmer Rasmus Lerdorf in 1993, and released in 1995.

<sup>72</sup> A language used to make communication possible between those not sharing a common language.





Figure 59: *[mis]Feeds #1* (Rosser, 2019). The printers' fraught activity interrupts the space. Image: courtesy of Barbara Kubska.

printing and drawing real-time data from Twitter can produce a sense of making – I call this *errors-in-action*. This is a rejection of inertia, or of matter that does not participate in the moment (to be discussed in 7.4). In its vibrancy, the snagged paper feed generates a folded, fractured conversation between the printers, paper feed, and social media. The inherent liveliness and erratic nature of errant printed matter, thus, produces uncertainty and pervades creative potentiality. This is explored in the project's multiple variants and developed in parallel with the written thesis – and its drafts. Each version of *[mis]Feeds* uncovers something new: #1 visualises the network; #2 explores

human and nonhuman voices; and #3 exposes a machine assemblage as a 'global feedback loop' (Wark, 2013).

According to philosopher Anselm Jappe, 'technology levels a more telling critique of everyday life, [and] you can just assume that our data is being collected about our lives for future possible use' (cited in Wark, 2013). Jappe's argument helps to enrich my articulation of the errant printed object as exceeding its status as a fixed or stable entity to function as a delimited efficacy, rather than reductive ideas surrounding a simple misprint without wider social or cultural implications. For example, due to misinformation in the assemblage of human and nonhuman experiences, the text is overprinted and extends beyond the paper's edge. The misinterpretation enacts limitations of the network and when it fails, it can be seen as a metaphorical way of teasing out the idea of error in a social context, where it is reflective of wider failures – as, for instance, exposing the lack of *social* in *social media* (Fig. 60).

In the light of the concept of liveliness, I suggest that printed objects do not simply reflect or carry meaning. By addressing liveliness in this way, my project applies post-digital concerns to issues that are more than human. My expanded interpretation of printmaking – as an intervention that extends



Figure 60: Visitors to the exhibition *Sex, Suicide, Socialism, Spirit and Stereotypes* at Kronika Centre for Contemporary Art use social media to send a tweet to the printers as part of *[mis]Feeds #1* (Rosser, 2019).

beyond the edges of the print apparatus or paper surface or inanimate object – applies agential thrust to printed matter through its entanglements with error.

Printed objects are invested with a meaning that changes through their associations and usage. The printer's stuttering, nonhuman modality is embodied within the ethics of shared information, privacy, and the interconnection of people and technology that concentrate post-digital issues around, as mentioned above, more-than-human concerns. Can the collection

of re-purposed office printers shown in Fig. 61 of *[mis]Feeds* – incidentally, salvaged from a factory after a company printing *upgrade* – in turn be use for an exploration of the limitations of networks?<sup>73</sup>



Figure 61: *[mis]Feeds #3* (Rosser, 2021). Fifteen printers connected by paper and Raspberry Pis. Image: courtesy of Helge Mruck.

---

<sup>73</sup> This reminds me of Ludovico's assertion that paper is the universal medium (2012, p. 9), and additionally the feelings of anxiety caused by information overload. The artists Jonas Parnow and Paul Heinicker maintain that 'digitality promised us *immaterialness, equality* and *disembodiment*. It never came to be' (Parnow and Heinicker, 2020). This encourages a rethinking of the validity of printed information and its potential effect in an increasingly ambiguous digitised and impalpable world.

### 6.3 The (im)materiality of error

In addition to Bennett, I draw upon the work of the feminist theorist Karen Barad to describe the materiality of the agencies at play in *[mis]Feeds*. Barad's concept of 'agential realism' is useful in clarifying how matter and meaning – thoughts, objects, experience, actions – are unbounded and meet as material things in very literal ways (Barad, 1996, p. 166).<sup>74</sup> Barad is mainly concerned with the relationship between language and matter, and how materiality has been turned into a *matter* of language. She interrogates human-centred ontologies, posing questions such as: 'why are language and culture granted their own agency and historicity while matter is figured as passive and immutable[?]' (Barad, 2003, p. 801). Thus she highlights a historical lack of recognition for the influence of inert matter, such as can be applied to a misprint in my project, and attitudes which favour the potential of discursive (human) acts as having more impact on culture and society.<sup>75</sup> This seems reminiscent of the almost imagistic replacement of language in *Enchiridion* (see

---

<sup>74</sup> Barad draws on the work of the Danish physicist Niels Bohr, who was also reluctant to see the fields of philosophy and physics as distinctive and was uninterested in creating borders between them. Barad's thinking mirrors Bohr's unwillingness to conform to a culture of boundaries, and notably he argues that this approach can be extended to the humanities (1996, p. 166).

<sup>75</sup> Marshall McLuhan's *The Medium is the Massage* (1964) is a case in point. As mentioned previously, the typesetter accidentally typed *massage* rather than *message*, and the typo conveniently alluded to the mass-age of information communication (McLuhan, 2011).

User Guide), or in *[mis]Feeds* of the sway of language as a material, physical, printed script from Twitter which reveals an assemblage of voices.

For new materialists, 'materialization and its entangled entailment with discursive practices is pursued, whether these pertain to corporeal life or material phenomena' (Sencindiver, 2017). In *[mis]Feeds*, this is extended to the materiality of error, print processes, and technologies. The discursive elements co-exist between human voices (such as those on social media and my own voice as an artist) and nonhuman expression (of the viscous ink, paper fibres, or the cross-talk of information moving between printers). Importantly, the machines are co-performers in the project, communicating through diverse languages, voices, and agencies, while including error as an active participant in the ecology of information.

Barad's argument on how *matter comes to matter* sits well alongside my research (2003) as it enhances the earlier discussion in 6.1; for instance, when exploring how smaller things such as a text that prints over the paper's edge can highlight the impact of nonhuman matter more broadly. This perspective further emphasises how small-scale matters make can make large-scale differences. The media artist Stephen Cornford provides insight on ideas of scale when looking closely at machines. During an interview with the artist

Andrew Prior (2015), Cornford invokes Negroponte's reference to the 'DNA of information' (1995, p. 11) as something that is active and influential, explaining how all machines – or printers from the same manufacturer, for example – share the same DNA. Returning to the efficacy of the printers, and looking at the 'collective' (Latour, 2005, p. 247) of reassembled printers, it can indeed be argued that they behave in different ways.<sup>76</sup> 'When given a voice, machines do not speak any of our languages ... the machine's voice tells us its own construction' (Cornford, cited in Prior, 2015, p. 325). Cornford goes on to explain how 'he has personally learnt a lot from listening to machines' (2015, p. 325). Through close listening, I can confirm that the whirring and stuttering printers do not speak the same language as we do, but rather use their own structure and composition in order to communicate. Cornford's elaboration on the subtleties of machines and why they matter aptly resonates with my clattering printers. He reasons that

plastic is surprisingly resonant, and adds a warm tone to the sound of a speaker mounted in it; that all machines are different, even those from the same production line and that to uncover these individualities you sometimes have to push the machine a long way beyond its intended function; that (perhaps above all)

---

<sup>76</sup> Latour writes of his specific use of the term *collective*: 'this tracking may end up in a shared definition of a common world, what I have called a collective; but if there are no procedures to render it common, it may fail to be assembled; and, lastly, sociology is best defined as the discipline where participants explicitly engage in the reassembling of the collective' (Latour, 2005, p. 246).

the potential of a machine is in no way contained within its design (Cornford, quoted in Prior, 2015, p. 325).

This line of thought has encouraged me to pause and consider the minutiae of printed matter in *[mis]Feeds*. Observing the printer's activity, which spans moments without movement or sound and moments of fraught activity has often revealed overlooked errors: such as an over-threaded printer head screw; heavy pigment particles covering the printer's inner mechanism; the creation of uneven and often illegible printed text by the translucent strip that runs along the centre of the worn printer ribbon (Fig. 62); or the subtle misaligning of the individual punched paper holes on the continuous feed paper; and where each hole misaligns with the tractor feed a little more at each pass, until it *misfeeds*.

The printers are engaged in internal exchanges with the paper as the information overprints, or prints beyond the perforated boundaries of the paper, moving information around the page through actions outside of the bounds of objectivity or prior knowledge. The chaotic arrangement of information which emerges on the paper surface appears at first glance to be removed from the somewhat orderly and knowable structure of Twitter, from which the dialogue originates. Although pages on Twitter are dynamically created from a database – as is much of the internet, as an orderly, dynamic



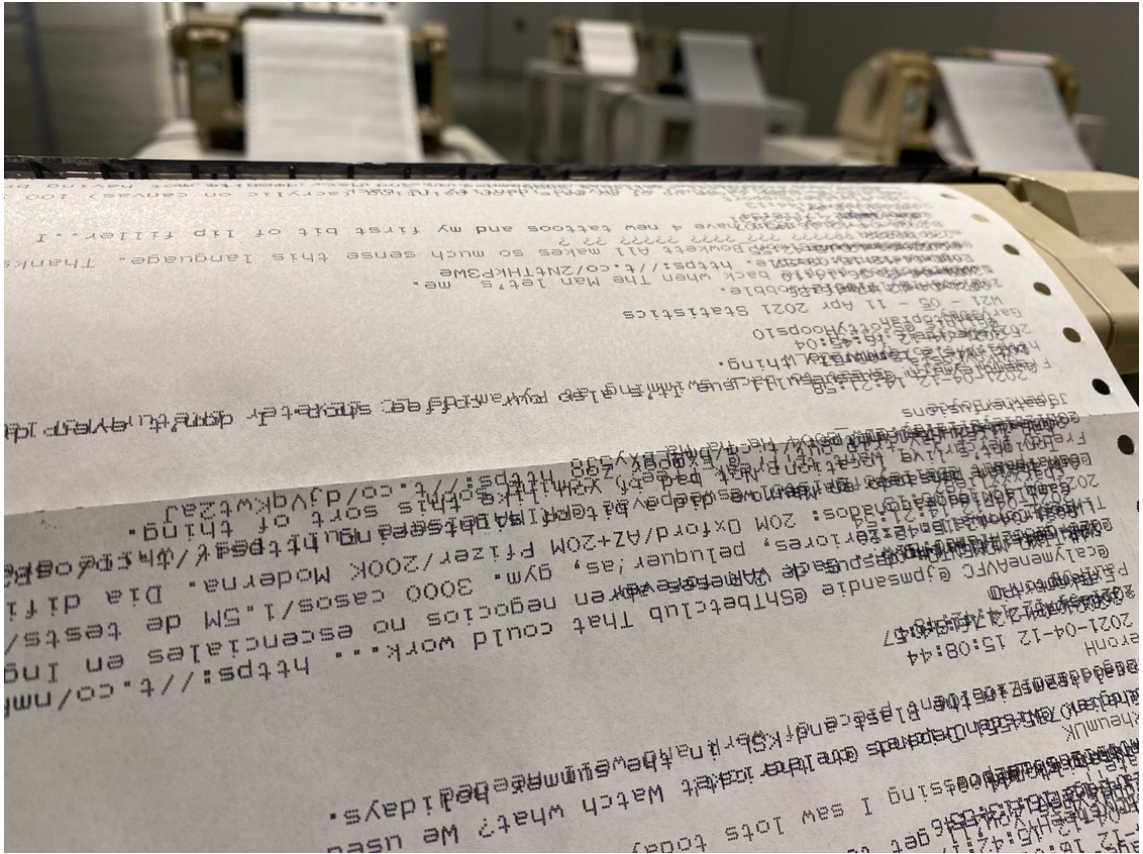

Figure 62: Misalignment on the printers in *[mis]Feeds #3* (Rosser, 2021).

data-based structure generated at run-time – the platform’s modality, which brings together images, text, video, and so on is different for every visitor depending on the settings (Manovich, 2001, p. 20). This suggests that there is more of an affinity between the lively printers and the indeterminate arrangement on the paper in my project with the energetic and diverse information that appears on Twitter. The low-quality print, nevertheless, struggles to keep up with the algorithmically determined information flowing from Twitter, so that the printed and unruly looping paper becomes

increasingly difficult to read. There is, however, amidst this tension, a sense of reciprocation between paper, machine, and online systems in this human-machine cross-talk. This resonates with what Latour says about the digital:

The digital only adds a little speed [to connectivity]. But that is small compared to talks, prints or writing. The difficulty with computer development is to respect the little innovation there is, without making too much out of it. We add a little spirit to this thing when we use words like universal, unmediated or global [...] which favours certain connections more than others (Latour, cited in Lovink and Schultz, 1997).

We could approach Latour's *spirit* as a process that vitalises the undetermined connections existing among nonhuman entities and machines, comparable to the potentiality and wonder of error (discussed in Chapters 4 and 5). In *[mis]Feeds*, likewise, the entanglement of analogue and digital might imply connections between all matter which are perplexing and obscure – such as the temporal cross-talk of different languages. The temporality of this space is guided by the spectrum between deviation and wandering mentioned in Chapter 5. The intermittent and idling printers are in ongoing negotiation with the live feed, and somewhat at odds with the fast pace and density of the digital information. This mediation emphasises the undetermined behaviour of the constituent parts in the project, thereby defining the independent behaviour of matter and its ability to act, evolve, and impact the material experience. Although my argument here does not prioritise individual matter

per se, the assemblage highlights the discrete power of things, which in *[mis]Feeds* consists of acts of mischievous mis-folding and mis-printing.

As a method of reproducing information, printmaking can be procedural, but if a typewriter key, paper, or printer ribbon is removed, it will not function *correctly* (Fig. 63). There are more complex agencies and experiences at play. In *[mis]Feeds*, for instance, our association of dot matrix printers with commercial print is juxtaposed against the experience of the printers as agents challenging prior understandings of efficient reproductive machines. As well as highlighting an abundance of online information, this is meant to encourage us to consider not just the prior human experience of printers, but how the experiences of the printers, paper, and ink transcend knowledge through collectively performing acts that convey needs and values outside of a human-centred frame of reference.

For an artist, such wilful acceptance and letting go of (certain) aesthetic conventions and dissolving fixities privileges a democracy of matter and meaning, in which 'there is no object, no subject' (Bennett, 2010a, p. 27), but rather, as my research outlines, a chance to change, to mutate, and to rearrange. In *[mis]Feeds*, printed error is active and self-organising, 'rather than

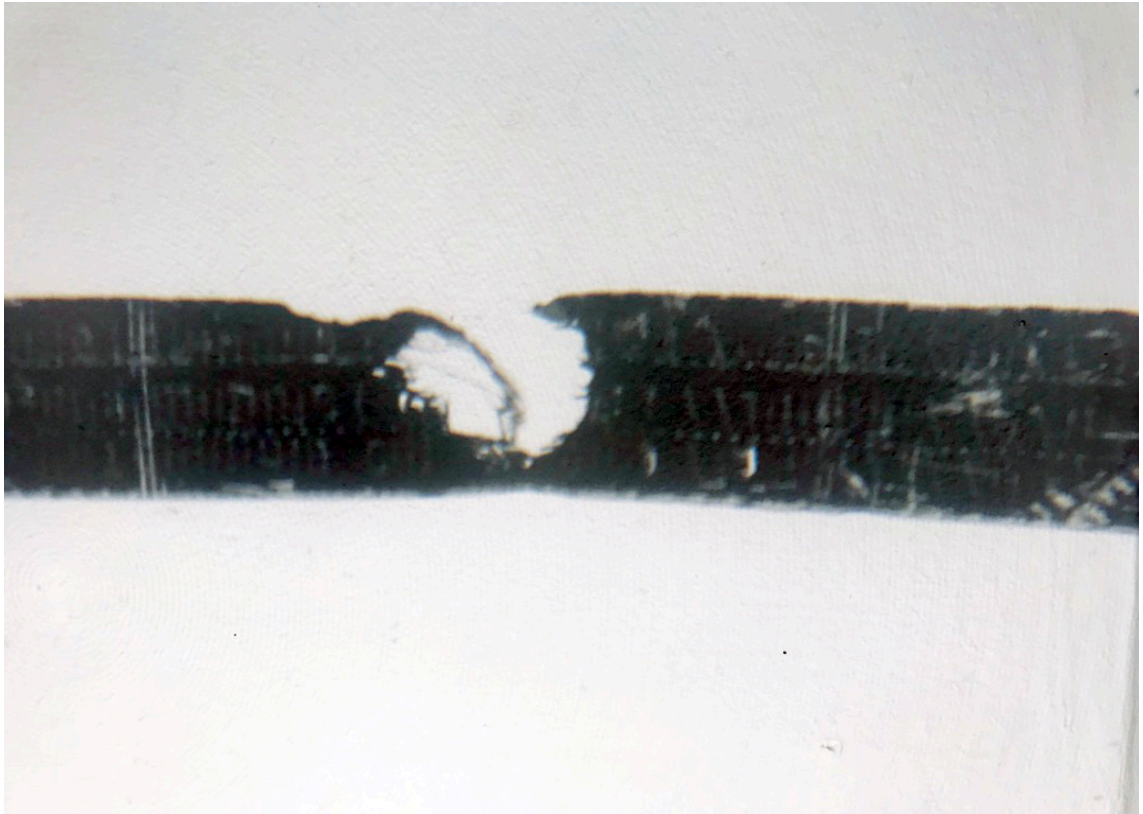

Figure 63: Printer ribbon tears due to fraught activity during an experiment in my studio.

as passive or mechanical' (2010a, p. 10). Distanced from the traditions of mechanical print processes, or systematic thinking, the printed matter and the printers themselves are able to resist passivity; this is brought about thanks to the complexities of uncertain relationships between artist, print machinery, and social media. My argument for the force of printed error echoes Bennett's proposition as error becomes something that 'is as much force as entity, as much energy as matter' (2010a, p. 20). This position challenges traditional discussions of the printed object and associated errors as inert entities.

#### 6.4 Print errors are resistant to automation

Bennett maintains that 'cultural forms are themselves powerful, material assemblages with resistant force' (Bennett, 2004, p. 348). I find her argument highly persuasive, in part due to her use of a creative vocabulary that includes terms such as *vibrancy* and *vitality*. This evocative language enhances my thinking on the type of energetic agency that error can contain. Yet the limitation, for me, of Bennett's philosophy in terms of errors' agential force is her reference to resistance, which becomes somewhat problematic in relation to error, since resistance is commonly allied with intent and is beyond the scope of error's agency. This is in contrast to my argument in Chapter 5 about error's wandering and deviation tendencies which encompass both intention and chance.

To complicate error's messy relation to resistance further, we can point to error's resistance to automation which Fox declares 'continues to digest the human world' (Fox, 2020). Error is opposed to and disrupts automated systems such as autocorrect, predictive text, voice assistants, traffic lights, or self-service scanners in supermarkets.<sup>77</sup> As explained previously in Chapter 4, error

---

<sup>77</sup> See *Copycopycopy* in the Appendices.

affects logical thinking and artistic practices which are associated with digital logic or formal technological systems, which Fazi portrays as 'bind[ing] both thinking and feeling into automated mechanism' (Fazi, 2019, p. 7).



Figure 64: Early five- and eight-hole punched computer tape (Coles, 2010).

Such mode of resistance, however, is less attuned with an 'inherited impulse' (Bennett, 2010a, p. 96), and is more of a responsive interaction between materialities. As when working with paper, which is commonly self-directing – imagine loading a ream of paper into a copier with one hand – one cannot predict what state it will be in when it leaves the printer. Hence *[mis]Feeds*, like

a computational system, has '*infinite* possibilities of endless loops', to use Fazi's words (Fazi, 2018, p. 122). My point is that paper is also *computable*, and indeed early computer programmes were written on paper, such as Turing's paper machines (Turning, 1950, p. 436), or punched paper as a type of data storage (Fig. 64). The continuous printed paper feed in *[mis]Feeds* function in a similarly way to punched paper, with both communicating information, or data. Even so, the overprinted entwining errors and boundless loops in my project are conventionally unknowable and resistant to reprogramming. The emphasise here is on how printed matter does not have to make sense; rather, the errant misprints draw upon future, present, and past experiences that are without end, summoning us – human, machine, ink – to expose new possibilities. The erring follies of looping information take the limitless mass of online information as their departure point to produce a literal form one can scroll through, yet only partially digest, if at all.

The printed errors raise questions about the agency of matter, which I argue can be appreciated as generating a productive form of break down. In *[mis]Feeds*, the printer's (relative) speed, while it frenetically and repeatedly overprints on the continuous paper, problematises societies' propensity to

pursue ever faster technology (print on demand comes to mind).<sup>78</sup> The potential speed of digitality contributes to this desire for instant results, and operates in parallel with human agency – expressed as thought, voice, and writing, for example. The looping paper feed merges the beginning and the end, reinforcing my claim that error, in the form here of misprinted information, can cause a cycle of breakdown and repair. On the post-digital reimagining of the machine, the theorist and writer McKenzie Wark suggests, ‘the machine has to go to its end and break down in order to then use its resources to build something else’ (2013). This makes one think of the energetic and cumulative momentum of errors in *[mis]Feeds*, as the impetus of the printed text fails and it reshapes into a type of corrigendum, in layers of mistakes. The tempo and ink density are increased, subtly at first, until the saturated paper tears and something new materialises. The cyclical, repetitive manner in which errors break down and rebuild meaning appears to be endless. Fazi writes of the potential of generative uncertainty (Fazi, 2018, p. 19) which reinforces the creative potential of error and its ability to reproduce ever more errors, each with its distinctive voice and effects.

---

<sup>78</sup> In a similar way, this is recognisable in the exhibition *Reality Errors* (2020) held at the Nam June Paik art centre. The curator writes of *Isang* and the momentum of humanity’s pursuit for new and progressive technology and connectivity, which is deemed as faster, smarter, and more powerful.



The printer's inherent qualities traverse between fluently communicating human and nonhuman agencies, and miscommunicating in, at times, unintelligible voices. Working in the tradition of actor-network theory, John Law writes of the instability of rendering meaning in another language, in that 'translation is always insecure, a process susceptible to failure' (2007, p. 6). The project *[mis]Feeds* reveals a similar mistranslation through converting the information from one medium to another, digital to analogue, internet to paper. The printers act as translators for the cross-talk of machine and human voices, giving rise to a tangled matrix of data and matter. This is beyond ideas of the fixed matrix in printmaking, or common associations with dot matrix printers, which I argue are uncovered by the emergent realisation of the agencies in the project, specifically that of error.

Through this rendering of agencies, I wonder, might the cross-talk between the printer feed and computer cables speak of concerns surrounding overconnectivity in a networked society? Returning to Bennett's interrogation of *thingness*, it is pertinent to repeat the question she asks: 'how can objects [things] sometimes be vibrant things with an effective presence independent of the words, images, and feelings they may provoke in humans?' (2011). Imbued with error, the printers in *[mis]Feeds* construct meaning in another language and beyond. This points to the ways in which error, in its vibrancy, permeates

an agency that is distributed throughout the project, extending its capabilities beyond humanity and exploring a material language that is outside of conventional linguistic construction.

In my attempt to uncover the distinctive, and disruptive, abilities of print errors in this discussion and in my project, care is required when thinking about how best to describe its vibrancy, without 'erasing the independence of things' (Bennett, 2010a, p. xiii). The entangled agentic materialities in *[mis]Feeds*, between error, humans, and nonhuman others, allows error's vitality to offer an account of both its autonomy and behaviour. It is the transversal actions of error that are revealed through its multiple links within the project. In *[mis]Feeds*, error cuts across both anthropocentric discussions of the object and materiality, and nonhuman unintelligible voices and behaviours that are beyond semantics. This discussion does not attempt to provide a prescriptive account or a catalogue of error's actions and modalities. My aim, rather, is to expose the potentiality of *misfeeds*, in anticipation of the agential materiality of the errant text and the network of other voices it activates, which is a central theme of the following chapter.

## Chapter 7: Relationality

In the previous chapter, I explored the lively agential potential of error by drawing on my print-based practice, as well as new materialism and actor–network theory for their useful reconceptualisation of agency. Foregrounding error’s relationality, specifically when it concerns the relations between humans and nonhumans, this chapter examines the nonhuman agencies at play in my project *[mis]Folding*. The first section of the chapter advances on the theoretical discussion developed in the previous chapter by giving further thought to my claim that error is part of a wider, complex network of intertwined relations. The project *[mis]Folding* is a focal point of this chapter as it operates as a map of these relations. It represents the collective effort of folding actions and instructions, screenprinted marks and the folded surface, which are instrumental in the creation of error’s relational agency. A distinctive feature in the framework of this chapter is the suggestion that error’s agency only activates through a network of interactions. As such, error’s co-constituted agency is examined in the second section of the chapter. The discussion in the third section outlines the underlying temporality of error’s connections throughout the process of becoming. This is followed by an analysis of the efficacy of error and its liveness, and concludes with a discussion in the fifth section of the chapter on error’s ability to expose contingency. My project

relies on a broad definition of agency, which explains the choice of leaning on new materialism for its emphasis on vitality and enmeshed agential powers, and actor–network theory for its promotion of constantly shifting networks of people and technologies.

### 7.1 The potentiality of the agentic network

The actor–network theory’s resonance with post-digital conditions is beneficial in examining more closely the interaction between error and print technologies, which is why I am using it as a theoretical framework for my research. Whilst the opening discussion on the network may seem somewhat simplistic in tone, it serves an essential purpose in structuring the debate on relationality. Latour’s focus on the sociality of the network has proved to be insightful in my understanding of the complexities of the collective agencies in *[mis]Folding* and the relationship between analogue and digital print technologies in my wider set of projects.

If we consider, as David Berry and Alexander Galloway suggest, how ‘everything is a network’ (2015, p. 154), through which we (humans and nonhumans) communicate, unfold, exchange, and mutate, it can be concluded that we are all part of ‘systems [that] are open, dynamic, and robust’ (2016, p.

8). Yet, *network* as a term should not be taken for granted,<sup>79</sup> as it is complicated and, according to Latour, can be misleading:

While twenty years ago there was still some freshness in the term as a critical tool against notions as diverse as institution, society, nation-state and, more generally, any flat surface, it has lost any cutting edge and is now the pet notion of all those who want to modernize modernization (1999, p. 15).

How then do we discuss the network, and network-thinking, if not through the network itself? Whilst it is hard not to disagree with Latour about the term's over-use, and at times its misuse – when employed to describe almost any situation – his 'long live flexible networks' campaign (1999, p. 15) has currency as far as my thesis is concerned, given how I advocate adaptable interactions between error, print, and analogue technologies as active, networked things.<sup>80</sup> The network remains rooted in 'contemporary understandings of the specificity of digital technologies in social life' (Berry and Galloway, 2015, p. 1). Even so, Berry refers to the method of using 'non-media' – or *low-media*, I suggest, as a more apt term for my projects and their use of equipment with low fidelity – as an artistic 'rereading of the [post-]digital' (Berry and Galloway, 2015, p. 152).

---

<sup>79</sup> The network is so ingrained that we cannot think beyond the network. 'There is no way to think in, through, or beyond networks except in terms of networks themselves' (Berry and Galloway, 2015, p. 157).

<sup>80</sup> While the term may have lost its critical edge in actor-network theory, networks have simultaneously become more important everywhere else. Post-digital perspectives, in particular, foreground the importance of networks.

He maintains that ‘the “network” has become a key concept for understanding an increasingly postdigital age’ (2016, p. 1). Indeed, in its association to networks, post-digital print error can be understood through its capacity to act in a social structure consisting of actions with people and technologies, rather than through discreteness or inertia.

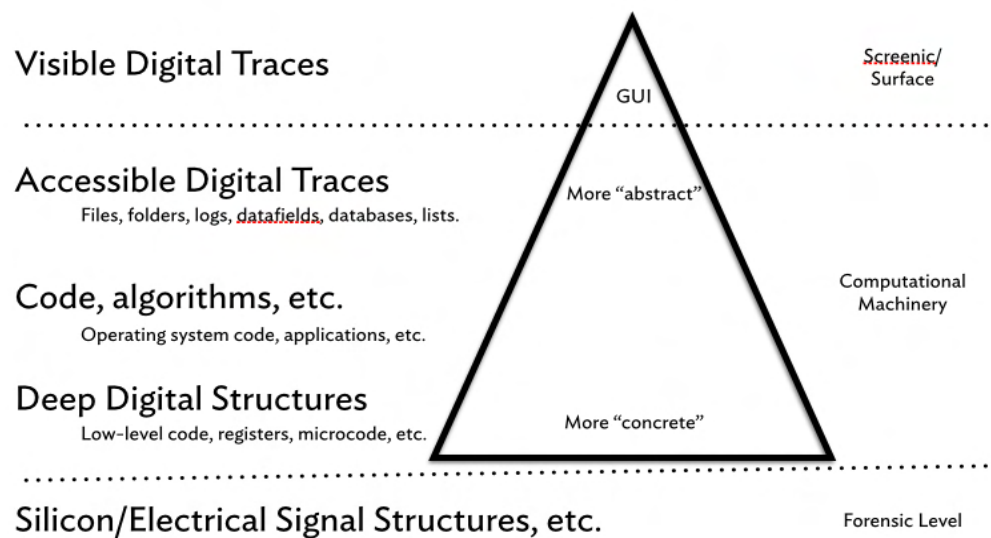

Berry, D. M. *The Digital Iceberg* (2014)

Figure 65: *The Digital Iceberg* (Berry, 2015b, p. 47). © David Berry. Permission granted by David Berry.

The part of Latour’s argument that Berry uses to further his point about networks is the idea of the digital as the socio-technical component of the computational tool, represented in Berry’s iceberg diagram as an interface of

visible digital traces (Berry, 2015b; Fig. 65). In my project, the paper surface presents a similar arrangement, albeit without the hierarchical structure of Berry's diagram, and is instead comparable to the organic disorderly arrangement of the diagram itself, which is further complicated by the folds of information in time and space (see User Guide). Folding is thus one of my methods for exploring agency through relationality. At the same time, this network of agencies does not pertain to the restrictions of two- or three-dimensional structures, and errored actions span beyond time-space-place. In *[mis]Folding*, the network of screenprinted marks on the paper surface unfold, fold in, and fold out, encouraging us to consider the wider influence of relationalities and agencies in a network and error's inherent relationality. Throughout the project, my body seeks to understand the fabric of the instructional script that sounds like a series of glitches in a computational structure (Fig. 66). The screenprinted diagram allows me to gain access to deeper material agencies, and we can see in Fig. 67 one of my attempts to make sense of error's relational effects, which unfold and make new collective meanings.

My enquiry into relations in *[mis]Folding* is guided by instructions, which exist in two modes: firstly, the spoken script; and secondly, the diagram, which can also be appreciated as instructional. My folding is a response to both elements



Figure 66: *[mis]Folding* (Rosser, 2021). Documentation of attempts at folding a diagram in response to the reading of errant instructions on how to fold a map. Image: courtesy of Helge Mruck.

(see User Guide). Reflecting on the diagram in this way provides a non-linear set of instructions on the relations and agencies at play. The screenprinted marks, whilst inconsistent, are reminiscent of musical score sheets (see Fig. 67), highlighting the relation between my diagrams and instructions. The simplified systems of marks on the screenprints are set out to explain how the conditions of the project are connected. I am guided by both the spoken and diagrammatic systems. Both sets of instructions inform my actions, which in



material terms are inaccurate, misfolded, and conceptually create overlap, blurriness – in turn, relations become multiplex.



Figure 67: Attempts at folding-unfolding-misfolding a series of screenprinted diagrams during a residency at Bolton University (Rosser, 2018).

## 7.2 Co-constituted agency

A relational approach to agency reveals a network of complex connections, with artistic actions, print process, screenprinted error, and speculative thinking about interconnected materialisms merging to *co-constitute* a whole network of networks – the project, in other words. These entanglements are reflected in my use of diagrams, which emphasise the relationality of the composing elements.

The network is productively flexible and indicates how the entanglement – to borrow a term from new materialism – of elements fluctuates depending on the situation, idea, or motivation. Such a fluid interpretation of the network results in the human, or artist, no longer being the sole agent capable of action, and the shared agency or responsibility coproduces a creative uncertainty (as elaborated in Chapter 5). This is revealed in *[mis]Folding* where paper and actions are re-formed through interacting with error, affecting human and nonhuman bodies – between my errant folding and the misfolded printed matter – in ways that are unknown and unintended.

In *[mis]Folding*, everything is entangled; or more precisely, error, paper, and print intertwine in a wider network with intention, knowledge, and actions that

prevent independence or a sense of social order while emphasising relations. Wark posits relationality as a contemporary phenomenon, where knowledges, actions, and experiences weave together. She states how '[a] problem of our time is knowledges don't have hierarchies, they have relations', asking: 'So, what's the non-hierarchical relation between different knowledges that do different things?' (Wark, 2013).

The entanglement of agencies which exists between all things, includes of course the role of error in printmaking. My practice and thesis rely on this conception, where error is active and has fluid relationships across complex borders, through linkages, gaps, flows, and forces.<sup>81</sup> The collective entities perform together, they cross-talk, and have the power to act and produce a networked form of agency which evolves during each repetition of the project – between 2019 and 2022. When the various components interact, the network disperses different effects, or *contingency* (to be discussed in 7.5).

---

<sup>81</sup> Latour expresses that 'a network is all boundary without inside and outside' (1996, p. 372) However this raises questions about the connection between states, and he explains how 'the surface "in between" networks is either connected – but then the network is expanding – or non-existing. Literally, a network has no outside. It is not a foreground over a background, nor a crack onto a solid soil, it is like Deleuze's lightning rod that creates by the same stroke the background and the foreground' (Latour, 1996, p. 372).

Error's agentive acts are facilitated in the project through a network of knowledges and encounters, the command of the paper, the experience of the reader, and the viscous conditions of the offset screenprinted ink. As can be seen in Fig. 68, folding mistakes are unavoidable, regardless of whether my ambition is to align the paper edges with the folds or the printed highlighter marks. As Gell writes, art objects are not self-sufficient agents, but agents that have effect by virtue of being enmeshed in social relationships (1998, p. 17). Likewise, the misfolded diagram emerges as a means for me to explore the dynamic relationship between error and its constituent parts within its network of operations. The spaces, or voids, between printed information acquire associations of uncertainty, reminding us of what we don't know (see Chapter 5), and the expansive relationality of (online) information.

Latour similarly focusses on what an object or thing acquires, rather than its prescribed function. He argues that this *material agency* (see 6.1) is in a state of perpetual multiplication as it evolves into new combinations (Latour, 1993, p. 1–3). Such mutation can be perceived in *[mis]Folding*, where each time I engage with the spoken and diagrammatic folding instructions, something new materialises. Rather than drawing solely on human knowledge and experience, or material experiences of error as fixed or simplistic mistakes, the project



enables errors to disperse agency. It paves the way for a creative experience between bodies, printed matter, and the script, which acts as a provocation towards unknowing and unlearning.

Chapter 6 introduced the idea that there is a connection between 'the way we make errors, and [how] in turn errors make us' (see 6.1). This statement is fundamentally relational and warrants further attention in terms of my claim that the agentive actions of error and humans are capable of traversing all senses of direction, and how in our interconnectedness we can both be *prescribed* agency and be *prescribers* of agency. Here there is no space for the individual, and the proposal of a fluent social system in which error can fluctuate across a network is especially creative. It underpins my ideas of a network in which error influences material and human decisions. In this networked space, we can be artistically and recklessly unsure. Drawing on Bate's idea of errors being replaced with new errors (2002, p. 35), *[mis]Folding* demonstrates how my tentative and malfunctioning folding actions interact with error as a way of collectively finding or stumbling across new relations.

This manner of apportioning agency can be embodied in the way error acts in my practice. Latour and Berry's perspectives on networked agencies differ in terms of hierarchies, whilst sharing similarities. There is a tension between

Berry's formal socio-technological hierarchy (introduced in 1.3) and Latour's distributed approach to agency. Notably, 'the network in Latourian terms avoids the problem of patriarchal power as its own agential network in its situating of the relational' (Coleman, 2018). Latour centres on unfixed and emerging relationality over Berry's predetermined and fixed social scale – Berry takes issue with Latour's apparent dismissal of power imbalances. My position broadly corresponds with Latour's emphasis on dispersed agency; for example, in *[mis]Folding*, error's entangled connections are positioned in a fluid social stratum. They are not discussed in terms of their ability to conform to a predetermined structure or system of categorisation (see the earlier diagram, Fig. 55), and this presents error as capable of circulating agency within an emergent agential field.

The notion of dispersed action reflects Latour's idea of 'distributed agency' (2005), where agency is shared between humans and nonhumans rather than being assigned to an individual entity:

Action is not done under the full control of consciousness; action should rather be felt as a node, a knot, and a conglomerate of many surprising sets of agencies that have to be slowly disentangled [...] Action is other-taken! So it is taken up by others and shared with the masses. It is mysteriously carried out and at the same time distributed to others. We are not alone in the world (Latour, 2005, pp. 44–45).

Latour suggests such tangled interactions 'cannot be accounted for by the initial actants' and are instead the arrangement that produces something *new* (McIntyre, 2015, p. 13); this resonates with Bate's reference to error creating new error. There is congruency in this point with the emergent and agential nature of error, between my artistic intention for the folded paper versus the outcome and resulting folded paper. It can be reinforced by Latour's argument that the 'conglomerate' of agencies does not belong to a single actor – not me, the paper, the reader, the room, or the script – but is the possession of the relationship or network itself, as a 'circulating entity' (Latour, 2005, p. 132). This helps to further stress the synthesis of relationality:

Objects forming and emerging within relational fields, bodies composing their natural environment in ways that are corporeally meaningful for them, and subjectivities being constituted as open series of capacities or potencies that emerge hazardously and ambiguously within a multitude of organic and social processes (Coole and Frost, 2010, p. 10).

Such an account of agency and dynamic social structure supports my argument on how errors, printed marks, paper, and folds can dynamically co-constitute each other. Namely, dynamic agentic errors constitute the embodied social structure, and the embodied social structure constitutes the dynamic agentic errors. As a consequence, error cannot be autonomous and is only active as part of a larger relational form of agency: *co-constituted agency*. This is distinct from a commonplace understanding where things or matter can exist



independently. My practice is not composed of distinct parts such as my intention, print technologies, printed matter, and the outcomes; rather, these interact with each other constantly. Indeed, error, intention, knowledges, action, process, and printed matter are *co-constituted* by their interactions in the social fabric of the project.

The key point here is that error cannot exist as a single independent thing, since error's agency is produced through the co-creation of the messy relations between the things in the network which together constitute the project. The agency of error exists at the point of convergence in the network, through relations. To be specific, error acquires agency when it interacts with humans or nonhumans. This encourages a rethink of the way we perceive error as a part of the wider relationalities at play in printmaking, including the historical, political, and cultural impact of the printed surface.

Concerning the concept of entanglement and the network, what emerges as important in *[mis]Folding*, and this discussion more broadly, is the significance of error's interconnection with other constituencies, as well as the networked space where error is actualised through its dynamic interactions. Centring on errors' co-constituted relationality permits an exploration of the social, imaginary, and material dimensions of artistic expression. In its vibrancy, error's

network is capable of producing emergent behaviour, and can adapt and reshape depending on the ideas and actions at play.

This relational perspective is supported by Barad's description of how meaning can be determined through 'agential intra-actions' (2003, p. 815). In *[mis]Folding*, it is the actuality of specific errant actions that becomes meaningful. Error is thus characteristically entangled and emerges between actions and objects as *intra-actions* of human and nonhuman bodies (Barad, 2007, p. 141; Barad, 2003, p. 815). It should be noted that Barad's concept of 'intra-activity' (2003, p. 818) is distinct from my use of the term interaction, which I have used in this chapter to determine a reciprocal action.<sup>82</sup> My approach differs from hers in this regard, as I assume that *interaction*, like *intra-action*, does not draw on pre-existing relations in line with Barad's 'relata-within-relations' (2003, p. 815). Barad defines intra-activity as capturing dynamic relationalities, and notably describes how meaning can be determined through agential intra-actions (2003, p. 815). This underpins my proposition

---

<sup>82</sup> Barad writes: 'relations are not secondarily derived from independently existing "relata," but rather the mutual ontological dependence of "relata"—the relation—is the ontological primitive. [...] relata only exist *within* phenomena as a result of specific intra-actions (i.e., there are no independent relata, only relata-within-relations)' (2003, p. 815).

that in the project *[mis]Folding* it is the actuality of specific errant actions that is meaningful.

In *[mis]Folding*, new meaning is determined through the dynamic topology of actions, drawing on Barad's argument for 'intra-acting' agencies where dynamic, independent things or phenomena are created through agential intra-actions (as explained in 7.1).<sup>83</sup> Barad considers *matter* as capable of 'reconfigurings/entanglements/relationalities/(re)articulations' (2003, p. 818). This assembly of terms parallels the entwined conditions in my project; however, the capacity for change is enhanced by the disruptive properties of error. According to Barad, all matter – from the smallest phenomenon to the physical force between paper and screenprinting squeegee, for instance – come to matter through 'intra-activity', which implies that matter is active and is engaged in continual materialisation (2003, p. 822). This is not to be confused with, or in any way relates to, my reference to *printed matter* (see 1.2.1), which one might associate with physical printed material. Barad's *matter* is not necessarily something with a physical materiality, but rather: 'Matter is substance in its intra-active becoming—not a thing, but a doing, a congealing

---

<sup>83</sup> *Phenomena* are the smallest material units, similar to Barad's relational 'atoms' (2003, p. 822).

of agency. Matter is a stabilizing and destabilizing process of iterative intra-activity' (2003, p. 822). Such conception of matter is a practice of co-constituted agency between materiality and cross-talk. The *matter* at stake in my project is the situation that is under consideration, and the entangled parts are determined by their intra-actions. The relational network of humans and nonhumans in *[mis]Folding* sees error destabilise actions and the paper shift material properties. Returning to Deleuze's proposition, error is in a perpetual state of *becoming* (which is further explored later).

The performativity of these agential things is elaborated further in Barad's discussion on language and matter, which captures the dynamic cross-talk between things, since 'agency is a matter of intra-acting; it is an enactment' (Barad, 2003, p. 826). The argument that agency is a matter of doing or being between social forces that cannot act independently strengthens my position on relationality as a means to understanding my project. Can error be described independently of the constituent things it is connected to, such as the viscous ink, pressure, temperature, or the politics of the printed page? On the contrary error's co-constituted agency emerges across and between modes of human and nonhuman interactions. In my project, error is approached as an *apparatus*, as Barad would call it, or as a raw material – viz. speculative thought or a screenprinting screen – as they play an essential role in producing new

bodies and meanings.<sup>84</sup> My aim in my practice is to be responsive and sensitive to relationality and the way error transforms, rearticulates and reconfigures meaning, as an act of becoming which is discussed in the following section.

### 7.3 Becoming error

Following Deleuze, it can be argued that error is immanent in printmaking practices. In its ubiquity, error uncovers new trajectories and undetermined relations. The aim here is to draw attention to what printed matter – and other related things in *[mis]Folding* – acquire through the relationship with error, rather than subscribing to conditions of histories, culture, or politics. This understanding of error as capable of affecting change through its relationality calls to mind, once again, Deleuze's concept of *becoming* (1995, p. 171).

Although this idea was touched upon in Chapter 5, it is important to expand it here in support of the ways in which relations unfold in time. Whilst becoming is not a central part of my argument, the concept reinforces error's ability to open and alter relationships, as it points to the production of something new

---

<sup>84</sup> Bohr gives an account of *apparatuses* that are 'particular physical arrangements that give meaning to certain concepts to the exclusion of others; they are the local physical conditions that enable and constrain knowledge practices such as conceptualizing and measuring; they are productive of (and part of) the phenomena produced; they enact a local cut that produces "objects" of particular knowledge practices within the particular phenomena produced' (Barad, 2003, p. 819).

and unknown (Deleuze, 1995, p. 171). Therefore, the following discussion explores becoming as a dynamic and non-linear process of change (Parr, 2010, p. 30), for example through the connections in *[mis]Folding* between marks and folds that organically evolve in *real-time* (as discussed in 7.1).

What is especially pertinent to my research is that becoming is not a part of history (Biehl and Locke, 2010, p. 317). Deleuze describes how 'history amounts only to the set of preconditions, however recent, that one leaves behind in order to "become," that is, to create something new' (1995, p. 171). In doing so, becoming might serve to account for the function of new relations, and whilst it expresses similar ideas to Barad's *matter* in dynamic relations (discussed in Chapter 6), Deleuze focuses on becoming's receptiveness to movement and change within the *assemblage*. Deleuze explains how in becoming 'one can achieve an ultimate existential stage in which life is simply immanent and open to new relations—camaraderie—and trajectories' (Biehl and Locke, 2010, p. 317). Although I acknowledge a productive sense of togetherness between myself and print-related things, such as those I spend time with in *[mis]Folding*, I am also aware that error disrupts this connection. This disruptive sway creates opportunity for focusing on the affordances of uncertainty and becoming. The process of opening oneself up to this *erroneous* discord sees the paper misalign due to error's influence on the

position of the printed marks and my actions, which are rendered incompatible, and it creates a friction between my intension and the grain of the paper.<sup>85</sup> My learnt actions and imagination, as well as the printed matter, are all influenced not just by one another, but by error's productive resistance and tension in its relationship with other entities. Through the interference of error, one can distinguish how the collective forces – myself, print process, and error – start to become something different. As the theorist Ronald Bogue puts it, '[o]nly by becoming "other", by passing between the poles of binary oppositions and blurring clear categories can new possibilities for social interaction be created' (2010, p. 171). Error thus amplifies problematic interactions in a network, a welcome challenge to ideas of *camaraderie* in artistic practice between artist, material, and ideas – perhaps interpreted as a perfectly executed fold or print that matches intention. In short, error facilitates new and messy paths, and obscures known outcomes or categories and friendly relations. This can be perceived as error enhancing new ways of working in print, where the possibility of error and creating something *other* (than planned) becomes plausible.

---

<sup>85</sup> Folding across the grain of the paper creates a resistant force.

The idea of becoming is useful as it helps me to articulate the transformative powers of error's relationality in my practice. The focus on the interactive experience, which holds similarities to Latour and Bennett's assemblages discussed earlier, shifts the discussion away from distinctions in art between object and subject – prevalent up to the 1960s (Parr, 2010, p. 30). It also helps me to understand the errors that surface in my project as contributing to a milieu of unstable social forces which, since this project is durational, become transformative in *real-time*. This is an important point. There is a creative value to the durational situation of *[mis]Folding*, as it is via the process of repetitive and prolonged acts of folding – without a definite end – that transformation occurs. The following statement by the philosopher Adrian Parr writes resonates with my argument:

The art is in the 'becoming of art' that is in itself social. Art of this kind may be best articulated as 'art without guarantees'; this is because it exists entirely in duration and amidst the play of divergent forces (2010, p. 30).

In view of earlier discussions, Parr's interpretation of durational practices as open-ended provides the opportunity for repetition to act as a method for accessing error's dynamic forces and correlated transformation. The variations happen in the moment with each attempted fold, suggesting that becoming is a continuance of new and differing agencies. Correspondingly, during the span



of the project, relationships and forces change between the artist, viewer, and sites, blurring time-space-place distinctions.

Transformative errant conditions are thus realised through duration in *[mis]Folding*. The project creates scope for multiplicity, which is itself ingrained with error. Yet the actions in *[mis]Folding* are also joyfully impermanent, conflicting with histories of printmaking and editions of printed information. This invokes my earlier point that becoming is not aligned with histories, and is instead concerned with marked changes in the present and in anticipation of the future.

#### **7.4 The liveness of error**

In *[mis]Folding*, the flow of new creative trajectories and forces occurs live. This liveness exists within the community of relations, momentarily unifying to make a whole, only to re-fold, and become something other. I am sensitive to error's capacity for reshaping through its *liveness* (Soon, 2016). What I mean by *liveness* here refers to the temporality of error, and is distinct from the previous discussion (see 6.2) where *liveliness* centred on vibrancy. Error's creativity stems from the live encounter between the assemblage of human and nonhuman bodies in the project. Hence, one might think about the

characterisation of error in artistic practice. With the previous chapters in mind, we need to move away from understandings of print error as discrete and the focus on the individual or the independence of things (Deleuze, 1994; Boundas, 2010, p. 131), and instead prioritise the relational forces of error and its varied and disruptive effects (or creativity) which transform in the moment of their becoming.

Invoking Deleuze's becoming, the artist Winnie Soon writes of how 'different forces, not a single entity, constitute the notion of liveness as a plane of immanence' (2016, p. 37), and she defines liveness as fundamentally unpredictable (2016, p. 39). In my project's liveness, error permeates potentiality, and because of its uncertainty, as Soon claims, anything becomes possible (2016, p. 39). The liveness is visible in the project and through my nuanced understandings of relational agency that happens in the moment of its encounter. Liveness is inevitably associated with the speed of digital technology (Soon, 2016, p. 41), although it also accounts for the relationship between humans, nonhumans, and machines in *[mis]Folding*. Soon defines the way 'technology becomes live [...] not only for us but also for-itself and for other beings that are beyond the scope of human reasoning and understanding' (2016, p. 41). This vitality holds true beyond technology, it suggests efficacy, and is something my projects and post-digital ideas try to

also uphold. As Soon alludes, there can be many dimensions to live transformations. In *[mis]Folding*, errors emerge from spontaneity as human and nonhuman knowledges unfold, re-fold, misfold, thus changing the arrangement of the assemblage. Soon talks of unpredictable events as 'happen[ing] while an event or a process is unfolding in real-time' (2016, p. 38). This idea of *real-time* – which is somewhat problematic in itself – exposes a tension between liveness and unpredictable print-based activities, and associations of printed static matter (see 4.1). My research contributes to the exposure of this tension by understanding error as capable of giving rise to new and uncertain effects.

Thus far, this thesis has built an argument on how error engenders uncertainty. Error can be recognised in *[mis]Folding* as generative and giving rise to mistakes through repetition. While, Chapter 6 included Fazi's account of 'generative indeterminacy' from the perspective of digital computing and coded structures (2019, p. 9), it is worth reflecting further on her argument that 'the dynamic and generative power of sensation contrasts with the static nature of the formal, finite and binary means through which the digital computing machine harnesses the lived' (2019, p. 9). It would require one to take a conceptual leap to re-interpret this in terms of *error* and *print*; still, an error is also unpredictable and emerges from contact with, to borrow Fazi's use of the term, 'formal' things in the project (2019, p. 16). An outcome of *[mis]Folding*,

also outlined in this discussion, is that one becomes cognisant of error as having the ability to initiate or cause change. In doing so, error can be seen to be immanent and unfold real-time in *[mis]Folding*. This idea of error's persistent and continuous uncertainty interlinks Fazi's generative *indeterminacy* with Soon's *liveness* in a way that emphasises the unpredictability and immediacy of error.

Error is in itself ambiguous. Yet through merging with matter and things within the project, it yields different generative capacities and eventualities – packaged together as errors-in-action, printed diagrams, or audio instructions. The suggestion here is not that because of its ambiguity *error* is a conceptual, free-for-all term, but that because of its liveness error remains indeterminate and contingent.

### **7.5 Error enacts contingency**

So far, this chapter has defined how error plays a vital role in my practice due to the relationality of its constituent parts. Error brings into effect what I call a co-constituted form of agency, inasmuch as its agency is only realised in the moment of its *intra-action* (Barad) with paper, my action, printing ink, script and so on. This is a significant point of this thesis, and prepares the basis for the

argument in the final section of Part Three which introduces the notion of contingency.

Contingent error encapsulates essential properties of being uncertain. This is true of the way error cannot be predicted in *[mis]Folding*. It can be anticipated, if certain events and relationships emerge through such acts as attempting to align misaligned printed marks or following errant folding instructions.

However, its specific intrinsic characteristics cannot be experienced or known until the point at which it is realised. In *[mis]Folding*, the contingency arises through the hybrid existence of error along with other things, and the project evolves by these changing and flexible relations.

Although developed in reference to computation, Fazi's analysis of contingency and indeterminacy can also be applied to error as something that

has its own way of being profoundly indeterminate. In other words, it is contingent. [...] Contingency is thus conceptually separated here from empirical qualities as well as from an existential or personal point of view (2016, p. 28).

Fazi's allusion to empirical characteristics highlights the value of my projects as methods to observe, and experience first-hand, errors-in-action. Whilst beyond the scope of this research, Fazi's differentiation between empirical and formal dimensions of indeterminacy in computation (2016, p. 20) are important in

terms of error. Her discussion of the void between the ideal, or formal, and empirical (Fazi, 2016, p. 25) interests me because of the variables of errors which are, as this discussion and the project reveal, unpredictable rather than axiomatic in character (2016, p. 19). This idea reinforces the earlier point in Chapter 4 that error cannot be reduced to logic alone. Returning to the idea of *becoming* (discussed in 7.3), where the social is dynamic and changeable and exists in a project's unfolding in time, I distinguish parallels with Fazi's indeterminacy that point to my creative encounters in *[mis]Folding* where errors are also seen as contingent.

Fazi describes how in computer software there are 'infinite possibilities of endless loops in a program [...] beyond the finiteness of the time-constrained procedure constructed to infer its fallacy' (2016, p. 26). She persists in reminding us that computational software is never totally bug-free (2016, p. 26) or glitch-free (see Chapter 4), and evidently nor is my project. If one considers the offset screenprinted marks within the edition of my printed diagrams alongside my errant actions of folding-unfolding, *[mis]Folding* presents seemingly endless possibilities – until the paper eventually breaks down completely or another unexpected thing occurs (Fig. 69 and Fig. 70). At the same time, as Fazi notes, it is not until the programme – or my artistic folding – is performed that we can uncover its faults (Fazi, 2016, p. 31). In my durational

and repetitive looping actions, the paper folds, curves, kinks, arcs, twists, and zigzags in and out of itself. Here contingency becomes the unbounded condition of the error.



Figure 69: Screenprinting the edition of 50 diagrams at Neo Print Studios, Bolton (Rosser, 2018).

Contingency is deeply woven into error, and so it is also woven into all the projects that form part of my research. My concern is to show the indeterminate agency error affords. Neither the error, nor the printed paper, or I are predictable in our actions. The agency is defined and actualised in the

interstice between my artistic intention, and the folding or printing actions and errors that occur (see Chapter 4 for a discussion on the way error transverse



Figure 70: *[mis]Folding* (Rosser, 2021). Detail of folded paper, which eventually breaks down. Image: courtesy of Helge Mruck.

this in-between space). It is this point, this in-between space, the interstices, that fosters the contingency of error. The project is meant to create an opportunity for potential exposure to the juncture, the folds between intention and error.

Cocker writes of the possibilities of being prepared for contingency:



Once again, the not known situation is imagined to harbour some potential risk or threat, which contingency plans attempt to diffuse or neutralise by preparing for the worst, Yet, there are practices that plan for contingency in other ways, whose anticipation of the unknown is hopeful rather than delimiting (2016b, p. 69).

This statement reminds me of the value of optimism in *[mis]Folding*, in which errors demonstrate both contingency and generative potential. In the project, it is in this *interstitial space* of relationality where the agency of error exists, as an aesthetic fissure, an opening between error, print, and my actions (Fig. 71). It is only through error's contingency and co-existence in this interstice that its agential characteristics are actualised and registered. It is only through its relationality with the ink, paper, and my artistic actions and ideas that error acquires knowledge and meaning. Crucially, this is the precise point at which error's agencies are realised, belonging neither wholly to myself, paper, fold, or error. The agency as such is a manifestation of possible relations in space and time, a folding between human and nonhuman things, between contingency and error.



Figure 71: Installation of *[mis]Folding* (Rosser, 2021), at the Arts Institute of the University of Plymouth. It exposes the intersect between error, print, and the artist's actions. Image: courtesy of Helge Mruck.

## Chapter 8: Error in Post-Digital Print

This practice-led research has aimed to provide unique contributions to the expanded field of printmaking, through researching creative and theoretical understandings of the potentiality of error in post-digital print. This context of the potentiality of error has been problematised by working with, and exposing, print technologies in new and different ways. My print-based practice, diagramming, exhibitions, and this written thesis have together created space for the agency of error and for previously unknown relations to emerge. The errors in the projects have guided my thinking, in parallel with an exploration of key concepts including the post-digital, agency, and relationality. These have helped to frame the significance of the practice as a demonstration of errors-in-action.

It has not been my aim to present my thesis as a work of philosophy, but an exploration of ideas in a more speculative manner, where the practice is blended with theoretical commentary and reflection. In doing so, the main written work has been designed to form a linked narrative to my practice, which itself has been developed by its interconnections with my writing. In addition, the practice of diagramming has provided me with a means to explore and map out relationships between the constituent parts, and to form

bridges across my thinking, in both the artistic practice and written text, and even to erode the distinctions between the two.

This conclusion – and I hesitate to call it that, as it seems to be too determining and final a definition – also functions somewhat diagrammatically by drawing lines of thought together and exposing the relations between the various strands of my research. These include: the creative possibilities of post-digital print and how error can be understood differently as a consequence (Part Two); and the significance of error's influence, its agency, and its relationality (Part Three). As might be expected, the borders between the various chapters are porous, creating crossovers and entanglements between my practice and thinking, but some key terms emerge which are significant, such as: potentiality, misadventure, co-constituted agency, and contingency. In what follows, I summarise these key findings, point to where I will take my research next, and finally return to the artistic practice that embodies these ideas as *errors-in-action*.

### **8.1 Error opens up imaginative potential**

This research has uncovered how errors in print are understood differently as a consequence of post-digital systems, practices, and cultures. Chapter 4 and my

project *Enchiridion* problematise the way artists think and feel about printmaking errors under post-digital conditions, and establish how analogue and digital technologies are intertwined. *Enchiridion* exposing how a focus on error and entanglement provides a creative means for escaping the limitations of digital logic and rationality, reinforcing some of the complexities of our relations with print technology. The unpredictability of error in *Enchiridion* becomes a way to question systematic digital logic and rational thought as foundational constructs.

My set of print-based projects are typically low-tech, making use of relatively simple means to connect and distribute information between old print equipment, paper, and the internet. Error is activated by the practice itself, through the messiness of entangled human and nonhuman relations.

Printmaking is inherently seen to be error prone and, consequently, when we apply post-digital thinking, new and old technologies, and the uncertainty of people, the creative potential is intensified. This underscores the view that post-digital error is a complex phenomenon. It can be encapsulated as error providing insight into that which is outside us, or directly apparent. Error in my work sets these ideas in motion, prompting a rethink of our own agency and the consequences of the fragility of human/nonhuman relationships.

Conceivably, error can be reductive. However, print's functionality has been expanded in this research from an analogue means of reproduction to something less linear, more uncertain and emergent. In *Enchiridion*, print alongside computational technologies begins to undermine and break down formal classifications. Under post-digital conditions, errors exist above and beyond digital or binary interpretations. My research rejects such divisions and boundaries, allowing error to operate across online and offline spaces, challenging ideas of what is material or immaterial. Hence, printed matter is able to be rethought in post-digital conditions as something that matters.

My research calls for a shift in the way we think about and discuss error and the printed object. In rejecting parameters such as time-space-place (and other linear constructs that persist in print discourses), error is repositioned as transversal, capable of moving between analogue and digital systems, between what is known and not known. This research thereby uncovers, reviews, and questions hierarchies; in its place new relationships and possibilities emerge which, unbounded by categorisation, favour the messy in-between spaces where creativity resides. Error in post-digital print opens up imaginative potential. This is one of the main arguments throughout my research, and is something that my projects have demonstrated by embracing the inherent misbehaviour of print technology and the uncertainty of post-

digital ideas, culture, and practices. In *Enchiridion*, it is error's latent ability to disrupt rational thought which demonstrates its potential and presents an opportunity to access an unforeseen field of possibilities.

## 8.2 Error exposes misadventures of thought

This research is built on the foundational claim that error exists under post-digital conditions beyond binary or digital understandings. The post-digital is defined in this research as a messy process; not a clean, informational one, and not following didactic programmatic logic. It is messy because it involves digital and analogue processes, as well as the unpredictability of people and other entities. These conditions are demonstrated in my project *Reading Enchiridion*, which exposes how, despite its grounding in the materiality of printmaking, post-digital print error's inherent messiness is as equally attuned to abstracted human understandings as to computational logic. The project, therefore, brings together common print errors with conceptual and theoretical ideas that emphasise the importance of *being human*, alongside the inherent problems of anthropocentrism.

*Reading Enchiridion* likewise reveals the slipperiness and unpredictability of (human) error, which is at odds with the relative predictability of computational

logic. In the spirit of the post-digital, the project juxtaposes human error with *glitch*, as The (stuttering) Reader articulates information like a temporal malfunctioning printer, hence accentuating the blurriness of human/machine differentiations.

Deleuze's phrase 'misadventures of thought' (1994, p. 148) serves as inspiration in defining a space which is comparable to erring or wandering, and redolent of not knowing. This sense of misadventure is prominent in the project *Reading Enchiridion* where error is observed as susceptible to going astray and is enmeshed with not just non-conscious thought, but also with technological and cultural imaginaries. Error here becomes positioned somewhere between *misbehaviour* and *misadventure*.

The low-tech print practice that is explored in *Reading Enchiridion* exposes some of the complexities of networked technologies, speaking to our progressively blurred online and offline existence. This stresses how my work has political implications for, and relationships with, wider digital culture, with reference to fake news and information sharing. Errant information in *Reading Enchiridion*, such as creating misleading content and disinformation in The Reader's instruction sets, also recounts issues of the political and social implications of disinformation and misinformation in digital cultures. The



emergence of deep fakes, conspiracy theories and political disenchantment has now become a part of the digital landscape and presents a shift in cultural attitudes to truth, bias, and certainty. By association, my work encourages us to feel at ease around error, inaccurate information, and uncertainty. Errors emphasise the subjectivity of information in online platforms such as TikTok, YouTube or, in the case of my projects, wikiHow. *Reading Enchiridion* calls attention to contentious online instructions which are neither right nor wrong. The Reader's errors conflict with dogmatic interpretations that are at odds with abstract or humanistic errors, and reinforce the necessity to go beyond binary distinctions: error is both *yes AND no*. It is my claim that errors break down and disrupt digital logic and rational thinking, and that this is in keeping with artistic research as a means of generating new knowledge.

In *Reading Enchiridion*, error challenges and disrupts digital logic – and a Western humanist tradition of rationality and reason – which does not place sufficient value on instinct, illogical or chance circumstances. My experimentation with error questions notions of success-making by disrupting the authority of wikiHow and knowledge systems more broadly. An implication of the project is that error can cast doubt on the assumed coupling of knowledge acquisition with technological progress. In contrast, (un-)learning is

not driven by motivations for rationality or solutionism, but rather by staying open to encounters with error.

The conception of error is recast as an uncertain and complex space of not knowing, unlearning, and renewal. Error grants access to unexplored territories and operates as a 'portal' to 'the unthinkable and the unimaginable' (as Voegelin puts it, 2019, p. 103). A shift from a known and logical perception of the world occurs to one that is less certain, and even unknowable. Pursuing the ambiguity of errant spaces, or places, contributes to a sense of not knowing and shows knowledge as prone to error. Error allows access to a complex network of vulnerable human and nonhuman relations not accessible by other means.

### **8.3 Error demonstrates a co-constituted form of agency**

Having spent considerable time working closely with old printers as part of my practice, I have been inspired in the project *[mis]Feeds* by the subtle characteristics of individual printers, each speaking of their own construction at a range of scales, while also elaborating on larger issues including the sustainability of printed matter and our relationship with technology. Exploring error in post-digital print, and its entanglement with systems and networks,

provides insights into larger matters which relate to the nonhuman and its ability to exhibit agency. An examination of the minutiae of post-digital print errors likewise contributes to a recognition of error's agency, whilst posing wider reaching questions about the agency of matter.

Error's agency is not fixed and is instead formed by as a series of intra-actions. This proposition may alter current conversations by identifying that the material structure of error is conceived not from just its own effects, but also the external influences of related things or beings. It thus advances print-based debates, by affirming the agency of error to exhibit its own form of materiality, beyond the corporeal, consisting of systems, encounters, and ideas. This conception adds leverage to my conceptualisation of error's agency: one that is lively and formed by its actions.

My set of projects reveal how print technologies, systems, and software communicate in online and offline spaces in unintelligible voices, and often with blurred boundaries. This indeterminate connective space is described in the research as cross-talk, where a series of actions interact and are translated across technologies, cultures, and systems. As the artist, I operate as part of the relational whole as a mediator of these complex interconnections. In *[mis]feeds*, error is dynamic and shifting between bodies – the human body, or

the plastic printer body, or bodies of knowledge – and conscious and nonconscious thought, printed forms, and systems. This fluidity is perceptible in the project where error operates between inner and outer thought, material and immaterial processes.

The projects also demonstrate how printers have potentiality beyond associations or common frames of reference, as they are pushed beyond their intended purpose, beyond functionality, or usability as accurate machines of reproduction. They are thus differentiated from our prior understanding or knowledge of them. Though investigating liveliness beyond obsolescence, the print errors are exposed as exceeding their status as inert objects. The printed errant matter in the projects persist beyond a carrier of meaning, and pervades a material agency that exceeds the human linguistic register. Wandering away from known paths, new unforeseen knowledge emerges which favours uncertainty, and the printer's itinerant errors provide access to the non-verbalised speech. This creates opportunity for cross-talk where diverse voices and new relations emerge.

#### 8.4 Contingency becomes the unbounded condition of error

Error-in-action is demonstrated in *[mis]Folding* in its condition of liveness, at the point of its becoming. The project acknowledges how error exhibits an agency that is indeterminate or, in other words, contingent. In its contingency, error stimulates a creative situation based on profoundly unsteady forces. The liveliness of error-in-action becomes a process that alters the relations between humans and nonhuman entities. Error can be seen to be part of a wider contingent and complex network of things and beings, ideas, cultures, and systems which co-exist in my projects.

In this research, error has been shown to be without limits. As a live and dynamic thing, at times its reach feels seemingly endless. Whilst error commonly requires correcting or conquering, in my practice this approach has been cast aside, as have attempts to subjugate the indeterminacy of error. In its place, contingency has emerged as an important factor in actuating error in the present. However, this is not carried out in the pursuit of accuracy and knowing, but rather in order to prepare a *contingency plan* for error and non-knowing. The contingency plan in my research practice can be perceived as the initial idea, or project outline, which scopes out the possibility of error and gains access to the indeterminate and that which has capacity to activate error.

For these reasons, I urge printmakers to be open to the contingencies that error affords and its potential to provide access to new artistic insights.

## 8.5 Openings

The implication of paying close attention to error through the context of post-digital print is that it effects current printmaking discourses and practices by creating greater distance from a historical focus on accurate reproduction. As error persists as a common issue amongst printmakers, concentrating on error under post-digital conditions shifts debates away from centring on traditional interpretations of error – to centring on more entangled relations with error, machines, and nonhuman agency. My research propels this change of emphasis by setting out as its foundation that relationality concerns, at least in part, how human and nonhuman entities are interconnected in the materiality of a print-based practice. My diagrams and projects acknowledge that through a relational and decentralised structure error cannot exist in isolation from its material conditions.

Because of these findings, my practice provides openings for new research driven by my conceptions of *errors-in-actio* and *cross-talk*, which create opportunities for future work on error *as event*. The research conceptualises

errors in temporal, eventful terms, which in turn generates exciting new avenues for further exploration of performativity. The series of projects that make up this submission involve performance – both in the video work, in the folding work, and in a wider sense in the performance or misbehaviour of the printing machines – yet fresh ideas around *error as event* point more directly to the temporality of errors and stress their relationship to performance. These ideas will take my subsequent work in new directions that involve eventuality, or contingency, of errors' agency and the performativity of errors-in-action.

My research also points me towards ideas of labour, specifically the labour of machines, and their exhaustion. Although much of the work has been devolved to machines, my practice retains a strong bias towards laborious creative processes. The projects and this thesis speak to a politics of labour, by exposing error's dependence on relations, both social and machinic. Whilst discussed in terms of the human and nonhuman network of my print-based practice, this opens additional questions on the politics of artistic labour in the digital era and questions of automation.

Future research projects will be undertaken at The Centre for Fine Print Research at the University of the West of England and will take this research forward by advancing these ideas related to labour, performance, and

exhaustion. Projects will concentrate on the *copy*, taking the form of a cultural reimagining of the *copy shop* (found on many high streets offering printing and photocopying services, pre-digital printing) as a performative space.

Attentiveness to the collaborative labour of machines encourages me to rethink the position of autonomy and normative ways of working, which in recent times has been difficult to maintain owing to the evolving nature of our relationship with semi-autonomous systems – albeit technological, institutional, or environmental – and changing modes of artistic production. Further examining the relationality of error, coupled with these new openings – of labour, performance, and exhaustion – creates space for the collective imagination. Future work will explore these concerns, further dismantling ideas of the individual creative subject and object-based practices, advocating error as a catalyst for the collective imagination – as a disruptive and generative force. As such, any perceived errors that remain in this thesis, are generative of new ideas yet to come.



## Afterword

How might we describe error that is emergent and only capable of existing through relations, if not through the things and printed matter it interacts with?

This question remains open so that it can stress the significance of my artistic practice for this research. In the same way that the User Guide foregrounds the weight of my practice at the beginning of this thesis, it seems appropriate to conclude with a final comment on my projects, thus bookending the written research with practice.

The importance of practice-led research was demonstrated during the last exhibition of my research in The Arts Institute at the University of Plymouth in April 2021 (see User Guide). Although the exhibition was not open to the public due to Covid-19 lockdown restrictions, it nevertheless created a quite different experience than expected. The installation became one of curating *lines of thought*, rather than considering more centrally how my projects would be met by an audience. That is to say, it transformed into a larger-scale experiment, a multi-faceted and cohesive diagramming activity, uncovering a network of entangled ideas and errant encounters.

This was beyond the reach of my initial intention for the installation, which was

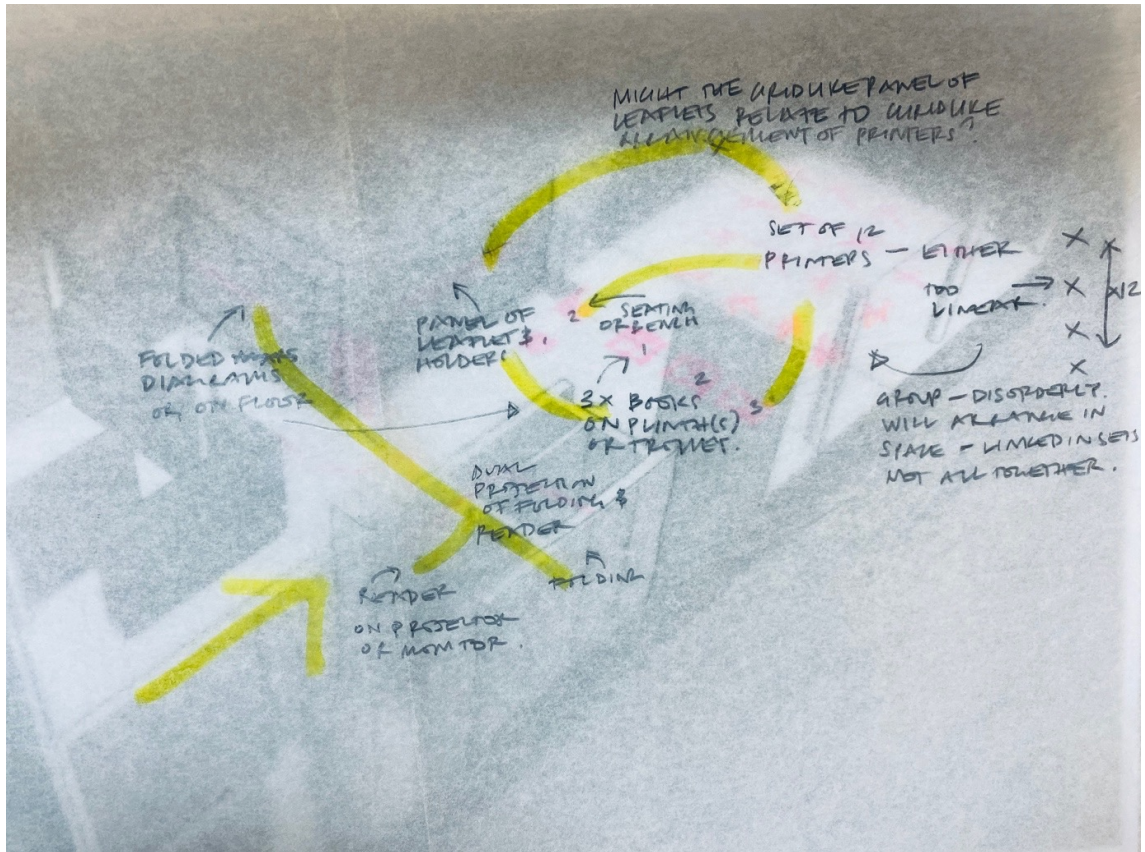

Figure 72: Detail of a diagram exploring how the exhibition space became a diagrammatic space, a flow of ideas and lines of thought (Rosser, 2021).

intended to be a means of producing documentation for the User Guide.

Instead, the system of ideas and projects were actualised as a dynamic and lively diagrammatic space (Fig. 72) in which the agency of error was active.

Exhibiting my work in this way reiterated some of the core concepts present in the research, in particular ideas around the enmeshed network of errors, printed matter, and the development of my thinking. The relations were reinforced by exploring the links between elements and building meaning

through a series of diagrams, as well as responding to error as it unfolded live in the gallery.

The process of realising the physical show revitalised the relationality and liveness of error-in-action. The act of thinking about and physically installing the works in a space likewise fortified the synthesis of ideas at play in my artistic practice, and also exposed some of the complexities post-digital thinking affords. It strengthened my argument about how error produces contingency and depends on its network of relations in order for it to be actualised, or experienced – like a weed squeezing through a crack in the wall, or as a bug disrupting a perfect digital system. Without the practice *error* remains a somewhat generic term without structure, shape or body. It is through errors' dynamic intra-actions that meaning is acquired: an overprinting error on the dot matrix printed feed; an errant stumbling reading of the folding instructions; or an erring and uncertain fold in the diagram as it breaks down.

This coming together of my research practice on this occasion helps to exemplify how error cannot be understood in and of itself. On the contrary, it is defined through its relations in space-time at a range of scales. It is not self-evident or pre-defined and cannot be assumed a priori. I uncover error's co-constituted agency in combination with the empirical observation of my

practice, alongside the series of diagrams and theoretical ideas explored in the written thesis.

Error's agency is evidently contingent on its relations which unfold in space and time. The projects present a set of situations which do not rely on history or a clear set of intentions, nor are they knowable in advance. They do not require a solution or fixing or a set conclusion as such. Rather, my practice-led research has prioritised error's emergent and generative potential to reveal its agency in and through the practice of post-digital print. Error's agency is not what an error is, it is what an error does. This forcefulness, this gap, is error-in-action.

## List of Sources

- Abramović, M. (2010) *The Artist Is Present* [Performance]. Moma Learning, New York. Available at: [https://www.moma.org/learn/moma\\_learning/marina-abramovic-marina-abramovic-the-artist-is-present-2010/](https://www.moma.org/learn/moma_learning/marina-abramovic-marina-abramovic-the-artist-is-present-2010/) (Accessed: 12 December 2021).
- Ambrožič, M. (2019) 'Diagramming Art's Institutional Global Playground', *Diagramming Research Seminar and Workshop*. University of Plymouth, Plymouth, 13 May.
- Andrews, I. (2002) *Post-digital Aesthetics and the Return to Modernism*. Available at: <https://ian-andrews.org/texts/postdig.pdf> (Accessed: 26 September 2021).
- Antin, X. (2010a) *Just in Time, or a Short History of Production*. London: Self Published.
- Antin, X. (2010b) *Printing at Home*. London: Ditto Press.
- Antin, X. (2016) *The Eternal Network*. Bristol: Spike Island.
- Augustijnen, S. (2001–2003) *Johan and Francois* [Film]. Available at: <https://augusteorts.be/catalogue/27/johan> (Accessed: 12 August 2020).
- Balfour, B. (2007) *100 Things That Make Me Happy* [Sculptures]. Available at: <http://www.barbarabalfour.ca/plan-b-and-100-things.html> (Accessed: 21 March 2021).

- Bandura, A. and Adams, N. E. (1977) 'Analysis of Self-efficacy Theory of Behavioral Change'. *Cognitive Therapy and Research*, 1, pp. 287-310.
- Barad, K. (1996) 'Meeting the Universe Halfway: Realism and Social Constructivism without Contradiction', in Nelson, L. H. and Nelson, J. (eds.) *Feminism, Science, and the Philosophy of Science*. Dordrecht: Springer Netherlands, 256, pp. 161–194.
- Barad, K. (2003) 'Posthumanist Performativity: Toward an Understanding of How Matter Comes to Matter', *Signs: Journal of Women in Culture and Society*, 28, pp. 801–831.
- Barad, K. (2007) *Meeting the Universe Halfway: Quantum Physics and the Entanglement of Matter and Meaning*. Durham, NC: Duke University Press.
- Barham, Anna (2013) *Triple Noun Stratagem*, [Drawing]. Available at: <https://drawingroom.org.uk/directory/artists/Anna-Barham> (Accessed: 17 September 2020).
- Barker, T. (2007) 'Error, the Unforeseen, and the Emergent: The Error and Interactive Media Art', *M/C Journal* [Online], 10. Available: <https://journal.media-culture.org.au/index.php/mcjournal/article/view/2705> (Accessed 21 May 2020).

- Bates, D. (1996) 'The Epistemology of Error in Late Enlightenment France', *Eighteenth-Century Studies*, 29, pp. 307–327.
- Bates, D. (2002) *Enlightenment Aberrations: Error and Revolution in France*. New York: Cornell University Press.
- Beech, D. (2018) 'Art and Labour' [Lecture], *Practice-led Research and the REF*. University of Plymouth, Plymouth, 4 July 2018.
- Bennett, J. (2004) 'The Force of Things: Steps toward an Ecology of Matter', *Political Theory*, 32, pp. 347–372.
- Bennett, J. (2010a) *Vibrant Matter: A Political Ecology of Things*. Durham, NC: Duke University Press.
- Bennett, J. (2010b) 'A Vitalist Stopover on the way to a New Materialism', in Coole, D. H. and Frost, S. (eds.) *New Materialisms: Ontology, Agency, and Politics*. Durham, NC: Duke University Press, pp. 47–69.
- Bennett, J. (2011) 'Artistry and Agency in a World of Vibrant Matter'. *The New School*, 13 September. New York: Vera List Center for Art and Politics. Available at: <https://www.youtube.com/watch?v=q607Ni23QjA> (Accessed: 26 November 2020).
- Berry, D. (2010) *As We May Think* [Diagram], in Lewandowska, M. and Ptak, L. (2013) *Undoing Property?*. Cambridge, MA: MIT Press, pp. 14–15.
- Berry, D. (2015b) 'The Digital Iceberg', *Postdigital Aesthetics: Art, Computation and Design*, p. 47. London: Palgrave Macmillan.

- Berry, D. (2014) 'On Latour's Notion of the Digital', in *Stunlaw: Philosophy and Critique for a Digital Age*. Available at:  
<http://stunlaw.blogspot.com/2014/08/on-latours-notion-of-digital.html>  
(Accessed: 7 May 2020).
- Berry, D. and Dieter, M. (2015) *Postdigital Aesthetics: Art, Computation and Design*. London: Palgrave Macmillan.
- Berry, D. M. (2017) 'The Post-Archival Constellation: The Archive Under the Technical Conditions of Computational Media', in Blom, I., Lundemo, T. and Røssaak, E. (eds.) *Memory in Motion*. Amsterdam: Amsterdam University Press, pp. 103–126.
- Berry, D. M. and Galloway, A. R. (2015) 'A Network is a Network is a Network: Reflections on the Computational and the Societies of Control', *Theory, Culture and Society*, 33, pp. 151–172.
- Beuys, J. (1972) *Four Blackboards* [Performance]. Tate Modern, London.
- Biehl, J. and Locke, P. (2010) 'Deleuze and the Anthropology of Becoming', *Current Anthropology*, 51, pp. 317–351.
- Bigland, G. (2018) *AAA to AZZ*. Available at: <https://www.guybigland.com/>  
(Accessed: 10 July 2021).
- Bigland, G. (2019) *AA to ZZ*. Available at: <https://www.guybigland.com/>  
(Accessed: 10 July 2021).



- Bishop, R., Gansing, K., Parikka, J., Wilk, E., Winchester School of Art and Transmediale, E. V. (2016) *Across & Beyond: A Transmediale Reader on Post-digital Practices, Concepts, and Institutions*. Berlin: Sternberg Press.
- Bogue, R. (2010) 'Minoritarian + Literature', in Parr, A. (ed.) *Deleuze dictionary*. 2nd edn. Edinburgh: Edinburgh University Press, pp. 170–171.
- Bonadies Creative Inc. (2017) *LetterMpress* (1.5.2) [Mobile app]. (Accessed: 9 December 2021).
- Boundas, C. (2010) 'Intencity', in Parr, A. (ed.) *Deleuze dictionary*. 2nd edn. Edinburgh: Edinburgh University Press, pp. 131–135.
- Bristow, T. M. (2018) *Post African Futures: Decoloniality and Actional Methodologies in Art and Cultural Practices in African Cultures of Technology*. Plymouth: University of Plymouth Press.
- Bryant, L. R. (2017) 'Deleuze contra Error: Other Misadventures of Thought', *Larval Subjects*. Available at: <https://larvalsubjects.wordpress.com/2017/04/03/deleuze-contra-error-other-misadventures-of-thought/> (Accessed: 19 September 2021).
- Burks, A. W. (1949). 'Icon, Index, and Symbol', *Philosophy and Phenomenological Research*, 9, pp. 673–689.
- Callanan, M. J. (2016) *Each and Every Command*. Baltic39. Available at: <http://greyisgood.eu/eachevery> (Accessed: 29 December 2018).

- Caoduro, E. (2014) 'Photo Filter Apps: Understanding Analogue Nostalgia in the New Media Ecology', *Networking Knowledge: Journal of the MeCCSA Postgraduate Network*, 7, pp. 67–82.
- Carboni, A. (2016) *Being Here, in What no Longer Be*. Available: <https://progressivearchive.wordpress.com/> (Accessed: 29 December 2018).
- Cascone, K. (2000) 'The Aesthetics of Failure: "Post-Digital" Tendencies in Contemporary Computer Music', *Computer Music Journal*, 24, pp. 12–18.
- Chambers Twentieth Century Dictionary (1972) In Macdonald, A. M. (ed.). United Kingdom: Chambers.
- Charlton, J. (2014) 'On Remembering a Post-Digital Future', *A Peer-Reviewed Journal About*, 3, pp. 145-155.
- Chernick, K. (2020) 'Art Forger Han van Meegeren Fooled the World Into Believing His Fake Vermeers. A New Film Unpacks His Bag of Tricks', *Artnet*. Available at: <https://news.artnet.com/art-world/the-last-vermeer-1922335> (Accessed: 3 April 2021).
- Clarke, A. (2012) 'de-leb', *Banner Repeater*. Available at: <https://www.bannerrepeater.org/de-leb-sci-fi-blockchain> (Accessed: 14 December 2021).

- Cocker, E. (2016a) 'Performing Thinking in Action: The Meletē of Live Coding', *International Journal of Performance Arts and Digital Media*, 12, pp. 102–116.
- Cocker, E. (2016b) *The Yes of the No*. Sheffield: Site Gallery.
- Cole, D. and Perner-Wilson, H. (2019) 'Getting Lost and Unlearning Certainty: Material Encounters in an Electronic Craft Practice', In: Bogers, L. and Chiappin, L. (eds.) *The Critical Makers Reader: (un) Learning Technology*. Amsterdam: Institute of Network Cultures, Amsterdam University of Applied Sciences, pp. 107–126.
- Coleman, F. J. (2018) 'Agency'. *New Materialism: How Matter Comes to Matter*. Available at: <https://newmaterialism.eu/almanac/a/agency.html> (Accessed: 30 December 2020).
- Coles, T. (2010) 'Five and Eight Hole Perforated Tapes' Accessed at: <https://commons.wikimedia.org/wiki/File:PaperTapes-5and8Hole.jpg#/media/File:PaperTapes-5and8Hole.jpg> (Accessed: 11 August 2019).
- Cole, D. H. and Frost, S. (2010) *New Materialisms: Ontology, Agency, and Politics*. Durham, NC: Duke University Press.
- Cox, G. (2014) 'Prehistories of the Post-Digital: Or, Some Old Problems with Post-Anything', *A Peer-Reviewed Journal About*, 3, pp. 71–74.

- Cramer, F. (2014). What Is 'Post-digital'? In: Berry, D. M. & Dieter, M. (eds.) *Postdigital Aesthetics: Art, Computation and Design*. London: Palgrave Macmillan. pp. 12–26.
- Cramer F. (2014) 'You're not a real hipster – until you take your typewriter to the park (2013)', What Is 'Post-Digital'?, p. 11.  
<https://doi.org/10.7146/aprja.v3i1.116068>.
- De Landa, M. (2000) 'Deleuze, Diagrams, and the Genesis of Form', *Amerikastudien/American Studies*, pp. 33–41.
- Deleuze, G. (1978). 'Kant: Synthesis and Time' [Recorded Seminar]. *The Deleuze Seminars. 28 March. Available at:*  
<https://deleuze.cla.purdue.edu/seminars/kant-synthesis-and-time/lecture-02> (Accessed: 19 March 2022).
- Deleuze, G. (1994) *Difference and Repetition*. London: Athlone Press.
- Deleuze, G. (1995) *Negotiations, 1972–1990*. New York: Columbia University Press.
- Deleuze, G. (2004) *Difference and Repetition*. Translated from French by P. Patton. London: Bloomsbury Academic.
- Deleuze, G. and Guattari, F. (1987) *A Thousand Plateaus: Capitalism and Schizophrenia*. Minneapolis: University of Minnesota Press.
- Deleuze, G. and Hand, S. (1988) *Foucault*. London: Athlone Press.

- Deleuze, G. and Parnet, C. (2002) *Dialogues II*. New York: Columbia University Press.
- Deleuze, G., Conley, T. and Von Leibniz, G. W. F. (1993). *The Fold: Leibniz and the Baroque*. Minneapolis: University of Minnesota Press.
- Deprez, J. (2012–2013) *Staring at the Wall: The Art of Boredom* [Exhibition]. John M. O'Quinn Gallery: Lawndale Art Center, Houston.
- Diamond Sūtra* (868) [Woodblock-printed scroll]. British Library, London.  
Available at: <https://www.bl.uk/collection-items/the-diamond-sutra>  
(Accessed: 21 September 2021).
- Dillon, B. (2014) *Objects in this Mirror: Essays*. Berlin: Sternberg Press.
- Eco, U. (1989) *The Open Work*. Cambridge, MA: Harvard University Press.
- Fabricius, J., Jørgensen, Å. E. and Rasmussen, J. (2018) *Pist Protta, No. 82*. Copenhagen: Space Poetry.
- Fazi, M. B. (2016) 'Incomputable Aesthetics: Open Axioms of Contingency', *Computational Culture*, 5. Available at:  
<http://computationalculture.net/incomputable-aesthetics-open-axioms-of-contingency>. (Accessed: 19 July 2019).
- Fazi, M. B. (2018) *Contingent Computation: Abstraction, Experience, and Indeterminacy in Computational Aesthetics*. 1st edn. London: Rowman and Littlefield International.

- Fazi, M. B. (2019) 'Digital Aesthetics: The Discrete and the Continuous',  
*Theory, Culture and Society*, 36, 3–26.
- Fisher, E. and Fortnum, R. (2013) *On Not Knowing: How Artists Think*. London:  
Black Dog Publishing.
- Floridi, L. (2009) 'Against Digital Ontology', *Synthese*, 168, pp. 151–178.
- Fortnum, R. (2009) *Introduction* [Speech]. Symposium: On Not Knowing: How  
Artists Think, Kettle's Yard, University of Cambridge. 29 June.
- Fox, D. (2020) 'Sophisticated Idiots'. Review of *Contingent Computation:  
Abstraction, Experience, and Indeterminacy in Computational  
Aesthetics*, by Fazi, M. Review31. Available at:  
<http://review31.co.uk/article/view/616/sophisticated-idiots> (Accessed:  
20 September 2021).
- Galloway, A. R. and Thacker, E. (2007) *The Exploit : A Theory of Networks*.  
Minneapolis: University of Minnesota Press.
- Geary, A. and Catanese, P. (2012) *Post-Digital Printmaking: CNC, Traditional  
and Hybrid Techniques*. London: A&C Black.
- Gell, A. (1998) *Art and Agency: An Anthropological Theory*. Oxford: Clarendon  
Press.
- Goble, E. (2017) 'Beyond Human Subjectivity and Back to the Things  
Themselves: Jane Bennett's Vibrant Matter', *Phenomenology and  
Practice*, 11, pp. 70–78.

Goodman, N. (1968) *Languages of Art: An Approach to a Theory of Symbols*.

Indianapolis: Bobbs-Merrill.

Guattari, F., Sheed, R. and Cooper, D. (1984) *Molecular Revolution: Psychiatry*

*and Politics*. London: Penguin.

Haacke, H. (1969/2008) *News* [Art Installation]. San Francisco Museum of

Modern Art, San Francisco. Available at:

<https://www.sfmoma.org/artwork/2008.232/> (Accessed: 26 August 2019).

Hall, T. and Froderberg, A. (1970) *Carl Friedrich Gauss: A Biography*.

Cambridge, MA: MIT Press.

Harman, G. (2009) *Prince of Networks: Bruno Latour and Metaphysics*.

Melbourne: re.press.

Harman, G. (2011a) 'The Road to Objects', *Continent*, 3.1, 171–179.

Harman, G. (2011b) 'Autonomous objects', *New Formations*, 71, 125–130.

Available at:

[https://www.academia.edu/789796/Deborah\\_Staines\\_reviews\\_Judith\\_Butlers\\_Frames\\_of\\_War](https://www.academia.edu/789796/Deborah_Staines_reviews_Judith_Butlers_Frames_of_War) (Accessed: 20 Feb 2022).

Hayles, K. (1999) *How we Became Posthuman: Virtual Bodies in Cybernetics,*

*Literature, and Informatics*. Chicago: University of Chicago Press.

Hayles, K. (2017) *Unthought: the Power of the Cognitive Nonconscious*.

Chicago: University of Chicago Press.

- Higgins, C. (2007) 'Gilbert and George put free artwork on internet', *The Guardian*, 8 May. Available at:  
<https://www.theguardian.com/uk/2007/may/08/art.artnews> (Accessed: 12 December 2021).
- Jones, A. (2003) *The Feminism and Visual Culture Reader*. London: Routledge.
- Jones, J. (2019) *The Oldest Book Printed with Movable Type is Not The Gutenberg Bible: Jikji, a Collection of Korean Buddhist Teachings, Predated It By 78 Years and It's Now Digitized Online*. Available at:  
<https://www.openculture.com/2019/07/jikji.html> (Accessed: 12 December 2021).
- Jones, R. (2013) 'On the Value of Not Knowing: Wonder, Beginning Again and Letting Be', in Fisher, E. and Fortnum, R. (eds.) *On Not Knowing: How Artists Think*. London: Black Dog Publishing, pp. 16–31.
- Joyce, M. (1995) *Of Two Minds: Hypertext Pedagogy and Poetics*. Ann Arbor: University of Michigan Press.
- Kelley, M. (2014) 'Mike Kelley God, Family, Fun, and Friends: Mike Kelley in Conversation with John C. Welchman', in Welchman, J. C. (ed.) *Learning to Teach Art and Design in the Secondary School: A Companion to School Experience*. Abingdon: Taylor and Francis.



- Kenning, D. (2011) *Metallurgy Of The Subject*. Available at:  
<http://www.deankenning.com/Metallurgy.html> (Accessed: 29 December 2018).
- Kenning, D. (2020). *Aesthetical-Rational-Logical Diagram* [Performance].  
Available at: <http://flattimeho.org.uk/projects/fttho-news/delta-d-research-placement/> (Accessed: 3 October 2021).
- Kent, C. (1965) *Enriched Bread* [Screenprint]. Available at:  
<https://www.sfmoma.org/artwork/2008.224/> (Accessed: 15 June 2020).
- Kholeif, O. and Whitechapel Art Gallery (2016) *Electronic Superhighway: From Experiments in Art and Technology to Art After the Internet*. London: Whitechapel Gallery.
- Kittler, F. A. (1985) *Discourse Networks 1800/1900*. Stanford: Stanford University Press.
- Kodak I Nexfinity Digital Press (2022) Available at:  
<https://www.kodak.com/en/print/product/digital/nexfinity/features#details> (Accessed: 13th February 2022).
- Kosuth, J. (1986) *Zero & Not* [Installation] Pierogi Gallery, New York. Available at: [https://www.under-erasure.com/artists-writers/joseph\\_kosuth/](https://www.under-erasure.com/artists-writers/joseph_kosuth/) (Accessed: 11 May 2020).
- Krauss, R. (1979) 'Sculpture in the Expanded Field', *October*, 8, pp. 31–44.

- Krauss, R. (1985) *The Originality of the Avant-Garde and Other Modernist Myths*. Cambridge, MA: MIT Press.
- Lacan, J., Fink, B., Fink, H. and Grigg, R. (2006) *Ecrits: The First Complete Edition in English*. New York: W. W. Norton.
- Laidler, P. (2011) 'Human automation', *Printmaking Today*, 20, p. 28.
- Laidler, P. (2016) *Looking Through the Eyes of Machines as Humans*. Bristol: University of the West of England.
- Lambert, S. (1983) *Printmaking*. London: H.M. Stationery Office.
- Latour, B. (1993) *We Have Never Been Modern*. Translated from French by C. Porter. Cambridge, Massachusetts: Harvard University Press.
- Latour, B. (1996) 'On Actor–Network Theory: A Few Clarifications', *Soziale Welt*, 47, pp. 369–381.
- Latour, B. (1999) 'On Recalling Ant', *The Sociological Review*, 47, pp. 15–25.
- Latour, B. (2002) 'What is Iconoclasm? Or is There a World Beyond the Image Wars', Latour, B. & Weibel, P. (eds.) *Iconoclasm: Beyond the Image Wars in Science, Religion, and Art*. ZKM and MIT Press. pp. 14–37.
- Latour, B. (2005) *Reassembling the Social: An Introduction to Actor–Network-Theory*. Oxford: Oxford University Press.
- Latour, B. (2012) 'Love Your Monsters, Why We Must Care for Our Technologies As We Do Our Children', *Breakthrough Journal*, 2.

Available at: <https://thebreakthrough.org/journal/issue-2/love-your-monsters> (Accessed: 16 April 2020).

Latour, B. (2014) *Digital Humanities: Rematerializing Humanities Thanks to Digital Traces*. Lausanne, Switzerland, 7 July – 12 July 2014.

Latour, B. (2020) 'Bruno Latour: This is a Global Catastrophe that has Come from Within'. Interview with B. Latour. Interviewed by J. Watts for *The Guardian*, 6 June. Available at: <https://www.theguardian.com/world/2020/jun/06/bruno-latour-coronavirus-gaia-hypothesis-climate-crisis> (Accessed: 25 July 2020).

Law, J. (2007) *Actor Network Theory and Material Semiotics*. Available at: <http://www.heterogeneities.net/publications/Law2007ANTandMaterialSemiotics.pdf> (Accessed: 20 September 2021).

Le Feuvre, L. (2010) *Failure*. London: Whitechapel Gallery.

Lefterov, P. (2014) *Error 520* [Screenprint]. Available at: <https://www.saatchiart.com/art/Printmaking-Error-520/82547/2165658/view> (Accessed: 12 May 2020).

Lewandowska, M. and Ptak, L. (2013) *Undoing Property?*. Cambridge, MA: MIT Press.

Liversidge, P (2008-2009) *Jupiter Proposals* [Installation]. Jupiter Artland, Edinburgh. Available at: <https://www.jupiterartland.org/art/peter-liversidge-jupiter-proposals/> (Accessed: 8 January 2023).

- Lovink, G. and Schultz, P. (1997) 'There is No Information, Only Transformation'. Interview with B. Latour. Interviewed by G. Lovink and P. Schultz for *Hybrid Workspace, Documenta X*, Kassel 16 August. Available at: <https://www.nettime.org/Lists-Archives/nettime-l-9709/msg00006.html> (Accessed: 2 May 2020).
- Ludovico, A. (2012) *Post-Digital Print: The Mutation of Publishing Since 1894*. Eindhoven: Onomatopee.
- Manhole Inc. (2019) *Huji Cam (2.3) [Mobile app]*. (Accessed: 19 January 2022).
- Manovich, L. (2001) *The Language of New Media*. Cambridge, MA: MIT Press.
- Marcuse, H. (1941) 'Some Social Implications of Modern Technology', *Zeitschrift für Sozialforschung*, 9(3), pp. 414–439.
- Marcuse, H. (1964) *One Dimensional Man: Studies in the Ideology of Advanced Industrial Society*. Boston: Beacon Press.
- Max, D. T. (2014) 'Hans Ulrich Obrist and Do It Profiled in the New Yorker'. Interview with H. U. Obrist. Interviewed by D. T. Max for *The New Yorker*, 2 December, New York. Available at: <https://curatorsintl.org/records/2547-hans-ulrich-obrist-and-do-it-profiled-in-the-new-yorker> (Accessed: 8 January 2023).
- Mcintyre, M. M. (2015) *Relational Agency, Networked Technology, and the Social Media Aftermath of the Boston Marathon Bombing*. PhD Thesis. University of South Florida.

Mcluhan, E. (2011) *Marshall McLuhan*. Available at:

<https://www.marshallmcluhan.com/common-questions> (Accessed: 13 September 2020).

Mcluhan, M. (1964) *Understanding Media: The Extensions of Man*. New York: McGraw-Hill.

Menkman, R. (2009–2010) *Vernacular of File Formats* [Digital prints]. Available at: <https://beyondresolution.info/A-Vernacular-of-File-Formats> (Accessed: 19 February 2021).

Menkman, R. (2011) *The Glitch Moment(um)*. Amsterdam: Institute of Network Cultures.

*Mistakes* (2017) [Exhibition]. Real Room at Real Art Ways: Courant Gallery, New York. 24 July 2017–16 September 2017.

Mitchell, D. (2019) *Post Hoc*. Available at:

<https://www.danemitchell.co.nz/copy-of-tuning> (Accessed: 3 June 2021).

Moradi, I. (2004) *Glitch Aesthetics*. BA Dissertation. University of Huddersfield.

Mullarkey, J. (2011) 'Where, or When, is the Diagrammatic?' [Lecture] Project Space Talks on the Diagram. Banner Repeater, London. 18 July 2012.

Negroponte, N. (1995) *Being Digital*. London: Hodder & Stoughton.

Netz, R. (2003) *The Shaping of Deduction in Greek Mathematics: A Study in Cognitive History*. Cambridge: Cambridge University Press.

*Newspaper Extinction Timeline* (2011) [Illustration], in Ludovico, A. (2012) *Post-Digital Print: The Mutation of Publishing Since 1894*. Eindhoven: Onomatopée, p. 6.

Nunes, M. (2011) *Error: Glitch, Noise, and Jam in New Media Cultures*. London: Bloomsbury Academic.

Obrist, H. U. (1993 in progress) *Do It* [Online artwork]. Available at: <https://curatorsintl.org/exhibitions/18072-do-it-2013> (Accessed: 8 January 2023).

Ono, Y. (1964) *Grapefruit* [Artist's Book]. Available at: [https://monoskop.org/images/archive/6/64/20190320203953%21Ono\\_Yoko\\_Grapefruit\\_A\\_Book\\_of\\_Instructions\\_and\\_Drawings\\_2000.pdf](https://monoskop.org/images/archive/6/64/20190320203953%21Ono_Yoko_Grapefruit_A_Book_of_Instructions_and_Drawings_2000.pdf) (Accessed: 8 January 2023).

O'Sullivan, S. (2016) 'On the Diagram (and a Practice of Diagrammatics)', in: Schneider, K. & Yasar, B. (eds.) *Situational Diagram*. New York: Dominique Lévy, pp. 13–25.

Paik, J. (2017) *Nam June Paik's Distortions*. Available at: <http://lossyculture.altervista.org/nam-june-paik-distortions/> (Accessed: 1 April 2020).

Parikka, J. (2012) *What is Media Archaeology?*. Hoboken: Wiley.

Parnow, J. and Heinicker, P. (2020) *Stones that calculate*. Available at: <https://stones.computer/> (Accessed: 27 November 2020).

- Parr, A. (2010) 'Becoming + Performance Art' in *Deleuze Dictionary Revised Edition*. Edinburgh: Edinburgh University Press.
- Pearl, A. J. (2018) *Breakdown: Mechanical Dysfunction and Anthropomorphism*. Manchester: Manchester Metropolitan University.
- Peirce, C. S., Peirce, C. S., Hartshorne, C. and Weiss, P. (1933) *Collected Papers of Charles Sanders Peirce, Volumes III and IV: Exact Logic (Published Papers) and the Simplest Mathematics*. Cambridge, MA: Harvard University Press.
- Pettersson, J. (2015) *Printmaking in the Expanded Field*. Norway: Oslo National Academy of the Arts.
- Phillips, B. (2011) *A Benedictionary*. United Kingdom: DIV Books Production with Bellevuepress.
- Poskovic, E. (2017) *Dream – Pletikosa (Hagar in the Wilderness)* [Woodcut]. Available at: <https://endiposkovic.com/section/493502-Dream.html> (Accessed: 8 January 2023).
- 'Postdigital', in Wikipedia. Available at: <https://en.wikipedia.org/w/index.php?title=Postdigital&oldid=1058314348> (Accessed: 20 December 2021).
- Prensky, M. (2001) 'Digital Natives, Digital Immigrants Part 1', *On the Horizon*, 9, pp. 1–6.

- Prior, A. (2015) *Mediality is Noise –The Onto-Epistemology of Noise, Media Archaeology and Post-Digital Aesthetics*. PhD thesis. University of Aarhus, Aarhus, Denmark.
- Raczek-Karcz, M. A. (2017) 'Perfection and Glitch: The Influence of Digital Thinking on Polish Contemporary Printmaking', *Post-digital printmaking. Redefinition of print*. The Eugeniusz Geppert Academy of Art and Design in Wrocław, Poland. 26 November–12 December.
- Reality Errors* (2020–2021) [Exhibition]. Nam June Paik Art Center Gallery 2, Yongin-si South Korea. 24 September 2020–31 January 2021.
- Rogoff, I. (2008) 'Turning', *e-flux Journal*, 00, November 2008. Available at: <https://www.e-flux.com/journal/00/68470/turning/> (Accessed: 9 July 2020).
- Rosser, L. (2015) *No One Knows Where I Am* [Slide]. Available at: <https://laurarosser.com/works/> (Accessed: 20 January 2021).
- Rosser, L. (2015) *We Aint all Middle Class Bohemians* [hand cut woodcut]. Available at: <https://laurarosser.com/works/> (Accessed: 20 January 2021).
- Rosser, L. (2017) *Auto-Incorrect* [Installation]. Available at: <https://laurarosser.com/works/> (Accessed: 20 January 2021).
- Rosser, L. (2018) *A Machine Dialogue* [Diagram]. Available at: <https://laurarosser.com/works/> (Accessed: 20 January 2021).



- Rosser, L. (2018) *Agency of Error* [Performance]. Academy of Fine Arts, Katowice. Available at: <https://laurarosser.com/works/> (Accessed: 20 January 2021).
- Rosser, L. (2018) *Error* [Diagram]. StefArt Gallery, Tychy. Available at: <https://laurarosser.com/works/> (Accessed: 20 January 2021).
- Rosser, L. (2018) *Topology of Error* [Diagram]. Available at: <https://laurarosser.com/works/> (Accessed: 20 January 2021).
- Rosser, L. (2018) *Untitled Experiment* [Laser cut wood print].
- Rosser, L. (2019) *Reading Enchiridion* [Photograph].
- Rosser, L. (2018) *[mis]Folding* [Photograph]. Neo Print Studios, Bolton.
- Rosser, L. (2018) *[mis]Folding* [Performance]. Bolton University, Bolton.
- Rosser, L. (2018) *Enchiridion* [Installation]. University of Plymouth (Viewed: 7 December).
- Rosser, L. (2019) *Enchiridion: Machine Washing Your Ligature* [Laser print].
- Rosser, L. (2019) *How to (un)Fold Paper* [Script extract].
- Rosser, L. (2019) *[mis]Feeds #1* [Installation]. Kronika Centre for Contemporary Art, Bytom. (Viewed: 7 December 2019–24 January 2020).
- Rosser, L. (2021) *Enchiridion: Unlearning Space* [Installation]. Arts Institute, University of Plymouth (Viewed: 13–16 April).
- Rosser, L. (2021) *[mis]Feeds #3* [Installation]. Arts Institute, University of Plymouth (Viewed: 13–16 April).

Rosser, L. (2021) *[mis]Folding* [Installation]. Arts Institute, University of Plymouth  
(Viewed: 13–16 April).

Rosser, L (2022) 'Error as a Site of Breakdown and Renewal: Can Social Media be Used to Promote a Societies New Mode of Living, Labour and Community?', in P. Mendrek and M. Newth (eds.) *Parallax 2018–2021*. ASP: Katowice, London, Plymouth, Gothenburg, pp. 136–157.

Route 66 (2019) [Screenshot]. Available at:  
<https://www.misterretro.com/filters/permanent-press> (Accessed: 11 January 2019).

Russell, L. (2013) *Elsewhere, After the Flood: Glitch Feminism and the Genesis of Glitch Body Politic*. Available at:  
<https://rhizome.org/editorial/2013/mar/12/glitch-body-politic/>  
(Accessed: 19 September 2021).

Sanzo, K. (2018) *New Materialism(s)*. Available at:  
<https://criticalposthumanism.net/new-materialisms/> (Accessed 27 November 2020).

Sax, D. (2016) *The Revenge of Analog: Real Things and Why They Matter*. New York: Public Affairs.

Scherer, B. (2019) *The New Alphabet: (Un-)Learning Place*. Haus der Kulturen der Welt (HKW), Berlin. 9 January–13 January. Haus der Kulturen der Welt (HKW).

Schmidgen, H. (2013) 'The Materiality of Things? Bruno Latour, Charles Péguy and the History of Science', *History of the Human Sciences*, 26(1), pp. 3–28.

Sencindiver, S. Y. (2017) *New Materialism*. Available at:

<https://www.oxfordbibliographies.com/view/document/obo-9780190221911/obo-9780190221911-0016.xml> (Accessed: 11 March 2021).

Shannon, C. E. and Weaver, W. (1948) 'A Mathematical Theory of Communication', *The Bell System Technical Journal*, 27, pp. 379–423, 623–656.

Shannon, C. E. and Weaver, W. (1949) *The Mathematical Theory of Communication*. Urbana: University of Illinois Press.

Shaviri, S. (2014) *The universe of things: on speculative realism*. Minneapolis: University of Minnesota Press.

Signer, R. (2000) *Engpass at Aussendiesnt* [Installation]. Available at:

<https://www.tate.org.uk/tate-etc/issue-18-spring-2010/if-first-you-dont-succeed-celebrate> (Accessed: 19 March 2022).

Small, W. (1877) 'The Caxton Celebration – William Caxton Showing Specimens of his Printing to King Edward IV and his Queen' [Engraving], *The Graphic*, pp. 616–617.

Smith, C. (2016) Tutorial with Laura Rosser. November 2016.

- Soon, W. (2016) *Executing Liveness: An Examination of the Live Dimension of Code Inter-Actions in Software (Art) Practice*. Aarhus University.
- Available at:
- [https://www.academia.edu/37051235/Executing\\_Liveness\\_An\\_examination\\_of\\_the\\_live\\_dimension\\_of\\_code\\_inter\\_actions\\_in\\_software\\_art\\_practice](https://www.academia.edu/37051235/Executing_Liveness_An_examination_of_the_live_dimension_of_code_inter_actions_in_software_art_practice) (Accessed: 10 May 2020).
- Stafford, B. M. (1991) *Body Criticism: Imaging the Unseen in Enlightenment Art and Medicine*. Cambridge, MA: MIT Press.
- Stanhope, Z. (2019a) 'An Abundance of Loss', *Contemporary HUM*. Available at: <https://contemporaryhum.com/writing/an-abundance-of-loss/> (Accessed: 19 December 2021).
- Stanhope, Z. and Sharp, C. (eds.) (2019b) *Dane Mitchell: Post Hoc*. Milan: Mousse Publishing.
- Stocker, G. (2018) 'Error - The Art of Imperfection'. Interview with G. Stocker. Interview by V. Graf for *Ars Electronica festival*, 12 April, Berlin. Available at: <https://ars.electronica.art/aeblog/en/2018/04/12/error-the-art-of-imperfection/> (Accessed: 6 March 2022).
- Terranova, T. (2004a) 'Communication Beyond Meaning: On the Cultural Politics of Information', *Social Text*, 22, pp. 51–73.
- Terranova, T. (2004b) *Network Culture: Politics for the Information Age*. London: Pluto Press.

- Thompson, M. (2017) *Beyond Unwanted Sound: Noise, Affect and Aesthetic Moralism*. London: Bloomsbury Publishing.
- Thornton, C. (2018) *Materials of Resistance*. Available at:  
<https://clarethornton.com> (Accessed: 14 May 2019).
- Tomos, E. (2016–2019) *The Hand Tends to Return by a Shorter Path*. Available at: <https://elizabethtomos.com/work/print-machine> (Accessed: 31 December 2021).
- Treister, S. (2009–2011) HEXEN 2 [Diagram]. Available at:  
[www.suzannetreister.net](http://www.suzannetreister.net) (Access: 21 March 2022).
- Treister, S. (2016–2019) *SURVIVOR (F)/Mystical Apocalypse* [Diagram]. Available at:  
[https://www.suzannetreister.net/SURVIVOR\\_F/menuDiagrams.html](https://www.suzannetreister.net/SURVIVOR_F/menuDiagrams.html)  
(Access: 20 December 2021).
- Turning, A. M. (1950) 'I.—Computing Machinery And Intelligence', *Mind*, LIX, pp. 433–460.
- Tzara, T. (1920) *How to Make a Dadaist Poem* [Screenshot]. Available at:  
[https://www.moma.org/learn/moma\\_learning/themes/dada/word-play/](https://www.moma.org/learn/moma_learning/themes/dada/word-play/)  
(Access: 8 January 2023).
- Voegelin, S. (2019) 'Writing Sonic Fictions: Literature as a Portal into the Possibility of Art Research' in *Artistic Research and Literature*. Leiden: Brill, pp. 99–109.

- Wark, M. (2013) *Mckenzie Wark in Conversation with Montgomery Cantsin*.  
Available at: <https://www.furtherfield.org/mckenzie-wark-in-conversation-with-montgomery-cantsin/> (Accessed: 30 December 2020).
- Wiener, N. (1988) *The Human Use Of Human Beings: Cybernetics And Society*.  
London: Hachette Books.
- Williams, J. M. (1981) 'The Phenomenology of Error', *College Composition and Communication*, 32, pp. 152–168.
- Wolmark, J. (2004) *Cultural Hybrids, Post-Disciplinary Digital Practices and New Research Frameworks: testing the limits*. Available at:  
[https://www.researchgate.net/publication/228805691\\_Cultural\\_hybrids\\_post-disciplinary\\_digital\\_practices\\_and\\_new\\_research\\_frameworks\\_testing\\_the\\_limits](https://www.researchgate.net/publication/228805691_Cultural_hybrids_post-disciplinary_digital_practices_and_new_research_frameworks_testing_the_limits) (Accessed: 23 November 2021).
- Zur, O. and Walker, A. (2011) *On Digital Immigrants and Digital Natives: How the Digital Divide Affects Families, Educational Institutions, and the Workplace*. Available at: [http://www.zurinstitute.com/digital\\_divide.htm](http://www.zurinstitute.com/digital_divide.htm)  
(Accessed: 19 February 2022).

## APPENDICES

This section consists of a set of supporting texts and artistic projects that were produced within the registration period of the PhD, but are not part of the formal submission.

### Table of Contents

<i>Meta Diagramming Project: un-Learning Space: Diagrammatic</i>	
<i>Misadventures</i> .....	374
<i>Error as a site of breakdown and renewal: Can social media can be used to promote a society's new mode of living, labour and community?</i> .....	388
<i>Re-imagined Futures</i> .....	400
<i>The un-Learning Zone</i> .....	403
<i>Plymouth Whispers</i> .....	407
<i>Copycopycopy (Romano)</i> .....	410
<i>Speak and [mis]Spell</i> .....	412
<i>30-Minute Typo</i> .....	414
<i>Social Making Minutes</i> .....	415
<i>Type 'n' Tweet</i> .....	417

## Meta Diagramming Project: un-Learning Space: Diagrammatic Misadventures

I'm not so interested in single things; I like the collision between things. I'm not so interested in straight lines of thought; I prefer collisions of different lines of thought (Kelley, 2014, p. 57).

The artistic production of diagrams is central to my research methodology, as a mediation between different lines of thought that bridges abstract thinking and indexes relations.<sup>86</sup>

My PhD project investigates the significance of error. I argue that error is distinct in that it has the condition of being relational, and not capable of existing independently. The process of diagramming uncovers the interconnectedness of error with other things, through a mesh of colliding thoughts and information. The artist Mike Kelley's understanding of the diagram resonates with my own, in that we both believe that the diagram has the capacity to reveal the, at times disordered, connections between things.

The diagram thus emerges as a significant means of artistic enquiry. It is a system of thinking removed from the cognisant and (personally) challenging

---

<sup>86</sup> This paper was presented at SAR10\* Society for Artistic Research conference, March 2019.



discipline of writing and speaking. An important consideration of the diagram is that being understood is not its primary intention. Rather, the aim of the diagram is to expand our thinking and set thoughts in motion (O'Sullivan, 2016, p. 14). This observation provides me with the motivation in this research, through which I hope ideas will collectively unfold. I will not attempt to offer solutions, nor draw conclusions. Error will remain at the centre of this discussion, where ideas intersect each other as a precursor to a diagrammatic practice.

The diagram is commonplace in disciplines such as Freud's psychoanalysis, which is concerned with mapping relations or speculative thought. Although diagrams are often associated with simplified interpretations, they can be complex and research-based and a frequently used method within PhDs.

The diagram commonly consists of words, or marks, and lines of thought that map the relationships between things, connecting thoughts and visual information. Diagrams – in artistic practices, specifically – are not limited to written texts. For example, words are interchangeable with objects, photographs, hand-held digital devices and software, or the human voice and body. The diagram therefore exists beyond the textual as an artistic practice in and of itself.

There are two distinct types of diagrams. One kind of diagram attempts to link existing knowledge, such as the structural diagrams of Freud and Lacan. This type of diagram is an endeavour to formalise the nebulous and make something *real*. This objective approach is less suited to a desire for abstract thinking, since it positions the diagram as distanced from the body. The theorist and artist Simon O'Sullivan describes this as placing the idea itself above the human (2016, p.14). Such an instructional mode disregards opportunities for subjective reflection and negates the human subject as an active participant in the physical practice of diagramming.

Subsequently, there is the *conceptual* kind which supports the dynamic process of thinking *with* the diagram. This is where my interest lies. According to Gilles Deleuze, this mode of diagram is an 'abstract machine' for producing thoughts and connections (1987, p. 189-190). In contrast to Freud's diagrams, this approach 'foregrounds the potentialities of the body in the world' (O'Sullivan, 2016, p. 16). The connections (or disconnections) that Deleuze alludes to are significant in terms of discovering the often complex relations of error in a network of related things. In this text/section, I will focus on the conceptual use of the diagram to *map* thoughts and leave aside the more functional approaches.

The term *map* it is often discussed alongside *diagram*; however, they are distinct. As previously stated, the diagram can uncover how something works or the speculative relationship between things, whereas a map is commonly a visual representation of an imaginary or real area. The significant difference between the two is that a diagram does not necessarily contain information about an intended activity or idea. As such, and as philosopher Reviel Netz alludes to, a diagram has the ability to exist purely in the moment (2003, p. 30). This suggests there is a temporal issue that diagrams announce, which Deleuze speaks of (1987, p. 131) and which I will address later.

Considering the diagram as a form of cognitive map, it presents thinking as a place or space, mapping ideas, theories and concepts. Situating my diagrams more broadly in relation to cognitive maps and the philosophy of Deleuze means that diagrams become lines of thought that exceed representation. Deleuze defines the diagram as a 'no longer auditory or visual archive but a map' that does not distinguish 'between content and expression' (1988, p. 34). Deleuze's proposal that the diagram is an enmeshing of both conceptual thoughts and material information is useful when utilised to pick apart an entanglement of both tangible matter and abstract thinking. O'Sullivan refers to the artistic use of the conceptual diagram as 'the practice of the diagrammatic' (2016, p. 13). This positions the diagram in a contemporary art

context and proposes that a tradition of artists are engaged in criticality through the medium of the diagram. The philosopher Manuel DeLanda describes artistic diagramming as 'diagrammatic thinking' and argues for the need for a visual mapping of knowledge (2000, p. 30). Such mode of artistic inquiry explores relations as an aesthetic opportunity, which is valuable considering the relationality – and potential aesthetic quality – of error.

I position the diagram as a form of drawing practice, as a means of inquiry without consideration for uniformity or the readability of a written text. This provides a sense of subjective freedom and creates a space where error has the opportunity to exhibit agency and influence the diagram, both in its rendering and in terms of generating thoughts. Like a drawing, the diagram can operate at different speeds affecting relations and (dis)order. O'Sullivan draws parallels between the diagram and the speed of the sketch, in that it is ahead of conceptual thought and without concerns for equivalence of information (2016, p. 21). This resonates with my approach in understanding error as fluid and flexible and deserving of adaptability and a space to display agency. Hence my diagrammatic practice tends towards speed, a fast-forward mode, to override cognition and enable body and thought to interweave. This approach can also be observed in the responsiveness and spontaneity of Joseph Beuys's chalkboard diagrams (1972) which, created during a lecture,

provide a contrast to the more durational and considered watercolour diagrams mapping surveillance data by Suzanne Treister (2009–2011).

Treister's complex diagrams evolve from her inner thoughts that emerge and build up over time.

Error is related to space and time. Connections between error and interconnected things, or agents, often exist only in the instance of creation.

DeLanda maintains that the energetic system of words or marks creates actuality, even if only temporarily (2000, p.30). Each time a diagram is produced, new connections become manifest, implying how diagrams possess a *nowness* and a *liveness*. The theorist John Mullarkey refers to this place/space as the 'in-between' and suggests the diagram is a 'performative place-holder' (2011), where relationships exist for an indefinite amount of time. My production of diagrams likewise has a *liveness*, which offers understandings of errors that occur in the moment. Unable to exist autonomously, the diagram is an active part of a network of interrelated things, where it is capable of a co-constituted form of agency. It is both influential and influenced.

This conceptual mode of diagram can exist in the moment, or simultaneously announce a past and a future. Netz writes that 'The diagram is not a representation of something else, it is the thing itself' (2003, p. 60).

With that in mind, one can ask: What is the role of the diagram? O'Sullivan discusses the 'diagrams pragmatic character' where 'it moves things on' (2016, p. 14). This is important as it highlights the responsibility of the diagram itself, in that it changes things by expanding ideas, as opposed to bringing about conclusions, and each diagram demands further elucidation.

So how do we respond to the diagram? Is it an instigator of a further diagram? Does it sidestep the discursive? Or generate it? Can it be, as Deleuze writes, both a discursive and a non-discursive formation? Or is the diagrammatic, as Charles Sanders Peirce interprets, a perpetual quest for discovery and invention? I posit that diagrammatic thinking can foster unlearning and encourage not knowing, through an unravelling and picking apart of knowledge. Tentative lines and marks suggest disrupted thoughts and information. Knowledge can become lost amongst a mesh of ideas, creating a sense of unlearning and lack of resolution.

Deleuze writes of a search for solutions to problems that 'we do not possess a right to', where 'we are led to believe that problems are given ready-made, and that they disappear in response to the solution' (1994, p. 158). *Problem solving* is an interesting phrase when used by Deleuze in discussing diagrammatic thinking, as *solving* implies finding an answer. Effectively

resolving a problem is not the foremost intention of the diagram. A way of easing this tension is approaching a problem not as something that has a complete solution, but as something that opens up unimagined fields of possibilities. Deleuze advances this idea by discussing the problem-solving capabilities of the diagram as not necessarily reliant on humans or computers, but instead as something that may be instantiated by the energetic system, or material, itself. This calls for a discussion about the agency of nonhuman things (Latour), where subjects or objects have the conceivable ability to influence and take responsibility. Diagrams are more closely aligned to De Landa's description of diagrammatic 'spaces of energetic possibilities' (2000, pp. 23–30). As spaces that are influenced by the agency of nonhuman objects and information, where the artist is one part of the active relationship (Bennett, 2010, p. 21).

My research focuses on the hand-drawn diagram which can be considered as a response to post-digital conditions, where digital diagramming software are overlooked in favour of human touch and materiality.

The hand-drawn diagram rejects the practicality of digital software. The technologies of pencil and paper create a direct relationship between thought, body, and surface, without the need for an intermediary. O'Sullivan's

discussion of a diagram's lack of concern for equivalence of information is likewise a perspective that contributes to the notion of the post-digital diagram (2016, p. 21). Errors in thought or physicality occur, uncorrected by technology, and material errors are easily created in the rendering of the hand-drawn diagram. Pencil lines are imperfect, graphite marks smudge, paper creases and ideas overflow beyond the paper edge – although mistakes can be somewhat *erased* or rather changed with a rubber, the latter's ability to *delete* is nevertheless questionable. Unlike digital software, the hand-drawn diagram is not affected by the practicality of perpetual editing. Adversely, diagramming software provides the opportunity to edit and delete the errors I seek and embrace as creative possibilities, and the cognitive process of editing is distanced from the bodily act of diagrammatic thinking.

The physical errors which occur in my diagrams are certainly important, but not my sole concern. A more open and speculative approach to error is encapsulated by my adoption of Deleuze's phrase 'misadventures of thought' (1994, p.148), which disagrees with the dogmatic image that recognises only physical or literal error. Deleuze's expanded interpretation considers unconscious thoughts such as falsehoods or lack of truth as errors. This interweaves with Freud's concept of the unconscious mind which influences judgements, feelings, and behaviour. I adopt a synthesis of Deleuze's



*misadventure* (of thought) and Casone's *misbehaviour* (of technology) in my examination of error.

The diagram is a space/place where this expanded sense of error is manifest as an enmeshing of thoughts. This is apparent in the diagrams of the artist Barbara Balfour who explores errors in judgement. Balfour contributes to the post-digital practice through her aesthetic and diagrammatic use of handwritten sticky notes. The movable paper notes mimic the interactivity and editability of digital software where ideas can be repositioned several times. Balfour repurposes sticky notes (ubiquitous in office administration) into an unfixed diagrammatic form, as temporal reminders of what is important.

My own diagrams likewise suggest a post-digital sensibility, distinct in their lack of (digital) interactivity. The diagrammatic thinking occurs in *real-time* in the interactions between me, error, and things. Interactivity and editing are superfluous when freely exploring connections that are (like error) actual in the moment.

I perceive my diagrammatic practice as a playful space for misadventure. The diagram is a technology suited to exploring the relational agency of error, which is present in the activity and as subject matter. It maps the slippages

between types of post-digital error, and the way in which logic starts to break down when error occurs. I aim to identify a more fluid taxonomy of error which supports movement between literal and abstract understandings of error in post-digital print, and which reveals something about the tensions between different categories of error. These methods go against the ways that error is commonly understood in digital culture, where systems try to reduce, if not erase, error. I suggest, on the other hand, a more open and speculative approach to error and my interest is in a meshing together of tendencies; from the hard logic of communication to more subjective, artistic modes.

I position my diagrams broadly as cognitive maps, where lines of thought surpass representation. It is here that my thinking emerges, in the relation between the cognitive and unconscious. I see the relationships and spaces between categories of error, not as a means to tie error down to a specific definition; indeed, I am interested in the tension between a variety of different interpretations. My methodology is not just about making the diagram, but thinking with it, as an artistic practice in itself. Error starts to impose itself on the rendering of the diagram as a post-digital form, and it occurs in miscommunicated thoughts and where meaning wanders from the truth. There is a stuttering language and an uncertain stumbling flow that interrupts intentionality and knowing.

This concept is explored further in my project *Enchiridion* (2018) – which refers to a small manual or guidebook, and in this work is in the form of algorithmic disordered instruction sets. The project disrupts digital orderliness through a systematic process of creative disorder. Both this project and my diagrams suggest how artworks can fade in and out of meaning through the manifestation of errors, which deviate from knowing and logical thought. I create diagrams to think about error's categories, order, and connections, through which I focus on emerging relationships between my artistic projects and various error types. My diagrams and a set of projects have uncovered that individual projects sit amongst particular groups, or *clusters*, of errors. Through distinguishing my diagrammatic visual language from the textual (and lines of thought) into a system of *simplified* colour-coded marks, I place emphasis on the clusters/groups and new inter-connections. Voids and gaps that appear in the diagrams create space for unknowns. In this light, and returning to idea of unlearning, the diagram provides us with access to not knowing through an unfolding of relationship dynamics. Although not a central concern, the *fold*, which Deleuze discusses as a 'fabric of ontology', cannot be ignored in my research where *foldings* produce an inner and an outer surface (Deleuze *et al.*, 1993, p. 10). Deleuze describes diagrams as folded surfaces of thought layered over each other. This resonates with my diagrammatic mode,

both as a 'folding in' of external forces and folds of space and time (Deleuze et al., 1993, p. 12).

My project *[mis]Folding* (2018–2019) explores the diagram as a performative object. The process of folding and misfolding diagrams temporarily disrupts understanding and relationships in the project, where words, marks, and spaces are not logically arranged or understood. As the paper creases and folds, new connections manifest. Knowledge is reinterpreted in the moment as a temporal reality, from literal comprehension to a space of not knowing, and this is important in terms of unlearning and non-knowledge.

The artist collective *Plastique Fantastique* create collaborative performances that collectively *think* through diagramming, leaving aesthetic spaces without thought which is suggestive of agency beyond the artist and their intention. And the artist-led group *Banner Repeater* place the diagram in the public realm, exploring the event in terms of the qualities of the diagram itself. These diagrammatic practices present the diagram as a collaborative (or performative) device, capable of extending the discourse from between artist and nonhuman agents to, as Latour announces, between a network of human and nonhuman influences. This indicates how the diagram is a multifaceted

method, adept at exploring dynamic systems of relationships and ideas that exist in both time and space.

Peirce classifies the diagrammatic paradigm in terms of temporal and spatial relations (Burks, 1949, pp. 675–676). If the diagram is understood as a temporary place, it is conceivable that diagrams are a series of signs that are active in the moment they are used. The transitory nature of (the relationships in) conceptual diagrams is apparent when it is revisiting the diagram, where connections that once were actual have lost their poignancy. The question arises: Does this lend meaning to the way in which the diagram presents opportunity for us to individually or collectively unlearn?

Error as a site of breakdown and renewal: Can social media can be used to promote a society's new mode of living, labour and community?

The following pages are an extract from the *Parallax* publication, 2018–2021.

**Parallax**

**2018—2021**

**co/editors:**

**Paweł Mendrek / Martin Newth**

**Katowice / London / Plymouth / Göteborg**

**2022**

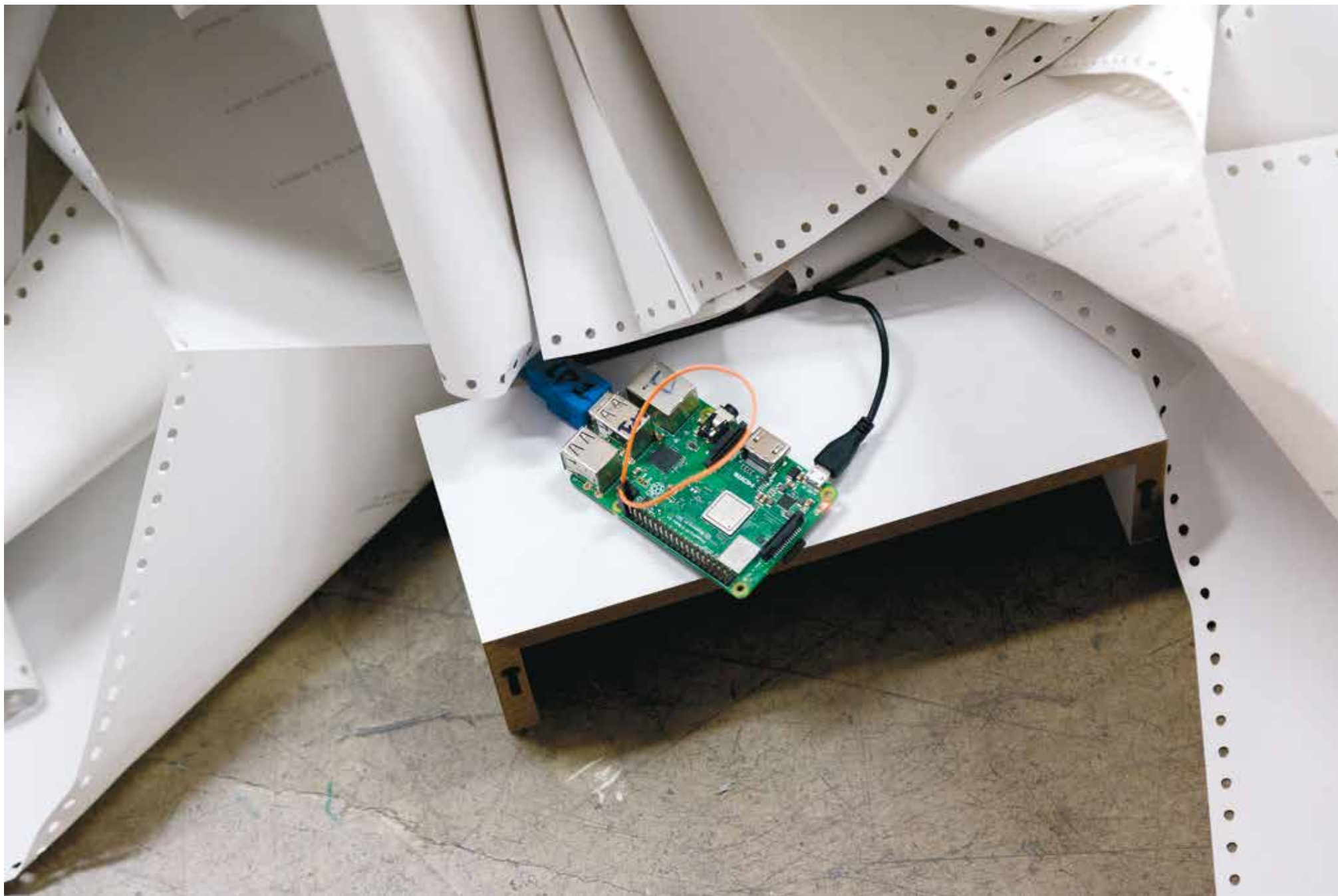

↑ Laura Rosser, *#upgrade*, 2019



Laura Rosser

*Error as a site of breakdown and renewal: Can social media can be used to promote a society's new mode of living, labour and community?*

**Błąd jako miejsce załamania i odnowy:  
czy media społecznościowe mogą zostać  
wykorzystane do promowania nowego modelu  
życia, pracy i wspólnoty?**

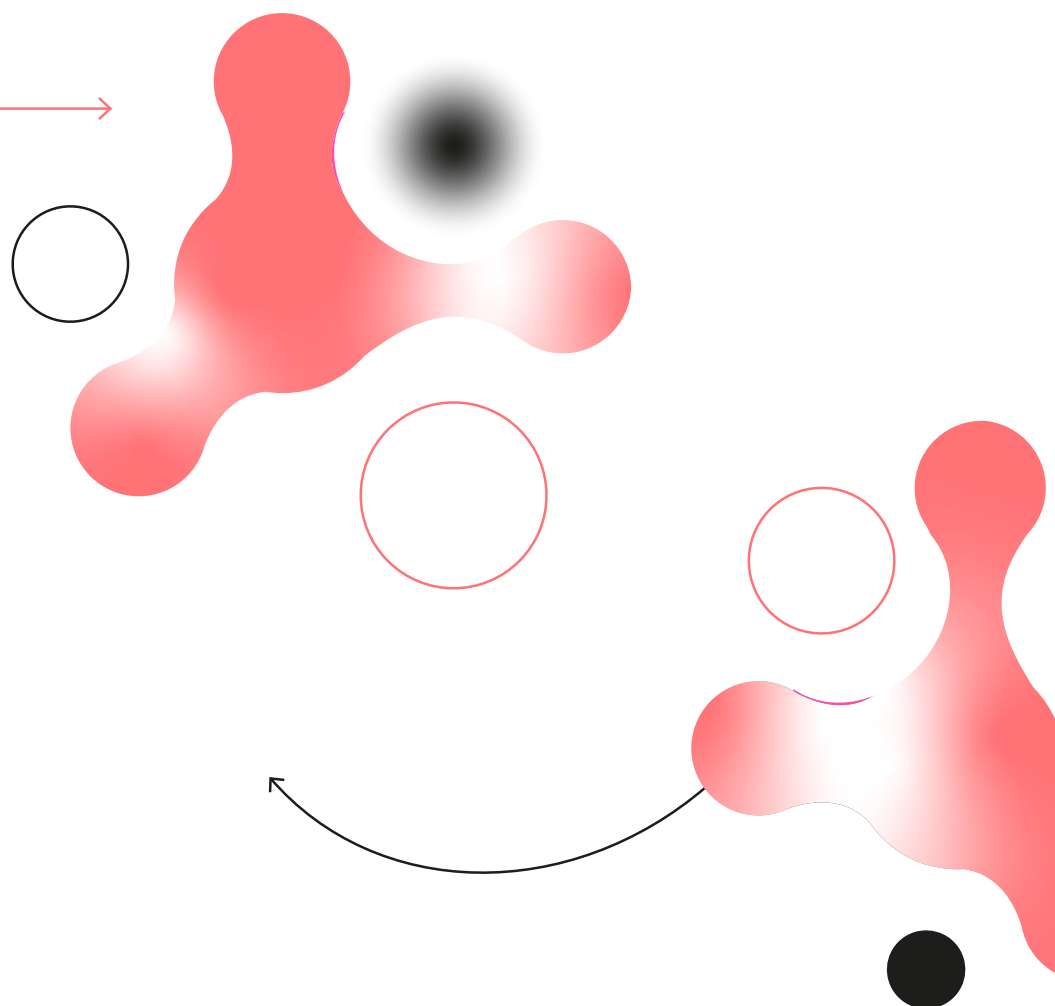

In 2019, the exhibition ‘*Sex, Suicide, Socialism, Spirit and Stereotypes*’ at the Kronika Centre for Contemporary Art, was the test space for a new project, #Upgrade which explored how social media can be used to promote a society’s new mode of living, labour and community.

My ambition for the project, and this accompanying text, is to unpick how the concept of *error* can be used to confront historic stereotypes and concerns for our networked, yet fractured society, and to disseminate a contemporary cultural identity.

At the point of writing we are amidst the coronavirus crisis, and it feels irresponsible to not also draw on the impact of the virus on how we feel now about our global and local communities and modes of connectivity. The concept of the network and community has never been under such tension, with politics, culture and society in disorder. Expanding and exploring our networks, online and offline, has never felt so significant for reimagining the current new world order, where injustices regarding stereotyping, otherness, labelling and categorisation are heightened. With this in mind, I will first reflect upon this uncertain time through drawing on Bruno Latour’s discussion of the (pre and post-covid) network (2020a, 2020b), as a method of framing my artistic enquiry which explores uncertainties of a networked society from the perspective of the post-digital condition, which suggests that people are no longer fascinated by technology or its advancement (Cascone, 2002).

The COVID-19 pandemic has reshaped our understanding of what it truly means to be a networked society. With people confined to their homes during lockdown, we rapidly re-shaped into online communities (for all facets of life: work, shopping, entertainment, socialising, opinion,

health and wellbeing). From this new and intensified virtual sense of being, a temporal powerlessness ensued. Followed by a tentative retaliation against being voiceless, against control and political uncertainty, and in our isolation a collective thinking is emerging about how, following the pandemic, we can create a better world to live in. From this catastrophe, can we create a society that is reflective of a contemporary identity and global community, freed from the errored aspirations of Brexit and other populist movements for a divided European society?

In an essay on pre- and post-crisis economic production, Bruno Latour points to how the coronavirus is ‘an incredible demonstration of network theory.’ (Latour, 2020a). Of particular interest for this text, is Latour’s suggestion that the personal and the collective are not as distinct as we may have thought (ibid.). That being so, despite our temporal enforced powerlessness, we have learnt the value of connectivity, a message of hope, a virtual hug, or a thumbs up, which can (like the virus) be easily spread. This ability to communicate across networks is as Latour claims, empowering. I wholly agree with Latour, as in some instances it has strengthened our connective resolve, with the Black Lives Matter<sup>1</sup> movement a critical example. The network (formed in 2013) ruptured out of our virtuality during the pandemic, to combat racism and the deeper issue of how people are categorised. The movement, which is now firmly on the frontline of global societal concerns, has connected people together from across the world to address historical unethical atrocities against black and minority ethnic people who have been marginalised, at times above and beyond COVID lockdown regulations. Pre-existing conditions have been exasperated during lockdown, with a disproportionate number of deaths from COVID among black people and those of Asian origins. Returning to Latour, our ‘personal and collective voices’ are shouting louder than ever before. It is time for change.

Outside of this critical and overdue call for action, the pandemic has undoubtedly compromised physical and bodily offline connections, not palpable via a screen (in a video call, chatroom, or social media feed) or through a network of computers. What happens if the concept of the

<sup>1</sup> The Black Lives Matter movement ‘affirm[s] the lives of Black queer and trans folks, disabled folks, undocumented folks, folks with records, women, and all Black lives along the gender spectrum. Our network centers those who have been marginalized within Black liberation movements.’ (<https://blacklivesmatter.com>, 2020)

network is challenged? Our awareness of others and our relationships are magnified and upgraded to a degree beyond our control. Pre-covid, digital progress has at points felt relentless, with an oppressive desire for connectivity, immediacy, knowledge, and truth. Post-covid there is a different reflective state emerging on what is possible, and what is necessary, in terms of both online and offline networks (reminding me once more of the impetus of the Black Lives Matter protests). This crisis has simultaneously highlighted and corrupted our communicative systems and structures, creating a tension between the material and immaterial, physical and virtual. As a society, we have become increasingly uncertain of facts and accuracy and suspect (human or non human) error, such as the computational systems that track the spread of COVID-19, or the biological virus itself which has the capability to detrimentally affect society, politics, and the economy. This calls for a timely re-think, a re-shaping, of our fragile networked society.

For this reason, my project *#Upgrade* is at the core of this discussion and is presented as a dilemma: as an artistic means of navigating the uncertainties of online social networks and our somewhat turbulent relationship with technology. The project is a dialogue between human and machine, which explores how social media can be used to distribute a new shared condition across systems, between bodies, to develop a collective future that is representative of current identities and community values. *#Upgrade* set out to interrogate whether social media can be used to create a refreshed social imaginary, and break up historical negative stereotypes affecting people from Bytom, Poland where the Kronika Gallery is located. The city was negatively impacted by two decades of political transformations and privatisation, notably reforms to the mining industry, causing high levels of unemployment. Bytom is a culturally rich and diverse place, yet it is also affected by a reputation for poverty and degradation. This labelling can be hard to shake off. Today, local authorities in Bytom are working to promote a positive image. My intention is that *#Upgrade* could contribute towards this positive sense of community and identity. Developing on local projects such as ‘Napraw Sobie Miasto’, or ‘fix the city yourself’ (Krajewski, 2010), I created a localised hashtag campaign (*#upgradethecity*), calling out to the people of Silesia to contribute to a Twitter feed on who Silesians are today; on how people feel and think *now*. This created a live archive for every person who lives in Silesia, or feels Silesian. The hashtag campaign uses the

collective local voice and potentiality of a networked society to confront outdated stereotypes, and disseminate a contemporary cultural identity and interpretation of the region.

In the gallery space, an Arduino computer is connected to two 1990s Polish dot matrix printers, which sporadically print real time tweets from localised twitter hashtag searches. Facilitating a dialogue between our virtual and physical selves, with momentary tweets afforded a permanence when embedded on the surface of the paper. As a register of transitory online encounters between people residing in Bytom and Silesia. One printer feed reveals people's data, mapping the participants physical locations through GPS co-ordinates and date and time of tweeting, calling attention to ethical decisions about what data is collected and how it is used, with the adjacent printer materialising participants short and often fractured thoughts and stuttering, broken, conversations. Both paper feeds spill onto the floor below, folding, layering, looping, and entangling.

Post-covid, this intertwining might serve as a gentle reminder of our concerns regarding a loss of physical connection, of touch. Where materiality and physicality has unknowingly become firmly enmeshed with immateriality. The network of cables feeding the printers and Arduino entwine tentatively within the fragile misfolded paper feeds. Relevant to both our pre- and post-covid society, this project evokes a connection between the physical and virtual, speculating on what is *material* and exploring systems of communication, knowledge sharing, and people's experiences of them; from the physicality of the printed page, to the materiality of the technological infrastructure that supports it or, more recently, the reticent materiality of the spoken word, or gesture on Zoom. The paradox of the printers and computer connecting the online network, is reflected in the duality of the paper feed<sup>2</sup> which acts as a tangible lineage connecting both analogue and digital, fast and slow. The artist and media critic Alessandro Ludovico writes of the importance of this relationship in publishing, where 'an inherently 'material' medium, still makes sense

2 In his text 'Post-digital Print: The Mutation of Publishing since 1864' Alessandro Ludovico analyses the alleged 'death of paper' (2012, p.8) and defines printed matter as 'a universal medium' (idid. p.9), resistant to newer digital mediums which claim to have advanced and superior qualities, capable of replacing printed paper and becoming the dominant medium.

in [the] 'immaterial' age' (Ludovico, 2012, p.10). This reminds me of how (different yet) inseparable they are.<sup>3</sup>

*#Upgrade* explores this tension and the pervasiveness of social media networks and how this might contribute towards distributing a positive, accurate sense of community, reflective of a contemporary collective voice, rather than historical knowledge, or outdated second hand opinion or speculation. Post-covid the significance of this enquiry has been intensified. Raising questions about those connections that contribute (or not) to our individual and shared ambitions for a better, kinder, more considerate, society. It is assumed that gathering and sharing knowledge creates a better understanding of the world we live in, with information being consumed at an increasingly fast pace as a result of technological developments. Consequently, our existence on social media makes us aware of much more than we have personally experienced (this has never more true than during the COVID lockdown epoch where we are hungry for, yet apprehensive of, knowledge). The writer Walter Lippmann wrote in 1922 how we live in 'second hand worlds' (p.205); highlighting that this is not a new problem. Although he was referring at the time to printed newspapers, this has parity with contemporary concerns regarding our dependence on technology. One can imagine how distancing from first-hand experience contributes to making false judgements of others. Or, is it as the philosopher John Dewey insisted, that the only reality that matters is the reality that people collectively construct (1960). This is an interesting proposition at a time when we seek information predominantly through the media. Are we forging a social imaginary that is actual only in its moment of conception, only to be quickly superseded by the next tweet? This *liveness* where nothing is static, where notions of time-space-place are broken down is significant, given our recent experiences and reliance on digitality, and where we are more than ever, capable of traversing fluidly between places and spaces. Indeed, how do we, as artists, navigate this unpredictable terrain and challenge concerns of information overload and being (dis)connected?

In *#Upgrade* error exposes the possibility of growth and change, and the agency of previously obsolete machines is used for social good. Error

3 In practical terms, the cost of producing digital versions of newspapers far out way the printed versions. Journalists have responded by using a hybrid, and retaining different modes for different types of news; fast paced for digital and longer term issues for paper, so the content is still relevant once in print.

is firmly at the centre of this artistic enquiry, from the errant stereotypes affecting national identities and the dissemination of incorrect information on social media, to my printer's errors arising from worn printer ribbons, or when the printers misfeed and print over the papers edge. Error exists as both activity and subject matter. There are tensions between different interpretations of error: from the binary (and strictly digital forms) to the more abstract and human ways we approach and think about error. That being so, one might propose a meshing together of these tendencies (revealed by the entwining of analogue and digital in *#Upgrade*) and enjoyment of the slippages between understandings, where error is capable of breaking down and disrupting networks. These methods go against the ways that errors are commonly understood in digital culture, where systems try to reduce, if not erase, error or breakdown. *#Upgrade* explores how error can become a site of renewal, and in doing so, how social media can both generate, and challenge, errant stereotypes and false information. Mark Nunes tantalisingly captures the potential of error:

'In its "failure to communicate," error signals a path of escape from the predictable confines of informatic control: an opening, a virtuality, a poesis.' (Nunes, 2011, p.3).

This project reveals how computational or algorithmic logic breaks down when error occurs, which is useful in terms of undermining networks and structures, promoting a process of reconnecting, reimagining and renewal. Thus, a breakdown in systematic logic presents an interruption to knowing and opportunity to un-learn, and re-learn how people feel and think *now, today*. This expanded sense of error has potential to open up new thinking; in that not knowing upholds new beginnings. This discussion twinned with the project, serves to breakdown interpretations of the network, positing errors in a network as a site of renewal.

The post-digital (Cascone, 2002) is a set of ideas, which I suggest, offers an artistic framework to reimagine the future of online and offline networks.<sup>4</sup> This concept provides a critical infrastructure for our relationship with the digital as it becomes pervasive. The musician and theorist

4 Musician and theorist Kim Cascone coined the term 'post-digital' in his paper 'The Aesthetics of Failure' in 2002, in response to how artists, in particular musicians, used failure as a creative tool in contemporary music.

Kim Cascone suggests that 'the revolutionary period of the digital information age has surely passed' (2002, p.392/393) and as a result, artists were no longer fascinated by technology and its advancement. Rather, the condition of the post-digital defines an attitude that embraces the technological flaws and errors that are inherent in all media, new and old, indeed undermining the distinction. Post-digital thinking is useful for this discussion as it is uninterested in categorisation or labelling, or debates of analogue versus digital, periodisation or technological progress<sup>5</sup>; rather, it posits a resistance to this logic. This resistance is reminiscent of recent activism, embodied in political, social and climate protests and reinforces Latour's argument that the individual and the collective are not as separate as one might think (Latour, 2020a).

This is a field of research that focuses on understanding the intersection between artistic practice and theory and technology, through creative exploration of the material, immaterial and imaginary in digital culture. It has become central to ideas of breaking or crashing technologies or systems, of degrees of failure. As such error signifies the end of the search for perfect technology, which I propose foresees new forms of usability and political reflections on the role of the internet and digital culture, as cultural commentary or resistance. Might this be a useful means of navigating shared concerns for social and political digital discourses? In essence, error and breaking down of networks can begin to mirror concerns for a fractured society, and understandings and expectations of the digital as it becomes less explicit and unambiguous. A collapsing or broken network is understood differently as a consequence of post-digital systems, practices and culture. Digital logic is commonly reductive, yet in artistic practice it is messier, and under post-digital conditions it is messier still, uncovering other creative and critical possibilities through which we can examine social, political and technological breakdown. The post-digital can nuance our understanding of online and offline networks and breaking-down, beyond a binary informational form. The project *#Upgrade* enacts a contingency rather than a discrete type of error, beyond binary or digital interpretations or mere mistake. Error therefore can be complex

5 An illustration of disruption to notions of *technological progress* is the revival of the Nokia 3310 mobile phone, which is an 'un-smart' phone only capable of making calls and sending texts, and was re-launched seventeen years after the original launch at the Mobile World Congress in 2017.

and disorderly and provides a means of accessing uncertainties and unknowns, and when in a network error can spread new ideas, new realities. Post-digital thinking has perhaps more relevance now than pre-covid, as it is beyond a set of ideas exploring our relationship with technology and is more interested in being human, than being digital.

How then might we re-think concerns of identity and difference in our fractured online and offline worlds to reflect the varied experiences of different groups of people? Returning back to the gravitas of the coronavirus and its impact on our modes of being, Latour asks that we might, 'reimagine how different the world could look if we learned from this [COVID] experience' (2020a). Might the Twitter feed on the gallery floor act as a script for a reimagined society? Latour proposes that we have learnt a significant lesson from this crisis, in that;

'We have actually proven that it is possible, in a few weeks, to put an economic system on hold everywhere in the world and at the same time, a system that we were told it was impossible to slow down or redirect.' (Latour, 2020b, p.1)

Although Latour is referring here to the suspension of globalisation and economic trade, it offers hope that this period of economic, societal and political upheaval is additionally a perfect time to put a stop to historic cultural wrongdoings. Is this not a call to re-think our connective structures in line with contemporary concerns for tangible change, which embraces how people belong to different categories that loop and entangle with each other, instilling a solidarity for social change? Are we now in a strong position to be able to confront the 'irreversible force of the train of progress' (ibid, p.1)? The post-covid period has problematised the notion of progress, which brings me neatly back to post-digitality, where progress is no longer assumed to be online or offline, and significantly, where nothing is certain. Which is perhaps something we can all relate to, uncertain times indeed. ●

**W**ystawa *Sex, suicide, socialism, spirit and stereotypes* zorganizowana w roku 2019 przez Centrum Sztuki Współczesnej Kronika była przestrzenią testowania nowego projektu #Upgrade, badającego, w jaki sposób media społecznościowe mogą promować nowy model życia, pracy i wspólnoty. Moją ambicją związaną z tym projektem oraz z prezentowanym tekstem jest analiza sposobu, w jaki błąd może zostać wykorzystany do skonfrontowania się z historycznymi stereotypami i problemami naszego usieciowionego, a mimo to podzielonego społeczeństwa oraz do propagowania współczesnej tożsamości kulturowej.

Pisząc te słowa w trakcie koronawirusowego kryzysu, czuję, że odpowiedzialność wymaga, by poruszyć kwestię oddziaływania wirusa na nasz stosunek do globalnych i lokalnych społeczności oraz modeli połączeń. Sama koncepcja sieci i społeczności nigdy dotąd nie znajdowała się pod taką presją, w dodatku w sytuacji nieładu panującego w polityce, kulturze i społeczeństwie. Rozwijanie i eksplorowanie naszych sieci – online i offline – nigdy dotąd nie wydawało się tak istotne ze względu na przeobrażenie obecnego nowego porządku światowego, w którym dochodzi do wzrostu niesprawiedliwości w obszarze stereotypowania, inności, etykietowania i kategoryzacji. Mając to na uwadze, zacznę od refleksji nad obecnymi niepewnymi czasami, opierając się przy tym na analizie Bruno Latoura dotyczącej (przed – i pocovidowej) sieci [2020a, 2020b], stanowiącej ramy dla moich poszukiwań twórczych w zakresie obszarów niepewności występujących w społeczeństwie usieciowionym w warunkach postdigitalnych, oznaczających wygaśnięcie fascynacji technologią i jej rozwojem [Cascone 2002].

Pandemia COVID-19 zmieniła nasze rozumienie tego, co naprawdę oznacza być społeczeństwem sieciowym. Zamknięci w domach w trakcie *lockdownu* gwałtownie przekształciliśmy się w społeczności online (we wszystkich obszarach życia, takich jak: praca, zakupy, rozrywka, relacje towarzyskie, poglądy, zdrowie i samopoczucie). To nowe, intensywne poczucie bytowania wirtualnego doprowadziło do wrażenia przejściowej bezsilności. Nasza kolektywna refleksja nad możliwością stworzenia lepszego świata po pandemii, dokonywana w izolacji, prowadzi do nieśmiałej jeszcze reakcji na odebranie głosu, kontrolę i polityczną niepewność. Czy na bazie obecnej katastrofy możemy stworzyć społeczeństwo odzwierciedlające współczesną tożsamość i globalną społeczność, wolne od błędnych aspiracji stojących za brexitem i innymi ruchami populistycznymi w podzielonej Europie?

W eseju na temat przed- i pokryzysowej produkcji gospodarczej Latour wskazuje na fakt, że koronawirus stanowi „niezwykłą demonstrację teorii sieci” [Latour 2020a]. Szczególnie interesująca jest w tym tekście sugestia badacza, że to, co osobiste i zbiorowe, nie jest tak odmienne, jak mogłoby się wydawać [Latour 2020a]. W tej sytuacji pomimo naszej tymczasowej, wymuszonej bezsilności poznaliśmy wartość pozostawania w kontakcie, dodawania sobie nadziei, wirtualnego uścisku lub poparcia, które również są w stanie rozprzestrzeniać się z prędkością wirusa. Ta zdolność do komunikacji w sieci, jak twierdzi Latour, dodaje poczucia sprawczości. Zgadzam się w pełni z tą opinią. Uważam, że w pewnych przypadkach wspomniana zdolność do komunikacji zwiększyła naszą determinację, czego dobitnym przykładem jest ruch Black Lives Matter<sup>6</sup>. Podczas pandemii społeczność ta (stworzona w roku 2013) wyrwała się ze strefy wirtualnej, by zwalczać rasizm i inne, głębsze sposoby kategoryzowania osób. Ruch ten, znajdujący się obecnie na pierwszej linii frontu walki z globalnymi problemami społecznymi, połączył ludzi z całego świata w zmaganiach z historycznymi niegodziwościami wyrządzanymi czarnoskórym i innym zmarginalizowanym mniejszościom etnicznym, czasem wychodząc poza przepisy *lockdownu*. W wyniku *lockdownu* istniejące trudne warunki życia uległy pogorszeniu, co skutkowało nieproporcjonalnie wyższą śmiertelnością spowodowaną wirusem wśród osób czarnoskórych i pochodzenia azjatyckiego. Wracając do Latoura, należy stwierdzić, że nasze „głosy osobiste i zbiorowe” brzmią głośniejsz niż kiedykolwiek wcześniej. Nadszedł czas zmian.

Poza tym istotnym i spóźnionym wezwaniem do działania pandemia niewątpliwie wpłynęła negatywnie na nasze fizyczne połączenia offline, których nie zastąpi kontakt przez ekran (w formie rozmowy wideo, czatu lub materiałów wyświetlanych w mediach społecznościowych) czy sieć komputerową. Co dzieje się, kiedy koncepcja sieci zostaje zakwestionowana? Nasza świadomość obecności innych i nasze relacje z nimi są rozwijane i ulepszone w stopniu pozostającym poza naszą kontrolą. Przed covidem proces cyfryzacji, z jego opresyjnym pragnieniem łączności, natychmiastowości, wiedzy i prawdy, sprawiał czasem wrażenie procesu, którego

6 Ruch Black Lives Matter „afirmuje życie czarnoskórych osób queer i trans, osób niepełnosprawnych, osób o nieregulowanym statusie, osób z kryminalną przeszłością, kobiet i wszystkich osób czarnoskórych wewnątrz całego spektrum gender. Nasza sieć skupia w ramach ruchów wolnościowych wszystkich tych, którzy zostali zmarginalizowani”. <https://blacklivesmatter.com>

nie można zatrzymać. Po covidzie pojawia się odmienny stan refleksji nad tym, co jest możliwe i konieczne, zarówno w odniesieniu do sieci online, jak i offline (co przywodzi mi po raz kolejny na myśl impet protestów Black Lives Matter). Kryzys ten jednocześnie uwypuklił i uszkodził nasze systemy i struktury komunikacyjne, tworząc napięcie pomiędzy tym, co materialne i niematerialne, fizyczne i wirtualne. Jako społeczeństwo staliśmy się coraz mniej pewni faktów i ich rzetelności. Gdy myślimy na przykład o systemach obliczeniowych śledzących rozprzestrzenianie się COVID-19 lub o samym wirusie, podejrzewamy (ludzkie lub nie ludzkie) błędy, które mogą mieć szkodliwy wpływ na społeczeństwo, politykę i gospodarkę. Konieczne staje się szybkie przemyślenie i przekształcenie naszego kruchego, sieciowego społeczeństwa.

Z tego powodu projekt *#Upgrade* znajduje się w centrum tej dyskusji, ucieleśniając pewną rozterkę: stając się artystycznym sposobem na nawigowanie po niepewnych obszarach internetowych sieci społecznościowych w ramach naszej nieco burzliwej relacji z technologią. Projekt ten, będący dialogiem człowieka z maszyną, bada, w jaki sposób media społecznościowe mogą zostać wykorzystane do rozpowszechniania nowego, wspólnego stanu, w jakim się znajdujemy – między systemami i ciałami. Badanie ma na celu rozwijanie wspólnej przyszłości, która odpowiada obecnym tożsamościom i wartościom społecznym. Poprzez *#Upgrade* chcę przekonać się, czy media społecznościowe można wykorzystać do stworzenia odświeżonej, społecznej wyobraźni i przełamania historycznych, negatywnych stereotypów dotyczących mieszkańców Bytomia – miasta, w którym znajduje się Centrum Sztuki Współczesnej Kronika. Negatywny wpływ na miasto miały dwie dekady przemian politycznych i prywatyzacji, a zwłaszcza reformy przemysłu wydobywczego, które spowodowały wysokie bezrobocie. Bytom jest miejscem kulturowo bogatym i zróżnicowanym, mimo to posiada opinię miejsca ubogiego i zdegradowanego. Nie będzie łatwo pozbyć się tej etykiety. Władze Bytomia pracują nad promowaniem pozytywnego wizerunku miasta. Chciałabym, aby *#Upgrade* przyczynił się do wzmocnienia tego pozytywnego poczucia wspólnoty i tożsamości. W oparciu o lokalne projekty takie jak Napraw Sobie Miasto [Krajewski 2010] stworzyłam lokalną kampanię hasztagową (*#upgradethecity*), zachęcającą osoby zamieszkujące Śląsk do wypowiedziania się na Twitterze na temat tego, kim są Ślązacy, jak czują i w jaki sposób myślą teraz. Stworzyło to żywe archiwum dla każdej osoby, która mieszka na Śląsku lub czuje się Ślązakiem. Kampania hasztagowa wykorzystuje zbiorowy, lokalny głos

i potencjał sieciowego społeczeństwa do konfrontacji z przebrzmiałymi stereotypami i do upowszechniania współczesnej tożsamości i interpretacji kulturowej regionu.

W przestrzeni galerii umieszczony został komputer Arduino, podłączony do dwóch polskich drukarek igłowych z lat 90. XX wieku, które od czasu do czasu drukują w czasie rzeczywistym tweety z lokalnie wyszukiwanymi hasztagami. W ten sposób tworzy się dialog pomiędzy naszymi bytami wirtualnymi a fizycznymi, podczas którego ulotne tweety uzyskują trwałość poprzez umieszczenie ich na papierze. Tweety stają się więc rejestrem krótkotrwałych spotkań online pomiędzy mieszkańcami Bytomia i Śląska. Jeden z wydruków ujawnia dane osób poprzez mapowanie fizycznej lokalizacji uczestników za pomocą współrzędnych GPS oraz pokazuje datę i godzinę tweetowania, prowokując do refleksji nad etycznymi aspektami gromadzenia i wykorzystywania danych. Z kolei sąsiednia drukarka materializuje krótkie i często porwane myśli oraz zacinającą się, przerywaną rozmowę uczestników. Obydwa wydruki spadają na podłogę, zawijając się, układając, zapętłając i zaplątując (rysunek 3).

W czasach pocovidowych to przeplatanie się, w którym materialność i fizyczność w sposób niezauważalny mocno wplatają się w niematerialność, może delikatnie przypominać nam o naszych niepokojach związanych z utratą fizycznej więzi, dotyku. Sieć kabli zasilających drukarki i Arduino nieśmiało splata się z delikatnymi, źle uformowanymi zwałami papierowych wydruków. Projekt ten, odnoszący się zarówno do przed-, jak i pocovidowego społeczeństwa, wskazuje na związek pomiędzy tym, co fizyczne, i tym, co wirtualne; spekuluje na temat tego, co materialne i eksploruje systemy komunikacji, dzielenia się wiedzą oraz ludzkie doświadczenia z nimi związane; od fizyczności drukowanej strony do materialności infrastruktury technologicznej, która za nią stoi, lub powściągliwej materialności słowa czy gestu, przekazywanych ostatnio za pomocą aplikacji Zoom. Paradoks drukarek i komputera połączonych z siecią online znajduje odzwierciedlenie w dwoistej naturze papierowego wydruku<sup>7</sup>, który działa jak namacalna linia łącząca analogowe z cyfrowym, szybkie z wolnym.

7 W publikacji *Post-digital Print: The Mutation of Publishing since 1864* Alessandro Ludovico analizuje rzekomą „śmierć papieru” i definiuje druk jako „medium uniwersalne”, które jest odporne na nowsze media cyfrowe, cechujące się większym stopniem zaawansowania, lepszą jakością i dążące do zastąpienia papieru, przyjęcia pozycji medium dominującego [Ludovico 2012: 8–9].

Artysta i krytyk medialny Alessandro Ludovico pisze o znaczeniu tej relacji w działalności wydawniczej, gdzie „medium z natury »materialne« ma nadal sens w epoce »niematerialnej«” (Ludovico 2012: 10), każąc pamiętać jak nierozłączne, choć różne, to zjawiska<sup>8</sup>.

#Upgrade bada to napięcie i wszechobecność sieci mediów społecznościowych oraz sposób, w jaki mogą się one przyczynić się do rozpowszechniania pozytywnego, właściwego poczucia wspólnoty, który odzwierciedla współczesny głos zbiorowy, a nie wiedzę historyczną czy też nieaktualną, zapożyczoną opinię lub spekulacje. W okresie pocovidowym wzrosła istotność tego zagadnienia, zadaje się pytania o połączenia, które przyczyniają się (lub nie) do realizacji naszych indywidualnych i wspólnych ambicji dotyczących lepszego, życzliwszego i bardziej rozważnego społeczeństwa. Zakłada się, że gromadzenie i dzielenie się wiedzą przekłada się na lepsze zrozumienie świata, w którym żyjemy, co odbywa się przy coraz szybszym pochłanianiu informacji, możliwym dzięki rozwojowi technologicznemu. W rezultacie nasza obecność w mediach społecznościowych pozwala uświadomić sobie o wiele więcej, niż bylibyśmy w stanie, gdybyśmy opierali się na osobistym doświadczeniu (to spostrzeżenie nie było nigdy prawdziwsze niż w epoce koronawirusowego *lockdownu*, który cechuje jednocześnie głód wiedzy i strach przed nią). W roku 1922 pisarz Walter Lippmann stwierdził, że żyjemy w „światach z drugiej ręki” [1922: 205]. Pisarz podkreślił, że nie jest to nowy problem. Choć miał na myśli prasę drukowaną, jego opinię można odnieść do współczesnych obaw związanych z uzależnieniem od technologii. Można sobie wyobrazić, w jaki sposób oddalenie się od doświadczeń z „pierwszej ręki” przyczynia się do błędnych osądów na temat innych. Może jednak jest tak, jak twierdził filozof John Dewey, że jedyna rzeczywistość, która ma znaczenie, to rzeczywistość wspólnie konstruowana przez ludzi [1960]. Propozycja ta w czasach, gdy informacji poszukujemy głównie za pośrednictwem mediów, wydaje się interesująca. Czy tworzymy społeczną wyobraźnię, aktualną w momencie powstania tweeta i wypieraną natychmiast przez kolejną wiadomość? Ta „żywość”, w której nic nie pozostaje statyczne,

8 W praktyce koszt produkcji cyfrowych wersji gazet znacznie przewyższa koszt wersji drukowanych. Dziennikarze zareagowali, stosując hybrydę i zachowując różne tryby dla różnych typów wiadomości; tryb cyfrowy dla spraw nagłych i papierowy dla kwestii o dłuższym czasie życia, co pozwala słowu drukowanemu na zachowanie aktualności.

a pojęcia „czasu”, „przestrzeni” i „miejsca” zostają rozbite, jest istotna, jeśli weźmiemy pod uwagę nasze ostatnie doświadczenia i poleganie na cyfrowości. Jesteśmy w niej – bardziej niż kiedykolwiek – zdolni do płynnego podróżowania pomiędzy miejscami i przestrzeniami. W jaki sposób my, artyści, poruszamy się po tym nieprzewidywalnym terenie i podchodzimy do obaw związanych z przeciążeniem informacyjnym i byciem (nie)połączonym?

W *#Upgrade* błąd odsłania możliwość wzrostu i zmiany, a pośrednictwo maszyn uznawanych dotąd za przestarzałe jest wykorzystywana dla dobra społecznego. Błąd jest zdecydowanie w centrum tego artystycznego poszukiwania – od błędnych stereotypów dotyczących tożsamości narodowej i rozpowszechniania błędnych informacji na portalach społecznościowych, po błędy mojej drukarki wynikające ze zużycia taśm barwiących lub niewłaściwego podawania papieru i drukowania poza jego krawędzią. Błąd istnieje zarówno jako działanie, jak i przedmiot działania. Istnieje napięcie pomiędzy różnymi interpretacjami błędu: od form binarnych (i ściśle cyfrowych) do bardziej abstrakcyjnych i ludzkich sposobów podejścia do błędu i myślenia o nim. W tej sytuacji można by zaproponować połączenie tych tendencji (ujawnionych przez splatanie się w *#Upgrade* elementów analogowych i cyfrowych) i cieszenie się rozbieżnymi rozumieniami, z błędem będącym w stanie uszkodzić sieci lub zakłócić ich działanie. Metody te pozostają w sprzeczności ze sposobem rozumienia błędu w kulturze cyfrowej, w której systemy starają się zredukować – jeśli nie usunąć – błąd lub awarię. *#Upgrade* bada, w jaki sposób błąd może stać się miejscem odnowy, a tym samym jak media społecznościowe mogą zarówno generować, jak i kwestionować błędne stereotypy i fałszywe informacje. W sposób ekscytujący potencjał błędu ujmuje Mark Nunes: „Przez swoją »porażkę komunikacyjną« błąd sygnalizuje drogę ucieczki od przewidywalnych ograniczeń kontroli informatycznej: otwarcie, wirtualność, poezję” – [2011: 3].

Przedstawiany projekt pokazuje, w jaki sposób logika obliczeniowa lub algorytmiczna załamują się w przypadku wystąpienia błędu. Jest to przydatne w kontekście podważania sieci i struktur i promowania procesu ponownego łączenia, wymyślania na nowo i odnowy. Tak więc załamanie się systematycznej logiki stanowi przerwę w zdobywaniu wiedzy i okazję do tego, by zapomnieć i ponownie poznać, w jaki sposób ludzie czują i myślą teraz, dziś. To poszerzone rozumienie błędu ma potencjał, by pokazać nowy, inny sposób myślenia, w którym niewiedza stanowi bazę dla nowego

początku. Dyskusja, połączona z projektem, przyczynia się do przełamania interpretacji sieci, ukazując błędy wewnątrz niej jako miejsce odnowy.

Postdigitalność [Cascone 2002] stanowi zespół idei, które – jak sugeruję – oferują ramy artystyczne dla ponownego wyobrażenia sobie przyszłości sieci online i offline<sup>9</sup>. Koncepcja ta zapewnia krytyczną infrastrukturę dla naszych relacji z rzeczywistością cyfrową, w miarę jak staje się ona wszechobecna. Muzyk i teoretyk Kim Cascone sugeruje, że „rewolucyjny okres ery informacji cyfrowych na pewno minął” [2002: 392–393], w rezultacie czego artyści nie są już zafascynowani technologią i jej rozwojem. Zamiast tego postdigitalność określa podejście, które akceptuje wady i błędy technologii, właściwe dla wszystkich mediów – nowych i starych, faktycznie unieważniając to rozróżnienie. Myślenie postdigitalne przywoływane jest w tej dyskusji, ponieważ nie interesuje się ono kategoryzacją czy etykietowaniem ani też debatami nad analogowością przeciwstawioną digitalizacji, periodyzowaniem czy postępowaniem technologicznym<sup>10</sup>, a raczej przeciwstawia się tej logice. Ten sprzeciw przypomina niedawny aktywizm, ucieleśniony w protestach politycznych, społecznych i klimatycznych i wzmacnia argument Latoura, że jednostka i zbiorowość nie są tak od siebie oddzielone, jak można by sądzić [Latour, 2020a].

Jest to dziedzina badań, która koncentruje się na zrozumieniu krzyżowania się praktyki artystycznej, teorii i technologii poprzez twórczą eksplorację tego, co materialne, niematerialne i wyobrażone w kulturze cyfrowej. Stała się ona centralnym elementem idei niszczenia lub rozbijania technologii i systemów, awarii różnego stopnia. Błąd w istocie oznacza bowiem koniec poszukiwań idealnej technologii, ze zwrotem – jak proponuję – w kierunku przewidywania nowych form użyteczności Internetu i kultury cyfrowej oraz refleksji politycznej nad ich rolą jako kulturowego komentarza czy formy sprzeciwu. Czy może to być użyteczny sposób na wprowadzanie wspólnych obaw w strefę cyfrowych dyskursów społecznych i politycznych?

9 Muzyk i teoretyk Kim Cascone ukuł termin „postdigitalny” w odpowiedzi na sposób, w jaki artyści, w szczególności muzycy, wykorzystywali we współczesnej muzyce awarię jako narzędzie twórcze.

10 Ilustracją dla zjawiska zakłócenia pojęcia postępu technologicznego jest przykład odrodzenia telefonu komórkowego nokia 3310, będącej urządzeniem „nie-smart”, zdolnej jedynie do wykonywania połączeń i wysyłania wiadomości tekstowych. Produkcja tego modelu została ponownie uruchomiona w roku 2017 podczas Mobile World Congress, siedemnaście lat po jego pierwszym wejściu na rynek.



W gruncie rzeczy błędy i awarie sieci mogą zacząć odzwierciedlać obawy związane z rozbićciem społeczeństwa oraz poziom zrozumienia i oczekiwań wobec rzeczywistości cyfrowej, w miarę jak staje się ona mniej wyraźna i jednoznaczna. Awaria sieci jest rozumiana odmiennie – jako konsekwencja postdigitalnych systemów, praktyk i kultury. Z reguły redukcyjna logika cyfrowa w praktyce artystycznej wprowadza jednak więcej nieporządku, który wzrasta w warunkach postdigitalnych, co prowadzi do odkrycia kreatywnych i krytycznie istotnych możliwości, dzięki którym możemy badać momenty załamania społecznych, politycznych i technologicznych. Postdigitalność może niuansować nasze rozumienie sieci online i offline i ich załamania poprzez wychodzenie poza binarną formę informacji. Projekt #Upgrade wprowadza raczej przypadkowy niż określony typ błędu, sytuujący się poza interpretacjami binarnymi lub cyfrowymi czy zwykłą pomyłką. Błąd może być zatem złożony i nieuporządkowany oraz umożliwić dostęp do tego, co niepewne i niewiadome. W sieci natomiast błąd może rozprzestrzeniać nowe idee, nowe rzeczywistości. Myślenie postdigitalne być może ma teraz większe znaczenie niż przed covidem, ponieważ wykracza poza zestaw idei badających nasze relacje z technologią i w większym stopniu przejawia zainteresowanie byciem człowiekiem niż bytem cyfrowym.

Jak więc możemy ponownie przemyśleć kwestie tożsamości i różnic w naszych pękniętych światach online i offline, tak aby odzwierciedlić różnorodność doświadczeń wielu grup? Wróćmy do znaczenia koronawirusa i jego wpływu na nasze sposoby bycia. Latour pyta, czy możemy „wyobrazić sobie, jak różny mógłby być świat, gdybyśmy wyciągnęli wnioski z tego [koronawirusowego] doświadczenia” [2020a]. Czy zwinięte na podłodze galerii wydruki z Twittera mogą stanowić scenariusz przemyślanego na nowo społeczeństwa? Latour sugeruje, że wyciągnęliśmy z kryzysu istotną naukę, polegającą na tym, iż: „Udowodniliśmy, że w ciągu kilku tygodni możliwe jest jednoczesne zatrzymanie systemu gospodarczego na całym świecie, systemu, o którym powiedziano nam, że nie da się go spowolnić ani przekierować” [2020b: 1].

Chociaż Latour mówi tutaj o zawieszeniu globalizacji i handlu, zjawisko to niesie nadzieję, że ów okres wstrząsów gospodarczych, społecznych i politycznych będzie dodatkowo doskonałym momentem, aby położyć kres historycznym nadużyciom kulturowym. Czyż nie jest to wezwanie do ponownego przemyślenia struktur naszych połączeń, pozostającego w zgodzie z dążeniem do uzyskania namacalnej zmiany uwzględniającej fakt, że ludzie należą do różnych kategorii, które zapętłają się i splata-

ją ze sobą, której towarzyszy zaszczepianie solidarności w działaniu na rzecz zmiany społecznej? Czy mamy teraz pozycję na tyle silną, by móc stawić czoła „nieodwracalnej sile »pociągu postępu«” [2020b: 1]? Okres postcovidowy sproblematyzował pojęcie postępu, co sprowadza mnie do postdigitalności, w której nie zakłada się już, że postęp ma miejsce w trybie online lub offline i – co istotne – w której nic nie jest pewne. Ostatnie spostrzeżenie jest prawdopodobnie przecuciem, które mamy w sobie wszyscy – czasy są rzeczywiście niepewne. ●

## References

- CASCONE K.** [2002], *The aesthetics of failure: 'Post-Digital' Tendencies in contemporary computer music*, “Computer Music Journal” 24(4) Winter, Cambridge, MA: MIT Press, online: [http://www.bussigel.com/systemsforplay/wp-content/uploads/2014/05/Cascone\\_Aesthetics.pdf](http://www.bussigel.com/systemsforplay/wp-content/uploads/2014/05/Cascone_Aesthetics.pdf) [accessed: 25.07.2020].
- DEWEY J.** [1960], *The Quest for Certainty: A Study of the Relation of Knowledge and Action (Gifford Lectures 1929)*, Ontario, Canada: Capricorn Books.
- KRAJEWSKI A.** [2010], *Napraw Sobie Miasto*, Facebook.com, online: [https://www.facebook.com/naprawsobie\\_miasto/](https://www.facebook.com/naprawsobie_miasto/) [accessed: 25.07.2020].
- LATOUR B.,** Watts, J. [2020a] *Bruno Latour: This is a global catastrophe that has come from within*, “The Guardian” (6.06), online: <https://www.theguardian.com/world/2020/jun/06/bruno-latour-coronavirus-gaia-hypothesis-climate-crisis> [accessed: 25.07.2020].
- LATOUR B.** [2020b], *What protective measures can you think of so we don't go back to the pre-crisis production model?*, S. Muecke (trans.), online: [http://www.bruno-latour.fr/sites/default/files/downloads/P-202-AOC-ENGLISH\\_1.pdf](http://www.bruno-latour.fr/sites/default/files/downloads/P-202-AOC-ENGLISH_1.pdf) [accessed: 25.07.2020].
- LIPPMAN W.** [1922], *Public Opinion*. New York: MacMillan.
- LUDOVICO A.** [2012], *Post-digital print: The mutation of Publishing Since 1894*, Onomatopee, online: [https://monoskop.org/images/a/a6/Ludovico\\_Alessandro\\_-\\_Post-Digital\\_Print.\\_The\\_Mutation\\_of\\_Publishing\\_Since\\_1894.pdf](https://monoskop.org/images/a/a6/Ludovico_Alessandro_-_Post-Digital_Print._The_Mutation_of_Publishing_Since_1894.pdf) [accessed: 25.07.2020].
- NUNES M.,** ed. [2011], *Error: Glitch, Noise, and Jam in New Media Cultures*, London: Bloomsbury.

## Re-imagined Futures

Co-written by Karen Abadie, Molly McAndrews and Laura Rosser. Published in *Network Imaginaries* by Hackers & Designers, 2021.

*Re-imagined Futures* was a set of workshops introduced at the Hackers and Designers online summer academy in 2021, by a collective of artists including myself, Karen Abadie and Molly McAndrews. We hoped to challenge the concept of the network and ideas of community during a time of global (dis)order, that was rupturing from the Covid-19 pandemic.

The workshops were a response to the break-ing-down of day-to-day communication and logical thinking. We looked for uncertainty in a space of assumed certainty; wikiHow. The questionable logic of wikiHow instruction sets provided instructional content as a subjective, temporal solution. WikiHow enables the public to modify and update content and presents a framework of open collaboration, as it is a collective work in progress of sorts. Using algorithmically reproduced instruction sets from wikiHow, that spanned between meaning and nonmeaning, logical and abstract thought, we invited participants to re-shape and re-think uncertain times and look to a re-imagined future.

The series of short workshops connected users through re-scripting how-to webpages, collaborative writing, and diagramming spaces.



Figure 73: *Network Imaginaries. Re-imagined Futures: wikiHow, Hackers & Designers* (2021, pp. 196–197).

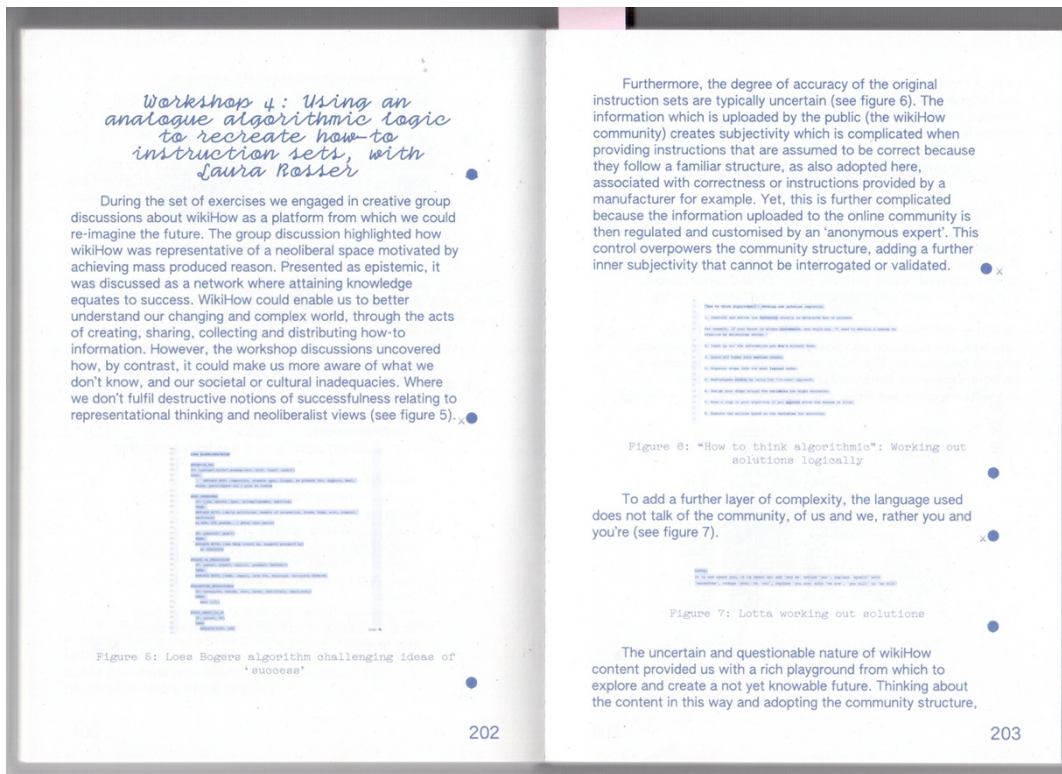

Figure 74: Network Imaginaries. Re-imagined Futures: wikiHow, Hackers & Designers (2021, pp. 202–203).

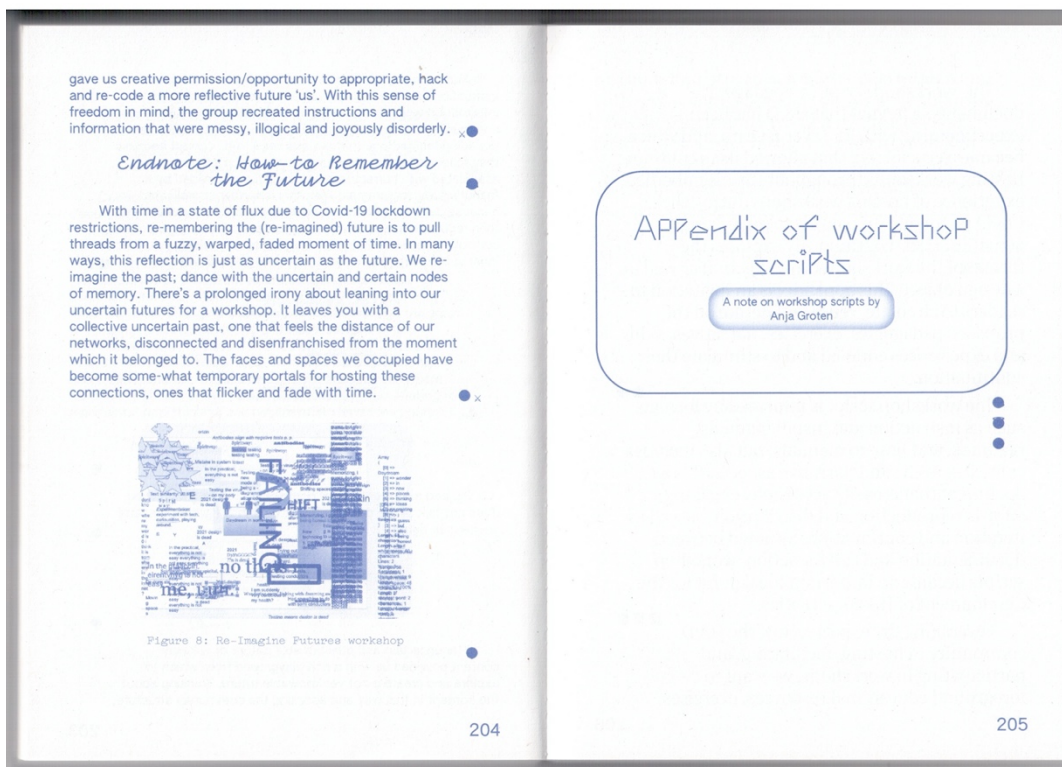

Figure 75: Network Imaginaries. Re-imagined Futures: wikiHow, Hackers & Designers (2021, pp. 204–205).

## The un-Learning Zone

BABE, Arnolfini, Bristol, 30–31 March 2019

*The un-Learning Zone* is a creative response to online learning platforms, which are a contemporary approach to learning. When instruction sets or how-to guides become digital, or are produced digitally, it is assumed that they are authentic and follow a logical structure. However, YouTube videos or Wiki guides are complicated mediums in that they are highly subjective.

*The un-Learning Zone* disrupts digital orderliness through a systematic process of creative disorder. This mobile service provides participants with dot matrix printed how-to guides that are reproduced in order to disrupt reason. The project aims to suggest how artworks can fade in and out of meaning through the manifestation of errors, which deviate from knowing and logical thought.

The project challenges the idea of the static library zone. In 2018, at the Bristol Artist Book Event (BABE) held at Arnolfini, the mobile project circulated around the gallery, engaging in conversation about relationships with books and online learning spaces. Using a car battery with a 240volt convertor, the portable dot matrix printer did not have to rely on a connection to electric sockets. This enabled me to roam the book fair and print booklets of

reproduced errored instructions from wikiHow on a topic of the participants' choice – hence, the project came to represent a live library of sorts.



Figure 76: *The un-Learning Zone* (Rosser, 2019). Detail of front cover blanks.



Figure 77: *The un-Learning Zone* (Rosser, 2019). Details of participants at BABE at Arnolfini.



Figure 78: *The un-Learning Zone* (Rosser, 2019). Details of participants at BABE at Arnolfini.



Figure 79: *The un-Learning Zone* (Rosser, 2019). Portable print laboratory, including battery-powered printer and finishing equipment.



## **Plymouth Whispers**

Plymouth Art Weekender, 28–30 September 2018.

Plymouth Whispers was a three-day socially engaged project created for the Plymouth Art Weekender festival in 2018. Working with students from the University of Plymouth, we spread instruction sets across the city to encourage face to face conversation, as a commentary on the way we communicate in online spaces and how false information is distributed on the internet, with the aim of raising questions on the accuracy of online information.

A sub-project, Halftime Whispers in The Park, was also held at the Ashbourne Arts Festival in August 2018.



Figure 80: *Plymouth Whispers* at Plymouth Art Weekender (Rosser, 2018). Detail of participants from Instagram.



Figure 81: *Plymouth Whispers* at Plymouth Art Weekender (Rosser, 2018). Detail of participants from Instagram.



Figure 82: *Plymouth Whispers* at Plymouth Art Weekender (Rosser, 2018). Detail of participants.



Figure 83: *Plymouth Whispers* at Plymouth Art Weekender (Rosser, 2018). Detail of whispering participants.

## Copycopycopy (Romano)

Copycopycopy (Romano) is a video created in 2018 using an online translation tool with the objective of producing an errored version of the lyrics from 'Copy Shop' by the German rapper, Romano (2017). The original lyrics are a narrative on the artist's family business, a copy shop, in Berlin.

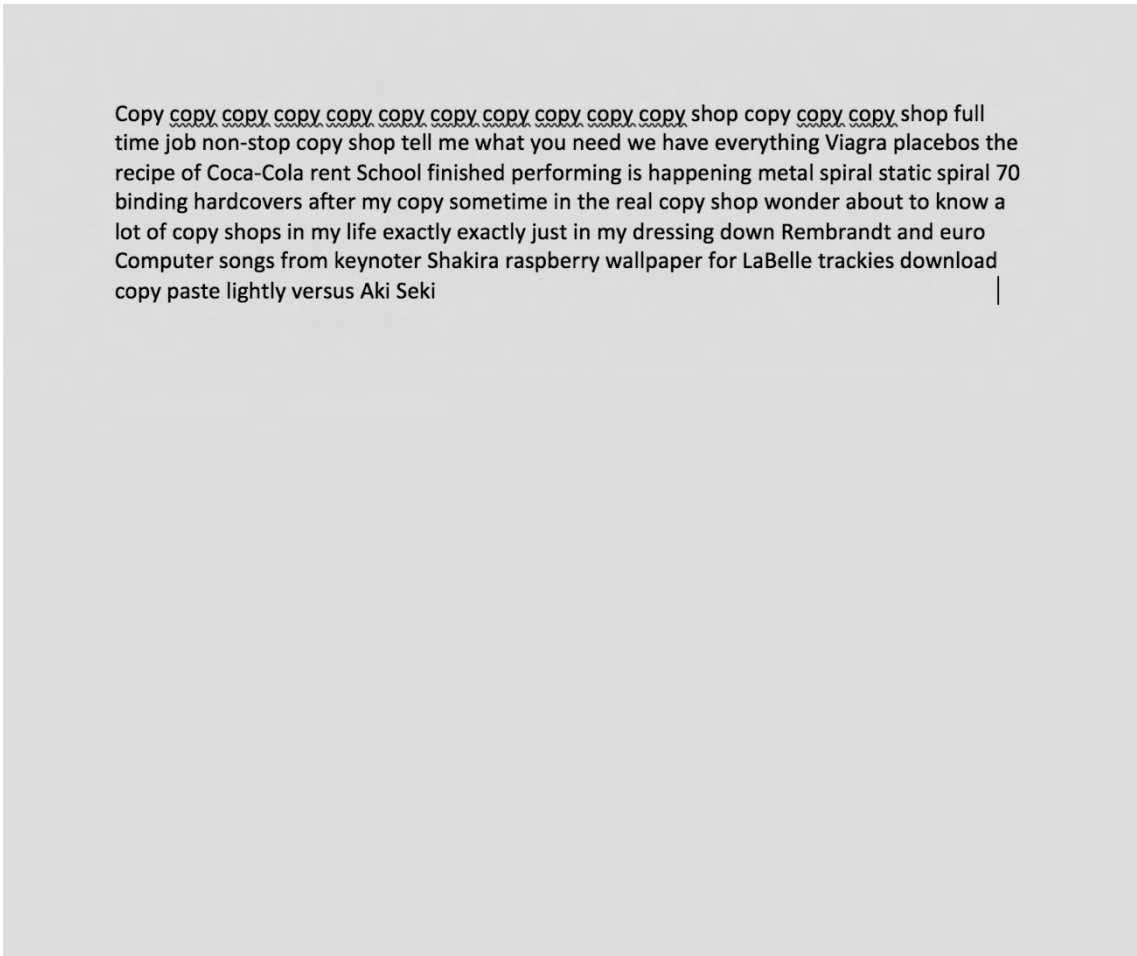

Copy copy copy copy copy copy copy copy copy copy copy copy shop copy copy copy shop full  
time job non-stop copy shop tell me what you need we have everything Viagra placebos the  
recipe of Coca-Cola rent School finished performing is happening metal spiral static spiral 70  
binding hardcovers after my copy sometime in the real copy shop wonder about to know a  
lot of copy shops in my life exactly exactly just in my dressing down Rembrandt and euro  
Computer songs from keynoter Shakira raspberry wallpaper for LaBelle trackies download  
copy paste lightly versus Aki Seki |

Figure 84: *Copycopycopy (Romano)*, 2018. Video still.

Copy copy copy copy copy copy copy copy copy copy copy copy shop copy copy copy shop full  
time job non-stop copy shop tell me what you need we have everything Viagra placebos the  
recipe of Coca-Cola rent School finished performing is happening metal spiral static spiral 70  
binding hardcovers after my copy sometime in the real copy shop wonder about to know a  
lot of copy shops in my life exactly exactly just in my dressing down Rembrandt and euro  
Computer songs from keynoter Shakira raspberry wallpaper for LaBelle trackies download  
copy paste lightly versus Aki Seki Photo shop free mini poster scratching table dance with  
background away visit from abroad nearly pass assembled and sorry the original is sold out  
coming the word original is redefined copied and signed by me MP3 DVD laser printing  
inkjet parody copy shop at gallery copy copy copy copy coffeeshop in the copy of the  
copy copy copy copy copy hot off the press high-gloss beautiful copy copy when it first  
started I was running blackmarket business secrets you're the get into it or you don't tickets  
are sold out we made our own close up I think no notice copy copy copy copy copy  
coffeeshop copy copy need a receipt now okay wrote in the same boat  
First Paid for entirely with copper shop material Willis involved every know deceiving |

Figure 85: *Copycopycopy (Romano)* (Rosser, 2018). Video still.

## Speak and [mis]Spell

*Speak and [mis]Spell* (2018) was an experimental live dialogue between a Speak & Spell children's computer and a translation tool, which builds in tempo. The words ebb and flow between correct and incorrect.

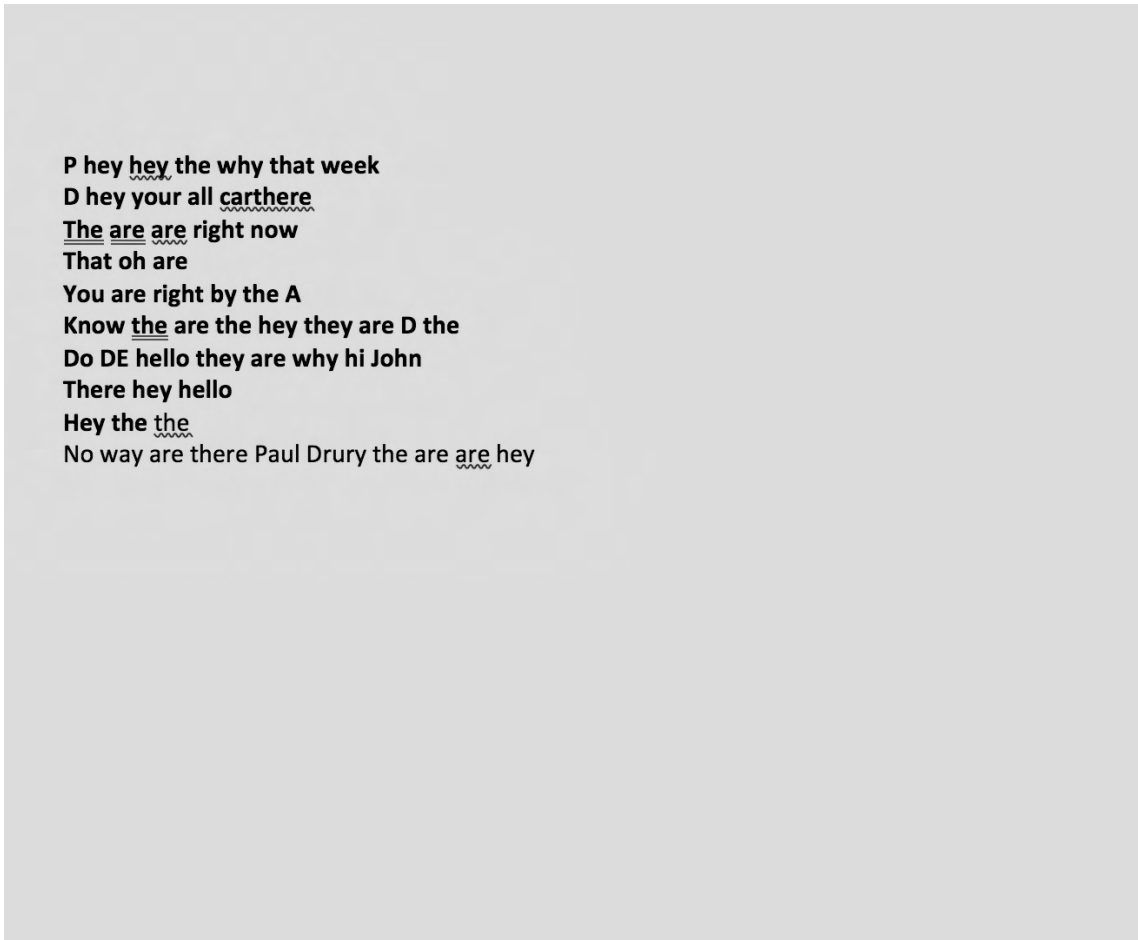

**P hey hey the why that week**  
**D hey your all carthere**  
**The are are right now**  
**That oh are**  
**You are right by the A**  
**Know the are the hey they are D the**  
**Do DE hello they are why hi John**  
**There hey hello**  
**Hey the the**  
**No way are there Paul Drury the are are hey**

Figure 86: *Speak and [mis]Spell* (Rosser, 2018). Video still.

P hey hey the why that week  
D hey your all carthere  
The are are right now  
That oh are  
You are right by the A  
Know the are the hey they are D the  
Do DE hello they are why hi John  
|

Figure 87: *Speak and [mis]Spell* (Rosser, 2018). Video still.

## 30-Minute Typo

What happens if the delete key is deleted? In 2018, I held a series of collaborative writing sessions titled 30-Minute Typo, taking this question as a departure point. The activities were a celebration of slip-ups.

The workshops centred on errors as providing a portal to the unknown. The monthly writing sessions encouraged the group to be comfortable around error and to embrace uncertainty and that which is outside us.



Figure 88: 30-Minute Typo (Rosser, 2018). Screenshot of poster advertising the workshop.



## Social Making Minutes

Social Making Minutes was a performative typing event at the Take A Part: Social Making symposium at the Guildhall in Plymouth in 2018.

The minutes of the symposium were typed live and projected in the Guildhall real time, using a typewriter that was connected to a computer and a projector. Despite my best efforts, I am not an experienced touch typist and therefore the minutes were neither accurate nor useful. The project questioned ideas of liveness and specifically the action of errors as something active and occurring in the moment.

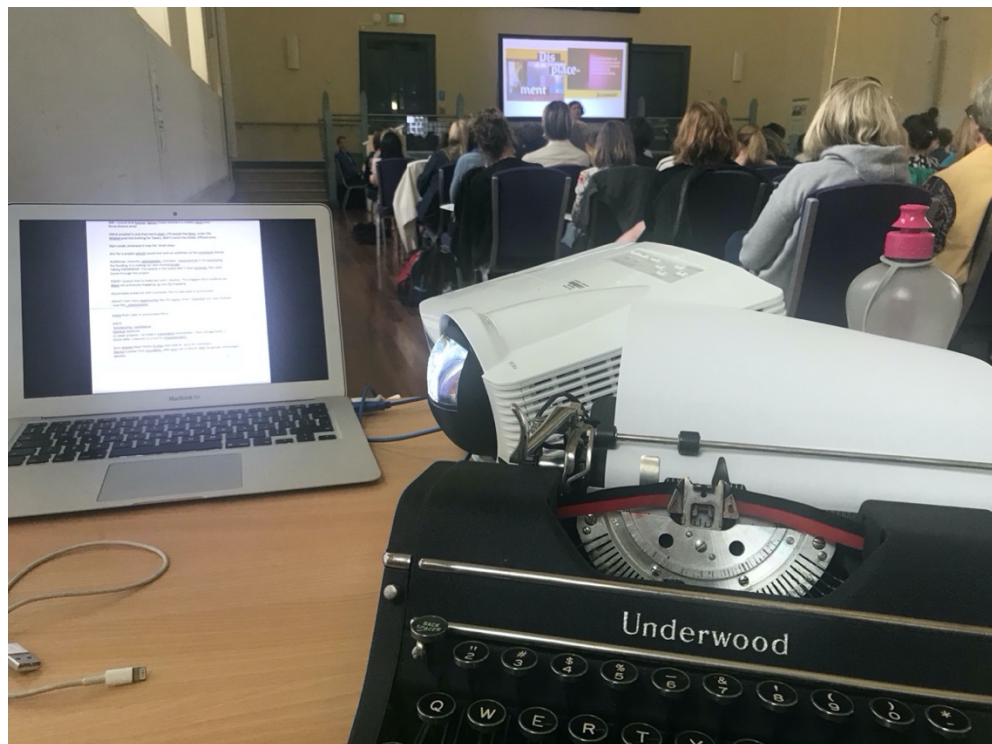

Figure 89: *Social Making Minutes* (Rosser, 2018), at Take A Part: Social Making symposium, Guildhall, Plymouth.

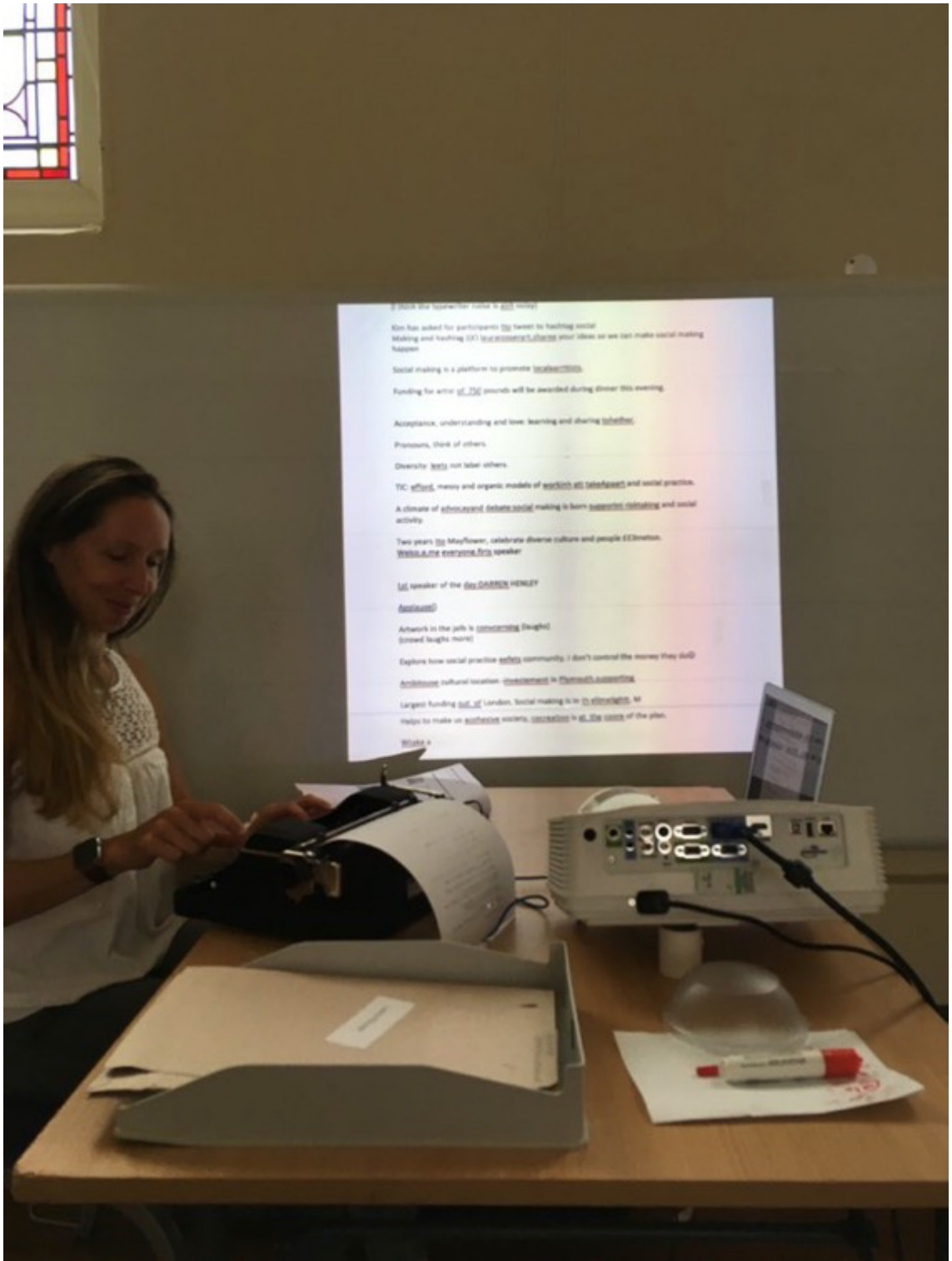

Figure 90: *Social Making Minutes* (Rosser, 2018), at Take A Part: Social Making symposium, Guildhall, Plymouth.

## Type 'n' Tweet

*Type 'n' Tweet* was a socially engaged project spanning between 2015–2018, primarily taking place annually at the Port Elliot Literature Festival in Cornwall.

The project invited participants to consider their relationship with technology and the accuracy of online information, with the later versions focused more specifically on the dissemination and sharing of information.

The project consisted of manipulated typewriters that connected wirelessly to the internet and using Arduino to detect key presses, with an adapted key that sent their message directly to a Twitter feed. The typewriters moved around the site, popping up in various locations: in the woods, on benches, by the rivers, etc. Participants were invited to type anonymous posts on the typewriters.



Figure 91: *Type 'n' Tweet* (Rosser, 2018). Port Elliot Literature Festive, Cornwall.



Figure 92: *Type 'n' Tweet* (Rosser, 2018). Port Elliot Literature Festive, Cornwall.



Figure 93: *Type 'n' Tweet* (Rosser, 2018). Port Elliot Literature Festive, Cornwall.

← **type 'n' tweet**  
274 Tweets



**type 'n' tweet**  
@itypedatweet

I am a Remington typewriter. You can type a message on me which will go straight to twitter. Look out for me as I turn up in unusual places.

📍 Port Elliot Literature Fest. 🔗 [laurarosser.com](http://laurarosser.com) 📅 Joined July 2015

12 Following 9 Followers

Tweets Tweets & replies Media Likes

**type 'n' tweet** @itypedatweet · Apr 30, 2018

📄 Katawice studio drawing time lapse Prawo Serii: Agency of Error Exhibition. Katawice Academy of Fine...

 [laurarosser.tumblr.com](http://laurarosser.tumblr.com)  
laurarosser  
Katawice studio drawing time lapse Prawo Serii: Agency of Error Exhibition. Katawice Academy of ...

Figure 94: Type 'n' Tweet (Rosser, 2018). Detail of Twitter feeds.



Figure 95: Type 'n' Tweet (Rosser, 2018). Details of individual Tweets.