

2022-01-01

Resilient Placement of VNFs and Distributed MANO Components in a WMN-based NFV Infrastructure

Frick, G

<http://hdl.handle.net/10026.1/19865>

Mobilkommunikation: Technologien und Anwendungen - 26. ITG-Fachtagung

All content in PEARL is protected by copyright law. Author manuscripts are made available in accordance with publisher policies. Please cite only the published version using the details provided on the item record or document. In the absence of an open licence (e.g. Creative Commons), permissions for further reuse of content should be sought from the publisher or author.

Resilient Placement of VNFs and Distributed MANO Components in a WMN-based NFV Infrastructure

Gregor Frick^{1,2}, Ulrich Trick¹, Armin Lehmann¹, Bogdan Ghita²

¹Research Group for Telecommunication Networks, Frankfurt University of Applied Sciences, Frankfurt/Main, Germany

²Centre for Security, Communications and Network Research, University of Plymouth, Plymouth, United Kingdom
{frick, trick, lehmann}@e-technik.org, {gregor.frick, bogdan.ghita}@plymouth.ac.uk

Abstract—Wireless Multi-Radio Outdoor-Routers are building a Wireless Mesh Network (WMN), which is used as an emergency communication infrastructure in case a disaster destroyed the existing communication system. A dynamic service provisioning shall be achieved by integrating Network Function Virtualisation (NFV) into the network. A distributed management and orchestration (MANO), which operates in-band of the network, controls the NFV infrastructure (NFVI). The primary goal of the distributed MANO consists of improving the network resilience to changes affecting the NFVI, namely node and link failures. For this aspect, the position of the Virtual Network Functions (VNFs), implementing a functional service component, as well as the position of the components building the distributed MANO within the WMN-based NFVI is essential. For this purpose, this publication proposes a concept for the resilient placement of the VNFs and distributed MANO components required within the WMN-based NFVI. Furthermore, a mathematical model of the network and an Integer Linear Programming (ILP) based optimisation target for implementing the concept are proposed. The optimisation target considers the connectivity of NFVI-Nodes at the placement by preferring well-connected NFVI-Nodes and avoiding poorly-connected ones. If required due to limited hardware resources, priorities among the different kinds of network functions are considered. Multiple existing solvers are used on the optimisation target to evaluate their performance in terms of their required time for providing an optimal solution based on different network sizes.

Keywords—Resilience, NFV, Distributed MANO, WMN, Resilient Placement

I. INTRODUCTION

Wireless multi-radio outdoor-routers are building a Wireless Mesh Network (WMN), which is used as an emergency communication infrastructure for rescue-helpers and victims in case a disaster destroyed the existing communication system. The architecture of this WMN-based disaster network (see Figure 1) is based on a clustering concept as described in [1]. The concept defines a different WiFi channel for each cluster, with each cluster consisting of four routers and thus four network nodes. A high throughput WMN is achieved through this concept, which builds the basis for an IP-based communication. By integrating Network Functions Virtualisation (NFV) into the network, a dynamic service provisioning shall be achieved. For this aspect, the hardware resources of the routers are utilised to establish the required NFV infrastructure (NFVI), which is used for providing services and network functionalities by deploying corresponding virtual network functions (VNFs).

The resulting WMN-based NFVI is controlled by a distributed management and orchestration (MANO), as proposed in [2]. The MANO system is operating in-band of the network and thus within the NFVI and not in a separate

management network as usual, making the WMN-based disaster network a stand-alone and autonomous network. For each NFVI-Node, and thus each network node, a Virtualised Infrastructure Manager (VIM) is defined which is responsible for managing and observing the hardware resources of the NFVI-Node. The VIMs are managed and orchestrated by Cluster-Orchestrators building the distributed orchestration. The distributed orchestration utilises the existing cluster structure of the network by assigning a Cluster-Orchestrator to each cluster of the network. Each Cluster-Orchestrator is thus responsible for orchestrating the resources in its assigned cluster via the corresponding VIMs. Through the synchronisation and communication between the existing Cluster-Orchestrators a network-wide orchestration is achieved.

The major task of the distributed MANO consists of improving and ensuring the resilience to changes and events affecting the network and its infrastructure, as stated in [3] and [4]. These changes and events are: the possibility of node failures due to the destruction of the nodes hardware resulting from events resulting from the environment of a disaster such as outbreaking fires or aftershocks; the possibility of link failures either resulting from node failures or long-lasting interferences making a link become unusable; the possibility of new outdoor-routers being added to the network to increase the geographical region of the network and thus requiring a properly integration of the hardware resources; the movement of users within the network. Regarding resilience, it is essential that the distributed MANO ensures the overall

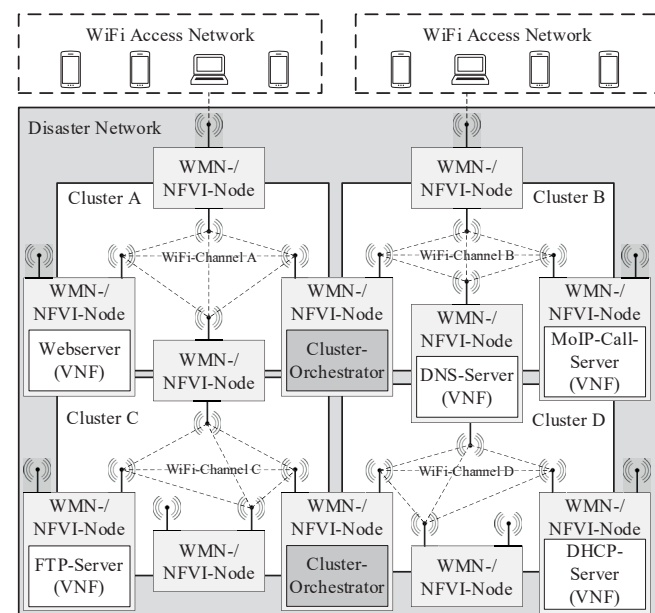

Figure 1 – Architecture of the WMN-based Disaster Network

usability of the network by ensuring the service availability and performance in the face of these changes and events.

While resilience can cover many different disciplines, as stated in [5], the major focus within this publication is on the resilient placement of the different network functions required in the network for providing the needed services. These network functions consist of the VNFs, implementing a functional service component (e.g., server implementations), and the Cluster-Orchestrators, building the distributed orchestration. The resilient placement concept defines the NFVI-Nodes responsible for providing a network function under the consideration of increasing the protection of the network function against node and link failures, as well as ensuring its individual performance aspect. An additional aspect covered by the concept consists of minimising the configuration effort that needs to be performed after a failure occurs. Through this, the possible impact of a node and/or link failure on the network infrastructure shall be decreased allowing a swift remediation of the failure impact and thus the recovery of the network.

This paper is structured as follows. Section II will examine existing related work regarding the resilient placement of NFV-MANO components as well as VNFs. The resilient placement of network functions within the WMN-based NFVI will be defined and presented in section III. A corresponding Integer Linear Programming (ILP) optimisation target is described in section IV, while Section V will evaluate the overall concept. The paper will close with a summary and outlook in section VI.

II. RELATED WORK

A. Resilient Placement of NFV-MANO Components

ETSI proposes resilience requirements for an NFV system, among others in [6]. These resilience requirements mainly deal with the resilience of VNFs and resilience processes and capabilities for the MANO to ensure the resilience of the NFV system. Specific requirements for the deployment of the NFV MANO components to ensure the resilience of the MANO itself are almost non-existent. The only indication is that the MANO should not have a single-point-of-failure and must enable a geo-distributed deployment. Within the WMN-based NFVI, this is already considered and ensured through the architecture for the distributed orchestration, as proposed in [2].

[7] investigates the dependability of an NFV orchestrator, which is a crucial characteristic for the orchestration to ensure the resilience of a network. However, the authors focus more on the capabilities of the NFV orchestrator (such as different monitoring schemes and fault management) than on the actual deployment of the MANO components. Same as ETSI, it is mentioned that the NFV orchestrator shall not provide a single-point-of-failure and should ensure a geo-distributed deployment. Comparable to the ETSI NFV references, the mentioned aspects are already considered by the architecture of the distributed MANO.

[8] is dealing with the allocation of NFVOs within a geo-distributed NFV system. This research considers a hierarchical NFV orchestration consisting of multiple Domain NFVOs and a centralised global service orchestrator, which has a fixed position within the network. The optimisation target consists of distinguishing the optimal number of required NFVOs within the system, the location of each

NFVO within their assigned domain, the number and location of each VNF Managers (VNFM) within the domains and the VNF instances assigned to each VNFM. The objective consists of minimising the number of required NFVOs and VNFMs while considering the capacity of the MANO components as well as delay constraints between the components of the MANO system. The research in [8] is introducing a degree of distribution of the MANO but is only focusing on the optimisation and reduction of operational cost of the MANO system within a large geo-distributed NFV system. During the placement of the MANO components, the possibility of node or link failures are not considered.

B. Resilient Placement of VNFs

The placement of VNFs is a large research field and has been surveyed among others in [9]. Therefore, a lot of research exist on the allocation of VNFs for a specific requirement such as quality of service aspects or other optimisation aspects such as the energy consumption. In the following, the major focus is on approaches that are dealing with the resilience of VNFs in terms of the possibility of failing nodes hosting a VNF.

The research in [10] and [11] are improving the resilience of Service Function Chains (SFCs) composed of multiple VNFs by introducing three different approaches: node protection, link protection and end-to-end protection. Node protection ensures redundant functions on other nodes, so that a node failure does not cause the SFC to stop. Link protection ensures multiple paths are existing between the functions so that a link failure does not cause the SFC to stop. While end-to-end protection is a combination of node protection and link protection. While this research focuses especially on SFCs, which are not utilised within the disaster network, the different protection schemes are also valid in case of the disaster network, making an adaptation reasonable.

In [12] resilience in terms of VNFs are summarised by covering different aspects such as the VNF failure management, the state management of stateful VNFs, the awareness of infrastructure resilience as well as the awareness of correlated failures. The research points out, that high availability can only be achieved by placing VNFs on multiple geo-distributed locations with a minimum of three data centres. Two node failures occurring in quick succession might in the worst-case result in the active VNF as well as its backup getting lost in a very short period. Having a second redundant instance could therefore reduce the probability of a complete service failure during the corrections of single node failures. An integration of this aspect into the WMN-based disaster network is conceivable since the possibility of two nodes failing in a quick succession does exist.

III. CONCEPT FOR A RESILIENT PLACEMENT OF NETWORK FUNCTIONS

To increase the general availability of the disaster network and its services, the resilience of the network against nodes and link failures needs to be improved. For this purpose, a concept for the resilient placement of network functions enabling the services is proposed. Two types of network functions are required to be placed within the WMN-based NFVI of the disaster network: VNFs and Cluster-Orchestrators. A VNF is implementing a functional service component, such as server implementations, while the Cluster-Orchestrators are building the distributed orchestration of the network as described in [2]. A network function is considered resilient if it is node- and link-protected

as well as individual performance aspects are met. These three aspects are explained in the following in more detail, while a complete exemplary placement according to the concept is shown and explained afterwards.

A. Node-Protection

Node-protection ensures that a node failure does not cause the loss of the functionality provided by the network function. A commonly utilised approach also used in this concept consists of enforcing a geo-distributed redundant deployment.

To ensure node-protection for each VNF required within the network, two additional redundant instances are deployed, a primary and a secondary backup VNF. The initial VNF, further also called active VNF, is providing its functionality to the network. The primary and secondary backup VNFs are synchronising with the active VNF to ensure that essential information and data are also node-protected. If the active VNF fails due to a node failure, the primary backup VNF will be activated to maintain the required functionality and avoid an overall service unavailability. The secondary backup VNF ensures the availability of the VNF in case of the primary backup VNF also failing shortly after the active VNF failure.

For the node-protection of the Cluster-Orchestrators, a Backup-Cluster-Orchestrators is deployed for each Cluster-Orchestrator, which shall take over the responsibilities of the active instance in case of a failure. An additional redundant instance is not required since the architecture of the distributed orchestration is capable to compensate this scenario through the communication between the Cluster-Orchestrators.

B. Link-Protection

Link-Protection ensures that a link failure does not cause the network function to become unavailable due to the NFVI-Node becoming disconnected from the network. A link failure can take place either because of the result of a node failure or due to lasting interferences causing a link to become unusable. Based on this aspect, link-protection highly depends on the connectivity of the network infrastructure resulting from the current cluster configuration. It is thus important to analyse the infrastructure regarding its link-protection capability.

The link-protection capability of the WMN-based NFVI depends on the size of the WMN and the cluster structure resulting from the clustering algorithm described in [1], which needs to be evaluated. Each network node and thus NFVI-

Node is evaluated regarding its link-protection capability resulting from its cluster configuration and resulting links within each cluster. The output of the evaluation consists of a description of the resilience state of each node. The possible resilience states, which are explained in the following, are: fully-resilient, partially-resilient and non-resilient (see Figure 2). The evaluation of these states is performed continuously, resulting in the aspect that the state of a NFVI-Node might also change due to changes in the connectivity of the network resulting from either node failures, link failures or new nodes being integrated into the network.

A network node evaluated as fully-resilient NFVI-Node indicates that the node is properly integrated into the physical network infrastructure from a clustering perspective. The node is operating in two clusters, and thus in two WiFi channels, and has multiple neighbours in each cluster. A network function placed on such a fully-resilient NFVI-Node would not become unavailable if one of the channels is affected by a long-lasting interference, since the node would also be reachable and thus available via the non-interferent channel. Based on the concept of the WMN-based disaster network, a node cannot become better integrated than being fully-resilient making such nodes the best possible position for a network function.

A partially-resilient node is the second-best option for placing a network function. Partially-resilient NFVI-Nodes are impaired in terms of the desired cluster structure since they have less available wireless links in comparison to fully-resilient NFVI-Nodes. Due to this reason, their connectivity is more vulnerable to failures of neighbouring nodes and occurring interferences hampering the availability and performance of a network function provided by such NFVI-Nodes. However, it shall be pointed out that at the geographical border of the network, the nodes are always partially-resilient since they are only connected to a single cluster, as seen in Figure 2.

A non-resilient NFVI-Node is the worst option for deploying a network function in the WMN-based disaster network. These kinds of nodes are only operating in a single channel and only have up to two neighbouring nodes. A failure of a neighbouring node will significantly decrease the connectivity and increase the possibility of the node becoming disconnected from the network. A network function deployed on a non-resilient NFVI-Node might thus also become unavailable within the network.

C. Individual Performance Aspects

Enabling protection against node and link failures for a network function is pointless if it is not capable to provide its functionality to the network due to performance restrictions resulting from the wireless network infrastructure. Based on this, it needs to be ensured that a network function is placed in a network section which is suitable for its performance as exemplarily explained in the following.

Regarding the distributed MANO of the disaster network, the resilient placement concept must ensure the architecture of the distributed orchestration as proposed in [2] during the placement of the Cluster-Orchestrators. Each Cluster-Orchestrator must be placed within its assigned cluster to ensure its individual performance aspect. During the placement of VNFs their individual performance criterion must also be considered such as a position close to the end-users of the network to achieve a maximal bandwidth.

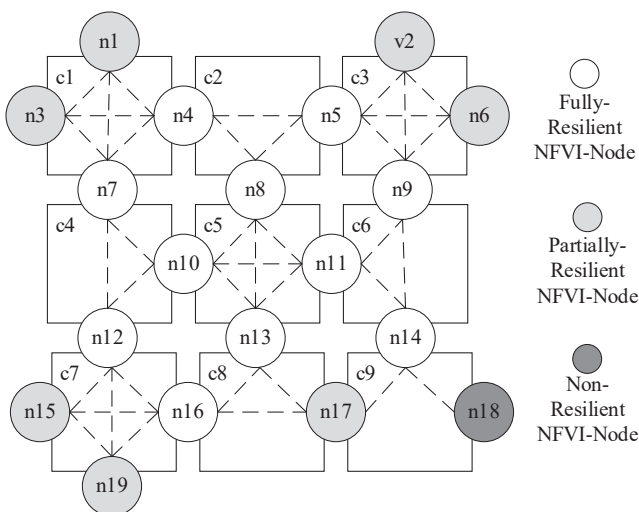

Figure 2 – Output of Link-Protection Evaluation

D. Prioritisation of Network Functions Instances

As a result of the node-protection concept, each network function consists of multiple instances: active and redundant backup instances. In the best-case scenario, each required instance can be deployed on a fully-resilient NFVI-Node. However, due to the structure and size of the network as well as the number of required network functions and resulting instances, this might not always be possible, because the number is exceeding the available capacity of fully-resilient NFVI-Nodes. For this situation, a network function instance prioritisation must be enforced. It ensures that higher prioritised instances are preferred at the placement and might therefore have an increased link-protection than lower prioritised instances. The different types of network function instances are prioritised as follows starting with the highest prioritisation to the lowest: Cluster-Orchestrators, active VNF, Backup-Cluster-Orchestrator, primary VNF backup, secondary VNF backup.

Cluster-Orchestrators are prioritised over other instances, as they are responsible for monitoring and controlling the NFVI. They are thus responsible for reacting to node and link failures in the first place by performing required emergency corrections, such as initialising a backup instance for ensuring the availability of the network function. Through the placement of Cluster-Orchestrators on fully-resilient NFVI-Nodes, they are capable to monitor their links and thus have the possibility to directly analyse the impact of detected link failures without the communication to other Cluster-Orchestrators or other distributed MANO components. This allows a swift reaction to a failure by remediating its impact. Active instances of a VNF are prioritised after the Cluster-Orchestrators since they are actively providing their functionality to the network. Ensuring an increased connectivity for those instances also ensures their protection against link failures and thus increases their availability. The prioritisation of the different types of redundant instances follows the concept of MANO component over VNF. This shall increase the possibility that after a failure of an active instance, the activated backup might already be placed on a suitable position for an active instance allowing the backup to become the new active instance. Through this, unnecessary relocations of instances shall be limited and thus reduce the required reconfigurations for resolving the impact of a failure.

E. Exemplary Output of the Resilience Placement Concept

Figure 3 shows an exemplary output of the resilient placement concept. For an improved understanding, it is considered that each network node and thus each NFVI-Node can provide up to two instances of network functions which shall represent the hardware limitations of the NFVI-Nodes. Within the network, five Cluster-Orchestrators (marked with CO) and three VNFs are placed according to the concept.

To ensure the required node-protection according to the concept, each network function is protected with the respective number of backups with a solid line representing this relationship in Figure 3. Each Cluster-Orchestrator is assigned a Backup-Cluster-Orchestrator (marked with B-CO), while each active VNF (marked with A) is assigned a primary and a secondary VNF instance (marked with B1 and B2).

The instances of the network function are placed according to their individual performance aspects, which are explained in the following. The Cluster-Orchestrators are allocated in their assigned clusters with the Backup-Cluster-Orchestrators

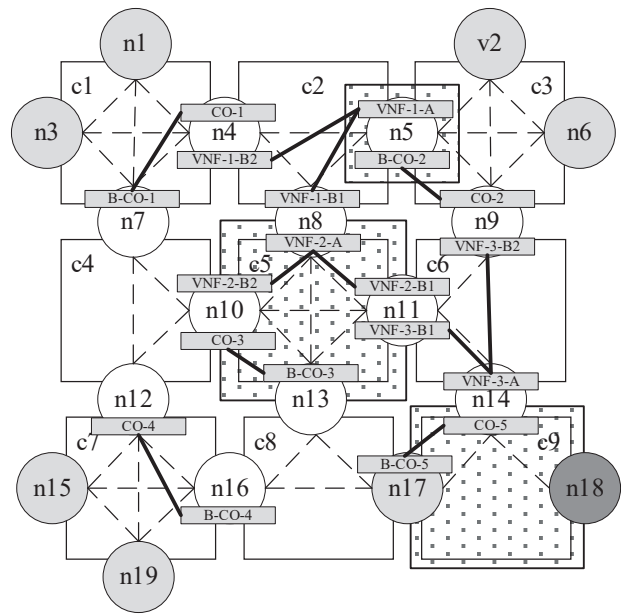

Figure 3 – Exemplary Network Configuration

also being placed in these clusters. The active components of VNF-1, VNF-2 and VNF-3 are placed close to positions of end-users of the network (marked with dotted areas in Figure 3). The backup instances of each VNF are placed close to the active instance to reduce the required synchronisation traffic between the different instances while ensuring the geo-distributed deployment.

Regarding link-protection the concepts enforced the deployment of instances on fully-resilient nodes as intended. Expect in cluster c9, the Backup-Cluster-Orchestrator is required to be allocated on a partially-resilient NFVI-Node resulting due to the lack of an additional fully-resilient placement opportunity within this cluster.

IV. MODEL AND OPTIMISATION TARGET FOR A RESILIENT PLACEMENT

A model has been prepared for solving the resilient placement in a WMN-based NFVI through an Integer Linear Programming (ILP) optimisation target. The model consists of N NFVI-Nodes, F network functions and I instances for each network function in F . The NFVI-Nodes N are representing the nodes in the network as NFVI-Nodes with $N = \{n_1, n_2, n_3, \dots, n_i\}$. The network functions F are representing the required Cluster-Orchestrators and VNFs within the network with $F = \{f_1, f_2, f_3, \dots, f_j\}$. The instances I are representing the required instances of a network function, namely active instance, and redundant backup instances, with $I_{f_j} = \{i_{j1}, i_{j2}, \dots, i_{jk}\}$.

The optimisation target is following a commonly used formularisation for ILP problems and consists of mapping all instances I of all network functions F to the NFVI-Nodes N under the consideration of maximising a resilience factor. The optimisation target and decision variable to be solved is formularised as follows in (1) and (2) respectively:

$$\text{Maximise } \sum_i^N \sum_j^F \sum_k^{I_j} \text{resilience}_{ijk} \times x_{ijk} \quad (1)$$

$$x_{ijk} = \begin{cases} 1 & \text{if } n_i \text{ is assigned with } i_{jk} \\ 0 & \text{otherwise} \end{cases} \quad (2)$$

The resilience factor in (3) depends on multiple aspects and is calculated for each possible combination of NFVI-Nodes N , network function F and instances I of the network:

$$resilience_{ijk} = lp_i \times pri_{ijk} \times suit_{ijk} \times alloc_{ijk} \quad (3)$$

The parameter lp_i in (4) represents the link-protection state of a NFVI-Node n_i as presented in section III and is defined as follows in (4):

$$lp_i = \begin{cases} 1 & \text{if } n_i \text{ is fully-resilient} \\ 0.5 & \text{if } n_i \text{ is partially-resilient} \\ 0.25 & \text{if } n_i \text{ is non-resilient} \end{cases} \quad (4)$$

Parameter pri_{ijk} represents the priority of an instances i_{jk} as described in section III and is defined as follows in (5):

$$pri_{ijk} = \begin{cases} 5 & \text{if } i_{jk} \text{ is active MANO} \\ 4 & \text{if } i_{jk} \text{ is active VNF} \\ 3 & \text{if } i_{jk} \text{ is passive MANO} \\ 2 & \text{if } i_{jk} \text{ is primary passive VNF} \\ 1 & \text{if } i_{jk} \text{ is secondary passive VNF} \end{cases} \quad (5)$$

The parameter $suit_{ijk}$ in (6) defines if a NFVI-Node n_i is suitable for assigning and thus placing an instance i_{jk} of a network function f_j on it from a performance point of view. By utilising this parameter, a specific network section can be defined in prior which is suitable for the placement, such as NFVI-Nodes close to the end-users of the network. If this parameter is not explicitly defined, it is considered that a network function can be placed on any existing NFVI-Node.

$$suit_{ijk} = \begin{cases} 1 & \text{if } n_i \text{ is suitable for } i_{jk} \\ 0 & \text{otherwise} \end{cases} \quad (6)$$

After a node or link failure the optimisation target must be solved again to recover the network by adapting it to the new situation. In this scenario, already placed instances don't necessarily have to be changed in their position when it is still suitable in terms of the resilient placement concept. For this aspect the parameter $alloc_{ijk}$ is introduced in (7), which gives a minor bonus to the resilience factor of already placed instances. Through the usage of this parameter, unnecessary changes, such as migrating an instance from one fully-resilient NFVI-Node to another, are avoided. However, the parameter $alloc_{ijk}$ does not hamper the placement if an improvement in the resilience can be achieved, such as migrating an instance from a partially-resilient to a fully-resilient NFVI-Node.

$$alloc_{ijk} = \begin{cases} 1.5 & \text{if } i_{jk} \text{ is allocated on } n_i \\ 1 & \text{otherwise} \end{cases} \quad (7)$$

The optimisation target in (1) is subject to the following constraints, which are enforcing logical restrictions:

$$\sum_j^F \sum_k^{I_j} x_{ijk} \leq 2; \forall n \in N \quad (8)$$

$$\sum_i^N x_{ijk} = 1; \forall f \in F, \forall i \in I_f \quad (9)$$

$$\sum_k^{I_j} x_{ijk} = 1; \forall n \in N, \forall f \in F \quad (10)$$

The constraint in (8) is limiting the number of instances i_{jk} which can be assigned to a NFVI-Node n_i and thus avoids the overloading of the hardware resources of an NFVI-Node. Currently, it is considered that each NFVI-Node is capable of hosting two network function instances. This decision was made for the purpose of simplification and a later change to a more realistic approach by introducing a resource consumption factor is conceivable. The constraint in (9) is ensuring that each instance i_{jk} is assigned to exactly one NFVI-Node. Otherwise, each instance would be deployed multiple times due to the maximisation target of the ILP formalisation. Constraint (10) ensures the geo-distributed deployment by allowing each NFVI-Node to be assigned only one instance per network function. This avoids the scenario that a node failure might cause the loss of an active instance and its corresponding backup instance.

V. EVALUATION OF THE RESILIENT PLACEMENT CONCEPT

The resilient placement concept has been evaluated based on the performance of existing solvers and algorithms to solve the optimisation target and a functional evaluation of the concept at imposing node failures on the network.

A. Performance Evaluation of existing Solvers

The following well-known linear programming solvers have been used for the optimisation target: SCIP (Solving Constraint Integer Programs) [13], CBC (COIN-OR Branch-and-Cut Solver) [14], and CLP (COIN-OR Linear Programming Solver) [15]. The solvers were executed on a system with an Intel Core i7-9850H CPU. To evaluate the performance of the different solvers at solving the optimisation target (i.e., defining the placement of the different network function instances within the NFVI), the time required by the algorithms to solve it with their default configuration was used as a performance criterion. The time was measured for different network sizes, while for each network size, the number of network functions and thus resulting instances have been increased. The network functions have been increased stepwise starting from a minimal amount of required network functions within the network resulting from the instances building the distributed MANO (0% in Table 1), up to the hardware resources of each NFVI-Node being fully occupied by VNF instances (100% in Table 1). This process was conducted for the network sizes of 5x5 clusters (60 nodes), 10x10 clusters (220 nodes), 15x15 clusters (480 nodes) and 20x20 clusters (840 nodes). To ensure that the results of the solvers are comparable, it was made sure that the overall objective value of the solutions is identical at each iteration. The results are shown in Table 1.

The measured time clearly shows that CLP is outperforming SCIP and CBC, making CLP the best choice for this optimisation target. Especially in larger networks (15x15 and 20x20 clusters), SCIP becomes unusable from the point of view that this calculation must be executed by a single Cluster-Orchestrator, which afterwards distributes the information to other Cluster-Orchestrators as intended by the concept of the distributed MANO. A specific reason for CLP outperforming the other solvers might consists of the aspect that it is especially designed for ILP optimisation tasks, while SCIP and CBC have a major focus on Mixed ILP problems.

B. Functional Evaluation of the Concept

For the functional evaluation, various network models with different amount of network functions were used. After

TABLE 1 MEASURED TIME REQUIRED BY SOLVERS TO SOLVE THE OPTIMISATION TARGET AT DIFFERENT NETWORK MODELS

| Network Size | Time [s] required by solver at an increasing amount of network functions respective to the maximal amount supported by network | | | | | | | | | | | | | | |
|--------------|--|-------|-------|-------|-------|-------|-------|-------|-------|-------|-------|-------|-------|-------|-------|
| | 0% | | | 25% | | | 50% | | | 75% | | | 100% | | |
| | SCIP | CBC | CLP | SCIP | CBC | CLP | SCIP | CBC | CLP | SCIP | CBC | CLP | SCIP | CBC | CLP |
| 5x5 | 0.037 | 0.042 | 0.006 | 0.09 | 0.073 | 0.007 | 0.219 | 0.115 | 0.012 | 0.35 | 0.157 | 0.02 | 0.50 | 0.193 | 0.027 |
| 10x10 | 0.259 | 0.514 | 0.043 | 3.045 | 0.937 | 0.075 | 13.35 | 1.547 | 0.126 | 28.51 | 1.988 | 0.239 | 35 | 2.556 | 0.328 |
| 15x15 | 1.119 | 3.468 | 0.226 | 60.54 | 5.977 | 0.488 | 167.1 | 9.506 | 0.789 | 338.2 | 14.32 | 1.29 | 573.6 | 19.44 | 2.775 |
| 20x20 | 2.856 | 11.45 | 0.588 | 345 | 22.73 | 1.416 | 1436 | 38.38 | 2.238 | 3481 | 56.7 | 3.93 | 6526 | 82.57 | 11.34 |

an initial execution of the optimisation target and thus the placement of the different instances of the network functions, single node failures were imposed on the network model and the optimisation target was solved an additional time. Based on the result of the new retrieved placement within the network, the required number of changes are distinguished to evaluate the concept regarding the minimisation of required configuration effort to resolve a node failure.

In most cases, it was observed that a simple redeployment of the failing instances resulting from the node failure is required, which is a logical result of a node failure and can thus be considered a minimal configuration effort to resolve the impact of a node failure. In a few cases, where the network was loaded due to an increased amount of additional VNFs, an additional configuration effort for resolving a node failure is observed. This occurs in situations where specific clusters are fully or close to being fully occupied in terms of existing hardware resources. Such a situation is visible in Figure 3 where each NFVI-Node of cluster c5 is assigned with instances. A node failure within this cluster might require existing instances to be migrated to other NFVI-Nodes to replace the failed instances of a network function. This aspect mostly results from the concepts instance prioritisation and needs to be further analysed in detail including a quantification of the resilience of the network infrastructure.

VI. SUMMARY AND OUTLOOK

Within a WMN-based NFVI, VNFs implementing a functional service component and Cluster-Orchestrators building the distributed MANO of the NFVI need to be placed. For this purpose, a placement concept was presented which improves the resilience of the network functions required in the network by ensuring their protection against node and link failures, which would hamper the availability of the network functions. The concept uses a geo-distributed deployment of redundant instances for each network function as well as an evaluation concept for rating the NFVI-Nodes according to their connectivity. By utilising this evaluation, the concept ensures the placement of network function instances on well-connected NFVI-Nodes while avoiding poorly-connected NFVI-Nodes, if possible, under the consideration of a prioritisation among the instances.

In addition, a corresponding ILP optimisation target has been defined based on the concept. Network models of different size were prepared for the optimisation target and solved via existing solvers showing that CLP has the best performance based on the time required to solve the optimisation target. In addition, a functional evaluation indicates that the concept is suitable for minimising the configuration effort required to resolve a node failure and corresponding link failures.

Since the concept for the resilient placement of network functions within a WMN-based NFVI is suitable for its

intended task, the concept will be further extended to support dynamic network aspects, which shall eliminate the requirement of defining suitable NFVI-Nodes for a network function instance in prior. For this aspect, the position of end-users, their demand for services as well as their traffic will be integrated into the optimisation target. Furthermore, the synchronisation traffic between the different instances of a network function as well as the automatic scaling of the distributed orchestration will be considered.

REFERENCES

- [1] A. P. Tchinda, G. Frick, U. Trick, A. Lehmann, and B. Ghita, "High Throughput WMN for the Communication in Disaster Scenario," in *2020 World Conference on Computing and Communication Technologies, WCCCT 2020*, 2020, pp. 53–63.
- [2] G. Frick, A. Lehmann, G. Frick, A. P. Tchinda, and B. Ghita, "Distributed NFV Orchestration in a WMN-Based Disaster Network," in *International Conference on Ubiquitous and Future Networks, ICUFN*, 2018, vol. 2018-July, pp. 168–173.
- [3] G. Frick, A. P. Tchinda, B. Shala, U. Trick, A. Lehmann, and B. Ghita, "Requirements for a Distributed NFV Orchestration in a WMN-Based Disaster Network," in *2019 International Conference on Information and Communication Technologies for Disaster Management*, 2019.
- [4] G. Frick, A. P. Tchinda, U. Trick, A. Lehmann, and B. Ghita, "Possible Challenges and Appropriate Measures for a Resilient WMN-Based Disaster Network," in *2020 World Conference on Computing and Communication Technologies, WCCCT 2020*, 2020, pp. 70–78.
- [5] E. K. Çetinkaya, A. Jabbar, J. P. Rohrer, M. Schöller, and P. Smith, "Resilience and survivability in communication networks: Strategies, principles, and survey of disciplines," *Comput. Networks*, vol. 54, no. 8, pp. 1245–1265, Jun. 2010.
- [6] ETSI, "Network Functions Virtualisation (NFV); Resiliency Requirements," *ETSI GS NFV-REL 001 V1.1.1*, 2015.
- [7] A. J. Gonzalez, G. Nencioni, A. Kamisinski, B. E. Helvik, and P. E. Heegaard, "Dependability of the NFV orchestrator: State of the art and research challenges," *IEEE Commun. Surv. Tutorials*, vol. 20, no. 4, pp. 3307–3329, Oct. 2018.
- [8] M. Abu-Lebdeh, D. Naboulsi, R. Glitho, and C. W. Tchouati, "NFV orchestrator placement for geo-distributed systems," in *2017 IEEE 16th International Symposium on Network Computing and Applications, NCA 2017*, 2017, vol. 2017-Janua, pp. 1–5.
- [9] S. Yang, F. Li, S. Trajanovski, R. Yahyapour, and X. Fu, "Recent Advances of Resource Allocation in Network Function Virtualization," *IEEE Trans. Parallel Distrib. Syst.*, vol. 32, no. 2, pp. 295–314, 2021.
- [10] A. Hmaity, M. Savi, F. Musumeci, M. Tornatore, and A. Pattavina, "Virtual Network Function placement for resilient Service Chain provisioning," in *Proceedings of 2016 8th International Workshop on Resilient Networks Design and Modeling*, 2016, pp. 245–252.
- [11] J. Kong *et al.*, "Guaranteed-Availability Network Function Virtualization with Network Protection and VNF Replication," in *2017 IEEE Global Communications Conference, GLOBECOM 2017 - Proceedings*, 2017, vol. 2018-January, pp. 1–6.
- [12] B. Han, V. Gopalakrishnan, G. Kathirvel, and A. Shaikh, "On the resiliency of virtual network functions," *IEEE Commun. Mag.*, vol. 55, no. 7, pp. 152–157, Jul. 2017.
- [13] G. Gamrath *et al.*, "The SCIP Optimization Suite 7.0," Zuse Institute Berlin, Mar. 2020.
- [14] J. Forrest *et al.*, "coin-or/Cbc: Release releases/2.10.7," Jan. 2022, doi: 10.5281/ZENODO.5904374.
- [15] J. Forrest *et al.*, "coin-or/Clp: Release releases/1.17.7," Jan. 2022, doi: 10.5281/ZENODO.5839302.