

2022-06-09

Updated diagnostic criteria and nomenclature for neurofibromatosis type 2 and schwannomatosis: An international consensus recommendation

Plotkin, SR

<http://hdl.handle.net/10026.1/19464>

10.1016/j.gim.2022.05.007

Genetics in Medicine

American College of Medical Genetics and Genomics

All content in PEARL is protected by copyright law. Author manuscripts are made available in accordance with publisher policies. Please cite only the published version using the details provided on the item record or document. In the absence of an open licence (e.g. Creative Commons), permissions for further reuse of content should be sought from the publisher or author.



ELSEVIER

ARTICLE

Updated diagnostic criteria and nomenclature for neurofibromatosis type 2 and schwannomatosis: An international consensus recommendation

Scott R. Plotkin^{1,*} , Ludwine Messiaen², Eric Legius³, Patrice Pancza⁴, Robert A. Avery⁵, Jaishri O. Blakeley⁶, Dusica Babovic-Vuksanovic⁷, Rosalie Ferner⁸, Michael J. Fisher⁹, Jan M. Friedman¹⁰, Marco Giovannini¹¹, David H. Gutmann¹², Clemens Oliver Hanemann¹³, Michel Kalamarides¹⁴, Hildegard Kehrer-Sawatzki¹⁵, Bruce R. Korf², Victor-Felix Mautner¹⁶, Mia MacCollin¹⁷, Laura Papi¹⁸, Katherine A. Rauen¹⁹, Vincent Riccardi²⁰, Elizabeth Schorry²¹, Miriam J. Smith²², Anat Stemmer-Rachamimov²³, David A. Stevenson²⁴, Nicole J. Ullrich²⁵, David Viskochil²⁶, Katharina Wimmer²⁷, Kaleb Yohay²⁸, International Consensus Group on Neurofibromatosis Diagnostic Criteria (I-NF-DC), Susan M. Huson²⁹, Pierre Wolkenstein³⁰, Dafydd Gareth Evans²²

ARTICLE INFO

Article history:

Received 19 September 2021

Received in revised form

23 April 2022

Accepted 9 May 2022

Available online xxxx

Keywords:

Iztr1

NF2

Neurofibromatosis

Schwannomatosis

SMARCB1

ABSTRACT

Purpose: Neurofibromatosis type 2 (NF2) and schwannomatosis (SWN) are genetically distinct tumor predisposition syndromes with overlapping phenotypes. We sought to update the diagnostic criteria for NF2 and SWN by incorporating recent advances in genetics, ophthalmology, neuropathology, and neuroimaging.

Methods: We used a multistep process, beginning with a Delphi method involving global disease experts and subsequently involving non-neurofibromatosis clinical experts, patients, and foundations/patient advocacy groups.

Results: We reached consensus on the minimal clinical and genetic criteria for diagnosing NF2 and SWN. These criteria incorporate mosaic forms of these conditions. In addition, we recommend updated nomenclature for these disorders to emphasize their phenotypic overlap and to minimize misdiagnosis with neurofibromatosis type 1.

Conclusion: The updated criteria for NF2 and SWN incorporate clinical features and genetic testing, with a focus on using molecular data to differentiate the 2 conditions. It is likely that continued refinement of these new criteria will be necessary as investigators study the diagnostic properties of the revised criteria and identify new genes associated with SWN. In the revised nomenclature, the term “neurofibromatosis 2” has been retired to improve diagnostic specificity.

© 2022 The Authors. Published by Elsevier Inc. on behalf of American College of Medical Genetics and Genomics. This is an open access article under the CC BY-NC-ND license (<http://creativecommons.org/licenses/by-nc-nd/4.0/>).

Scott R. Plotkin, Ludwine Messiaen, Eric Legius, Patrice Pancza, Susan M. Huson, Pierre Wolkenstein, and D. Gareth Evans contributed equally.

*Correspondence and requests for materials should be addressed to Scott R. Plotkin, Department of Neurology and Cancer Center, Massachusetts General Hospital, 55 Fruit Street, Boston, MA 02114. E-mail address: splotkin@mgh.harvard.edu

Affiliations are at the end of the document.

doi: <https://doi.org/10.1016/j.gim.2022.05.007>

1098-3600/© 2022 The Authors. Published by Elsevier Inc. on behalf of American College of Medical Genetics and Genomics. This is an open access article under the CC BY-NC-ND license (<http://creativecommons.org/licenses/by-nc-nd/4.0/>).

Introduction

Neurofibromatosis type 2 (NF2) is characterized by development of multiple benign nerve sheath tumors called schwannomas, particularly affecting the vestibular nerve.¹ Persons with NF2 usually present with bilateral vestibular schwannomas (VS) but can have schwannomas on other cranial, spinal, and peripheral/cutaneous nerves. Meningiomas are common with lifetime risks approaching 80%, whereas approximately 20% to 35% develop intramedullary spinal cord tumors (ependymomas).¹ The condition is also characterized by several ophthalmic features (lenticular opacities, retinal hamartoma, epiretinal membranes).

NF2 was first described by Wishart in 1822. After the reports of patients with type 1 neurofibromatosis (NF1) by von Recklinghausen (1882), various reports of NF2 around the turn of the 19th/20th century were conflated with NF1. In reality, the overlap between NF1 and NF2 should not be problematic for most clinicians. Only around 1% to 2% of NF2 patients have ≥ 6 café-au-lait macules,¹ and none of the other NF1 diagnostic criteria occur at increased rates in NF2.² In addition, some patients with schwannomatosis (SWN) are incorrectly diagnosed with NF1, typically because of misdiagnosis of schwannomas or hybrid nerve sheath tumors as neurofibromas. However, the main diagnostic difficulties are between NF2 and SWN, conditions that have significant phenotypic overlap.³ Two reports in 1996-1997^{4,5} provided convincing evidence for SWN as clinically distinct from NF2 by describing a group of mainly isolated patients, but occasional families that presented with noncranial, non-intradermal, painful schwannomas and no evidence of VS on imaging studies. Subsequently, germline variants in the *NF2* locus were excluded as the cause in some cases/families,⁶ which eventually led to the identification of *SMARCB1* as the cause in some SWN cases.⁷

The 2 main diagnostic criteria for NF2 date back to the National Institutes of Health consensus meeting in 1988⁸ and a United Kingdom study from 1992 (Supplemental Table 1).¹ Revisions to the UK Manchester criteria were published in 2019 replacing “glioma” with “ependymoma,” removing “neurofibroma,” creating an age limit of 70 years for development of VS, and introducing molecular criteria.³ The first SWN diagnostic criteria were published in 2005.⁹ These only required presence of ≥ 2 schwannomas (1 proven histologically) with exclusion of VS on magnetic resonance imaging (MRI) after age 18 years. Application of these criteria did not exclude individuals with NF2 who presented at a young age with non-VS.¹⁰ Furthermore, unilateral VS were subsequently shown to occur rarely in SWN,¹¹ leading to further modifications to the original criteria,¹² which finally included a molecular classification after the identification of *SMARCB1* as a cause for SWN.

Germline genetics of NF2 and SWN

Genetic variants are classified as benign (B), likely benign (LB), likely pathogenic (LP), pathogenic (P), or variant of

uncertain clinical significance (VUS) according to the standards and guidelines developed by the American College of Medical Genetics and Genomics, the Association for Molecular Pathology, and the College of American Pathologists.¹³ This framework offers the possibility of reclassifying variants as additional data become available such as moving a VUS into a LB or B or LP or P category or upgrading a variant from LP to P.

The *NF2* gene was cloned by 2 groups in 1993.^{14,15} Current genetic analysis typically includes next-generation sequencing (NGS) supplemented by multiplex ligation-dependent probe amplification to detect 1 exon to multiexon copy number changes and by high resolution karyotyping to identify chromosomal rearrangements such as a translocation interrupting the *NF2* locus that cannot be identified using NGS/multiplex ligation-dependent probe amplification,¹⁶ or ring chromosome 22q, particularly in de novo cases with severe learning disabilities.¹⁶ This approach has approximately 96% germline detection rate in the second generation of families with typical NF2 and bilateral VS.¹⁷ The lower detection rate in lymphocytes in de novo cases, particularly those with later onset and asymmetric presentation, is due to postzygotic mosaicism (Supplemental Figure 5).¹⁷ A recent study of >1000 de novo NF2 cases estimates that approximately 60% of these patients are mosaic.¹⁸ Tumorigenesis in NF2 occurs through a 2 hit model in which the first event is germline inactivation of *NF2* followed by a somatic inactivation of *NF2* in the trans allele.

At least 2 genes cause SWN.^{7,19} After the identification of *SMARCB1*,⁷ *LZTR1* was implicated in 2014,¹⁹ with both genes located centromeric to *NF2* on chromosome 22. Germline *SMARCB1* or *LZTR1* P variants (PVs) account for 70% to 80% of familial SWN, but only approximately 30% of sporadic cases.²⁰ RNA-based testing may improve sensitivity slightly for the detection of a PV in *SMARCB1* and *LZTR1*.²¹ Although patients with SWN do not harbor germline *NF2* PV, tumors frequently exhibit somatic PV of *NF2* and/or loss of the second *NF2* allele. A 3-step/4-hit hypothesis has been proposed for tumorigenesis in *SMARCB1*- and *LZTR1*-related SWN (Supplemental Figure 1A-B).²² These events result in biallelic inactivation of *SMARCB1* or *LZTR1* as well as biallelic *NF2* inactivation in tumors.

Important challenges persist for genetic testing of NF2 and SWN. First, 20% to 30% of patients with familial SWN lack germline PV in *SMARCB1* or *LZTR1* suggesting that additional SWN-causing genes likely exist. Second, molecular testing of blood in patients with sporadic SWN that meet diagnostic criteria often fails to reveal germline PVs for *SMARCB1* and *LZTR1*. Subsequent testing of 2 anatomically unrelated tumors identified identical *NF2* PVs in 37% to 57% of such individuals,^{23,24} thereby confirming mosaic NF2 (rather than SWN). These findings emphasize the need for testing blood and at least 2 tumors for genetic diagnosis, when possible.

With sponsorship from the Children’s Tumor Foundation (CTF), an international panel of neurofibromatosis (NF) and

SWN experts was assembled in 2017 and charged with reviewing the diagnostic criteria for NF1, NF2, and SWN. The work on NF1 was published recently.²

Materials and Methods

We used a common technique—a modified Delphi process—to reach consensus on revised diagnostic criteria, as previously described (Supplemental Figure 2).² A steering committee reviewed the literature, with disease experts meeting in New York (Supplemental Data 1), generated the statements for the 2 rounds of the Delphi process (Supplemental Data 2 and 3) regarding potential changes to diagnostic criteria for NF2 and SWN. Experts worldwide (Supplemental Data 4) responded to the Delphi questions. The steering committee actively sought input from medical experts outside of the NF field (Supplemental Data 5), patients, families, and advocates regarding the proposed criteria, and the new diagnostic criteria were finalized in January 2020.

Results

Development of initial proposals to revision of NF2 and SWN diagnostic criteria

The steering committee evaluated the literature for clinical and/or genetic features that could reliably identify and distinguish NF2, mosaic NF2, SWN, and mosaic SWN. Among the clinical features considered were presence of characteristic tumors in SWN, such as schwannomas (including intradermal), hybrid nerve sheath tumors, meningiomas, ependymomas, neurofibromas or gliomas; presence of ophthalmic features; and presence of a family history. Among the molecular features considered were identification of an *NF2*, *SMARCB1*, and *LZTR1* PV in tumor and unaffected tissue.

Modified Delphi process

In total, 56 of 76 NF experts who participated in the first Delphi process rated the 24 NF2/SWN diagnostic criteria statements (Supplemental Figure 3). There was very high consensus (median score = 10/10) for 4 proposed changes to the NF2 criteria: to update “glioma” with “spinal ependymoma,” to recommend molecular testing for individuals with multiple non-intradermal schwannomas, to specify the type of “cataract” to “juvenile cortical wedge cataract” or “presenile posterior lenticular opacity,” and to remove “neurofibroma” from the diagnostic criteria (Supplemental Figure 4). There was high consensus (median score = 7-9/10) for 5 proposed changes: clarifying which first-degree relatives meet criteria for family history, establishing an age limit to diagnose NF2 in individuals with only bilateral VS, creating formal criteria for diagnosis of mosaic NF2 in

the new criteria, creating the category “suspected NF2” in the revised criteria to recognize the phenotypic overlap with SWN, and adding “retinal hamartoma” as a nontumor criterion. There was no consensus (median score = 5/10) for 1 proposed change: to specify that meningiomas must be “nonmeningothelial meningiomas.”

For the SWN criteria, there was very high consensus (median score = 10/10) for 1 proposed change: requiring *NF2* testing in blood or in 2 separate anatomically unrelated tumors before considering a diagnosis of SWN (Supplemental Figure 4). There was high consensus (median score = 7-9/10) for 14 proposed changes: formally addressing nonpenetration of SWN, specifying the MRI protocol of the brain to exclude VS, specifying extent-of-disease evaluation in persons with germline *SMARCB1*/*LZTR1* PVs, creating the category “possible SWN” to recognize the phenotypic overlap with SWN, requiring imaging confirmation for suspected schwannomas, adding mosaic NF2 as an exclusion criterion, adding “spinal ependymoma” as an exclusion criterion, removing “intracranial meningioma” from the diagnostic criteria, adding molecular criterion for chromosome 22q-related SWN, clarifying the need for pathogenicity of *SMARCB1* and *LZTR1* variants in the criteria, clarifying which types of tumors induced by radiation cannot be used for diagnostic purposes, and including hybrid nerve sheath tumors into the diagnostic criteria. There was no consensus (median score = 5/10) for 1 proposed change: to modify the criteria to focus on differentiating SWN from NF1.

At the 2018 New York City meeting, working groups developed 19 revised statements for discussion (Supplemental Data 3). In total, 49 of 76 NF experts (64%) rated the 9 revised statements for NF2 and 10 revised statements for SWN (Supplemental Figure 4). There was very high consensus (>80% agreement) for all proposed changes to the NF2 diagnostic criteria: replacing “glioma” with “ependymoma;” removing “neurofibroma;” adding “retinal hamartoma” as a minor criterion, replacing “cataract” with “juvenile (diagnosed at age <40 years) subcortical and cortical wedge cataract;” adding “epiretinal membrane diagnosed at <40 years;” adding an *NF2* PV as a major criterion, retaining “2 or more meningiomas” as a major criterion, declining to add an age limit for diagnosing patients with bilateral VS, and replacing the Manchester criteria by a system of major and minor criteria.

For the SWN diagnostic criteria, there was very high consensus (>80% agreement) for all proposed changes: stating that molecular analysis is clinically indicated for all patients with suspected NF2/SWN; clarifying that schwannomas or hybrid nerve sheath tumors can be used for diagnosis of SWN; including detailed tables of molecular features of each condition into the diagnostic criteria (2 questions); clarifying that a PV alone in *NF2*, *SMARCB1*, and *LZTR1* is not sufficient for diagnosis of NF2/SWN; confirming that a diagnosis of SWN-not otherwise specified (NOS) can be established on the basis of clinical criteria alone; adopting the term “at risk for schwannomatosis” for individuals with (1) a

schwannoma or hybrid nerve sheath tumor and a first-degree relative with SWN-NOS, or (2) 2 or more schwannomas without pathologic confirmation; adopting the term “carrier” for asymptomatic individuals with germline PVs in *SMARCB1/LZTR1*. In total, 56 of 76 NF experts (74%) were involved in the revision process (Supplemental Data 4).

Of 12 (75%) non-NF specialists, 9 responded to the survey (Supplemental Data 5) and agreed that the proposed changes to the diagnostic criteria were reasonable. However, the experts had concerns that nonspecialists would find the diagnostic criteria difficult to use.

Revising the nomenclature of NF2 and SWN

The current diagnostic criteria for NF2 and SWN classify patients primarily on the basis of clinical features; however, it is now apparent that the phenotype of these diseases spans a continuum without absolute delineation of subtypes phenotypically. For this reason, we propose the umbrella term—schwannomatosis—in the updated criteria to reflect the overlapping clinical phenotype of these related conditions. Furthermore, we propose to classify the type of SWN according to the gene harboring a PV identified on molecular analysis. Thus, in the revised nomenclature, NF2 would be termed “NF2-related schwannomatosis” and SWN would be termed either “*SMARCB1*-related schwannomatosis” (for patients with germline PV in *SMARCB1*), “*LZTR1*-related schwannomatosis” (for patients with germline PV in *LZTR1*), “22q-related schwannomatosis” (for patients with multiple schwannomas with common molecular findings on chromosome 22q), “schwannomatosis-not otherwise specified (NOS)” (for patients who have clinical features of NF2/SWN but have not had molecular analysis), or “schwannomatosis-not elsewhere classified (NEC)” (for patients in whom molecular analysis of blood and tumors has failed to detect a PV). For this reason, a patient suspected of NF2 or SWN should have comprehensive molecular genetic testing, which may involve multiple tissues, including tumor tissue if available/possible.

Proposed new diagnostic criteria for NF2 and SWN

Ultimately, consensus was reached on the minimal clinical and genetic criteria for diagnosing NF2 and SWN (Figure 1). Final recommendations for diagnosis (along with pattern of genetic changes in unaffected and tumor tissue) for NF2-related SWN are listed in Table 1, for *SMARCB1*- and *LZTR1*-related SWN in Table 2, and for 22q-related SWN in Table 3. If genetic testing was not performed or is not available, a diagnosis of SWN-NOS can be made if the following criteria are met: (1) presence of 2 or more lesions on appropriate imaging consistent with non-intradermal schwannomas, and (2) pathologic confirmation of at least

1 schwannoma or hybrid nerve sheath tumor. Finally, a diagnosis of SWN-NEC can be made if the above 2 criteria are met and genetic testing of unaffected tissue and at least 2 anatomically distinct tumors does not reveal a PV in known SWN-related genes.

Mosaic NF2 and SWN Supplemental Figure 5

In the revised diagnostic criteria, mosaicism is confirmed by either of the following:

- Clearly <50% PV allele fraction in clinically unaffected tissue or
- PV not detected in clinically unaffected tissue but shared PV in ≥ 2 anatomically unrelated affected lesions

To ensure the consistency and quality of a diagnosis of mosaic NF2 and SWN, diagnostic laboratories must define and report their quantitative criteria for orthogonal confirmation of germline PVs vs genetic mosaicism.

Discussion

We describe the results of an international, multispecialty effort to update the diagnostic criteria for NF2 and SWN. The process extended over 3 years, and included a wide array of NF specialists, nonspecialists, patient advocacy groups, patients, and family members. The goal was to improve diagnostic accuracy by incorporating clinical and genetic discoveries made since the initial consensus conference. We used a modified Delphi approach to achieve a high level of consensus among stakeholders. One central challenge during the process was whether to rename NF2 and SWN. Specialists assert that changing the name NF2 will reduce misdiagnosis as NF1 and that an updated nomenclature will emphasize the clinical and genetic overlap between NF2 and SWN. In contrast, some patients and advocacy groups believe that changing these names will adversely affect patients’ identities and fundraising. Ultimately, the stakeholders decided to update the nomenclature for NF2 and SWN with the support of patient representatives and advocacy groups. The Delphi process worked well in both reaching consensus in some areas and highlighting the issues with varying opinions for discussion at the NYC New York City meeting.

Updated diagnostic criteria for NF2 and SWN

The most significant update to the diagnostic criteria for NF2 and SWN was incorporation of genetic criteria to supplement clinical criteria. Given the complexity of this topic, delineation of the genetic criteria has assumed a central role in the updated diagnostic criteria. We believe that these changes will help standardize the diagnostic

Genetic testing strategy for NF2 and SWN

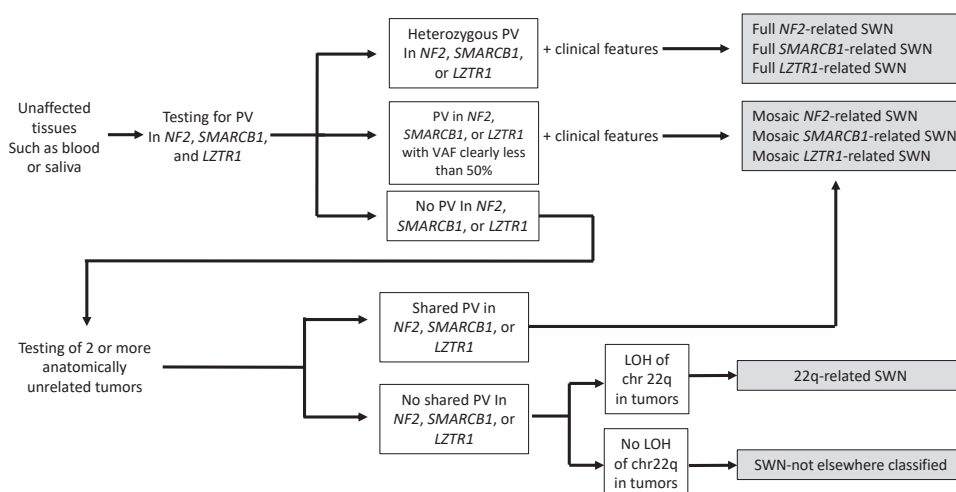

Figure 1 Schematic of genetic testing strategy for NF2 and SWN. LOH, loss of heterozygosity; NF2, neurofibromatosis type 2; PV, pathogenic variant; SWN, schwannomatosis; VAF, variant allele fraction.

process. For NF2, other updates include the use of major and minor criteria and clarification of key clinical features such as ependymoma, neurofibroma, epiretinal membranes,

and cataracts (Table 1). For SWN, clinical updates focus on incorporating the new histologic entity of hybrid nerve sheath tumors into the criteria.

Table 1 Revised diagnostic criteria for NF2-related schwannomatosis, formerly known as NF2

Diagnostic criteria for NF2-related schwannomatosis

A diagnosis of NF2-related schwannomatosis (previously termed neurofibromatosis 2, NF2) can be made when an individual has one of the following:

1. Bilateral vestibular schwannomas (VS)
2. An identical NF2 pathogenic variant in at least 2 anatomically distinct NF2-related tumors (schwannoma, meningioma, and/or ependymoma). (Note: if the variant allele fraction (VAF) in unaffected tissues such as blood is clearly <50%, the diagnosis is mosaic NF2-related schwannomatosis)
3. Either 2 major or 1 major and 2 minor criteria as described in the following:

Major criteria:

- Unilateral VS
- First-degree relative other than sibling with NF2-related schwannomatosis
- 2 or more meningiomas (Note: single meningioma qualifies as a minor criteria).
- NF2 pathogenic variant^a in an unaffected tissue such as blood (Note: if the VAF is clearly <50%, the diagnosis is mosaic NF2-related schwannomatosis)

Minor criteria:

Can count >1 of a type (eg, 2 distinct schwannomas would count as 2 minor criteria)

- Ependymoma, meningioma (Note: multiple meningiomas qualify as a major criteria), schwannoma (Note: if the major criterion is unilateral VS, at least 1 schwannoma must be dermal in location)

Can count only once (eg, bilateral cortical cataracts count as a single minor criterion)

- Juvenile subcapsular or cortical cataract, retinal hamartoma, epiretinal membrane in a person aged <40 years, meningioma

Pattern of genetic changes in unaffected and tumor tissue in NF2-related schwannomatosis

Gene locus Unaffected Tumor 1 Tumor 2 Comment
Tissue^b

Gene locus	Unaffected Tissue ^b	Tumor 1	Tumor 2	Comment
NF2				
Allele 1	PV1 ^c	PV1	PV1	Shared NF2 pathogenic variant
Allele 2	WT	LOH or NF2	LOH or NF2	Tumor-specific partial loss of 22q in trans position or a different NF2 somatic second PV
		PV2	PV3	in every anatomically unrelated tumor

LOH, loss of heterozygosity; NF2, neurofibromatosis type 2; PV, pathogenic variant; WT, wildtype.

^aIf a likely pathogenic variant is identified, tumor analysis may aid upward classification to pathogenic variant.

^bTissues unaffected by tumors such as blood or skin.

^cIf the variant allele fraction is clearly <50%, the diagnosis is mosaic NF2-related schwannomatosis.

Table 2 Revised diagnostic criteria for schwannomatosis with pathogenic *SMARCB1* or *LZTR1* variants

Diagnostic criteria for *SMARCB1*- and *LZTR1*-related schwannomatosis

A diagnosis of *SMARCB1*- or *LZTR1*-related schwannomatosis can be made when an individual meets 1 of the following criteria:

- At least 1 pathologically confirmed schwannoma or hybrid nerve sheath tumor and a *SMARCB1* (or *LZTR1*) pathogenic variant in an unaffected tissue such as blood^a
- A shared *SMARCB1* or *LZTR1* pathogenic variant in 2 schwannomas or hybrid nerve sheath tumors.

Pattern of genetic changes in unaffected and tumor tissue in *SMARCB1*- and *LZTR1*-related schwannomatosis^b

Gene locus	Unaffected Tissue ^c	Tumor 1	Tumor 2	Comment
<i>SMARCB1</i> / <i>LZTR1</i>				
Allele 1	PV1 ^d	PV1	PV1	Shared <i>SMARCB1</i> or <i>LZTR1</i> pathogenic variant
<i>NF2</i>				
Allele 1	WT	PV2	PV3	Tumor-specific pathogenic <i>NF2</i> variant in cis to pathogenic <i>SMARCB1</i> variant
Allele 2	WT	LOH	LOH	Tumor-specific partial loss of 22q in trans position, LOH typically entails deletion of 22q region encompassing <i>LZTR1</i> / <i>SMARCB1</i> / <i>NF2</i>

LOH, loss of heterozygosity; PV, pathogenic variant; WT, wildtype.

^aIf a likely pathogenic variant is identified, tumor analysis may aid upward classification to pathogenic variant.

^bSee also [Supplemental Figure 1A and B](#).

^cTissues unaffected by tumors such as blood or skin.

^dIf the variant allele fraction is clearly <50%, then the diagnosis is mosaic *SMARCB1*- or *LZTR1*-related schwannomatosis.

Assessing pathogenicity of variants

In the updated criteria, PVs represent an essential component of diagnosis, whereas variants that are B, LB, or of unknown significance cannot be used for diagnosis. Variants that are LP should have greater than 90% certainty to be disease causing. Given this small amount of uncertainty, the significance of LP variants for clinical diagnosis will need to be interpreted by the clinician along with other clinical and laboratory evidence. In a person with an LP variant and appropriate clinical features, a working diagnosis of “likely SWN” is reasonable. In these instances, study of relatives or the analysis of 2 anatomically unrelated tumors may allow for upgrading of the variant to P and confirm the diagnosis.

Classification of *LZTR1* variants poses a particular challenge owing to the fact that *LZTR1* exhibits loss-of-function tolerance.²⁵ Therefore, although loss-of-function is a common mechanism in *LZTR1*-related SWN, identification of a truncating *LZTR1* variant with no *NF2*/*SMARCB1* variant in an unaffected tissue such as blood of the patient with SWN does not confirm pathogenicity of the variant. Additional information that may support a classification as P includes either (1) that the prevalence of this truncating variant is clearly increased compared with controls (and we still do not yet have enough data on well-characterized patients with SWN to make such statistical confirmation), (2) that the variant has never been reported in controls and segregates with SWN in the family, which only can be verified in

Table 3 Revised diagnostic criteria for schwannomatosis in persons with no pathogenic variants in blood but with loss of chromosome 22q in multiple schwannomas

Diagnostic criteria for 22q-related schwannomatosis

A diagnosis of 22q-related schwannomatosis can be made when an individual does not meet criteria for *NF2*-related schwannomatosis, *SMARCB1*-related schwannomatosis, or *LZTR1*-related schwannomatosis, does not have a germline *DGCR8* pathogenic variant, and has both of the following molecular features:

- LOH of the same chromosome 22q markers in 2 anatomically distinct schwannomas or hybrid nerve sheath tumors and
- A different *NF2* pathogenic variant in each tumor, which cannot be detected in unaffected tissue

Pattern of genetic changes in unaffected and tumor tissue in 22q-related schwannomatosis^a

	Unaffected Tissue ^b	Tumor 1	Tumor 2	Comment
<i>SMARCB1</i> / <i>LZTR1</i>				
Allele 1	WT	None found	None found	No shared pathogenic <i>LZTR1</i> or <i>SMARCB1</i> variant
Allele 2	WT	LOH	LOH	Tumor-specific partial loss of the same chromosome 22q, LOH typically entails deletion of 22q region encompassing <i>LZTR1</i> / <i>SMARCB1</i> / <i>NF2</i>
<i>NF2</i>				
Allele 1	WT	PV1	PV2	Tumor-specific pathogenic <i>NF2</i> variant trans to the 22q deletion
Allele 2	WT	LOH	LOH	Tumor-specific partial loss of the same chromosome 22q, LOH typically entails deletion of 22q region encompassing <i>LZTR1</i> / <i>SMARCB1</i> / <i>NF2</i>

LOH, loss of heterozygosity; PV1, pathogenic variant; WT, wildtype.

^aSee also [Supplemental Figure 1C](#).

^bTissues unaffected by tumors, such as blood or skin.

familial cases, or (3) is proven de novo in a sporadic case with imaging confirmed absence of findings in both parents. In the absence of such evidence, *LZTR1* truncating variants will probably remain classified as LP. Analysis of the *NF2/SMARCB1/LZTR1* genes in 2 anatomically unrelated schwannomas with confirmation of retention of the *LZTR1* variant in the tumors, partial loss of 22q including *NF2/SMARCB1/LZTR1* in trans of the germline *LZTR1* variant, and a different *NF2* PV in both tumors could be considered as a new criterion supportive of the deleterious effect of the *LZTR1* variant, and may aid upward classification as P.

A Variant Curation Expert Panel for *NF1*, *NF2*, *SMARCB1*, and *LZTR1* under the auspices of the Clinical Genome Resource has recently been established (Principle Investigators: Elisabeth Castellanos and Scott Plotkin), tasked with refining classification criteria for these genes. The Variant Curation Expert Panel aims to assemble as many experts as possible, worldwide, to establish rules for interpretation and curation of variants in these genes. We expect the ability to classify variants correctly will improve over time, which is especially important for those variants currently classified as LP or of uncertain clinical significance.

Penetrance in *NF2*/SWN: Implications for SWN

NF2 is a fully penetrant disorder, meaning that any individual who carries a P *NF2* variant in all cells (ie, has a germline or constitutional *NF2* PV) will develop the clinical disorder, with average age of symptomatic onset of 22 years.¹ Therefore, offspring carrying the same P *NF2* variant as his/her affected parent, will develop the disorder.

In contrast, both *SMARCB1*- and *LZTR1*-related SWN exhibit incomplete penetrance based on unpublished evidence from the expert group. This means that a person with SWN carrying a *SMARCB1* or *LZTR1* (likely) PV may have relatives carrying the same genetic variant without any signs of SWN, even in adulthood. Although not all such relatives had an MRI to exclude occurrence of minor lesions, no clinical symptoms were present at advanced age in these apparently nonpenetrant relatives. The extent of incomplete penetrance in *SMARCB1* and *LZTR1* is not yet well-known but may be higher with *LZTR1* variants than *SMARCB1* variants. Furthermore, the reason for the incomplete penetrance is unclear, but may result from a time limitation owing to the need for multiple tumor events to occur for the development of schwannomas, eventually resulting in biallelic *NF2* loss, or may be caused by modifiers not yet identified.

Allelic disorders: Shared genetic loci with different clinical phenotypes

When *SMARCB1* was identified as the first SWN gene in 2007,⁷ it was already known since 1998 that P *SMARCB1* variants predispose to a different autosomal dominant (AD) genetic disorder with reportedly incomplete penetrance, ie, rhabdoid tumor predisposition syndrome (RTPS).²⁶

Subsequently, a genotype–phenotype correlation was observed. In patients with RTPS, germline *SMARCB1* PVs more likely affect exons 2 to 9 and are truncating (eg, one-to-multiple exon deletions). In patients with SWN, PVs are more likely nontruncating and occurring at the 5' or 3' end of the gene.²⁷ In 2012, yet another condition, Coffin–Siris syndrome, associated with distinctive craniofacial and skeletal abnormalities, central nervous system structural abnormalities, mild to severe intellectual disability, and speech delays were shown to be caused by likely dominant-negative or gain-of-function *SMARCB1* missense variants localized specifically at the C-terminal part of the protein, codons 363 to 377.²⁸ A total of 3 families have been reported with a truncating *SMARCB1* PV with affected members presenting with either rhabdoid tumors or SWN.²⁹ Another patient carrying a truncating *SMARCB1* variant developed SWN after surviving a rhabdoid tumor in childhood.³⁰ Furthermore, a patient diagnosed with Coffin–Siris syndrome in childhood and carrying a previously reported *SMARCB1* missense PV c.1121G>A, p.Arg374Gln, presented with SWN later in life.³¹ Based on current evidence, *SMARCB1* PVs can predispose to several allelic disorders: RTPS, SWN, or Coffin–Siris syndrome. Although the spectrum of *SMARCB1* PVs differs between these allelic disorders, overlap exists and has been reported.

LZTR1 poses similar challenges. *LZTR1* was initially identified in 2013 as a driver of glioblastoma tumorigenesis.³² In 2014, heterozygous germline loss-of-function *LZTR1* variants were reported to predispose to SWN,¹⁹ and confirmed as being the second major SWN locus.²⁴ The spectrum of phenotypes associated with *LZTR1* PVs further expanded by its association with both AD and autosomal recessive Noonan syndrome (NS) in 2015 and 2018.^{33,34}

Recent studies have started to elucidate the different genotypes associated with AD/autosomal recessive NS and SWN,^{34,35} although overlap exists. The *LZTR1* c.740G>A, p.S247N missense variant was found in a 2-generation family with NS, including a 53-year-old woman with NS and multiple schwannomas.³³ Co-occurrence of a familial P *LZTR1* germline variant was observed in a parent–child and a sibling–sibling pair within each family with 1 individual having SWN and 1 having glioblastoma.³⁶ An oligoastrocytoma was identified in a patient with NS who was *LZTR1*-positive with recurrence of the tumor as a ganglioglioma.³⁷

Why presence of PV is not stand-alone criterion for diagnosis

Because panel testing using NGS and exome/genome sequencing analysis has been ordered with increasing frequency in individuals with a variable set of clinical features possibly associated with an underlying genetic condition, some individuals have been identified carrying an *NF2/SMARCB1/LZTR1* variant (P, LP, or VUS) in blood, although *NF2* or SWN was not a suspected diagnosis.

Although *NF2*-related SWN is a fully penetrant disorder, a (L)P *NF2* variant identified using genome sequencing/exome sequencing in a sporadic individual with no *NF2*-related clinical features (eg, in an asymptomatic individual receiving genetic testing for another indication) should be further examined using orthogonal methods. Further testing should determine whether the variant is constitutional vs mosaic or somatic (eg, due to clonal expansion in hematopoietic stem cell/progenitor cells of indeterminate potential or secondary to therapy). A diagnosis of *NF2*-related SWN is, however, made in an asymptomatic individual carrying an *NF2* PV when inherited from a parent, thereby fulfilling diagnostic criteria.

Given the incomplete penetrance associated with *SMARCB1* and *LZTR1* PVs and the existence of allelic disorders, presence of incidental or secondary finding of an inactivating *SMARCB1* or *LZTR1* variant in an asymptomatic individual (eg, receiving genetic testing for another indication) cannot be used as a stand-alone criterion for diagnosis of SWN. Experts agreed that these patients should be referred to a center with special expertise in *NF2*/SWN for further clinical evaluation (including family members), genetic confirmation, and counseling. We anticipate that this recommendation—to avoid a diagnosis on the basis of the presence of a PV alone—will be reviewed in the future once more data becomes available. Consensus recommendations for management of unaffected persons with PV in *NF2*, *SMARCB1*, and *LZTR1* are not yet available but will be helpful in this population.

Identifying additional genes that cause SWN

A constitutional *NF2* PV can be identified in >95% of nonfounder patients with *NF2* with bilateral VS; a P or LP *SMARCB1* or *LZTR1* variant can be identified in approximately 60% to 70% of patients with familial SWN. Constitutional *SMARCB1*/*LZTR1* PV account for only approximately 30% of sporadic SWN cases, and mosaic *NF2* for a fraction of the remainder. Some *SMARCB1*/*LZTR1* PVs, missed by current diagnostic methods, may reside in untranslated regions or nearby regions that may affect expression (position effect).^{21,38} However, additional genes are likely to be discovered. For instance, a 3-generation family and an unrelated sporadic case with multiple schwannomas and multinodular goiter have now been described with the same *DGCR8* PV (c.1552G>A; p.E518K) on chromosome 22q that showed the same 3 event/4 hit mechanism as *SMARCB1*/*LZTR1* in 9 schwannomas, with 4 additional schwannomas showing somatic loss of the entire chromosome 22.³⁹ This finding should ideally be confirmed in more families; nevertheless, *DGCR8* is unlikely to be a major additional 22q-related SWN predisposition locus, because no additional *DGCR8* (L)PVs were identified by resequencing in 31 unrelated SWN cases negative for a constitutional first-hit *LZTR1*/*SMARCB1*/*NF2* PV.³⁸ Although 5 potential candidate

genes on chromosome 22q were proposed in the latter study, clear causal implications to disease could not be obtained.³⁸ However, it becomes unlikely that another single major locus resides on 22q; rather, there might be additional loci, each contributing to a small percentage of cases, with location not necessarily restricted to 22q.

Another previous report showed segregation of a missense variant in the chromosome 14 *COQ6* gene, but has not been corroborated since publication.⁴⁰ There is also evidence of rare families who develop schwannomas owing to loss of both p14 and p16 proteins usually from whole gene deletion of *CDKN2a* located on chromosome 9p.⁴¹ Further advances in the genetics of sporadic and familial SWN are needed.

Anticipated challenges

Clinical experts outside of the NF community expressed concern that the updated diagnostic criteria may be difficult to implement for some nonspecialists. These concerns stem from the challenges of interpreting PVs, evaluating incomplete penetrance, and ruling out allelic disorders. For this reason, CTF (a sponsor of this revision process) is creating an online tool to guide clinicians through the diagnosis of *NF2* and SWN (<https://www.ctf.org/understanding-nf/nf-criteria>). In cases of uncertainty, we recommend referral to specialty *NF*/SWN clinics for diagnosis.

We expect that these diagnostic criteria will be revised as investigators study the performance of the revised criteria and as additional SWN genes are identified. For this reason, CTF will sponsor an ongoing initiative to evaluate and recommend proposed changes to the diagnostic criteria. We anticipate that this group will meet periodically to solicit input from the community, to review data relevant to diagnostic criteria, and to publish consensus recommendations for use by the larger community.

Data Availability

The data from the modified Delphi process are available in [Supplemental Figures 2 to 4](#) and [Supplemental Data 1](#).

Acknowledgments

The authors would like to thank the Children's Tumor Foundation and Annette Bakker for supporting the revision process both financially and administratively. The authors would also like to thank the patients and foundations, particularly the members of the NF Collective for their attendance at informational webinars and for providing critical input. D.G.E. is supported by the NIHR Manchester Biomedical Research Centre (IS-BRC-1215-20007). S.R.P. is supported by NIH 5R01CA201130-04.

Author Information

Conceptualization: S.R.P., L.M., E.L., P.P., R.A.A., J.B., D.B.-V., R.F., M.J.F., J.M.F., M.G., D.H.G., C.O.H., M.K., H.K.-S., B.R.K., V.-F.M., M.M., L.P., K.A.R., V.R., E.S., M.J.S., A.S.-R., D.A.S., N.J.U., D.V., K.W., K.Y., I.N.F.D.C., S.M.H., P.W., D.G.E.; Data Curation: E.L.; Formal Analysis: E.L.; Funding Acquisition: P.P.; Investigation: E.L., L.M., P.W., S.M.H., D.G.E., S.R.P.; Methodology: E.L., L.M., P.W., S.M.H., D.G.E., S.R.P.; Project Administration: E.L., L.M., P.W., S.M.H., D.G.E., S.R.P., P.P.; Visualization: E.L., L.M., P.W., S.M.H., D.G.E., S.R.P.; Writing-original draft: E.L., L.M., P.W., S.M.H., D.G.E., S.R.P.; Writing-review and editing: S.R.P., L.M., E.L., P.P., R.A.A., J.B., D.B.-V., R.F., M.J.F., J.M.F., M.G., D.H.G., C.O.H., M.K., H.K.-S., B.R.K., V.-F.M., M.M., L.P., K.A.R., V.R., E.S., M.S., A.S.-R., D.A.S., N.J.U., D.V., K.W., K.Y., S.M.H., P.W., D.G.E.

Ethics Declaration

Not applicable.

Conflict of Interest

R.A.A., C.O.H., and K.A.R. declare no conflicts of interest. D.B.-V. is a scientific advisor for AstraZeneca, L.P. and receives grant support from the Department of Defense and SpringWorks Therapeutics. J.B. is a member of the Children's Tumor Foundation Medical Advisory Committee and the Clinical Care Advisory Board. D.G.E. is a member of the Children's Tumor Foundation Clinical Care Advisory Board-Europe and has received consultancy fees from AstraZeneca, SpringWorks Therapeutics, and Recursion. R.F. is a member of the Children's Tumor Foundation Clinical Care Advisory Board-Europe and is a medical advisor for AstraZeneca. M.J.F. is a member of the Children's Tumor Foundation Medical Advisory Committee. J.M.F. is a member of the Children's Tumor Foundation Clinical Care Advisory Board. M.G. receives grant support from NF2 Therapeutics, Inc and is a consultant for Puma Biotechnology. D.H.G. declares no conflicts of interest. M.K. is a paid consultant for Regeneron Pharmaceuticals. S.M.H. declares no conflicts of interest. H.K.-S. declares no conflicts of interest. B.R.K. is a member of the Children's Tumor Foundation Medical Advisory Committee (Chair) and is on the medical advisory boards of Genome Medicine and iNfixion Bioscience. E.L. is a member of the Children's Tumor Foundation Clinical Care Advisory Board-Europe. V.-F.M. is a member of the Children's Tumor Foundation Clinical Care Advisory Board-Europe. M.M. declares no conflicts of interest. L.P. declares no conflicts of interest. L.M. directed the Medical Genomics Laboratory at University of Alabama, Birmingham, which specializes in

genetic testing for all forms of the neurofibromatosis, until April 2021. P.P. is employed by the Children's Tumor Foundation. S.R.P. is a member of the Children's Tumor Foundation Clinical Care Advisory Board (Chair, United States) and Europe; is cofounder of NFlection Therapeutics, Inc and NF2 Therapeutics, Inc; and is a consultant for Akouos, AstraZeneca, and SonALASense. V.R. declares no conflicts of interest. E.S. is a member of the Children's Tumor Foundation Clinical Care Advisory Board and receives Department of Defense funding as a site for NF Clinical Trials Consortium. M.J.S. declares no conflicts of interest. A.S.-R. declares no conflicts of interest. D.A.S. is a consultant for Alexion Pharmaceuticals, Inc. N.J.U. is a member of the Children's Tumor Foundation Clinical Care Advisory Board, serves on the board of Neurofibromatosis Northeast, and received a consultant fee from AstraZeneca. D.V. is a member of the Children's Tumor Foundation Medical Advisory Committee and Clinical Care Advisory Board, is a member of the AstraZeneca speaker's bureau, and is on the Sanofi-Genzyme—MPS Board of Advisors. K.W. declares no conflicts of interest. P.W. is a member of the Children's Tumor Foundation Clinical Care Advisory Board-Europe (Chair). K.Y. is a member of the Children's Tumor Foundation Clinical Care Advisory Board, received a consultant fee from AstraZeneca, is on the Scientific Advisory Board for iNfixion Bioscience, is member of the Programmatic Review Committee for the Department of Defense, Congressionally Directed Medical Research Program, and Neurofibromatosis Research Program.

Additional Information

The online version of this article (<https://doi.org/10.1016/j.gim.2022.05.007>) contains supplementary material, which is available to authorized users.

Affiliations

¹Department of Neurology and Cancer Center, Massachusetts General Hospital, Boston, MA; ²Department of Genetics, Heersink School of Medicine, University of Alabama at Birmingham, Birmingham, AL; ³Department of Human Genetics, Member of ERN GENTURIS, KU Leuven and University Hospital, Leuven, Belgium; ⁴Children's Tumor Foundation, New York, NY; ⁵Division of Ophthalmology, The Children's Hospital of Philadelphia, Philadelphia, PA; ⁶Comprehensive Neurofibromatosis Center, Johns Hopkins Medicine, The Johns Hopkins Hospital, Baltimore, MD; ⁷Department of Clinical Genomics, Mayo Clinic College of Medicine and Science, Rochester, MN; ⁸Neurology, Guy's and St. Thomas' Hospital and NHS Trust, London, United Kingdom; ⁹Division of Oncology, Children's Hospital of Philadelphia, Philadelphia, PA; ¹⁰Department of Medical Genetics, Faculty of Medicine, The University of British

Columbia, Vancouver, British Columbia, Canada; ¹¹Department of Head and Neck Surgery, David Geffen School of Medicine at UCLA and Jonsson Comprehensive Cancer Center (JCCC), University of California, Los Angeles, CA; ¹²Department of Neurology, Washington University School of Medicine in St. Louis, St. Louis, MO; ¹³Institute of Translational and Stratified Medicine, Peninsula Medical School, University of Plymouth, Plymouth, United Kingdom; ¹⁴Department of Neurosurgery, Hospital Pitie-Salpetriere, Sorbonne Université, Paris, France; ¹⁵Institute of Human Genetics, University of Ulm, Ulm, Germany; ¹⁶Department of Neurology, University Hospital of Hamburg-Eppendorf, Hamburg, Germany; ¹⁷Pediatric Neurology, Bend, OR; ¹⁸The Department of Experimental and Clinical, Medical Genetics Unit, Biomedical Sciences “Mario Serio,” University of Florence, Florence, Italy; ¹⁹Department of Pediatrics, University of California Davis, Sacramento, CA; ²⁰The Neurofibromatosis Institute, La Crescenta, CA; ²¹Medical Genetics, Cincinnati Children’s Hospital Medical Center, Cincinnati, OH; ²²Manchester Centre for Genomic Medicine, St Mary’s Hospital, Manchester Academic Health Sciences Centre (MAHSC), Member of ERN GENTURIS, Division of Evolution, Infection and Genomics, University of Manchester, Manchester, UK; ²³Department of Pathology, Massachusetts General Hospital, Boston, MA; ²⁴Division of Medical Genetics, Department of Pediatrics, Stanford University, Stanford, CA; ²⁵Department of Neurology, Boston Children’s Hospital, Boston, MA; ²⁶Medical Genetics, University of Utah, Salt Lake City, UT; ²⁷Institute of Human Genetics, Medical University of Innsbruck, Innsbruck, Austria; ²⁸Departments of Neurology and Pediatrics, NYU Langone Health, New York, NY; ²⁹Clinical Genetics, (Formerly) Manchester Center for Genomic Medicine, Manchester University Hospitals, Manchester University NHS Foundation Trust, Manchester, United Kingdom; ³⁰Service de Dermatologie, Assistance Publique-Hôpital Paris (AP-HP), Hôpital Henri-Mondor, UPEC, Créteil, France

Nonauthor Contributing Members of the International Consensus Group on Neurofibromatosis Diagnostic Criteria (I-NF-DC)

Monique Anten, Arthur Aylsworth, Diana Baralle, Sebastien Barbarot, Fred Barker II, Shay Ben-Shachar, Amanda Bergner, Didier Bessis, Ignacio Blanco, Catherine Cassiman, Patricia Ciavarelli, Maurizio Clementi, Thierry Frébourg, Alicia Gomes, Dorothy Halliday, Chris Hammond Helen Hanson Arvid Heiberg, Pascal Joly, Justin T. Jordan, Matthias Karajannis, Daniela Kroshinsky, Margarita Larralde, Conxi Lázaro, Lu Le, Michael Link, Robert Listerick, Conor Mallucci, Vanessa L. Merker, Christopher

Moertel, Amy Mueller, Joanne Ngeow, Rianne Oostenbrink, Roger Packer, Allyson Parry, Juha Peltonen, Dominique Pichard, Bruce Poppe, Nilton Rezende, Luiz Oswaldo Rodrigues, Tena Rosser, Martino Ruggieri, Eduard Serra, Verena Steinke-Lange, Stavros Michael Stivaros, Amy Taylor, Jaan Toelen, James Tonsgard, Eva Trevisson, Meena Upadhyaya, Ali Varan, Meredith Wilson, Hao Wu, Gelareh Zadeh.

References

1. Evans DG, Huson SM, Donnai D, et al. A clinical study of type 2 neurofibromatosis. *Q J Med.* 1992;84(304):603–618.
2. Legius E, Messiaen L, Wolkenstein P, et al. Revised diagnostic criteria for neurofibromatosis type 1 and Legius syndrome: an international consensus recommendation. *Genet Med.* 2021;23(8):1506–1513. <http://doi.org/10.1038/s41436-021-01170-5>.
3. Evans DG, King AT, Bowers NL, et al. Identifying the deficiencies of current diagnostic criteria for neurofibromatosis 2 using databases of 2777 individuals with molecular testing. *Genet Med.* 2019;21(7):1525–1533. <http://doi.org/10.1038/s41436-018-0384-y>.
4. Wolkenstein P, Benchikhi H, Zeller J, Wechsler J, Revuz J. Schwannomatosis: a clinical entity distinct from neurofibromatosis type 2. *Dermatology.* 1997;195(3):228–231. <http://doi.org/10.1159/000245948>.
5. MacCollin M, Woodfin W, Kronn D, Short MP. Schwannomatosis: a clinical and pathologic study. *Neurology.* 1996;46(4):1072–1079. <http://doi.org/10.1212/wnl.46.4.1072>.
6. MacCollin M, Willett C, Heinrich B, et al. Familial schwannomatosis: exclusion of the NF2 locus as the germline event. *Neurology.* 2003;60(12):1968–1974. <http://doi.org/10.1212/01.wnl.0000070184.08740.e0>.
7. Hulsebos TJ, Plomp AS, Wolterman RA, Robanus-Maandag EC, Baas F, Wesseling P. Germline mutation of INI1/SMARCB1 in familial schwannomatosis. *Am J Hum Genet.* 2007;80(4):805–810. <http://doi.org/10.1086/513207>.
8. Neurofibromatosis. Conference statement. National Institutes of Health Consensus Development Conference. *Arch Neurol.* 1988;45(5):575–578.
9. MacCollin M, Chiocca EA, Evans DG, et al. Diagnostic criteria for schwannomatosis. *Neurology.* 2005;64(11):1838–1845. <http://doi.org/10.1212/01.WNL.0000163982.78900.AD>.
10. Baser ME, Friedman JM, Evans DG. Increasing the specificity of diagnostic criteria for schwannomatosis. *Neurology.* 2006;66(5):730–732. <http://doi.org/10.1212/01.wnl.0000201190.89751.41>.
11. Smith MJ, Kulkarni A, Rustad C, et al. Vestibular schwannomas occur in schwannomatosis and should not be considered an exclusion criterion for clinical diagnosis. *Am J Med Genet A.* 2012;158A(1):215–219. <http://doi.org/10.1002/ajmg.a.34376>.
12. Plotkin SR, Blakeley JO, Evans DG, et al. Update from the 2011 International Schwannomatosis Workshop: from genetics to diagnostic criteria. *Am J Med Genet A.* 2013;161A(3):405–416. <http://doi.org/10.1002/ajmg.a.35760>.
13. Richards S, Aziz N, Bale S, et al. Standards and guidelines for the interpretation of sequence variants: a joint consensus recommendation of the American College of Medical Genetics and Genomics and the Association for Molecular Pathology. *Genet Med.* 2015;17(5):405–424. <http://doi.org/10.1038/gim.2015.30>.
14. Trofatter JA, MacCollin MM, Rutter JL, et al. A novel moesin-, ezrin-, radixin-like gene is a candidate for the neurofibromatosis 2 tumor suppressor. *Cell.* 1993;72(5):791–800. Published correction appears in. *Cell.* 1993;75(4):826. [http://doi.org/10.1016/0092-8674\(93\)90406-g](http://doi.org/10.1016/0092-8674(93)90406-g).
15. Rouleau GA, Merel P, Lutchman M, et al. Alteration in a new gene encoding a putative membrane-organizing protein causes neurofibromatosis type 2. *Nature.* 1993;363(6429):515–521. <http://doi.org/10.1038/363515a0>.

16. Tsilchorozidou T, Menko FH, Lalloo F, et al. Constitutional rearrangements of chromosome 22 as a cause of neurofibromatosis 2. *J Med Genet.* 2004;41(7):529–534. <http://doi.org/10.1136/jmg.2003.016774>.
17. Evans DG, Wallace AJ, Wu CL, Trueman L, Ramsden RT, Strachan T. Somatic mosaicism: a common cause of classic disease in tumor-prone syndromes? Lessons from type 2 neurofibromatosis. *Am J Hum Genet.* 1998;63(3):727–736. <http://doi.org/10.1086/512074>.
18. Evans DG, Hartley CL, Smith PT, et al. Incidence of mosaicism in 1055 de novo NF2 cases: much higher than previous estimates with high utility of next-generation sequencing. *Genet Med.* 2020;22(1):53–59. <http://doi.org/10.1038/s41436-019-0598-7>.
19. Piotrowski A, Xie J, Liu YF, et al. Germline loss-of-function mutations in LZTR1 predispose to an inherited disorder of multiple schwannomas. *Nat Genet.* 2014;46(2):182–187. <http://doi.org/10.1038/ng.2855>.
20. Smith MJ, Isidor B, Beetz C, et al. Mutations in LZTR1 add to the complex heterogeneity of schwannomatosis. *Neurology.* 2015;84(2):141–147. <http://doi.org/10.1212/WNL.0000000000001129>.
21. Smith MJ, Bowers NL, Banks C, et al. A deep intronic SMARCB1 variant associated with schwannomatosis. *Clin Genet.* 2020;97(2):376–377. <http://doi.org/10.1111/cge.13637>.
22. Sestini R, Bacci C, Provenzano A, Genuardi M, Papi L. Evidence of a four-hit mechanism involving SMARCB1 and NF2 in schwannomatosis-associated schwannomas. *Hum Mutat.* 2008;29(2):227–231. <http://doi.org/10.1002/humu.20679>.
23. Evans DG, Bowers NL, Tobi S, et al. Schwannomatosis: a genetic and epidemiological study. *J Neurol Neurosurg Psychiatry.* 2018;89(11):1215–1219. <http://doi.org/10.1136/jnnp-2018-318538>.
24. Kehrer-Sawatzki H, Kluwe L, Friedrich RE, et al. Phenotypic and genotypic overlap between mosaic NF2 and schwannomatosis in patients with multiple non-intradermal schwannomas. *Hum Genet.* 2018;137(6-7):543–552. <http://doi.org/10.1007/s00439-018-1909-9>.
25. Lek M, Karczewski KJ, Minikel EV, et al. Analysis of protein-coding genetic variation in 60,706 humans. *Nature.* 2016;536(7616):285–291. <http://doi.org/10.1038/nature19057>.
26. Versteeg I, Sévenet N, Lange J, et al. Truncating mutations of hSNF5/INI1 in aggressive paediatric cancer. *Nature.* 1998;394(6689):203–206. <http://doi.org/10.1038/28212>.
27. Smith MJ, Wallace AJ, Bowers NL, Eaton H, Evans DG. SMARCB1 mutations in schwannomatosis and genotype correlations with rhabdoid tumors. *Cancer Genet.* 2014;207(9):373–378. <http://doi.org/10.1016/j.cancergen.2014.04.001>.
28. Tsurusaki Y, Okamoto N, Ohashi H, et al. Mutations affecting components of the SWI/SNF complex cause Coffin-Siris syndrome. *Nat Genet.* 2012;44(4):376–378. <http://doi.org/10.1038/ng.2219>.
29. Sredni ST, Tomita T. Rhabdoid tumor predisposition syndrome. *Pediatr Dev Pathol.* 2015;18(1):49–58. <http://doi.org/10.2350/14-07-1531-MISC.1>.
30. Kehrer-Sawatzki H, Kordes U, Seiffert S, et al. Co-occurrence of schwannomatosis and rhabdoid tumor predisposition syndrome 1. *Mol Genet Genomic Med.* 2018;6(4):627–637. <http://doi.org/10.1002/mgg3.412>.
31. Gossai N, Biegel JA, Messiaen L, Berry SA, Moertel CL. Report of a patient with a constitutional missense mutation in SMARCB1, Coffin-Siris phenotype, and schwannomatosis. *Am J Med Genet A.* 2015;167A(12):3186–3191. <http://doi.org/10.1002/ajmg.a.37356>.
32. Frattini V, Trifonov V, Chan JM, et al. The integrated landscape of driver genomic alterations in glioblastoma. *Nat Genet.* 2013;45(10):1141–1149. <http://doi.org/10.1038/ng.2734>.
33. Yamamoto GL, Agüena M, Gos M, et al. Rare variants in SOS2 and LZTR1 are associated with Noonan syndrome. *J Med Genet.* 2015;52(6):413–421. <http://doi.org/10.1136/jmedgenet-2015-103018>.
34. Johnston JJ, van der Smagt JJ, Rosenfeld JA, et al. Autosomal recessive Noonan syndrome associated with biallelic LZTR1 variants. *Genet Med.* 2018;20(10):1175–1185. <http://doi.org/10.1038/gim.2017.249>.
35. Umeki I, Niihori T, Abe T, et al. Delineation of LZTR1 mutation-positive patients with Noonan syndrome and identification of LZTR1 binding to RAF1-PPP1CB complexes. *Hum Genet.* 2019;138(1):21–35. <http://doi.org/10.1007/s00439-018-1951-7>.
36. Deiller C, Van-Gils J, Zordan C, et al. Coexistence of schwannomatosis and glioblastoma in two families. *Eur J Med Genet.* 2019;62(8):103680. <http://doi.org/10.1016/j.ejmg.2019.103680>.
37. Jacquinet A, Bonnard A, Capri Y, et al. Oligo-astrocytoma in LZTR1-related Noonan syndrome. *Eur J Med Genet.* 2020;63(1):103617. <http://doi.org/10.1016/j.ejmg.2019.01.007>.
38. Piotrowski A, Koczkowska M, Poplawski AB, et al. Targeted massively parallel sequencing of candidate regions on chromosome 22q predisposing to multiple schwannomas: an analysis of 51 individuals in a single-center experience. *Hum Mutat.* 2022;43(1):74–84. <http://doi.org/10.1002/humu.24294>.
39. Nogué C, Chong AS, Grau E, et al. DGCR8 and the six hit, three-step model of schwannomatosis. *Acta Neuropathol.* 2022;143(1):115–117. <http://doi.org/10.1007/s00401-021-02387-z>.
40. Zhang K, Lin JW, Wang J, et al. A germline missense mutation in COQ6 is associated with susceptibility to familial schwannomatosis. *Genet Med.* 2014;16(10):787–792. <http://doi.org/10.1038/gim.2014.39>.
41. Sargen MR, Merrill SL, Chu EY, Nathanson KL. CDKN2A mutations with p14 loss predisposing to multiple nerve sheath tumours, melanoma, dysplastic naevi and internal malignancies: a case series and review of the literature. *Br J Dermatol.* 2016;175(4):785–789. <http://doi.org/10.1111/bjd.14485>.