

2018

THE ROLE OF VIRTUAL IMAGING IN BUILDING CONSERVATION

SCHUETTE, KATHRIN

<http://hdl.handle.net/10026.1/13076>

<http://dx.doi.org/10.24382/440>

University of Plymouth

All content in PEARL is protected by copyright law. Author manuscripts are made available in accordance with publisher policies. Please cite only the published version using the details provided on the item record or document. In the absence of an open licence (e.g. Creative Commons), permissions for further reuse of content should be sought from the publisher or author.



UNIVERSITY OF PLYMOUTH

THE ROLE OF VIRTUAL IMAGING IN BUILDING CONSERVATION

by

KATHRIN SCHUETTE

A thesis submitted to Plymouth University
in partial fulfilment for the degree of

MASTER OF PHILOSOPHY

School of Arts, Design and Architecture

2018

UNIVERSITY OF PLYMOUTH

DRAKE CIRCUS, PLYMOUTH PL4 8AA

The Doctoral College January 2018

This copy of the thesis has been supplied on condition that anyone who consults it is understood to recognise that its copyright rests with its author and that no quotation from the thesis and no information derived from it may be published without the author's prior consent.

I. Acknowledgements

First, I would like to thank my supervisory team Linda Watson and Dr. Katharine Willis for their support and endurance. I would not have managed to write this research without them.

I would also like to say thank you to Dr. Hans Rohrmann, who gave me permission to use the Romanesque Portal from the St. Kastulus Münster in Moosburg an der Isar as one of my case studies.

Many thanks to Dr. Sebastian Ristow, who explained the process of creating the virtual reconstruction of the Aachen Cathedral. He was also kind enough to let me use some images of the virtual reconstruction created by ArchaeoPlanRistow, Köln (Sebastian Ristow`s company) and those he produced in collaboration with Narmer Architecture Studio, Budapest (Zsolt Vasáros, Gábor Nagy).

I also want to thank Dr. Bruce Induni, and Christa Gerdwilker as they have both motivated me and supported me so much.

Finally, thank you to Plymouth University for giving me the opportunity to write this research, and to my family and friends for their great support.

II. Author's Declaration

At no time during the registration for the degree of Research Masters has the author been registered for any other University award without prior agreement of the Doctoral College Quality Sub-Committee.

Work submitted for this research degree at the University of Plymouth has not formed part of any other degree either at the University of Plymouth or at another establishment.

An ethical approval form has been submitted and agreed by Plymouth University.

A programme of advanced study was undertaken, which included the taught modules MARE 521/ 523.

Relevant scientific seminars and conferences were attended, at which the usage of different techniques such as scanning, photogrammetry, but data collection and the exchange of data were also presented and discussed. The conferences focused on a variety of different professional fields, which are involved in cultural heritage such as art history, museums, architecture, archaeology and conservation. Between 2011 and 2017 there was rapid development in the field of virtual imaging and these events were important platforms for the exchange of information and ideas for the various professionals working within the area of cultural heritage.

Conferences Attended as a delegate:

2011, *Electronic Media and Visual Arts (EVA)*, Berlin, Germany;

2011, *Palladium Workshop*, Leuven, Belgium;

2012, *Electronic Media and Visual Arts (EVA)*, Berlin, Germany;

2013, *Digital Heritage*, Marseille, France;

2015, *Digital Heritage*, Granada, Spain;

2017, *CIPA Summer School, Heritage Documentation 2017*, Pafos, Cyprus;

2017 *CIPA Conference*, Ottawa, Canada.

Word count: 43.085

Signed.....

Date.....

Kathrin Schuette
The Role of Virtual Imaging in Building Conservation

III. Abstract

Conservation is the process of managing changes to significant historic buildings and places. This research explores key conservation concepts, identifying internationally agreed conservation principles and their relationship to the developing role of computer-based visualisation in the conservation process. An emphasis is placed upon documentation that plays an important part in conservation and has begun to recognise virtual imaging as a tool for recording, analysing, interpreting and presenting the cultural heritage. This research focuses in particular upon virtual imaging from the perspective of a building conservator. It addresses both the purpose and possibilities of virtual imaging, which are useful in terms of the act of conservation and more specifically regarding documentation, which itself informs and records the work of a conservator.

How can virtual imaging support the practice of the building conservation, with particular reference to documentation including recording and interpretation has been explored through considering the stages of the conservation process. To enable this examination a table has been created to address the question “Where, when and for what purpose an image is supportive in conservation” in relation to the conservation process. This has been informed by the Spinal Steps recommended by E.C.C.O. (The European Confederation of Conservator-Restorer’s Organisation). In addition, to better understanding the potential of this emerging technology different examples of virtual imaging and their uses have been assessed to help identify the benefits for imaging in

building conservation. To further investigate the impact of virtual imaging as a conservator's tool two case studies have been systematically examined to confirm its benefits and which stage of a conservation project they are of optimum use.

The overall outcome is that virtual imaging is of particular use to the conservator, and enhances the conservation process and management plan, particularly in terms of documentation and recording historic buildings.

Keywords: conservation management plan, conservation process, virtual imaging, documentation of cultural heritage, IT-based imaging in conservation.

IV. Preface

The author is a decorative stone and plaster conservator, who first trained as a stonemason and sculptor and later as a conservator in the field of architectural materials conservation. The author previously successfully completed the Architectural Materials Conservation course at Bournemouth University obtaining a degree of Master of Science. The author's professional career as a conservator started in England in 2002 and later worked in Scotland and Canada. Since 2007 the author has been working in Germany as a self-employed conservator, and currently works as a hands-on conservator specialising in stone and plaster. The author also works as a planner for building conservation work, which includes surveying the surfaces and creating a concept for the remit of the work before the process of conservation begins. Dealing on a daily base with questions such as how to present certain objects, the author determines what materials the best solution for are repairing and restoring certain types of decay. Finally, as a conservator, it is important to observe codes of ethics, including those controlled in Germany by "Denkmalämter".

In response to the huge changes in the types of technology that are now available to support and influence methods of conservation, the author has been involved in condition monitoring, 3D animation, dealing with engineered mortars and solvents and documentation with digital images. For example, the author was fortunate enough to have been involved in the generation of computer-animated images of historical objects from the Germanisches

National Museum, Nuernberg in Germany. Under the instruction of Sybille Herkner the author reconstructed a painted wooden sculpture of the Saint George (Heilige Georg), who fights a dragon, Potsdamer Stadtschloss (Castle of Potsdam, Germany). Sybille Herkner, who oversaw this work, had a contract to create 3-D models of different phases of the castle for a documentary film. Finally, the author also worked on a project involving articles from the 12th century from the portal at Kastulus Münster in Moosburg an der Isar, Germany, which is one of the case studies outlined in Chapter 4, between 2009-11. The challenge with this project was to virtually reconstruct the original surface and shape of these objects accordingly. The production of accurate images required cooperation with scientists, computer designers and technicians. This overlap of expertise with other professionals is vital in order to achieve a scientific result.

A good example of this is the 15th century wooden sculpture of “Heiliger Georg“, which is mentioned above. Most of the painted surface of this sculpture had been lost over the years but the research project, which the author was involved in, aimed to investigate the painted surfaces and patterns of the dress element of this sculpture and consider how to reconstruct the original ornamented appearance. Through collaboration between the “Germanisches National Museum” of Nuernberg, the University of Ansbach and the Otto Friedrich University of Bamberg the surfaces were eventually successfully virtually reconstructed.

The way that these IT-based technologies have been used within the research projects mentioned above and which the author was directly involved in have been pioneering within the field of conservation.

V. TABLE OF CONTENTS

| | |
|--|-----------|
| I. ACKNOWLEDGEMENTS | IV |
| II. AUTHOR'S DECLARATION | V |
| III. ABSTRACT | VII |
| IV. PREFACE | IX |
| V. TABLE OF CONTENTS | XI |
| VI. LIST OF FIGURES | XV |
| VII. LIST OF TABLES | XVII |
| VIII. ABBREVIATIONS AND ACRONYMS | XVIII |
| | |
| CHAPTER 1 – INTRODUCTION | 1 |
| 1. AN INTRODUCTION TO CONSERVATION | 1 |
| 1.1. IT TECHNOLOGY AND ITS USAGE IN CULTURAL HERITAGE | 2 |
| 1.2. THE TOPIC OF THE RESEARCH | 5 |
| 1.2.1. RESEARCH PROBLEM | 6 |
| 1.3. RESEARCH QUESTION | 7 |
| 1.4. RESEARCH AIM(S) AND OBJECTIVES | 7 |
| 1.5. HYPOTHESIS | 9 |
| 1.6. METHODOLOGY | 9 |
| 1.6.1. METHOD | 10 |
| 1.7. LITERATURE SOURCES | 13 |
| 1.7.1. KEY CONCEPTS | 15 |
| 1.7.2. RECONSTRUCTION, CONJECTURE, REPRODUCTION | 17 |
| 1.7.3. IT BASED CONSERVATION CHARTERS | 19 |
| 1.7.4. CONSERVATION PROCESS | 22 |
| 1.7.5. DOCUMENTATION AND RECORDING | 23 |
| 1.7.5.1 Time | 28 |
| 1.7.6. VIRTUAL IMAGING | 30 |

| | |
|---|-----------|
| 1.7.6.1 Devices | 33 |
| 1.7.6.2. Responsibility | 35 |
| 1.8. ANALYSIS AND DISCUSSION | 38 |
| 1.9. SUMMARY | 40 |
| | |
| CHAPTER 2 – CONSERVATION STRATEGY | 41 |
| | |
| 2. INTRODUCTION – CONSERVATION PROCESS AND THE ROLE OF THE CONSERVATOR | 41 |
| 2.1. CONSERVATION ETHICS AND PRINCIPLES: | 43 |
| 2.1.1. CULTURAL SIGNIFICANCE AND VALUE | 43 |
| 2.1.2. AUTHENTICITY, CONJECTURE WORK, RECONSTRUCTION | 47 |
| 2.1.3. RECORDING AND DOCUMENTATION | 52 |
| 2.1.3.1. Discussion | 54 |
| 2.1.4. RECORD – WHAT, WHEN AND WHY | 61 |
| 2.1.5. CONSERVATION PROCESS UK | 65 |
| 2.1.6. CONSERVATION PROCESS GERMANY | 70 |
| 2.1.7. COMPARISON BETWEEN UK AND GERMAN CONSERVATION GUIDELINES | 74 |
| 2.2. THE RELATIONSHIP BETWEEN THE CONSERVATOR AND THE CONSERVATION PROCESS | 75 |
| 2.2.1. COMPARING THE TABLES FROM HS, EH AND E.C.C:O | 79 |
| 2.2.2. A SUMMARY OF THE CONSERVATION PROCESS | 82 |
| 2.2.3. IMAGING WITHIN THE CONSERVATION PROCESS | 83 |
| 2.3. SUMMARY | 87 |
| 2.4. CONCLUSION | 88 |
| | |
| CHAPTER 3 – VIRTUAL AND DIGITAL MODELLING TECHNIQUES | 89 |
| | |
| 3. INTRODUCTION | 89 |
| | |
| 3.1. OVERVIEW OF IT BASED TECHNIQUES USED IN ARCHITECTURAL CONSERVATION | 90 |
| 3.1.1. WHEN IS VIRTUAL IMAGING APPROPRIATE? | 91 |
| 3.1.2. CAPTURING DATA | 94 |
| 3.1.2.1. GIS and BIM | 94 |
| 3.1.2.2. Photogrammetry | 100 |

| | |
|--|------------|
| 3.1.2.3. Software and Hardware | 107 |
| 3.1.3. CREATING AND SHARING DIGITAL IMAGE | 107 |
| 3.1.3.1. Introduction to creating virtual images | 111 |
| 3.2. WORKFLOW | 112 |
| 3.3. EXAMPLES OF THE USE OF VIRTUAL IMAGING | 115 |
| 3.3.1. VIRTUAL PRESENTATION OF ANCIENT HERITAGE | 119 |
| 3.3.1.1. Summary of examples 1 & 2 | 134 |
| 3.3.2. PHASE STUDY OF A HISTORIC BUILDING USING IT-BASED IMAGING | 136 |
| 3.3.2.1. Summary | 140 |
| 3.3.3. METRIC SURVEY | 142 |
| 3.3.3.1. Summary | 145 |
| 3.3.4. BIM AND SEMANTIC WEB TECHNOLOGY | 148 |
| 3.3.4.1. Summary | 152 |
| 3.3.5. PHOTOGRAMMETRY | 153 |
| 3.3.5.1. Summary | 154 |
| 3.4. CONCLUSION | 155 |
| | |
| CHAPTER 4 – CASE STUDIES | 158 |
| | |
| 4. INTRODUCTION | 158 |
| | |
| 4.1. CASE STUDY METHOD: | 162 |
| 4.1.1. SPECIALISTS IN THE CONSERVATION PROCESS | 165 |
| 4.1.2. THE CASE STUDY BUILDINGS | 167 |
| 4.1.3. SUMMARY | 174 |
| 4.2. CASE STUDY 1 – ST. KASTULUS MÜNSTER, MOOSBURG A.D.ISAR, GERMANY | 173 |
| 4.2.1. Stage 1 – capturing information about the object | 173 |
| 4.2.2. Stage 2 - analysis | 182 |
| 4.2.3. Stage 3 & stage 4 – diagnosis/ action plan | 186 |
| 4.2.4. Stage 5 - Conservation work | 189 |
| 4.2.5. Stage 6 – Documentation | 189 |
| 4.2.6. SUMMARY | 195 |
| 4.3. CASE STUDY 2 – AACHEN CATHEDRAL, GERMANY | 197 |
| 4.3.1. Stage 1 – capturing information about the object | 197 |
| 4.3.2. Stage 2 – analysis | 206 |

| | |
|---|------------|
| 4.3.3. Stage 3 and 4 – Diagnosis/ Action Plan | 211 |
| 4.3.4. Stage 5 – Conservation Work | 215 |
| 4.3.5. Stage 6 – Documentation | 216 |
| 4.3.6. SUMMARY | 220 |
| 4.4. DISCUSSION | 222 |
| 4.5. CONCLUSION | 225 |
| | |
| CHAPTER 5 - CONCLUSION | 227 |
| | |
| IX. GLOSSARY | XX |
| | |
| X. APPENDICES | |
| | |
| XI. BIBLIOGRAPHY | XXV |

VI. List of Figures

| | |
|---|-----|
| Figure 1: Ground plan St. Kastulus Cathedral | 12 |
| Figure 2: Ground plan of Aachener Cathedral | 13 |
| Figure 3: Lithography of the old castle Stuttgart, 1860 | 57 |
| Figure 4: Ground plan of the old castle Stuttgart, Germany | 58 |
| Figure 5: Photography of the castle after the 2. WW, around 1945 | 59 |
| Figure 6: Photography of the castle today | 60 |
| Figure 7: Appropriate levels of record | 63 |
| Figure 8: Diagram of the basic conservation activities – Historic Scotland | 67 |
| Figure 9: Stages in conservation-based research and analysis | 69 |
| Figure 10: Spinal Steps | 78 |
| Figure 11: THREE-DIMENSIONAL SURVEY TECHNIQUES | 98 |
| Figure 12: Laser Scanning Techniques | 99 |
| Figure 13: the vessel | 103 |
| Figure 14: screen-shot from Agisoft Photoscan Pro - image arrangement | 104 |
| Figure 15: screen-shot from Agisoft Photoscan Pro | 104 |
| Figure 16: screen-shot from Agisoft PhotoScan, alignment of the images | 106 |
| Figure 17: A typical laser scanning workflow | 113 |
| Figure 18: Excavations of the ancient city | 121 |
| Figure 19: physical Reconstruction of the gate | 122 |
| Figure 20: Istharr Gate in the museum Berlin | 123 |
| Figure 21: virtual reconstruction of the istharr gate | 124 |
| Figure 22: physical model of the gateway | 126 |
| Figure 23: physical model of the gateway | 127 |
| Figure 24: Drawn reconstruction: View of the Temple of DemeterSangri from south-east, with original painting | 130 |
| Figure 25: Temple of Demeter | 133 |
| Figure 26: Photorealistic Reconstruction “Temple of Demeter” | 133 |
| Figure 27: Merian engraving 1642 | 138 |
| Figure 28: Watercolour painting around 1750 | 138 |
| Figure 29: drawing around 1860 | 138 |
| Figure 30: Drawing around the end of 19 th century | 138 |
| Figure 31: photograph around end of 19 th century | 138 |

| | |
|---|-----|
| Figure 32: phase 1, CAD drawing..... | 139 |
| Figure 33: phase 2, CAD drawing | 139 |
| Figure 34: phase 3, CAD drawing..... | 139 |
| Figure 35: phase 4, CAD drawing..... | 139 |
| Figure 36: phase 5, CAD drawing..... | 139 |
| Figure 37: phase 6, CAD drawing..... | 139 |
| Figure 38: phase 7, CAD drawing..... | 139 |
| Figure 39: phase 7 minor extension, CAD drawing | 139 |
| Figure 40: Down House, England, reconstruction drawing | 141 |
| Figure 41: “The Cast Iron Bridge near Coalbrookdale” | 142 |
| Figure 42: Iron Bridge at Coalbrookdale, England..... | 144 |
| Figure 43: Iron Bridge – wire frame plotted from photogrammetry completed with TST. | 145 |
| Figure 44: Book Tower, Ghent, Belgium..... | 148 |
| Figure 45: linkage of information..... | 151 |
| Figure 46: reconstructed minaret of the Great Mosque, Aleppo..... | 153 |
| Figure 47: Photography of the portal | 168 |
| Figure 48: virtual imaging of the colour scheme | 169 |
| Figure 49: Sketch drawing of decorative details | 171 |
| Figure 50: Pillar plan, drawing based on photogrammetry | 172 |
| Figure 51: central Moosburg (1817-1841) | 175 |
| Figure 52: Hand drawing | 177 |
| Figure 53: Overview of the Romanesque Portal To St. Kastulus 1900/ 1940 | 179 |
| Figure 54: Detail Lions and Capitals..... | 180 |
| Figure 55: Mapping of the Portal..... | 183 |
| Figure 56: Close up of remaining paint | 192 |
| Figure 57: Cross section of paint flake | 192 |
| Figure 58: Mapping..... | 193 |
| Figure 59: Details of the Portal | 194 |
| Figure 60: section of Aachen | 198 |
| Figure 61: Palatine Chapel | 199 |
| Figure 62: a hypothetical model drawing of the “Pfalzgrafenanlage” | 202 |
| Figure 63: Ground plan of the Cathedral..... | 203 |
| Figure 64: unknown artist around 1622..... | 204 |
| Figure 65: Aachen Münster 1853..... | 205 |

| | |
|---|-----|
| Figure 66: Outside wall of the ruin Ruchenberg: Pietra Rasa with grout marks | 208 |
| Figure 67: example of one elevation of the material mapping | 210 |
| Figure 68: entire model of the Aachen cathedral Palatine Chapel and the Choir | 213 |
| Figure 69: ground plan of the northern basilica | 218 |
| Figure 70: vectorised CAD drawing | 218 |
| Figure 71: reconstruction | 219 |

VII. List of Tables

| | |
|---|-----|
| Table 1: Conservators work in relation to a conservation process | 86 |
| Table 2: Comparison of examples | 118 |
| Table 3: reflection of different techniques | 155 |
| Table 4: Case Study framework | 163 |
| Table 5: list of professionals and their role | 166 |
| Table 6: The Role of imaging in Stage 1 | 173 |
| Table 7: The Role of imaging in Stage 2 | 182 |
| Table 8: The Role of imaging in Stage 3 and 4 | 186 |
| Table 9: The Role of imaging in Stage 5 | 189 |
| Table 10: The Role of imaging in Stage 6 | 189 |
| Table 11: The Role of imaging in Stage 1 of Aachen Cathedral's Palatine Chapel's Conservation Project | 197 |
| Table 12: The Role of imaging in Stage 2 of Aachen Cathedral's Palatine Chapel's Conservation Project | 206 |
| Table 13: The Role of imaging in Stage 3 and Stage 4 of Aachen Cathedral's Palatine Chapel's Conservation Project | 211 |
| Table 14: The Role of imaging in Stage 5 of Aachen Cathedral's Palatine Chapel's Conservation Project | 215 |
| Table 15: The Role of imaging in Stage 6 of Aachen Cathedral's Palatine Chapel's Conservation Project | 216 |
| Table 16: The Role of imaging in Stage 1-6 of Aachen Cathedral's Palatine Chapel's Conservation Project | 220 |

VIII. Abbreviations and Acronyms

BIM – Building Information Modelling

CIPA – International Committee for Heritage Documentation

CoBRA - Conservation-based Research and Analysis

E.C.C.O – European Confederation of Conservator-Restorers` Organisations

ENCoRE - Paper on Education and Access to the Conservation-Restoration
Profession

EQF - European Qualifications Framework

GIS - Geographic Information System

ICOMOS – International Council on Monuments and Sites

ICCROM – International Centre for the Study of the Preservation and

Restoration of Cultural PropertyNPPF – National Planning Policy Framework

SfM – Structure from Motion

UNESCO - United Nations Educational, Scientific and Cultural Organisation

Chapter 1 – Introduction

This chapter includes a summary of conservation and of the rationale behind the choice of this particular topic. This is followed by a discussion around the development and use of IT technology in building conservation to provide a context for the research. This is followed by an introduction to the research topic, the associated problems a summary of the research question and an outline of the research aims and the objectives. The key concepts and themes are identified and introduced within the literature review and discussed in more depth later in the research.

1. An introduction to conservation

Cultural Heritage¹ is an important aspect of national identity and includes the protection of tangible and intangible heritage. It is the practice of instilling architecturally significant² buildings from the past to the present (ICOMOS Venice Charter, Preface). In the context of this research the focus is on historic buildings. Conservation³ is described as a way of managing the changes, which can affect significant historic buildings (Drury, 2008, p.72), and this requires an informed ethical approach, which is one of the most important requirements of the conservation process⁴ and needs careful consideration for each individual project. This chapter introduces the key concepts in conservation, relating to an

¹ Definition in Glossary

² Definition in Glossary

³ Definition in Glossary

⁴ Definition in Glossary

understanding of the significance of historic buildings and their values⁵ inherent cultural value.

The author, as a conservator, has been involved in different projects where IT-based technology has been a direct part of the conservation process. These experiences within this field have raised several questions for the author about the various pros and cons of data-based recording⁶ and documenting.⁷ As a result the author has been drawn to research that examines the use of IT-based technologies in the field of conservation work.

This particular research arose from a will to understand the capacity of these new IT-based methods that are currently being used in conservation, and to consider how these methods change the work of conservators and our understanding of conservation itself as a practice.

Due to the broad nature of the field of IT-based methods the decision was made to concentrate on virtual imaging and its role and application in building conservation, and in particular for its use in documentation.

1.1. IT technology⁸ and its usage in Cultural Heritage

Building conservation began to embrace the digital world at the end of the twentieth century (Messemer, H. 2016, p. 22-42). For instance, building surveyors now document buildings using techniques such as electronic distance measurements (EDM) for image-surveys and CAD, terrestrial laser scanning⁹

⁵ Definition in Glossary

⁶ Definition in Glossary

⁷ Definition in Glossary

⁸ a brief history of the development of IT technology can be found in Appendix 9

⁹ Definition in Glossary

and photogrammetry,¹⁰ in addition to the traditional methods for measuring and collecting data from the asset. With these techniques it is possible to create digital plans, drawings or even virtual images in order to understand the building in more detail. In the field of architecture, architects present their proposed intervention using IT-based technologies such as augmented reality or virtual imaging. In the field of archaeology, 3-D modelling explains how the assets might have worked or shows what they might have looked like in the past. Museums are also working more and more with augmented reality or 3-D models, providing experiences for the visitor such as interactive tours via the internet through either single exhibitions or sometimes the entire museum. Organisations such as the Historic Buildings and Monuments Commission for England (English Heritage / Historic England),¹¹ and Historic Environment Scotland (formerly Historic Scotland)¹² in Great Britain, monument offices (Landesdenkmalämter) and palace department (Schlösserverwaltung) in Germany are Government agencies founded for the protection of historic monuments. All these agencies are now promoting digital tools through their publications and projects. Considering the use of such digital tools within these agencies has allowed the author to further understand how these tools are currently being used within the field of conservation. By reviewing the literature associated with these projects, and critically appraising the techniques used in conjunction with material from other relevant scholarly literature the author has

¹⁰ Definition in Glossary

¹¹ Historic England was formed in 2015 to take on many of the functions of English Heritage. Both names are in use in this research.

¹² Historic Scotland is since 2015 a sub organisation under the main body called Historic Environment Scotland

been able to present a snapshot of digital imaging use within building conservation projects from across Europe. However, the literature on conservation and the digital world is limited as it is a developing field, so attending conferences for example; Electronic Media and Visual Arts (EVA) 2011, 2012, Berlin, Germany, Digital Heritage in Marseille and Granada (2013/2015), Palladium in Leuven (2011), Belgium and studying the associated research papers has been vital in understanding its potential.

There are several important international conservation charters, guidelines and principles associated with Cultural Heritage, which have been fundamental to the development of Cultural Heritage as a concept. For building conservation, there are two main documents to consider the Venice Charter (1964) and the Australia Burra Charter (2013). For IT-based technologies the London Charter (2013) and the Principles of Seville (2011) point out the potential but also the limitations of IT-based technologies.

The definition of virtual imaging and the virtual image is defined for this research by the author as a computer-based process, which involves the non-physical reconstruction of a phase or moment in time. It is a visual documentation tool, which also incorporates information about an object, building or place for instance historical information, future changes and interventions etc.

A Virtual Image is the actual digital reconstruction that incorporates the collected data relating to the chosen phase or moment in time.

To fully understand the potential of virtual imaging, and to critically assess its role and the implications of adopting these developing techniques, first requires an understanding of the conservation process itself and the documentation required at each stage. In order to ensure the conservation of global heritage

there are several national and international organisations that have produced guidelines setting out reliable processes that use an agreed ethical approach.

The requirements of national legislation such as the English NPPF and the German protection of cultural assets, or E.C.C.O./ ENCoRE within Europe reinforce the adoption of these internationally agreed processes.

Virtual imaging in the context of documentation can only be fully explored by first understanding the conservation process itself. However, creating a virtual image can be seen as a form of protecting cultural heritage, because the image created allows the objects to be presented virtually for the public. A few examples of scenarios where cultural heritage are in danger of being destroyed are warzones or when areas are affected by natural catastrophes such as earthquakes. Sometimes, the visitors themselves unwittingly present a risk to the buildings or monuments by transporting a damaging amount of moisture into the environment or simply by touching the walls, which can cause erosion. But also collecting virtual data from buildings means that it might one day be possible to physically reconstruct parts of the building or object and therefore present it to future generations as a physical object.

1.2. The topic of the research

The topic of this research is virtual imaging in building conservation and its application. An image was and still is an effective description of a building. Most images, such as drawings, photographs or even paintings present a snapshot of a moment from a certain time in a buildings history and presents this as visual information. Building conservation has been benefitting from the opportunities presented by virtually produced images for more then two decades. Computer based images have the capacity to transport vast amounts

of information, which are data based, and come from a range of diverse documentary sources.

Where images are considered useful for the process, they have the capacity to make a considerable impact on the contribution made by all the professionals in the conservation team including the conservator and their work.

1.2.1. Research Problem

The vast IT industry, which identified the opportunity for digital tools in the field of cultural heritage has led to the production of virtual images of all kinds. Data, which can be captured by IT-based technologies, can be used to generate virtual images of cultural heritage although they may mislead the observer.

Understanding the role of the professional use of virtual imaging is difficult, due to the various different professions within the field of conservation. The purpose or reason why a virtual image is needed and how it is used by each professional differs depending on the profession itself.

The idea of questioning the role of virtual imaging in building conservation led to the discovery of a large number of associated issues, from an acknowledgement of the sheer number of different technologies available for use, through to a consideration of how this captured data is eventually stored, to name but a few.

In order for this research to be both useful and concise, a decision had to be made as to which specific issue within the area of virtual imaging and building conservation this research should cover. To narrow this wide field down the research now focuses on documentation purpose within the field of conservation, because understanding the significance, value and authenticity of an object is based on the associated knowledge about it. A well-documented

building tells a story, which can be usefully accompanied by an image.

1.3. Research Question

Where and when is virtual imaging in building conservation supportive for the conservation work? Is it a useful method towards the protection of cultural heritage and can it be helpful for the actual conservation work? Is the documentation of cultural heritage within IT based technologies adding value?

The research question will be explored by analysing the literature, which is available regarding this specific area in the form of guidelines, charters and scholarly literature. With the aid of literature specifically concerning the case studies, which have been chosen to analyse the process and the usage of imaging as a supportive tool in the process of conservation work. Therefore, the case studies (Chapter 4, p. 158) are explored according to the usage of virtual imaging in the process.

1.4. Research Aim(s) and Objectives

The overall aim of this research is to explore the role for virtual imaging in building conservation, particularly in terms of the recording and documenting of cultural heritage required by the building conservator. This aim will be achieved through the following objectives:

To understand the conservation work the presentation of both national and international conservation processes will be analysed. Key concepts will be identified and discussed in order to understand the conservation work and its process. The role of imaging within this process will also be discussed and within this the precise role of the conservator can be identified.

The conservation process is structured into specific stages, which will be clearly outlined and within these stages an analysis of where and when documentation is required will take place.

From here the purpose of imaging in conservation will be established. Within this analysis, the technology, which is required to produce virtual images, will also be identified and explored. Issues, which arise through its usage, particularly the appropriateness and ease of interpretation when creating a reconstruction of cultural heritage in the field of building conservation, will also be discussed.

A critical assessment of examples, which utilise virtual imaging as a documentation tool will also be discussed and it is here that the relationship between imaging and the conservation process, will be established.

Two case studies will be investigated in more depth. These case studies have been chosen due to their structured conservation processes, where imaging can be clearly investigated through the different stages of the conservation process.

The advantages and disadvantages of virtual imaging and identifying whether or not the virtual imaging is benefitting the conservation projects is explored and discussed in examples outlined in Chapter 3 and in the two case studies described in Chapter 4.

Through these objectives the role and value of virtual image in building conservation will be established.

1.5. Hypothesis

Hypothesis: Conservation work today is strongly influenced by IT-based technologies. Can an increase in IT-based imaging support the documentation, recording, interpretation and specification in architectural conservation?

1.6. Methodology

The research methodology consists of three components that allows the analysis and comparison of published literature, applied practice and professional experience:

1. A desk-based literature review;
2. Field work, which will include identifying and critically assessing case studies of conservation projects which have used virtual imaging;
3. Interviewing identified experts, visiting workshops and attending conferences.

The research methodology framework is based on the following steps:

1. Literature Review – conservation principles and guidelines, conservation charters, conservation process, documentation, the role of a conservator in the conservation process, computer technology and imaging.
2. Case Studies – two German conservation projects, which have conserved and partially reconstructed buildings virtually. In one of the case studies the author was the conservator, therefore the author's professional experience of conservation practice is included here.

Finally, all the included chapters have been assessed from the perspective of a conservator and the professional experience of the author has allowed the analysis of the issues to be through “informed eyes”. The analysis of the data has been brought into context within conservation process. This is outlined in Table 1 (p.86) and with the aid of this table imaging and its uses have been explained. The identified regulations within a conservation process are compared between different projects and the discussed in relation to each other. This method shows groupings or variables, which help to analyse the role of virtual imaging (Sharp, J., p.111 onwards).

1.6.1. Method

The literature review studies the conservation process from a number of related perspectives. Firstly, it looks at the function of conservation principles and guidelines and the resulting nature of documentation in the conservation process. It also looks at the role of different specialists in the conservation process, in particular the conservator and how they use, access and produce various types of documentation, images and materials. The final stage outlines the use of computer technology and imaging as part of this process. Through this review, a framework was developed that mapped these different aspects of the conservation process. At each stage the conservation process is mapped against a framework that studies the work in relation to which professional was involved in the process and the role of imaging:

- Historic building actions
- Recording methods
- Action carried out by which professional specialist in the conservation

process (e.g. Conservator, Building Surveyor, Architect, Architecture/Art Historian, Archaeologists, Monument officer)

- Use of Imaging
- The case study methodology has been used to study how two conservation projects used virtual imaging as part of the conservation process. Two building projects were selected to be studied to analyse the usage of imaging for recording and documentation purpose within the conservation process;
- St. Kastulus Münster, Moosburg a.d. Isar, Germany
- Aachen Dom (Cathedral), Germany

The projects were selected because they were both historic monuments undergoing a conservation process that were using virtual imaging in a range of ways as part of the conservation management plan. For the research question the conservation management plan has testified and analysed.

The first case study Moosburg, St. Kastulus Cathedral (Figure 1, p.12) is a church with one of few remaining roman portals in this region. This portal has been researched by archaeologists' and conserved by conservators. The project was started around 2008 and was finally finished in the year 2012.

Due to the work that was carried out the portal is now stable and secure. The monitoring, which was undertaken by the University of Bamberg should support the protection of the portal by repeating the monitoring in a five-year rhythm.

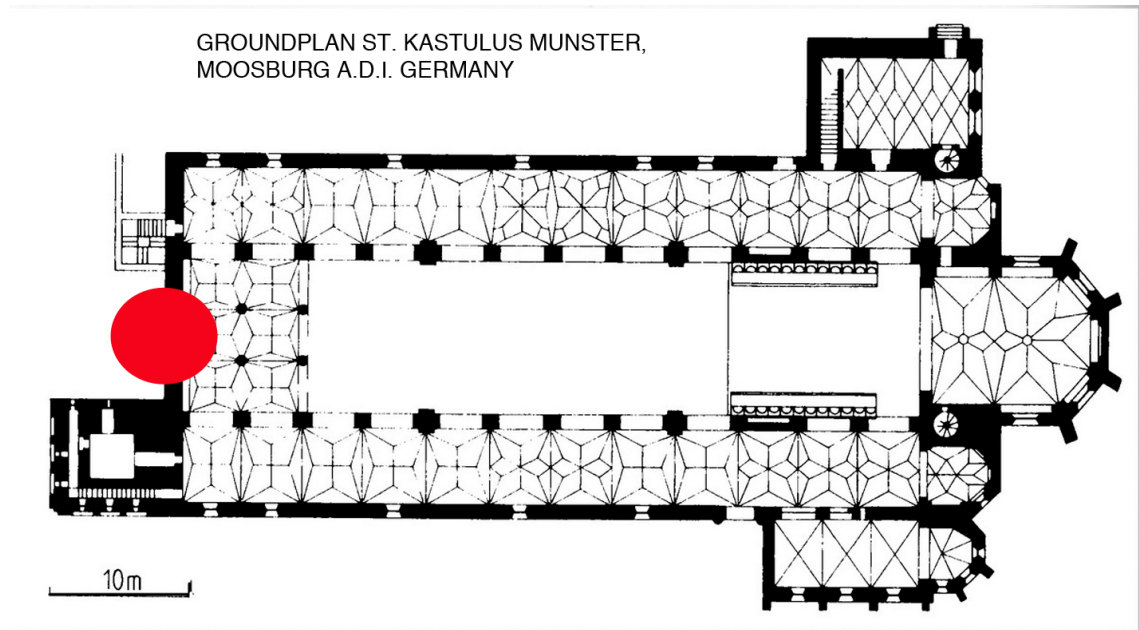

Figure 1: Ground plan St. Kastulus Cathedral

The red dot marks the location of the portal

The second case study The Aachener Cathedral is part of an ensemble. The analysis of this ensemble was focused of the Palatine Chapel and the northern basilica (Figure 2, p.13). The documentation of the analysis, the work and the outcome are published by the LVR (Rhineland conservation institute) and is good and accessible. The aim of this project was to analyse the stone used in the walling and to provide an analysis of the stability of the structure, but also to research former structures and present them within a virtual image.

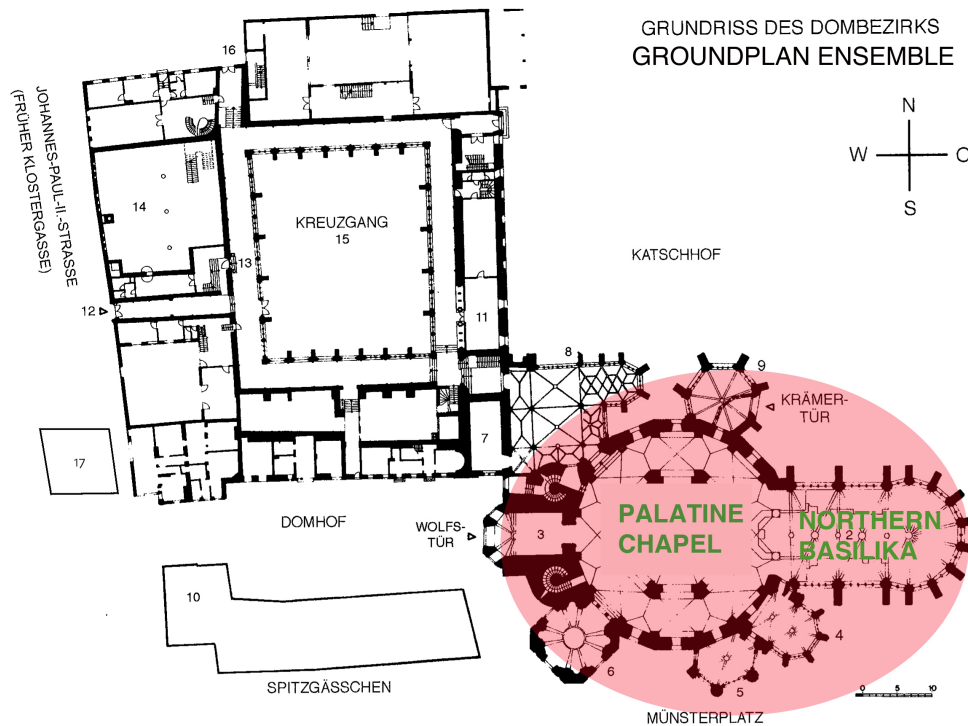

Figure 2: Ground plan of Aachener Cathedral

The reddish marked the area locates the building of interest in this research

Both the projects outlined above took place in Germany, as this is where the author is based and where she is currently employed as a conservator.

1.7. Literature Sources

The aim of this literature review concerning cultural heritage and its documentation is to clearly identify the role of imaging in building conservation. This analysis of the current literature is crucial in identifying the role of virtual imaging in building conservation and one of the key sources of information used were the International Conservation Charters, which contain the principles of the practice of conservation and identify the agreed ethical perspectives and the importance of cultural heritage, together with practical guidelines and definition of terms (Bell, 1997, p.1).

Understanding cultural heritage is based upon knowledge about the definition of key concepts and their use in the conservation process. These definitions have been discussed by committees and agreed by ICOMOS. For this research, key concepts such as authenticity, value and significance have been evaluated with reference to International and National charters, which identify and discuss these key concepts (p.15). The literature sources include the examination of good practice advice and guidance in conservation processes and management plans. This will help to identify the purpose and nature of images in the process of conservation work. This is a critical element of the research, as the aim is to focus specifically upon recording and documentation within the conservation process.

Other literature that focuses more specifically on virtual imaging and IT-based technologies within conservation work will also be discussed.

Examining the existing literature on virtual imaging in recent conservation projects will allow identification of the on-going development and application of computer-based imaging in this field and will also provide appropriate examples to illustrate the following text.

Value, likewise significance, authenticity in reconstruction¹³, conjecture¹⁴ and reproduction¹⁵ are key concepts and aspects for this research, which have been identified in charters and scholarly literature.

¹³ Definition in GLossary

¹⁴ Definition in GLossary

¹⁵ Definition in GLossary

1.7.1. Key Concepts

For this research, the key concepts of value, significance and authenticity have been identified in relation to virtual imaging in building conservation and are therefore discussed in more detail in Chapter 2 (p. 45; definitions of these key concepts can be found in the Glossary).

Nationally and internationally agreed doctrines, guidelines and documents provide an understanding of cultural heritage, and help to facilitate its conservation. The aim of this research is to discuss the purpose of virtual imaging in building conservation, particularly in relation to documentation.

Documentation consists of records, which support the understanding of buildings and their history and the need for documentation was initially identified in the 19th century, in the “Request” of the *Congress on Protection of Artwork and Monuments* during the World Exhibition in Paris, 1889, whilst the 193 “Athens Charter for Restoration of Historic Monuments” recommends the publication of an inventory of ancient monuments with photographs and explanatory notes as official constitutional records.

Whilst article 1 of the Venice Charter, 1964, recognises the importance of a building`s history, both the Venice Charter and Faro Convention (2005), highlight the significance of monuments for human beings. National and international awareness of heritage includes the recognition of the importance of recording aspects of our heritage in order to both understand and value it. For instance, in the *Principles for the Recording of Monuments, Groups of Buildings and Sites*, Sofia (ICOMOS, 1996) the definition of a record is:

“Records of monuments, groups of buildings and sites may include tangible as well as intangible evidence, and constitute a part of the documentation that can contribute to an understanding of the heritage and its related values” (ICOMOS, 1996)

Knowledge and understanding of these sources of information, in other words that documentation is essential to establish values, are at the root of all conservation. In addition, understanding documentation, which outlines the value allows an assessment of authenticity. EH/HE identify a list of value in “*Conservation Principles, Policies and Guidance*” (English Heritage 2008, p.27-32). Therefore, recording documentation is important in trying to understand historic assets as a whole. Only by knowing the past of an object can the value and significance of it be addressed and acknowledged today. However, as mentioned in Nara Document (1994) under point 9, it is also important to know the source of information and whether this source is truthful. Although Jokilehto writes that the principles in conservation should be understood as the highlight of the theoretical work in cultural heritage, the international agreements should be questioned and due to changes in the world they should be testified as proof of validity (Jokilehto in Richmond and Bracker, 2009, p.73).

The Nara Document, 1994, revised as Nara +20 in 2014, focused upon authenticity and is a very important document for this research. Understood as a key concept in cultural heritage, authenticity is influenced by cultural understanding, which varies from country to country (Chapter 2, p. 46/47).

Value is always dependent on beliefs and individual measures. That is why the World Heritage Committee has listed several points to clarify the value of cultural and natural heritage. Although the focus of this research is not upon the heritage of Outstanding Universal Value with international significance, it has

relevance for heritage of national, regional and even local importance

(Operational Guidelines for the Implementation of the World Heritage

Convention (2016), in Article 49).

“Conservation of cultural heritage in all its forms and historical periods is rooted in the values attributed to the heritage. Our ability to understand these values depends, in part, on the degree to which information sources about these values may be understood as credible or truthful.

Knowledge and understanding of these sources of information, in relation to original and subsequent characteristics of the cultural heritage, and their meaning, is a requisite basis for assessing all aspects of authenticity.” (Nara Document, 1994, par. 9).

It acknowledges that the process does evolve and therefore the validity of conservation principles may be questioned.

Understanding the key concept of authenticity in the context of cultural heritage means to understand the significance of tangible and intangible heritage and in turn this leads to an understanding of the intrinsic value of this heritage.

In other words, when putting the keywords authentic, value and significance together the basis of the physical conservation work has been set.

1.7.2. Reconstruction, Conjecture, Reproduction ¹⁶

In the context of this research, reconstruction, conjecture and reproduction are important aspects to discuss especially in the evaluation of virtual imaging as a tool of reproduction and documentation. The creation of a virtual image is based on knowledge from the original building, therefore the modelling with the aid of IT technologies is a reconstruction of the original physical building. Due to the lack of knowledge most of the reconstructions involve conjecture.

¹⁶ Definition in Glossary

The reconstruction of cultural heritage is acceptable if the damage has been caused by disasters such as war according to the Declaration of Dresden (1982). However, this reconstruction can only take place if there is accrued prior knowledge based on previous documentation.

Reconstruction is defined in the New Zealand Charter (2010) as:

“Means to build again as closely as possible to a documented earlier form, using new materials.”

The understanding that conservation guidelines and charters identify authenticity in conjunction with integrity as fundamental principles for cultural heritage conservation, leads to the question of how much conjectural work is required for visualisation in conservation? This issue will be discussed in more detail in Chapter 3 using specific examples of the visualisation of heritage.

Comprehensive documentation is required to reconstruct a building fully or partially and avoid conjecture, although partial documentation and conjecture may be considered as appropriate in reconstruction in some circumstances, for example, Frauenkirche in Dresden, Germany or Mostar Bridge in Mostar, Herzegovina. Taking the step from reconstruction to conjecture work is to tread a fine line, as conjecture work in the context of cultural heritage is deceptive. As it has been described in Historic Scotland’s *Technical Advice Note TAN 8* (Bell, 1997, p.29, 30), the danger with conjecture work is that the authenticity of cultural heritage may be lost.

In considering the charters, guidelines and principles, which should be understood as the backbone of conservation work, other keywords such as reproduction should be discussed in relation to the role of virtual imaging in building conservation.

The issues concerning reproduction, copies and reconstruction have many transposable cross-sector similarities. The introduction of new techniques, especially in a profession such as conservation, which believes in tradition, requires a discussion around the 'role of reproduction', which today will clearly involve some type of virtual imaging.

A very early example of the use of reproduction was in the *Paris Congress* (1889) where the reproduction of works of art was suggested as a learning tool in order to better understand the former styles and epochs (Article X. from Monumenta I, p.19).

When looking at reproduction in relation to cultural heritage, virtual imaging can also help to explain the history of buildings. Producing a reproduction of a building from a certain period in history using virtual modelling may mean that a better understanding of that building is acquired. And by using the knowledge from former studies of the buildings, including documentation on techniques and styles, it is also possible to fairly accurately reproduce an entire building.

1.7.3. IT based Conservation Charters

Traditional conservation work is based on physical objects and buildings, however, in the context of this research, which focuses upon the role of virtual imaging in building conservation, in relation to documentation, the definition of reconstruction, as described in the subheading above (p.17), has to be mentioned in the context of a digital/ virtual¹⁷ nomenclature.

The definition of virtual imaging (see Chapter 1, p.4) within the context of cultural heritage is included in charters, which specifically address computer-

¹⁷ Definitions in the glossary

based technologies such as the *London Charter* (2009/2013) and the *Principles of Seville* (2011).

The *London Charter* (2009/2013) is divided into six principles, which stress the implementation, aims and methods, research sources, documentation, sustainability and access.

The charter points out, that computer-based imaging in the context of cultural heritage should help to further understand the object, but also support communication about possible intervention. It is certainly a method, which should be used wisely, due to the costing. However, with reference to the aforementioned key concepts within the field of conservation, authenticity for example, is not mentioned specifically in the *London Charter*. Although, principle 3 “*Research Sources*” points out in article 3.2 that the sources should be chosen, analysed and evaluated according to current understanding and best practice models within the various professions associated with the field of cultural heritage.

The *London Charter* (2009/2013) supports computer-based methods for Cultural Heritage, however it carefully points out that the work should also consider the other Charters, which are relevant for the asset type. It also stresses the importance of the traceability of outcomes. In other words, the documentary sources used to achieve virtual images need to be recognised in order that they can be referred to for establishing the accuracy of the image.

The *London Charter* (2009/2013) relies on the code of ethics¹⁸ in conservation set by other charters, which is certainly very important within the field of cultural

¹⁸ Definition in Glossary

heritage. In the field of conservation work the use of virtual imaging can fulfil the role of education. However, the charters do not have the jurisdiction to ban other professions from using cultural heritage for other purposes such as entertainment, although it is archaeologists who use this, it is also applicable to other professions working within the field of cultural heritage.

The Principles of Seville have adopted the objectives of the London Charter and extended them with 8 objectives:

1. Interdisciplinary, 2. Purpose, 3. Complementary, 4. Authenticity, 5. Historical rigour, 6. Efficiency, 7. Scientific Transparency and 8. Training and Evaluation.

(Principles of Seville, 2011 objectives).

The Principles of Seville stress that the use of IT based technologies involves a professionally trained team from different disciplines such as computer experts, archaeologists, architects, engineers, managers or other specialists in the field. A good exchange of information is required to enable the team has to work together and it is vital that the aim or purpose of the project is clearly established at the start together with a management plan. The computer-based technologies, which are used to add knowledge and to improve images, should be transparent, and any hypothetical additions clearly marked.

Working with computer-based technologies still implements a solid research base and good documentation of the object and the work. The Principles of Seville also point out that the efficiency of each tool should also be checked and the best tool should be selected to support the aims of the project, but the costing should also be clearly controlled. The most expensive option is not always the best way to achieve the goal.

The outcome evaluation of a visual documentation can only be measured by the content not by its spectacular results. The aim of the use of virtual imaging in the field of cultural heritage should be to present evolution, working steps and or adding knowledge (Principles of Seville, 2011, p. 5-9).

1.7.4. Conservation Process

An understanding of the structure of workflow within the field of conservation is necessary to evaluate the role of virtual imaging. Different institutions have different agreed structures and fundamental courses of action for the work involved in conservation. Historic Scotland has presented a conservation activity plan in the *Technical Advice Notes TAN 8* and English Heritage developed the 'Conservation-based Research and Analysis (CoBRA)' article which was published in 2001 in *Informed Conservation* a monograph by Kate Clark. Both plans refer to defined steps, which allow the production of a conservation action plan or, which describe future actions (Bell, 1997, p.34; Clark, 2001, p.62). The conservation plan should be structured, as described in *Conservation Plans: A Guide to the Preparation of Conservation Plans* as: an introduction, a summary, a description of the site, an assessment of significance, an assessment and analysis of conservation needs, an action plan, and finally a review of arrangements and supplementary information (Historic Scotland, 2000, p. 5-9). On page 15 and 16 of *Conservation Plans: A Guide to the Preparation of Conservation Plans* is a summary of the content of each heading mentioned above. The assessment of significance is a very early task and should include a site survey, and a recorded history (Historic Scotland, 2000, p.5, 6). In *Conservation Plan* (2013, p.4) Kerr explains that a clear understanding of the level of significance supports the management of a place, which includes

informed policy decisions. Kerr also implies that a clear understanding of significance supports the future actions and may allow adaption or development for the cultural heritage.

Following the completion of a conservation plan, a conservation management plan or action plan also has to be put together. The management plans organise the workflow within the conservation project (Clark, 2001, p.66). The management plan requires different specific steps to be followed, and the creation of a structured and well-thought out plan allows successful outcomes to be achieved. It also clarifies at what stage documentation, including imaging, is supportive for the conservation process. Chapter 2 discusses conservation management plans in more detail.

1.7.5. Documentation¹⁹ and Recording²⁰

Understanding Historic Buildings – A Guide to Good Recording Practice, revised by R. Lane for English Heritage (2016), gives a very good overview of recording. Following a description of a record, the guide explains the method and purpose of recording historic buildings. It stresses that before any new record should be carried out the existing documentation should be identified and examined (Lane, 2016, p.3).

Different types of recording methods are described, with a summary of how each method is used as a supportive tool when recording a building. The different levels of recording are comprehensively described together with their

¹⁹ Definition in Glossary

²⁰ Definition in Glossary

outcomes to determine their appropriateness for the purpose of the conservation project. The use of digital documentation is included in the description of the levels of recording (Lane, 2016, p.25-28). This guideline will be discussed in Chapter 2 in more detail.

When the building information has been collected through a process of recording and documenting, the knowledge and understanding about the building is expanded and from there onwards a useful approach can be developed for the conservation process.

Recording assets is becoming an essential part in the management of historic buildings. Within this process, it is important to understand the former records of the building as well as producing new and up to date ones. A good record will improve the understanding of a building and assist in deciding on the methods used to conserve it.

The Getty Conservation Institute has published two publications on recording: *Recording, Documentation, and Information Management for Conservation of Heritage Places, Guiding Principles* (2007) and, *Recording, Documentation, and Information Management for Conservation of Heritage Places, Illustrated Examples* (2007). These publications outline why recording is necessary, who is responsible for creating the documentation and what its purpose is. Emphasis is placed on ensuring that the documentation is available for future generations, so interventions can be understood.

The *London Charter* (2009/2013) stresses in its principles that the purpose and the programming of IT based technologies needs to be carefully considered. Keeping that in mind, a virtual image can, in some circumstances, be a well-founded and valuable form of documentation. What should always be kept in

mind is that virtual imaging, 3-D reconstruction or even augmented reality, cannot replace the original but could broaden the knowledge of that particular building.

The Principles for Recording of Monuments, Groups of Buildings and Sites (ICOMOS, 1996), put together in Sofia, defines aspects of recording as:

- Reasons for a record
- Responsibility for recording
- Planning for recording
- Content of records
- Management, dissemination and sharing of records

This research clarifies in short paragraphs why a record is needed, it outlines the content of a record and explains how important it is to make a record public. (ICOMOS, 1996, p.49). Conservation work is greatly assisted by documentation from former times, particularly in order to understand how the building has changed. In addition, knowledge of earlier phases can inform the condition surveys necessary for proposed projects. Understanding a building is, as described earlier, a very important aspect of conservation (Lane, 2016, p.1).

However, records and the methods of documentation used must be made in a structured way, which is comprehensive and understandable not just for today's generation but also for future generations. (Wood, 1996, p.1).

ICOMOS published a *Guide for Recording Historic Buildings* (ICOMOS, 1990) in which Bill Blake outlines the purpose of providing a record of an asset, in order to inform (ICOMOS, 1990, p.3). It is also the very first step in conservation work for managing change. Without being informed about what aspect of and why a building or a part of a building is important for our cultural heritage the

conservation work has no meaningful purpose for today or the future (ICOMOS, 1990, p.3).

In the book entitled "*Concerning buildings studies in honour of Sir Bernard Feilden*" (Marks and Feilden, 1996) the chapter *Assessment and Recording - A practitioner's View* (1996) by J. Cox is critical of certain ways of undertaking assessment and recording and stresses that the very first assessment of a building should be non-interventional. (Cox, 1996, p.125, 126). Cox underlines that a good written report should interest the reader, as well as the building owner and the professionals involved in the project. A short, written report including all the important information, drawings and images, might contribute more value to the project in comparison to a long-written report due to a deeper level of understanding (Cox, 1996, p.153, 154).

She also pleads for an assessment and a report that is both planned and delivered on time. The satisfactory outcome of this work is crucial for the whole conservation process (Cox, 1996, p.156).

An important reference in the discussion regarding recording through the use of images is the guide produced by Historic England (2016) *Drawing for Understanding*.

A drawing can be a powerful analytical tool, which can help to interpret various aspects of the building (Adams, 2016, p.1), it can support the process of record making, due to the different methods and types of drawings involved. For example, there are traditional hand measured drawings, total station surveys, photogrammetry, rectified photography, and 3D laser scanning (Adams, 2016).

This guide complements what is described by Cox (1996) about the importance of drawing under the subheading Drawing and Photograph (Marks and Feilden, 1996, p.131).

The publication *3D Recording, Documentation and Management of Cultural Heritage*, (Stylianidis and Remondino, 2016) discusses computer-based tools used within the field of cultural heritage. It analyses current trends in cultural heritage, conservation techniques, management tools, techniques for imaging, 3-D modelling and 3-D recording and documentation. Chapter 1 “*Current trends in Cultural Heritage and Documentation*” is an important chapter for this research as it points out the importance of knowing and understanding the relevant tools (see 1.7.6.1 Devices) particularly with reference to what they are able to produce. It also mentions that the information collected and recorded must be proved in order to be both accurate and reliable. Understanding the tools is certainly important but knowing what the tools can deliver in terms of results and as a method of recording needs to be assessed (Stylianidis and Remondino, 2016, p.12). The book describes the different techniques that are available and what they can achieve. It is a good overview and is useful for professionals involved in and dealing with the recording of cultural heritage. Looking critically at the different tools and methods of recording helps us to understand the possibilities of virtual recording methods. However, because there is very little research on methods of recording specifically in terms of conservation most of the authors mentioned in this chapter were trained in archaeology, civil engineering or similar.

1.7.5.1 Time

The study of historic buildings within IT based data sets is a helpful instrument for understanding cultural heritage (see 1.7.5. Documentation and Recording).

The representation of the past through virtual imaging may be understood as a difficult task. As pointed out in the London Charter (2009/2013) and the Principles of Seville (2011) it needs to be absolutely clear what is going to be presented with the IT based technologies. In the book, "*The virtual representation of the past*" (Greengrass and Hughs, 2008) the form that the presentation of virtual images takes is discussed.

Mark Greengrass (2008) describes the reconstruction approaches taken by historian and archaeologist researchers working in the field of cultural heritage. The knowledge that researchers within these two disciplines gather from the buildings past and its surrounding landscape informs the conservator about the significance and authenticity of a historic building. However, building conservation deals with the existing fabric of a building, how to preserve or conserve it and maintain the authenticity of a significant building whilst still being able to use it (functionally) for today's purpose. However, the professionals from all the three disciplines described above concern themselves with providing a representation of the past.

"This volume is dealing with the question of the methodologies, tools and the applications of advanced computing to assist us to make sense of the incomplete, contradictory or doctored evidence of the past" (Greengrass and Hughs, 2008, p.2).

It is important to note however, that not just any visualisation can provide the knowledge required to make important decisions affecting aspects of significant cultural heritage. The quality and depth of a visualisation in the context of

accuracy (discussed 1.7.6.1 Devices) and the time (see 3.3.2. Phase study of a historic building using IT-based imaging) of the information source also needs to be considered.

The virtual presentation of an object needs to be precisely put into the context of its history and unknown areas should be presented as indefinite. Thaller in "*Part III The Virtual Representation of Space and Time in the chapter: Which? What? When? On the Virutal Representation of Space and Time*" points out that these unknown aspects may be presented in the form of a distinct data (Thaller 2008, p.115). This data set could be semantic technologies and BIM (see 3.1.2.1. GIS and BIM).

Thaller (Thaller, 2008, p.115-124) classified three different starting points for the virtual representation of time:

- Research politics²¹
- Technology
- Cultural heritage information systems²²

"Technology" is in the context of this research crucial. (Thaller 2008, p.116-121) Thaller closely examines the aspect of "time", which he divides in 4 points:

- The philosophical question of what time is
- The computer science question as to how a specific view of time can be represented and processed
- The pragmatic question of notation of time within a working environment

²¹ The work of professional researchers is strongly influenced by funding, disciplines, hierarchy and competition. Martin, B.,1998, *Information Liberation*, London: Freedom Press

²² Digital resources in the cultural heritage world, Greengrass, 2008, p.121

- The question of how time should be integrated into the overall design of an information system.

The word “time” and its meaning in different working fields need to be defined, before creating a sufficient information system. Thaller (Thaller 2008, p.116) points out that this can be done, but that it still requires some problem solving in terms of computer processing.

The discussion about time is crucial for its representation of cultural heritage. It is intensively discussed in relation to the use of “Geographic Information Systems “(GIS), which is a common tool in archaeology for identifying the landscape and manipulating data resources. In building conservation, time may be more likely to be seen in the sense of periods or even centuries. An understanding of the term “time” depends on the professional field in which it is being used. But how can this crucial issue be displayed in a virtual image? Is a written comment enough to avoid misunderstandings? But its not only the issue of time but also the ‘what’ and ‘where’ also needs to be questioned. Computer-based imaging simplifies research in the meaning of accessibility.

Subsequently, it can easily limit the view of a building to the creators’ eyes of what and how to display of this specific building or aspect of it. It may not be possible to transpose the information from an entire building into a virtual image (Thaller 2008, p.116-121).

1.7.6. Virtual Imaging

The focus of this research is the role of virtual imaging in the context of documentation for building conservation and a useful reference within this discussion is Felix Horn's thesis *Digital Imaging in Conservation* (2003) which although he considers the use of digital imaging in the conservation of paintings,

his conclusions could in fact be transferred to consider the conservation of buildings.

“Minimising intervention on a work of art can be considered a remarkable advantage in terms of preventive conservation....

Replacing a work of art with a copy by means of digital image processing enables an artwork to be removed from a damaging environment and rather be stored under optimal conditions” (Horn, 2003, p.57, 58).

Horn (2003) emphasises minimal intervention, a principle agreed by the international charters and recommended for building conservation (Bell, 1997, p.1). In the New Zealand Charter (2010) this could be described as preservation, which is defined as a process “To maintain a place with as little change as possible” (ICOMOS NZ, 2010).

Whilst Horn`s recommendation that works of art could be replaced by digital images, unlike paintings, entire buildings are unlikely to be removed to protective environments, however vulnerable components could be moved for their protection. In some instances, digital images could be used as replacements, if appropriate and accurate 3-dimensional copies could be made as replacements from the digital images.

Horn describes in his thesis the idea that digital imaging can be used for condition recording and monitoring e.g. of an object or artefact. He points out that the longer lifetime of digital documentation allows for improved comparison of data over a longer period of time than is achievable with traditional forms of documentation. He also stresses the importance of preserving the original (authentic) data and considers digital imaging as a primary tool for preventive conservation.

For building conservation, this type of tool could be used for example for reassembling the decorative parts of a lintel.

Whilst Horn`s thesis expresses the value of digital documentation, at the same time he emphasises, that it is not a replacement for the original object, artefact or building. He also stresses that virtual reconstruction is useful for the purpose of presenting a fragmentary object as a whole. His thesis considers paintings therefore his suggestion for such presentations are mainly useful for the sorts of things that might be displayed in museums, but it is difficult to use this type of work for building conservation.

For that reason, Horn (2003) considers virtual imaging as a decisive and supportive agent. The value of a virtual image with all the associated information, such as measurements and details of former repairs can be a very useful supportive document for the actual object, as long as the workflow of the IT based work has been precisely recorded, if this is the case then other professionals can re-use the virtual image, which is also outlined in the Principles of Seville (Principle 7).

Surely the stability of electronic documentation is unknown, as we have no long-term experience at all with regards to the future storage and access of data gathered for objects in this way. Computer generated imagery started in the 1970s, however, software programs and hardware technology change rapidly, and the question must now be asked about whether the computer industry can guarantee stable and long-term protection and access of the valuable data that has been gathered. A photograph or drawing cannot replace the original building; therefore, it is not surprising that computer-based images are unable to achieve this either.

Virtual imaging has the advantage of being easily reproduced several times, offering the possibility of setting the building in changing landscapes, adding or reducing walls, changing rooms or even rebuilding a lost part of a building meaning that presentations of past phases of the building are easily achieved through digital imaging. The use of such types of digital imaging may also help to decide whether certain areas could be reconstructed in the real world. Horn (2003) points out many of the advantages of virtual imaging, however he does not refer to the associated costs of digital image use or consider any of the ethical issues.

1.7.6.1 Devices

In this research, the focus is on virtual imaging in the context of virtual documentation. In several of the guides produced by Historic England different techniques such as photogrammetry, laser scanning, scanning, Building Information Modelling (BIM) and GIS are presented and discussed. Their guidance *3D laser scanning for Heritage*, 2011 (revised 2018), gives a good overview of the different types of scanners available and for what range and detail each one can be used. It also includes the limitations of using a scanner, which is helpful to refer to in the decision-making process of planning how to record an object. The various issues concerning software and hardware are also mentioned. This part of the guide is informative and certainly useful for the professionals involved in knowing what may be needed and the case studies in the appendices present examples what can be achieved for specific objects. The guide and some of the tables and images have been used in the research and are discussed in more detail in Chapter 3.

Another guide produced by Historic England *Photogrammetric Applications for Cultural Heritage* (2017) gives a good overview of the basic principles in photogrammetry. It outlines the process and the workflow and describes when and how photogrammetry may be supportive as a method of documentation. It also presents what kind of information this type of digital imaging transports, and what can be successfully documented with it (Bedford, 2017, p.14, 15, 19-33). The case studies (Bedford, 2017, p.80-109) presented are good examples of the usage of photogrammetry. For this research the demonstration of the photogrammetric models of three cannons from Gun Rock, Farne Islands, Northumberland (Bedford, 2017, p. 104) or the model of a coin (Bedford, 2017, p. 107) is relevant. Other examples of photogrammetry are discussed in Chapter 3, p. 100).

F. Stanco et al (2011) *Digital Imaging for Cultural Heritage Preservation* covers digital imaging in the context of preserving cultural heritage. This publication includes a paragraph about photogrammetry (p. 132 – 134), too. The data processing has been outlined and the possibility of quality is discussed. F. Stanco et al (2011) *Digital Imaging for Cultural Heritage Preservation* covers digital imaging in the context of preserving cultural heritage. This publication includes a paragraph about photogrammetry (p. 132-134) as well. The data processing has been outlined of quality is discussed. Further on the book includes information on digital images, covering the technology and also an investigation into its use in cultural heritage projects (Stanco et al., 2011, p.37-127). In Chapter 5 with the title *Accurate and Detailed Image-Based 3D Documentation of Large Sites and Complex Objects* analyses the different techniques in a well-structured way, including also discussion on the issues

surrounding the internationally agreed standards in cultural heritage. Under the heading, *Standards in Digital 3D Documentation*, the importance of finding an international agreement for these standards is discussed (Stanco et al, 2011, p. 131). These issues will be discussed in the research in more depth in Chapter 2. At the end of the book in Chapter 17 the issue of copyright is covered, which is a very important issue with regards to virtual and digital technologies (Stanco et al., 2011, p.451). The copyright of images especially in the context of cultural heritage, and museum objects, is crucial. Watermarking the images is a way of protecting the work. The question about these rights needs to be solved in advance. Due to the complexity of the copyright issue and the focus of the research being primarily on virtual imaging in the context of documentation the problems around copyright could not be covered in any more detail, however, it is a very important issue and should be analysed in the context of cultural heritage.

1.7.6.2. Responsibility

The advanced technical knowledge, which is needed for producing virtual imaging, widens the field of professionals involved in conservation. The conservator/ restorer is therefore dependant on other professions in the field to achieve a good record and document. As discussed in 1.7.3. the usage of computer-based technologies is an interdisciplinary (Principle 1 of Principles of Seville) field. Gathering the knowledge of a building and bringing the information together in one document necessarily involves several professions and the author has attended several conferences, which outlined the multiple use of the knowledge from other disciplines. At the Electronic Media and Visual Arts (EVA) Conference in Berlin in 2012 concepts, strategies and standards of art

historians towards the technique of digital modelling were presented and are very valuable and applicable to use in building conservation. Prof. Dr. Stefan Hoppe and Dr. Georg Schelppert, presented a paper on *Historical objects and digital modelling: Current concepts, strategies, standards*. In it they describe data modelling as a tool for converting the knowledge accrued about an artefact or building into the shape of an image (Hoppe, 2012). Prof. Großmann (who is Director of the Germanisches National Museum in Nurnberg, Germany) describes it as 'creating a world in digital models. Hoppe and Schelppert (2012) refer to art history, which uses images to describe and illustrate findings. They stress the advantages and flexibility of digital models, meaning the physical building is not touched and the virtual image can be used to clarify earlier phases of the building over time and to discover which parts of the building have been rebuilt. This text clarifies that the usage of virtual models in art history helps to understand artefacts and buildings by illustrating the changes of an object over time. The authors point out that it is a tool for combining findings. However, they also make clear that during the process decisions should always be based on how accurately detail can be represented using this method (Hoppe, 2012, p.14).

How different professionals involved in the process of documentation use these tools is described in more detail in Chapter 2.

The role of a conservator in a conservation project can be very different depending on the tasks required for the particular project. From the authors experience a conservator can undertake a damage survey of the object, creating with this knowledge a concept for the work in order to allow the project to go ahead. Another task the conservator can be involved in is the supervision

of the actual work, doing quality checks and controlling what happens, when and where. Or the conservator can be directly involved with the hands-on work within the project, to include the documentation. The work of a conservator depends primarily on the qualification of the conservator has undertaken, which is described in *Europeans Confederation of Conservator-Restorers Organisation* (E.C.C.O., 2011) in the publication *COMPETENCES FOR ACCESS TO THE CONSERVATION- RESTORATION PROFESSION* (2011) on page 20/ 21 a diagram in detail. In this publication, the mission of E.C.C.O for the profession of conservation and restauration is described in this publication from 2011 but also on their homepage as:

“To organize, develop and promote, on a practical, scientific and cultural level, the profession of the Conservator-Restorer.” (E.C.C.O., 2016/ 2017)

The safeguarding of cultural heritage is complex, due to the different professions involved in the process, from understanding historic buildings and places by research and observation, defining cultural heritage as a valuable and significant asset, through to the actual preservation/conservation work itself. To successfully achieve the documentation required at each stage of the conservation process numerous digital tools are now available including virtual Imaging.

Digital imaging²³ or even 3D reconstruction²⁴ allows aspects of our cultural heritage to be presented virtually, which could be considered as a form of protection and preservation. This can be useful in the management of large

²³ Definition in Glossary

²⁴ Definition in Glossary

numbers of tourists by keeping them open to the public at least virtually. A virtual reconstruction includes a lot of complex information about the object, a lot more than simple visual imagery.

1.8. Analysis and discussion

Reviewing the different charters has helped to present a general understanding of cultural heritage together with a brief overview of the key concepts used in conservation, which will be discussed in more detail in Chapter 2. The importance of the documentation of a building and its relationship to these key concepts has developed over time as is evidenced in the international agreed charters and principles (see also, p.13). Charters, e.g. the London Charter, which deal specifically with computer-based technologies are supporting innovation in the field of cultural heritage. They point out the need to explain how the required images can be created and for what purpose they can be used. This has been useful with reference to the research question concerning virtual imaging as a form of documentation in building conservation. Understanding the definition of keywords relating to cultural heritage is vital and this leads to the next discussion within the research, which is conservation management. These issues will be looked at more closely in Chapter 2, which also discusses the conservation strategy.

In this chapter, much of the relevant literature, which has been considered and discussed, was produced as technical advice guidelines for conservation industry professionals by Historic England and Historic Scotland. These guidelines are regularly revised in order to stay up to date with developments such as advances in virtual imaging. They represent one of the main sources, by which to inform professionals about changes in legislation and practice in

addition to technological developments. The structure of conservation processes and conservation management plans are nationally recognised. The difference between the management plans from Great Britain and Germany are greater than the author originally assumed they might be. Britain has very structured conservation processes, whilst Germany in comparison keeps conservation work guidelines more general without establishing specific planning strategies. These differences are discussed and compared in more detail in Chapter 2.

The advantage of having very specific outlines for conservation management plans, is that it helps maintain clarity for the different professions that are involved in the project at different stages. With very clear plans they are able to adopt and identify their own role and work specifically within the appropriate stage of the conservation process. In Germany, the different stages of a conservation process are not specifically identified with a specific profession. It can vary from project to project and is dependent on individual decisions and who is involved in each project.

The methods and purpose of virtual imaging use have been discussed in this chapter with particular reference to the article of Thaller (2008). A more critical view of the tools used in virtual imaging will be presented and discussed in Chapter 3. What has been established here is that an understanding of the range of outcomes achievable through the use of various technologies and being able to decide what technique might be useful needs to be assessed in the first part of the conservation process and is often specific to the requirements of object or building itself.

Cultural heritage projects involve many different professionals such as architects, archaeologist, conservators, art historians, to name a few, due to the range of interest in historic monuments and artefacts. The challenge of protecting cultural heritage is huge, due to its interdisciplinary nature, but also because of the complexity of the term heritage. The work of a conservator relates in particular ways to the work of the other professionals involved in a project and this will be discussed in more detail in Chapter 2 (p.75).

1.9. Summary

Chapter 1 outlines the research topic including the problems that occurred during the research. It discusses key concepts relating to conservation work and in particular those referring to documentation. Historic Building documentation comprises of a collection of records, which inform cultural heritage. The importance of historical sites or assets and how to deal with them in a professional way has been summarised by a range of charters, guidelines and principles. Within the charters the importance of documentation in the field of cultural heritage has been highlighted. Therefore, the benefit of images for recording purposes is explored in the following chapters to include a critical evaluation of the use of modern technologies for reproducing and recording cultural heritage, providing clear and systematic guidance as to how that heritage should be conserved. This introduction provides a general understanding within the field of cultural heritage.

CHAPTER 2 – Conservation Strategy

This chapter discusses the conservation workflow by analysing the key concepts and conservation management plans. The focus in this chapter is on where imaging is being used within the conservation process and how and why images can support this work.

2. Introduction – Conservation Process and the Role of the Conservator

Today, conservation work is frequently structured by conservation management plans, which adopt the agreed conservation process to achieve a satisfactory final outcome. J.S. Kerr was a pioneer in conservation planning. Within the Burra Charter (1979) he set out a concept to identify the values at the core of the conservation process (Drury, P. 2012). From this work the conservation management plan has been more and more developed and adopted by many different professionals. Kate Clark pushed the idea forward and developed a layout for the conservation process starting in the late 1990s. English Heritage's *Conservation Principles, Policies and Guidance* (2008), has been developed by public policies and conservation practice (Drury, P., 2012) and defines conservation as:

“The process of managing change to a significant place in its setting in ways that will best sustain its heritage values, while recognising opportunities to reveal or reinforce those values for present and future generations.” (Drury, 2008, p. 72).

This definition is forward looking and emphasises change, placing the values of understanding at the core of the conservation process. Clark confirms this focus upon significance:

“What distinguishes that which might be conserved from that which will not is value or significance.” (Clark, 2001, p.12)

Kerr influenced Clark`s guidelines *Informed Conservation* published by English Heritage in 2001. She also points out in Section 6 of this guide the importance of the conservation plan emphasis and the importance of significance in Section 1. The protection of cultural heritage is recognised as a comprehensive process requiring the understanding of a wide range of values to enable the design of an appropriate conservation strategy. However, this strategy must be flexible enough to accomodate unforeseen circumstances such as new information being discovered during the project or changing public attitudes (Drury, 2008).

This chapter considers two major issues: the conservation process and the relationship between the conservator and the conservation process.

More specifically, the following issues are discussed:

Conservation Ethics and Principles. This section analyses the basis of conservation work. Protecting cultural heritage is based on agreed national and international guidelines, as discussed in Chapter 1 (p.13). Within these guidelines, understanding the main principles and key concepts are essential for an overall understanding of cultural heritage.

Recording and Documentation. Under the second sub heading a general understanding of the recording and documentation of historic buildings is presented and discussed.

Conservation Process. In this third section, the conservation process is analysed, to include a discussion concerning where and when appropriate records support the process of conservation.

The second issue in this chapter considers the work of the conservator in the context of cultural heritage. Using the knowledge gained from analysing the different stages of a conservation management plan, the work of the conservator will then be discussed. The documentation and recording relating to the work of a conservator, especially in form of imaging will be considered at each stage of the process. This will be outlined in the form of a table.

2.1. Conservation Ethics and Principles:

2.1.1. Cultural Significance and Value

Cultural significance, introduced in Chapter 1 (p.1 and p. 15) describes the inherent values of an asset (NARA +20, 2014, p.3). Its importance is recognised by many sources as both the means of determining whether the asset should be recognised as part of the cultural heritage and determining the care and future uses of the asset. Charters such as the Charter of Venice (1964), the Burra Charter (2013), and the Nara Document / NARA +20 (1994/ 2014), stress the value, respect,

significance and authenticity of buildings and objects for understanding the wealth of our heritage.

Before an object can be deemed as cultural heritage, consideration should be given to whether it is significant. Cultural significance cannot be understood without recognising the values of heritage assets. European Confederation of Conservator Restorers Organisation (E.C.C.O.) lists these values in the definition of cultural heritage in the preamble of the E.C.C.O. (2002, p.1) document as:

“The objects, buildings and environments to which society attributes particular aesthetic, artistic, documentary, environmental, historic, scientific, social, or spiritual values are commonly designated “Cultural Heritage” and constitute a material and cultural patrimony to be passed on to coming generations.” (E.C.C.O, 2002, p.1)

Not only have E.C.C.O. listed the values which give a heritage asset its significance, they also highlight that cultural heritage needs to be looked at by professionally trained conservators in order to assure the best possible protection of the object. (E.C.C.O., 2011).

English Heritage`s *Conservation Principles, Policies and Guidance* (2008) also mention how important it is to understand the significance of places. One crucial point that is discussed in Chapter 3 (point 3.2) is the importance of people`s association with places. As long as forms of identification exist towards a place, the value and therefore the significance grows. It also mentions that in order to understand the significance of an object or a place it is important to first understand the place and its fabric. The conclusion of this chapter underlines the importance of not only understanding but also communicating the values and significance of

places to ensure informed decision can be made about its future. This may include statutory designation for protection (Drury, 2008, p.21).

Historic Scotland goes even further and stresses that the cultural significance of listed buildings makes 'a contribution to our quality of life' by helping us understand our past and improving the environment visually. In the *Guide for Practitioners Volume 6*, it clearly points out that historic buildings are interesting because they 'reflect the lives and achievements of our predecessors' (Urquart, 2007, p.15).

Historic Scotland argues that the history of its craftsmanship and built environment is a significant part of Scotland's history and therefore is a major aspect of people's identification with their roots (Urquart, 2007, p.15, 16). Historic England's (2016) *Local Heritage Listing Historic England Advice Note 7* also recognises the significance of non-designated assets.

In Germany, the Department for Inventory makes sure that all valuable assets are protected by being listed. Cultural significance is indirectly recognised in this process although there are no non-designated assets.

Evaluating the evolution of a building can assist in understanding its significance. Using a system of values allows any conservation intervention to be judged in a professional way.

Institutions such as English Heritage and Historic Scotland and also the German heritage departments, promote the value of our heritage by putting their guidelines (which can be understood as the theoretical standards) into a practical context.

This can then inform the production of conservation management plans. The latter was initially developed by J.S. Kerr and first published in 1982. This early date shows his work to be pioneering and it has since been of seminal influence. More recently J.S. Kerr confirms the importance of understanding cultural significance in his book *Conservation Plan* (Kerr, 2013, p.4). He stresses that understanding the building is the starting point of the conservation planning process. This usually involves identifying and understanding changes to the building due to its usage. Worthing and Bond suggest that the first time Kerr clearly articulated the link between cultural significance and conservation management was in the Australian ICOMOS Burra Charter (1999) (Worthing and Bond, 2017, p. 2), although this was achieved as a consequence of Kerr's earlier pioneering work first published in 1982.

Conservation management plans also designed to sustain the value of cultural heritage (Drury, 2008, p.22), and repeated in Historic England's document, *Managing Significance in Decision-Taking in the Historic Environment Good Practice Advice in Planning* (2015, p.2).

Technical Advice Note TAN 8: The Historic Scotland Guide to International Conservation Charters, 1997 and *Informed Conservation*, 2001 by Historic Scotland and English Heritage respectfully both agreed over 15 years ago that cultural significance should be placed at the core of the conservation process.

In the ICCROM document, *Conserving the Authentic* (2009) the word value is discussed in detail, with particular reference to outstanding universal value

(Cameron, 2009, p.127). Outstanding universal value is described in the Operational Guidelines from the World Heritage Convention (and was adopted by UNESCO in 1972) however, in the ICCROM document, the author Christina Cameron describes how it is difficult to find a working definition of outstanding universal value (2009, p. 128). The definition from the 2005 revised operational guidelines which Cameron (2009) describes as 'not particularly helpful' reads as:

“Outstanding Universal Value means cultural and/ or natural significance which is so exceptional as to transcend national boundaries and to be of common importance for present and future generations”
Paris, World Heritage Centre, Paris 2005, p. 46, Para. 49).

Not having a more comprehensive definition of Outstanding Universal Value makes it difficult to understand cultural significance on a global basis. For instance, it is very important that cultural heritage is understood as a unique tangible and intangible part of our culture.

The international definition of cultural heritage is relevant for one of the case studies in Chapter 4 of this research as it is a World Heritage Site. Therefore, it is recognised internationally and has universal value.

2.1.2. Authenticity, Conjecture Work, Reconstruction

The idea of authenticity is fundamental to conservation principles. Bell (1997, p.28) suggests that “Authenticity” is not an easy concept. Each part of a site’s development is authentic in its own rights, as a reflection of its time, and Feilden and Jokilehto (1993, p.16) observes that authenticity describes the buildings original material, which has aged. And the additions of all periods must be

respected.

In practice, determining authenticity is closely linked to the assessment of value – and can cause problems when, for instance, the idea of age value influences decisions about the relative value of more recent developments to the place.

In conservation *authenticity* is also an important concept for identifying values and in terms of this research for the evaluation of virtual images. Identifying whether a phase of a building is authentic and hence has value is important but much more important is how accepting the importance of authenticity informs the conservation project. This would include the accuracy of images created during the process and the design of intervention.

“Authenticity is perfectly described as an assessment, which is based on identification and analysis of relevant evidence and knowledge” (New Zealand Charter, 2010, definitions).

This quotation suggests that authenticity in cultural heritage is based on an understanding of the historic building. Documentation available from former research and surveys can be used to establish the authenticity of a building’s life often referred to as an “informed eye” that can interpret a building when documentation is unclear or not available. Ideally documentation and informed interpretation should be used in developing an understanding of a building to establish the authenticity of its phase. As described in Chapter 1 (key concepts), the source of the information gathered about the building needs to be reliable and comprehensive. In relation to virtual imaging, the result and the information this visual documentation transports are only as reliable as the source. But it is

essential that the computer-based visualisation distinguishes between reality and illusion (Principles of Seville, 2011, principle 4).

The Principles of Seville (2011) although intended to provide guidance for archaeologists, the importance of authenticity referred to is also applicable for virtual imaging in building conservation. Here what is real or genuine is also described as authentic and it is the authentic fabric which forms the focus of a conservation project (Principles of Seville, p.19). Therefore, the information a virtual image may transport has to be based on actual facts about the building. Although some occasions may arise when conjecture²⁵ becomes necessary in a virtual presentation to test a hypothesis.

On the actual building is conjecture work emphasising what might have been there before. In comparison to the image it is later not necessarily notable as a hypothesis when it has been constructed from the same material. Historic Scotland's *Technical Advice, Tan 8 (Bell, 1997)* points out that conjectural work including a total replacement without any justification or verification is not acceptable. It also suggests that it is important that an awareness of the original qualities of the work must be respected (Bell, 1997, p.29, 30). Original qualities can mean the original fabric of the building, however, in order to maintain buildings and objects for future generations, conjectural work may be considered in some circumstances, such as in areas that have been affected by the destructive forces

²⁵ Definition in Glossary

of either a natural disaster or war, as mentioned in Chapter 1. Conjecture work is acceptable if the authenticity of the building has not been compromised. The original materials should stay in place, and not being changed through the repair work, which might include conjecture work. Therefore, different materials or even different colour schemes are often used for interventions so that visitors are able to distinguish between the original building or object and the conjecture work.

In looking at cultural heritage in respect of recording, especially using IT based methods, the charters definition of a reconstruction is an important reference, because by using virtual imaging if appropriate, the building can be virtually reconstructed.²⁶

In certain, specific circumstances reconstruction is permitted as its definition is referred to in the *Burra Charter* (2013) as the following:

“Returning a place as nearly as possible to a known earlier state and is distinguished by the introduction of materials (new or old) into the fabric” (ICOMOS, 2013, p.2).

Understanding the significance of a building should determine whether total physical reconstruction or replication²⁷ is appropriate in part or as a whole, or whether virtual reconstruction presents an effective alternative.

Recent examples of the physical reconstruction of lost buildings, such as a castle from the 18th century in Potsdam, Germany, have instigated extensive discussions within the academic world, particularly as in this case a virtual reconstruction could

²⁶ Definition in Glossary

²⁷ Definition in Glossary

have sufficed. Never the less, the castle has now been physically reconstructed at least from the outside to reinstate its original appearance, however, the question about whether such work should be carried out in this manner or whether a new history should be written using modern architecture depends partly on the building`s significance.

Additional charters have expanded conservation principles in more depth as a reaction to changing needs and the development of new technologies.

For example, *The Charter of Lausanne - Charter for the Protection and Management of the Archaeological Heritage* (1990) introduces the idea that reconstructions are good for experimental research as well as for interpretation, to explore the various possibilities of how the objects might have looked in the past. It also suggests that the educational aspect of cultural heritage can be supported by reconstruction. The reconstruction should not necessarily take place on the actual site to avoid any possible disturbance of important remains. Therefore, a virtual reconstruction could very effectively support a developing understanding of a building. This is not mentioned directly in the Charter of Lausanne as it was published in 1990, several years before the introduction of virtual imaging in cultural heritage. However, they could be presented as working reconstructions showing the building`s phases and changes based upon a hypothesis of the history of the past without causing any disturbance to the real heritage. Therefore, virtual reconstructions of buildings could be more appropriate than an actual physical reconstruction. The Charter of Lausanne supports a dynamic approach to imaging as when new knowledge becomes available during the conservation process itself

the use of virtual images could successfully incorporate the new knowledge.

The statement that intervention should be distinguishable could also be documented within a virtual reconstruction (ICOMOS, 2012, Charter of Lausanne, Article 7, p.128)

The description of a reconstruction does not disrespect authenticity. According to several charters, reconstruction is under certain circumstances acceptable and does not cause the loss of authenticity (*ICOMOS NZ 2010, ICOMOS 1983, ICOMOS, 2012*).

Bernhard Feilden advises that if a reconstruction is too flawless, which means looking as new, or carried out without adequate study and documentation a historic building can become akin to a film set. Although, if a reconstruction enhances the understanding of the building and for instance shows its spatial qualities it is acceptable (Feilden, 1994, p. 253).

2.1.3. Recording and Documentation

The distinction between recording and documentation is important and, for the purpose of this research, it is clearly defined in Chapter 1 (p.22).

“Recording is the capture of information which describes the physical configuration, condition and use of monuments, groups of buildings and sites, at points in time, and it is an essential part of conservation process.”
(*ICOMOS 1996, p.49*)

This definition emphasises that the *recording* of cultural heritage is a key element within conservation work. As discussed earlier in this chapter under the sub

heading *Ethics and Principles* (p. 43) documentation provides knowledge of the historic building.

The Principles for the Recording of Monuments, Groups of Buildings and Sites (ICOMOS, 1996), outlines many of the *reasons for recording* within the field of cultural heritage to include the development of an understanding of cultural heritage, its values and evolution. These principles not only point out why recording is essential, they also describe how the recording is supportive as a method for the process of identification, understanding, interpretation and presentation of heritage. The responsibility for recording is also explained in ICOMOS (1996, p.50) and it is stated that certain skills from different professions might be necessary in order to achieve an appropriate record. Also, it makes clear that the content of a record has to be outlined and put together in a structured framework. The final principle focuses upon the management, dissemination and sharing of records (ICOMOS, 1996, p.52).

The aim of these Principles (1996) were:

"Principal reasons, responsibilities, planning measures, contents, management and sharing considerations for the recording of CH." (ICOMOS, 1996, p.49)

2.1.3.1. Discussion

Established charters, guidelines and principles aim to document cultural heritage before and after the conservation work has taken place (e.g. the Venice Charter 1964). However, in practice the structured recording of conservation work can be time consuming and therefore the conservation practitioner may rely partially or even totally on existing sources of documentation, which can lead to inaccurate information. Therefore, the documentation of a building should be done as guidelines recommend.

Early ground plans, drawings, and topographical maps are a starting point for compiling a folder of existing documentation in order to understand the origins and phasing of a building. The written word, which can be understood as an 'extensive record' (Wood, 1996, p.1) can be provided by art historians, building owners, architects or even citizens and they can all help to provide useful information about the building. The afore mentioned documentary sources might not necessarily have been prepared for conservation records specifically, their original purpose may have been for a different reason, e.g. an art historian's description of a building would have been written with a different intent, for a different audience and with different priorities. However, such records could contribute towards conservation records by imparting their own specific information, which can be used to inform conservation decisions and processes. The identification of historic records is mainly undertaken as a preliminary desk-based research to assess any relevant documents relating to the building and its environment, as Wood (1996) describes it in his article *Record making and the historic environment*. Plans, drawings,

photographs and eventually photogrammetry are likely to be more reliable than the written word as they are less open to interpretation or subject to the author's own interests. However, all existing and available records are of potential use within the field of conservation and therefore valuable for inclusion in the work on historic buildings.

Example: Comparing Images and Examining Information

In order to understand the issues around comparing and examining different sources of information within a conservation project an example of different images collected for one particular historic building are presented below:

Figure 3 (p.57) is a lithograph of the Old Castle in Stuttgart, Germany. It depicts a moment of times past and is similar to a photographic record (albeit with possible artistic interpretation) and therefore represents an impression of what the building looked like in the 18th century and also reflects how the area around it was used.

Figure 4 (p.58) shows the ground plan of the castle. It is a technical drawing, which gives some understanding of the building's original construction.

Figures 5 & 6 (p.59, p.60) are photographs. There are, like paintings, an impression of the building at a certain moment in time but are more likely to be accurate. However, if they were virtual images there is a possibility that they could have been manipulated.

These images are a good record of the castle as they allow the observer to understand its history and gives a good impression of the building itself.

However, some of the changes to the building made over the years may not have been specifically recorded, although by comparing the records from different times,

any further changes may become visually apparent. Figure 4 shows phasing of the castle with the first build which dated back to the 12th century and the last 1810. Therefore Figure 3 dated 1860 shows seven phases. Comparing these two figures with the image shown in Figure 5 highlights the loss of some of the original fabric of the castle which can then be further examined by locating the ground plan (see Figure 4) and comparing it with the image in Figure 5. In Figure 6 the castle is shown as it looks like today. The images and the ground plan present a range of gathered knowledge where the changes and reconstructed areas could be identified. Such analysis of different documents supports the conservation process by highlighting any relevant interventions, repairs or even maintenance work that had to be undertaken over the life of the castle. If further records were available a better understanding of the castle would be possible for example any decay issues caused by the use of different materials for repairs could be highlighted.

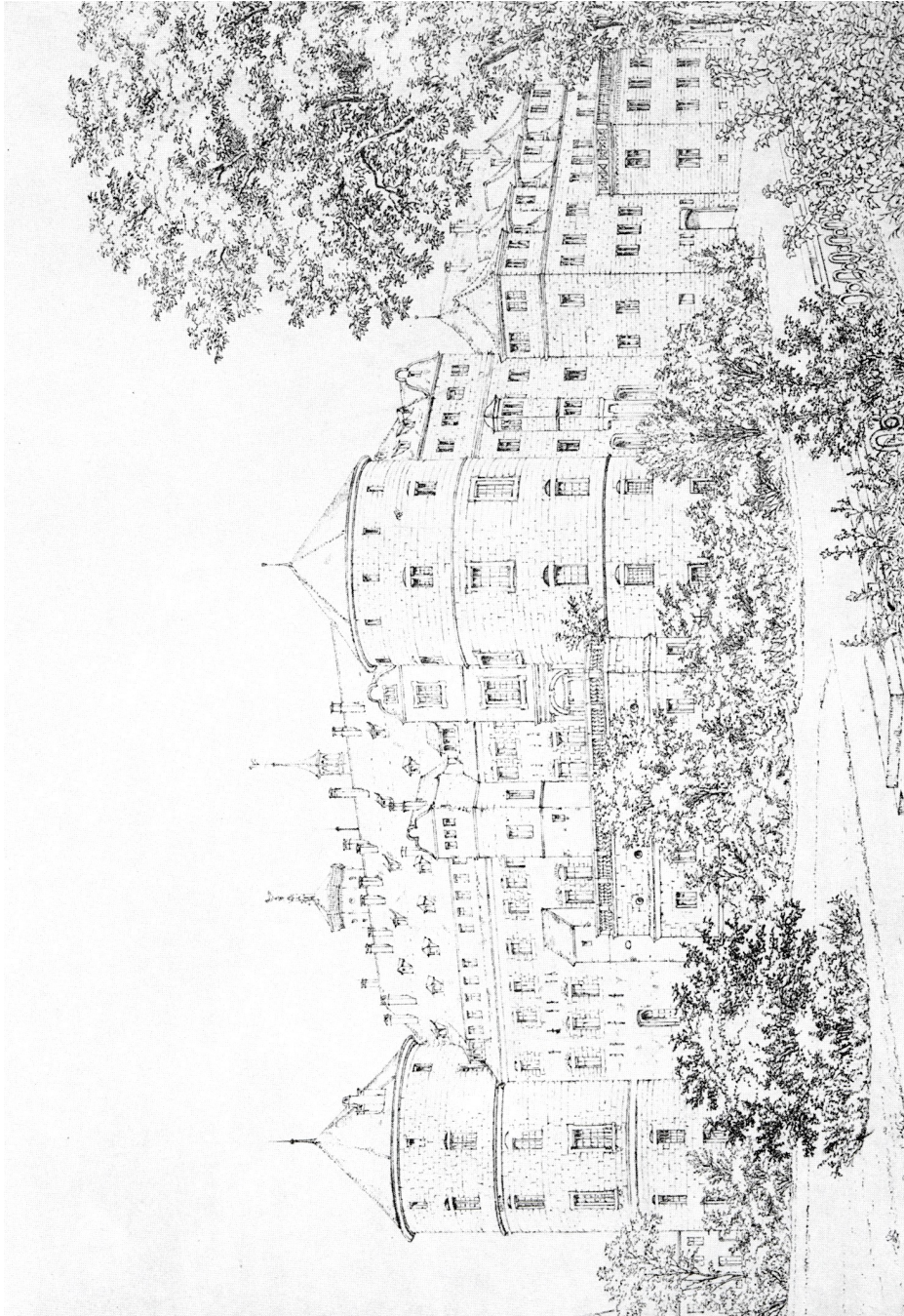

Figure 3: Lithography of the old castle Stuttgart, 1860

The image shows northeast side of the outer walls of the castle.

from Friedrich Keller (Fecker, 1992, p. 15)

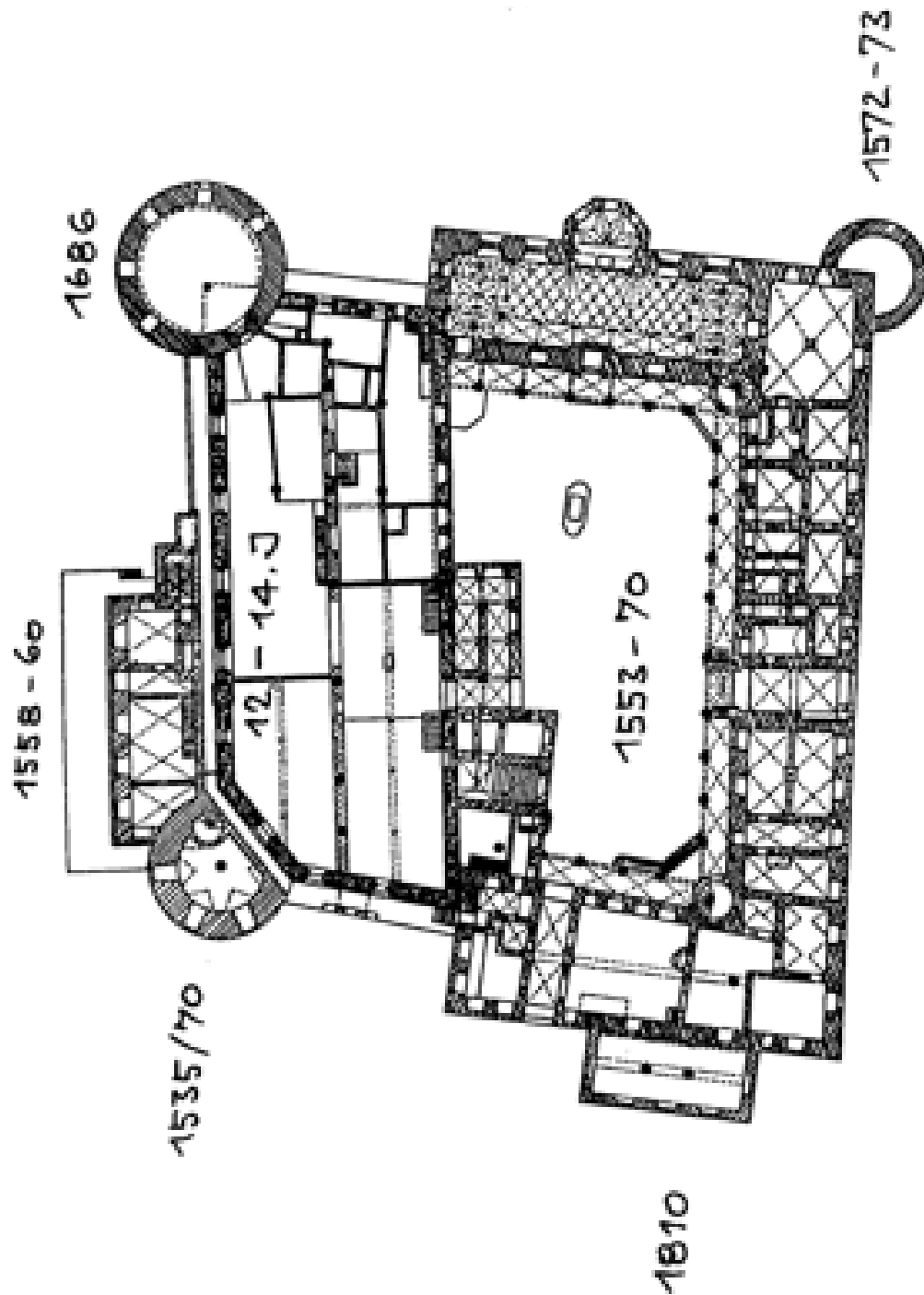

Figure 4: Ground plan of the old castle Stuttgart, Germany

The image shows different phases of the castle from 12th century up to the 19th century. (Fecker, 1992, p. 11)

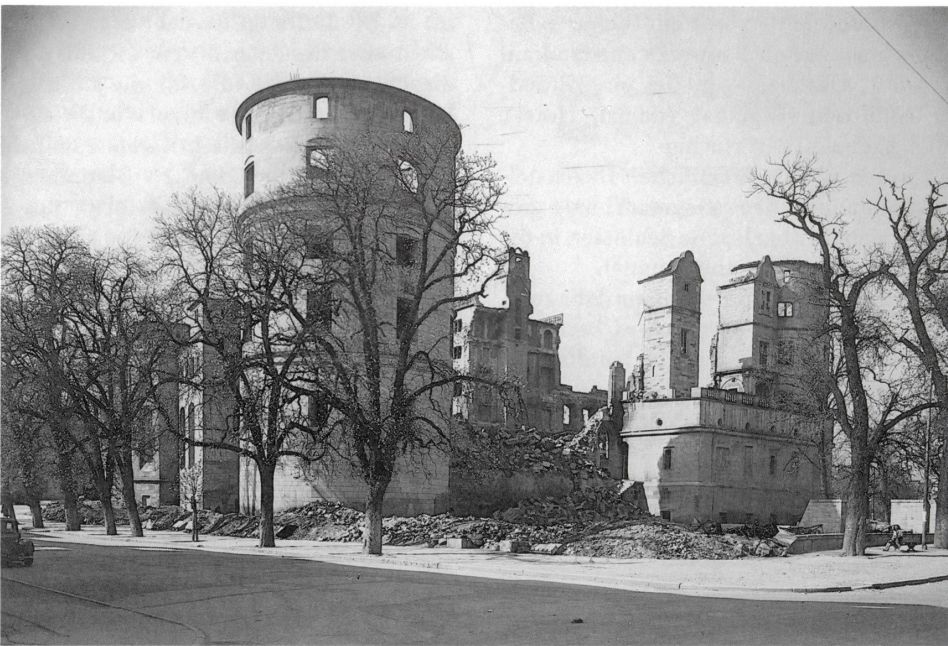

Figure 5: Photography of the castle after the 2. WW, around 1945

Picture above: Courtyard of the castle, picture below outer walls north east. (Fecker, 1992, p. 108)

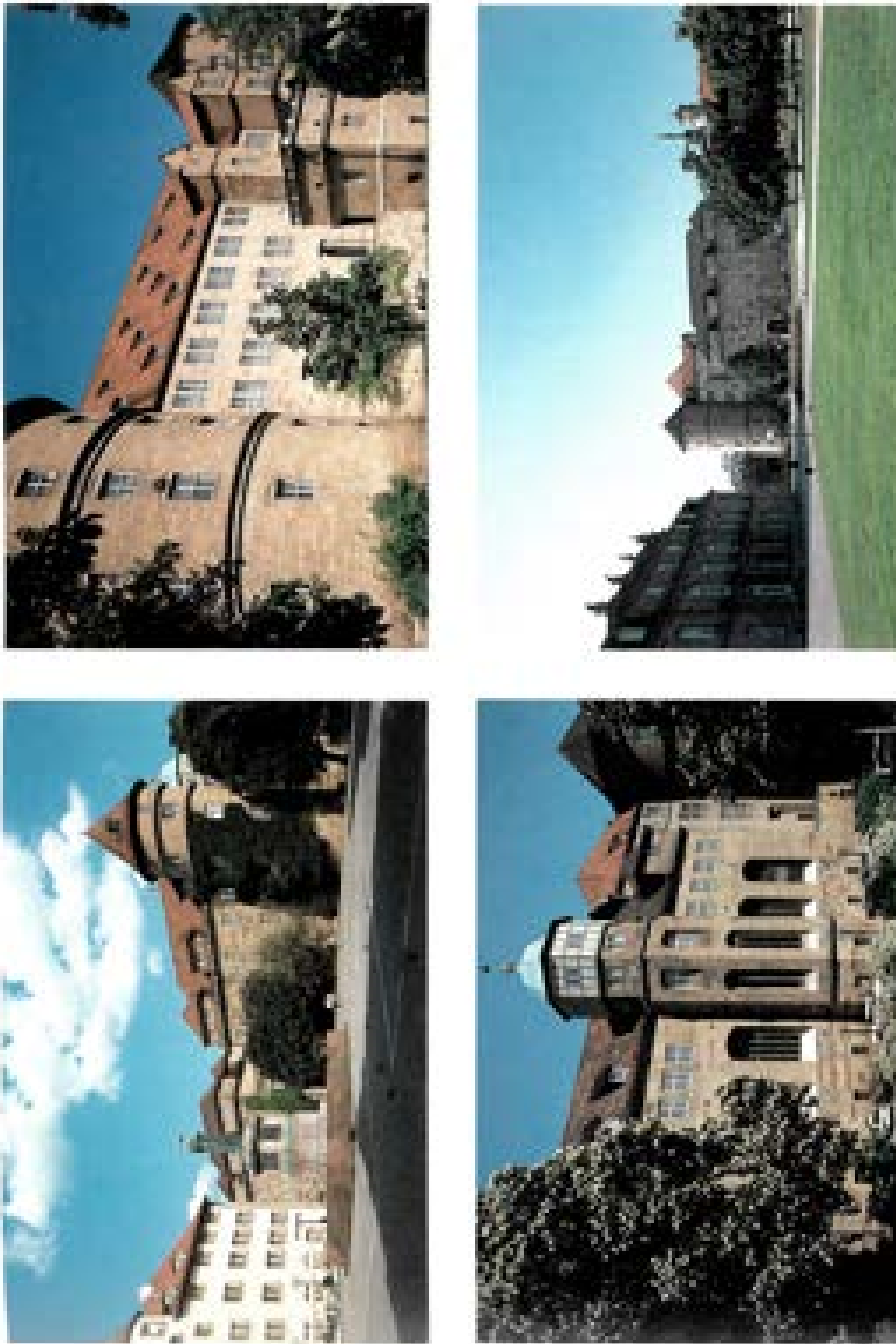

Figure 6: Photography of the castle today

The two pictures on top show the north east facades of the castle (Fecker, 1992, p. 125)

2.1.4. Record – what, when and why

Increasing awareness of the importance of historic buildings and their conservation has made documentation very important. Consequently, recording any work undertaken in the conservation process is essential for maintaining and preserving knowledge about our historic buildings. Before any practical intervention is carried out the building should be recorded as it is found. This includes the investigation of its significance and its condition (Clark, 2004).

English Heritage produced a guide titled *Understanding Historic Buildings: A Guide to Good Recording Practice (2006)*, which was subsequently revised by Rebecca Lane in 2016 and published by Historic England under the same title.

This guide provides answers to questions concerning what, when and why buildings should be recorded. Making adequate records of historic buildings is a requirement of the conservation project planning process. A conservation brief indicates whether or not the record of a building is up to date, describing the circumstances of the building or site and highlighting any missing information (Lane, 2016, p.3, 4). The level of recording is likely to vary, due to the circumstances of the building itself. The guide clearly outlines that any previous records should be identified and considered first and that a record for each building should be specifically defined by a brief (Lane, 2016, p.3). The English Heritage guide provides an overview of the recording levels in Chapter 5 and highlights the importance of evaluating existing records, pointing out their purpose as well as any information requirements which need to be considered carefully (Menuge, 2006, p.3; Lane, 2016, p. 25). The different levels of recording required have been listed

by Lane (2016) and put together in form of a table (Figure 7, p.64), which indicates the information needed for the different circumstances in order for it to be supportive for practitioners.

| Circumstance | Principal need | Level of record | Form of record |
|--|--|--|---|
| Strategic heritage planning at national, regional or local level; studies of landscapes, building types, areas and settlements | Information on the distribution, survival, variation and significance of building populations, defined geographically, typologically or chronologically. Understanding of their evolution, to underpin heritage management decisions and as a contribution to academic knowledge | Typically Level 1 or 2. Building-specific information may be highly selective or variable in level | May make extensive use of external photography, supplemented by written accounts of individual buildings and/or synthetic text. Drawn element may be omitted, simplified, limited to maps or restricted to key examples. |
| Management planning for property portfolios, and for individual buildings or sites | Baseline information on the nature and significance of buildings, providing a foundation for long-term decision-making, and identifying where further knowledge is required | For portfolios, a Level 2 or 3 record, which may vary with the perceived significance of the building; for single buildings or sites, the level may be 3 or 4 | Measured drawings may form an important component, meeting a range of non-historical as well as historical needs. Where buildings form a tight geographical group, or belong to an historic estate, more extensive documentary research may be practicable. |
| Proposed alterations to a significant building | Understanding of the fabric at risk within the context of the building as a whole, and an assessment of its significance. This allows proposals to be formulated and evaluated, and loss minimised. Also a record of what is to be lost, where significant. | Level 2 to 4 depending on the significance of the fabric at risk, and the complexity and current understanding of the building as a whole and of the class to which it belongs | An account of the building (summary for minor alterations, more detailed for major intervention), with detailed discussion of affected areas. Measured drawings are more likely to be required for major alterations. |
| Extensive repairs or alterations to a significant building with complex fabric evidence | Detailed information on the nature and development of the building's fabric, in the context of an overview of its significance, and of the significance of its parts | Level 3 or 4 | The drawn record may be more detailed than the norm, to inform step-by-step decision-making. |
| Catastrophic damage to a significant building (for example major fire) | Understanding of the nature and development of the building's fabric, in the context of an overview of its significance, and of the significance of its various parts | Level 3 or 4, depending on the significance of the building, the extent of loss and safety considerations | Attention will focus initially on areas most vulnerable to loss (debris, charred timber, water-damaged plaster, etc), which may be recorded in greater detail than normal to assist reconstruction. |
| Dismantling prior to re-erection | Detailed understanding of the fabric of the building, and of the craft processes which shaped it | Level 3 or 4 | The drawn and photographic record is likely to be extensive, and will be carried out both prior to, and during, dismantling. The process of reconstruction, including any departure from traditional practices and materials, may also be documented. |
| Proposed demolition | Assessment of the significance of the building and a record of what is to be lost | Level 2 to 4, depending on the significance of the building. The level will be higher than for buildings of comparable significance which are not similarly at risk | In special circumstances, and where resources permit, it may be appropriate to undertake additional recording (including the application of excavation-derived 'finds' techniques) during dismantling, or to elucidate the context or earlier history of the site through excavation. |

Figure 7: Appropriate levels of record

(Lane, 2016, p.29)

Recording therefore entails gathering information in the form of physical evidence, which provides information about the actual physical survival of the fabric of a building and the spaces it defines. The process of gathering this documentary evidence includes investigations of existing reports, sketches, paintings, photographs, maps, plans and surveys, as well as public consultation. Once this information and evidence has been collected and compiled a statement of cultural significance can finally be put together.

The recommendations in the book *Informed Conservation* (Clark, 2001) differ from the definition of the conservation process described in *Technical Advice Note 8* (Bell, 1997, see p. 65). However, both recommendations may be valuable in finding an adequate means of applying virtual imaging to building conservation.

Summary

The actual conservation work starts with the process of planning how to manage the project and researching the building's history. Understanding cultural significance and its value leads to an understanding of the importance of recording and informs the decisions made in order to conserve the building. This process, which is necessary in order to protect our heritage, in an organised and structured manner, now needs to be explained in relation to the role of the conservator. In the context of this research, the conservation process will be looked at in more detail with reference to imaging however, before this can be done, the national guidelines from the UK and Germany will be introduced.

2.1.5. Conservation Process UK

Conservation work is structured in a fundamental course of actions set out in the British Standard BS 7913 which “describes best practice in the management and treatment of historic buildings.” (BSI, 2013) (also briefly outlined Chapter 1, p.22).

Before the British Standard came into action (Dec. 2013) Historic Scotland`s guideline Technical Advice Note 8 *The Historic Scotland Guide to International Conservation Charter* (1997) outlined that before any action should be carried out at a historic building, a strategy for how this will be carried out has to be decided (Bell, 1997). Whilst Clark adopted the idea from Kerr (described on p. 41) and outlined a conservation management plan in *Informed Conservation* (2001), for a better understanding of conservation processes both Historic Scotland and English Heritage have put the conservation activities into a structured form as diagrams and tables to show the stages, which should be followed.

Historic Scotland`s diagram of basic conservation activities (Figure 8, p.67) confirms that before any new developments or changes can be made to a historic building it must first be recorded as it is found. Afterwards an investigation of the significance of the site and its physical condition should be carried out, which includes gathering information from observation and documentary evidence to include existing reports paintings, sketches and other illustrations, photographs, maps, plans and surveys. This is investigated in order to understand the narrative (story) of the site.²⁸ Public consultation is also important and should be considered

²⁸ Definition in Glossary

in order to establish how the public values of a particular building. Finally, a statement of cultural significance²⁹ can be prepared from the analysis of the collated information.

The next step in the Historic Scotland guidelines is described as an action plan, which is frequently called a Conservation Plan. This includes details of what work needs to be carried out, how it will be undertaken, by whom, cost estimates etc. Historic Scotland also refers to the Council of Europe's (1986) recommendation that an interdisciplinary approach to regular exchange of information should be observed throughout a project. All the identified work which needs to be carried out, should be divided into long and short-term actions. The action plan should also include a maintenance plan to avoid any additional major work in the future.

All this work needs to be recorded in the form of documentation to include both pictures and words. This document is then kept in an accessible place for future reference.

²⁹ Definition in Glossary

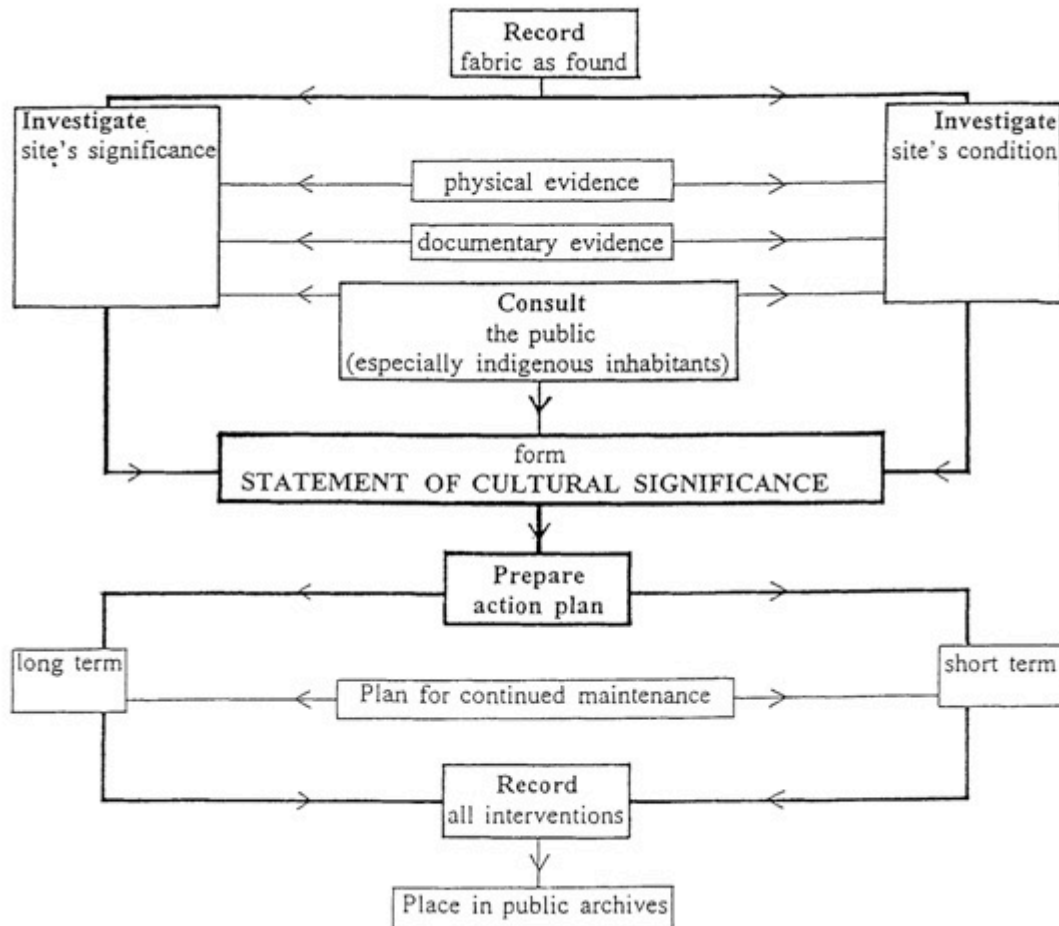

Figure 8: Diagram of the basic conservation activities – Historic Scotland
(Bell, 1997, p. 34)

Kate Clark produced the book *Informed Conservation* (2001) for English Heritage. The book contains guidelines with advice on the contribution that understanding can make to the practical process of conserving historic buildings and their landscapes and more specifically, how to apply that understanding directly to conservation projects (Clark, 2001). Clark (2001) also introduces CoBRA (Conservation-based Research and Analysis), which comprises stages of the conservation process recommended by English Heritage. Figure 9 (p.69), which

outlines stages in conservation based research and analysis is similar to the diagram above (p.67) (Clark, 2004). The outcome of this analysis is a Conservation Plan, which is a guide to future action.

When comparing these two conservation management plans with each other in detail the similarities are obvious even if the information itself is presented differently. The recording pre-action is outlined in detail by Historic Scotland's plan. With these actions the significance of an object can be outlined. This action however, is not outlined in Kate Clark's (2004) plan, because the purpose of this flow chart is to present the stages of a conservation project once the cultural significance has been established within the conservation plan.

English Heritage's action plan is an advice sheet for planners and architects, because it shows whom and at what planning stage each action should be taken, before the actual work can be carried out. The conservation process is also embedded in English Heritage's *Conservation Principles, Policies and Guidance* (2008), which is in turn embedded in National Planning Policy Framework (2012) Section 12.

The Historic Scotland example is specific in outlining how a statement of cultural significance can be achieved and an action plan produced. Both plans are important to keep in mind when working within the field of cultural heritage, because the exact order of when and what should be done to protect cultural heritage is important for the actual work being undertaken to be of the best standard and quality.

Stages in Conservation-Based Research and Analysis

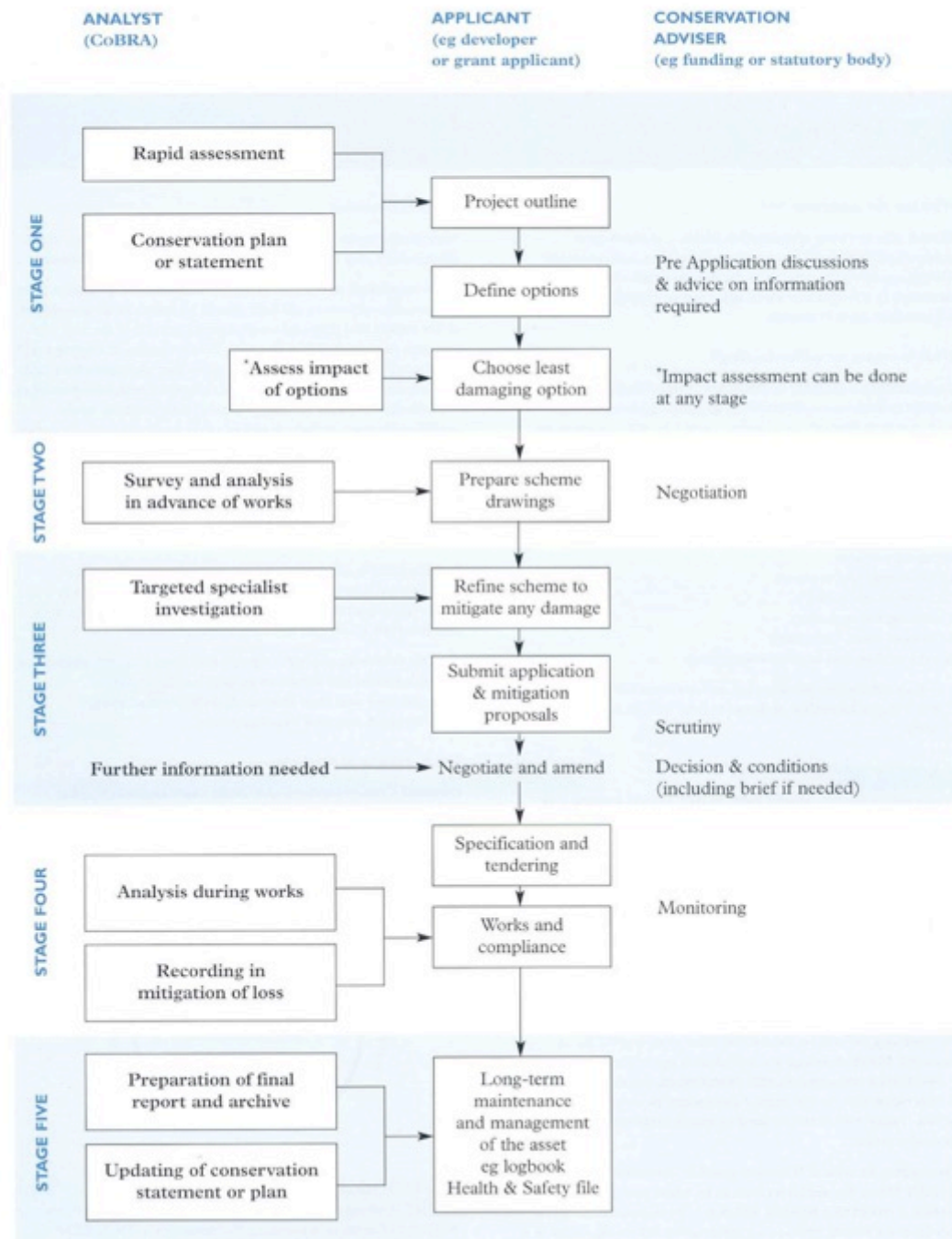

Figure 9: Stages in conservation-based research and analysis
(Clark, 2004, p.2)

2.1.6. Conservation Process Germany

The International Conservation Guidelines that have been written have helped to encourage a national awareness of cultural heritage and its importance. In Germany, the protection of cultural heritage is based on the “Grundgesetz” (basic law). However, the act of protecting cultural heritage is the responsibility of each individual county. Therefore, each county in Germany has established its own law “Denkmalschutzgesetz (DSchG)” (meaning cultural heritage preservation law) which has been applicable between 1953 and 2010. From 2010 onwards, Germany established specific laws for the protection of cultural heritage across the country. However, the agreements of all the counties are described in the monument³⁰ principles. There is a national agreement that all counties share the same principles for the care of monuments. The differences in the individual county regulations are in: the definition of monuments, the system of how or what is protected, relationship between other laws for approval, and areas of responsibility (Hubel, 2011, p.352, 353).

This research analyses two case studies in Chapter 4, which are based in Germany. Therefore, it is valuable, for reasons of clarification, to discuss the standards for the historic assets of the two German counties (Bavaria and Nordrhein-Westfalen) where the chosen case studies are located.

In Bavaria, a law for the protection of cultural heritage was introduced in 1973

³⁰ monument is understood as a historic place, building, etc.

(Staatskanzlei, 25.06.1973), which sets out the principles for dealing with cultural heritage. The institution tasked with the protection of Bavaria's cultural heritage is the "Bayerisches Landesamt für Denkmalpflege" (The Monument Office of Bavaria). In Bavaria, the Charter of Venice (1964) is the basis for the act of caring for cultural heritage and the Bavarian State Office for the Preservation of Monuments is the central specialist authority of the "Freistaat" Bavaria for the protection of historic monuments and their preservation. It compiles the list of monuments, advises and provides information on all aspects of building and art conservation as well as on landscape conservation. It also advises and promotes the projects of the 1300 non-governmental museums. The "Landesstelle" for non-governmental museums in Bavaria is part of the Bavarian State Office for the Preservation of Monuments.

In addition, another organisation focuses upon Bavarian state castles, gardens and lakes however, this authority is not described in this research as it is not relevant for the case study.

The structure of the Bavarian State Office for the Preservation of Monuments is as follows:

- The Department of Monument Collection and Monument Research, which combines the work of: The Monument Collection, the Memorial List, and their documentation and research. This department provides the basis for decision-making and the information base for the practical preservation of monuments in the areas of construction and art monuments as well as for landscape monuments.

- **The Department of Practical Preservation of Architectural and Artistic Monuments**, which includes the care of monuments, and the practical preservation of monuments, buildings and art.

- **The Department of Archaeology**, which includes the care, protection and information of archaeological sites.

The Bavarian Monument Protection Act forms the basis for the work of the Bavarian State Office for the Preservation of Monuments. It not only defines the term "monument", but also describes the correct handling of architectural monuments, ensembles and landscape monuments. The enforcement of the Monument Protection Act is the task of the Lower Conservation Authorities, which is located in the districts and municipalities.

The Bavarian State Office for the Preservation of Historic Monuments is subordinated directly to the Bavarian State Ministry of Education, Culture, Science and Art as a state authority. (Blfd.bayern.de, n.d.)

Northrhine-Westphalia introduced a similar monument protection law in 1980 (Monument Conservation Act) (Ministerium des Inneren des Landes NRW, 1980), which is similar to that of Bavaria and is also largely based on the Charter of Venice (1964).

The monument office in Northrhine-Westphalia is divided into two institutions. One

is “LVR³¹ Amt für Denkmalpflege”,³² which is responsible for “Northrhinepalz” and the other one is “LWL Denkmalpflege”, which is responsible for Westphalia Lippe. The county of Northrhine-Westfphalia is divided into two parts, one is the Northrhinepalz and the other one Westphalia. Northrhinepalz is the east western part of the county and Westphalia is the northeastern part of the county. The case study, Aachener Dom, which has been chosen for analysis in Chapter 4 is located in Northrhine-Westfalia next to the boarder of the Netherlands and Belgium, therefore the institution LVR Amt für Denkmalpflege, is responsible for this area.

The Rhineland Regional Council National Bureau of Monuments (monument office) is the institution, which includes the departments of Inventory, Construction and Artistic Design, Documentation and Restoration.

The essential tasks of the Monument Conservation Act from Rhineland are: to describe cultural heritage, to explore it and in addition to continue to support it and to communicate its value to the public through publications, lectures and seminars. (Denkmalpflege.lvr.de. n.d.)

Each department has its own role however, all relate to the protection of historic monuments. The department of inventory decides which assets are historically valuable for a region. This is directly linked to the construction department which undertakes and oversees conservation work. The department for documentation

³¹ Rhineland Regional Council

³² national bureau of monuments

provides guidance on the documentation of a monument and also the act of archiving.

2.1.7. Comparison between UK and German conservation guidelines

A direct comparison of guidelines for cultural heritage conservation of these two countries is difficult due to cultural diversities and the differences in administrative structures concerning cultural heritage organisations. German counties do not provide tables as shown above by Historic Scotland or English Heritage. However, looking at a conservation management plan from the UK closely, the same attributes are followed by German monument offices, which is to be expected as both countries observe the international charters and guidelines. The structure is laid out as follows:

- Inventory
- Research
- Recording
- Conservation work
- Documentation

British conservation plans are described as: "A document which explains the significance of a site, identifies how that significance is vulnerable and sets out policies for retaining that significance in any new use, management regime or alteration" (Clark, 1999, p.1). Later Clark describes in more detail the need for understanding the building, before changes are carried out to historic buildings (Clark, 2004, p.1). The German approach is close to the British one, especially

when considering the Historic Scotland's *Technical Advice Note 8* (1997), the UKIC Code of Ethics (1996) or the ICOMOS Burra Charter (2013). These involve identifying an object or building as a possible significant site by an Inventory Department, followed by research to confirm the inclusion on the inventory and recording. Following these steps, the action plan, which includes the planning stage as well as the actual work, can be carried out and is put together. These steps are best described as a conservation management plan.

The difference between the conservation management plan in Great Britain and Germany is by its translation into actions. In Great Britain, the clearly defined structure helps to support the professionals in the field to identify each stage and achieve the aims within it. In Germany, the action plan is individually created for each project without guidelines, therefore clear and defined structure in the working process is sometimes missing.

2.2. The relationship between the conservator and the conservation process

In the preamble of the E.C.C.O (European Confederation of Conservator-Restorers Organisation) Professional Guideline, cultural heritage is described as valuable patrimony which should be passed on to future generations (E.C.C.O., 2002, p. 1). It emphasises that significant and valuable historic buildings, objects and assets need to be looked at by professionally trained conservators to assure the best possible protection of the asset (E.C.C.O., 2002, p.2). This organisation compiled the eight levels of the European Qualifications Framework (EQF) for the Conservation-Restoration profession. The eighth level is the highest one (Masters

Level). This system is supposed to guarantee the knowledge and skills of a trained professional, due to their education (E.C.C.O., 2011, p.5). The potential areas of a conservator's work can then be identified within conservation management plans according to the individual's education and experience. E.C.C.O. has outlined, a conservation-restoration process called the spinal step in the booklet *Competences for access to the conservation-restoration profession* (2011). The spinal step is broken down into 7 individual steps (p.78).

The first step is the examination and diagnosis, which assesses the fabric and its condition, analyses the alteration and a risk assessment of the building. The second step is assessing the need, which incorporates the usage of the building. The third step is the assessment of C-R Actions, which includes the activities of the planning and organisation process. This assesses the level of interventions, evaluates the alterations, including the demands, risks and options for future use. The fourth step is planning and organising health and safety, legislation, insurance, project planning, finance, equipment and facilities.

The fifth step is the actual work. This includes remedial measures, restoration and management processes. The sixth step evaluates the outcome, which includes the risk assessment after the treatment, the success of the treatment and the communication of the treatment. It also includes the identification of future actions required to sustain the building. The last step includes aftercare advice and guidelines for future maintenance (Corr, 2011, p. 19).

All these steps point out what a well-structured conservation process should include from the beginning to the end, however very often steps are not in one person's hand and several experts are often involved in order to finish a project successfully.

E.C.C.O outlines the work involved in a conservation process in a diagram (Corr, 2011, p. 20, 21), according to the spinal steps. In these diagrams, the level of knowledge and the skills of a conservator-restorer are highlighted (diagrams are in the Appendix 3). This indicates the competences and knowledge of specialism of conservator-restorer. Understanding the approach of conservation management plans, at what stage virtual imaging can support conservators' work and the documentation of cultural heritage, is part of the methodology of this research.

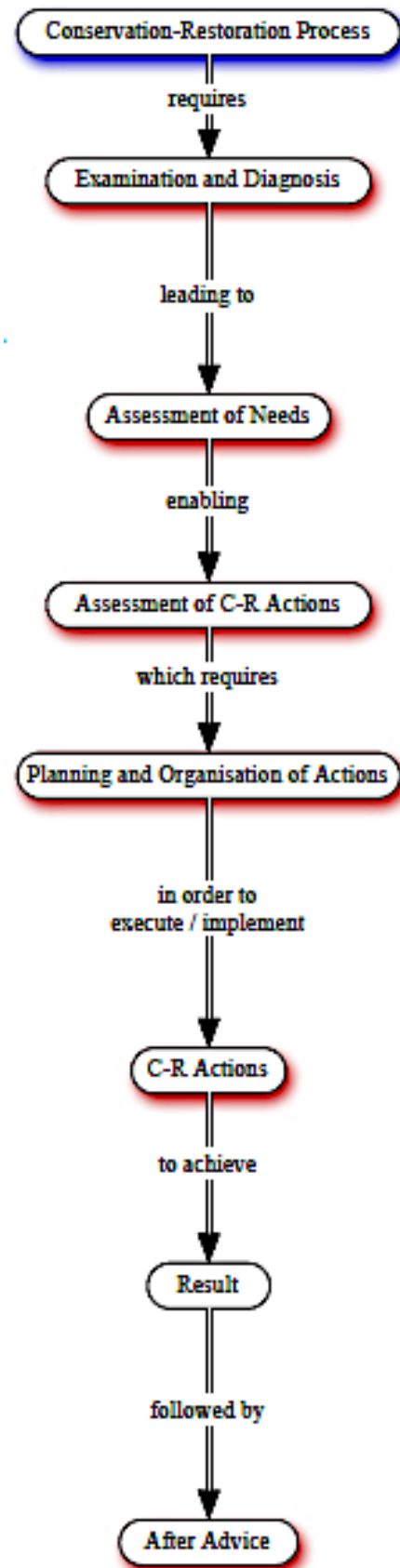

Figure 10: Spinal Steps

(E.C.C.O., 2011, p. 19)

2.2.1. Comparing the tables from HS, EH and E.C.C:O

How the conservator is integrated into the conservation process is always dependant on the skills of the individual (Appendix 3).

The conservation process that is explained within the three tables above: Historic Scotland (Figure 8, p.67), English Heritage (Figure 9, p.69) and E.C.C.O. (Figure 10, p.78) have important similarities.

All the following steps and stages, dependant on the table, are comparable. The difference within the tables is the focus and the depth of description. It seems that Historic Scotland's table focuses on the recording and documentation only. The E.C.C.O. spinal steps focus on the task of a conservator, which includes recording, however this is not explicitly mentioned in the diagram. The table of Historic England is more detailed in its description of the work.

The single steps or stages are described within the following list, which has been created as a method within table 1 (p.86) to relate the work of the conservator to virtual imaging. The numbering was adopted from English Heritage's table, which was developed in 2001.

1. Capturing information:

The very first stage for understanding historic buildings are research, which includes archival research for historic material about the building as Clark states (Clark, 2001 p.75, 76). That involves gathering knowledge about a building, identifying, analysing and collating records (written evidence, pictures,

photographs etc.) to develop an understanding of the history of the building and the changes it has undergone over time. Understanding the building's history is essential in order to establish its value. This knowledge assists in the preparation of a statement of cultural significance. Historic Scotland's table recommends starting with recording the building as it is found and in the second step to investigation its significance. Historic England's stages are not explicit mentioning the investigation of significance, nor does the E.C.C.O. spinal steps. This is an important difference between the tables. The spinal steps describe the work starting within a designated historic building as does English Heritage's and Historic Scotland's table.

2. Analysis:

The diagnosis gathers information about the actual condition of the fabric of the building through, for example, a scientific analysis of the materials to understand the construction and to identify any damage, or causes of decay. This is the first stage of the E.C.C.O. spinal steps combined with the examination of the building. Historic Scotland's table puts this into the second stage as well and it is called an assessment of significance. Historic England also describes this as the second stage.

3. Diagnosis:

Diagnosis in the E.C.C.O. table (Figure 10, p.78) is placed within the first step, which combines the analysis of the fabric and the creation of a diagnosis.

However, step 2 in the E.C.C.O table, the *assessment of needs*, can also be included in this stage. It also includes an outline of the current use and the planned future uses (E.C.C.O., 2011, p.19).

In English Heritage`s table (Figure 9, p.69) it is the third stage, which involves an evaluation of the gathered information of the building.

Within Historic Scotland`s table (Figure 8, p.67), this stage includes a statement of significance.

4. Action plan:

Planning and organisation of actions, is the fourth step of the E.C.C.O. table (Figure 10, p.78). It includes the preparation of the action and also considers the risk assessment, which includes health and safety, legislation, insurance, project planning, finance and equipment and facilities. (E.C.C.O., 2011, p.19).

Note: In English Heritage`s table (Figure 9, p.69) steps 3 & 4 mentioned above are included in one stage called stage 3.

5. Conservation Work:

This is when the actual conservation work is undertaken (E.C.C.O., 2011, p.19).

This includes the protection of the existing fabric according to a risk assessment produced in an earlier stage (3). This will include temporary intervention, which should be carefully designed and implemented so as not to damage the existing building and is in accordance with current conservation guidelines. This action is stage 4 in the English Heritage`s table (Figure 9, p.69)

and recommends monitoring and analysis of the work together with recording.

6. Documentation:

The conservation work undertaken should be recorded and assessed on completion of the project. On going recording of actual work in a written form illustrated with photographs is also recommended together with guidelines for future care and maintenance. This is the seventh and last step of the E.C.C.O. spinal steps (E.C.C.O., 2011, p. 19) and part of stage 5 on English Heritage's table (Figure, 9, p. 69). It is the on-going recording of the actual work in written form illustrated with photographs. This stage is listed as stage 4 in English Heritage's table.

2.2.2. A Summary of the Conservation Process

The process described above shows the structured phases required when planning conservation interventions for historic buildings. British Legislation and Guidance thoroughly considers the context of cultural heritage with the intention of determining effective interventions. Germany has not yet developed such clear structures. Each county administers their actions independently and therefore may be carried out differently. As a result, there is no general diagram that can be compared with the British system (interview with Ulrike Heckner, LVR, Germany, 2016). The working processes described within the illustrated tables and in words from HS, EH and E.C.C.O. support the method for considering images within conservation management plans. The stages described explain the action of the conservation team members including the conservator's recording methods and

outcomes. Therefore, Table 1 (p. 86) has been developed to illustrate the stages at which, according to English Heritage's conservation management plan (Clark, 2001), imaging of any type may support conservation work.

2.2.3. Imaging within the conservation process

Table 1 (p. 86) is an attempt to coordinate the work of a conservator within a team of experts involved in a conservation project. The table includes details of where images are used within the process and therefore an assessment of how useful the virtual imaging is within the conservation process can then be evaluated.

The description is not specific about which profession has carried out this work, however, according to a diagram provided by E.C.C.O. (2011) (see Figure 10, p.78, and see Appendix 3), a conservator could be involved at any of the stages listed below.

In the first stage "*Capturing information*" historic images are helpful in the analysis of what was there before and how it has changed over time. Phase drawings, ground plans, paintings or even photographs can help to identify the history and previous state of a building. Different professionals such as such architectural/art historians, architects, archaeologists and conservators may be involved in this stage. The conservator can use the historic material for understanding the building and its fabric. It supports the restoration with details such as ornamentics on the façade or a specific colour scheme for example. At the same time, the building surveyor starts to capture the dimensions of the building.

The gathering of all the information captured from sources such as archives,

monument offices, local libraries etc. will help the conservator to understand and interpret the building and progress to the second stage.

The second stage “*Analysis*” involves, in terms of conservation work, a close examination of the buildings` fabric and condition, to include colour scheme etc. It also involves images in the form of ground plans and elevations, which can be used for mapping the fabric’s condition to support the analysis of the building. The dimensional/metric survey of the building from this stage informs the work of the conservator, because mapping decay or investigative findings such as colour schemes are recorded on these survey drawings and they are also an effective way of presenting the information to the main contractor and the client.

Other disciplines such as scientists are helpful in understanding the condition of the fabric and its components, which may help in finding solutions for the conservation work. The conservator can support the scientist with information, which may have been gathered from pictures (stage 1), but certainly from mapping the decay.

In the third stage the project manager such as the architect or the monument officer must carry out a “*Diagnosis*”. This is the stage where the problems within the building are presented. All the accumulated information gathered by all the professionals involved must be discussed within this stage, to help understand the buildings state at the time, identify the problems and how they may have changed over time. These outcomes will inform the appropriate conservation philosophy and

the subsequent action plan.

After the first three stages, which gather information in order to understand the building and inform the appropriate philosophy, the fourth stage the “*Action plan*”, which is called in the E.C.C.O. spinal steps the *Planning and Organisation of Actions*, has to be developed to determine and achieve the intention of the project.

In this stage, the interventions are designed and specified while monitoring and maintenance strategies are proposed. Images allow the architect and monument officer to visualise the original object as it may have looked in the past and help identify the necessary interventions and to inform the intentions of the action plan.

A ground plan with changes, a virtual image with a colour scheme or extensions can help to decide on the potential interventions for the object.

During the fifth stage the “*Conservation work*” is carried out and this needs to be recorded. This should be documented as the work progresses using photography, drawings or mappings, which can be understood as monitoring (see Figure 8, p.67).

Following completion of the actual work, the final “*Documentation*” phase of the work forms the final project stage. This information is required to inform future maintenance work. It clearly shows the changes affected by this latest work scheme.

| Stage | Historic Building - Actions | Recording Methods | Action carried out by | Imaging |
|--|---|---|---|---------|
| 1. | Capturing information about the object/ building/ place (Data collection) | Surveying of building; Research documentary evidence, historic pictures, photographs, etc. | Conservator | Yes |
| | | | Building Surveyor | Yes |
| | | | Architect | Yes |
| | | | Architecture/ art historian | Yes |
| | | | Archaeologists | Yes |
| | | | Monument officer | Yes |
| 1 | Interpretation and presentation of collected data | | Conservator | Yes |
| | | | Building Surveyor | Yes |
| | | | Architecture/ art historian | Yes |
| 1 | Dimensional/ metric Survey | | Conservator | Yes |
| | | | Building Surveyor | Yes |
| | | | Architect | Yes |
| 2. | Analysis | Analysing the building by surveying in terms of the condition of the building Risk assessment | Conservator/ archaeologist/ architect | Yes |
| 3. | Diagnosis | | Bringing together all the results of each single profession: architect; officer HS etc. agency funders | Yes |
| 4. | Action plan | Conservation inventions | Each profession provides an action plan, which needs to put together to one by the architect, monument officer has to agree | Yes |
| 5. | Conservation Work | | Conservator/ craftsmen etc. | Yes |
| 6. | Documentation | | Conservator/ etc. | Yes |
| Table 1: Conservators work in relation to a conservation process (K. Schütte, 2015) | | | | |

Table 1 (p.86) illustrates that at each stage of the process images can support the conservation work. Looking in more detail at the six different stages, each step might require a different kind of image. These steps support the understanding, planning and finally the actual work.-However, all the research work required during stage 1-3 take time and involve different professions to provide useful information.

Therefore, the initial parts of the process must be included as part of the project budget.

2.3. Summary

Comparing two countries and their attitudes towards cultural heritage is not easy, due to the cultural differences, disparities in legislation and the variable structures of the offices responsible for overseeing the work. However, European countries have agreed to observe international principles, guidelines and charters, which provides a common base across the continent. The heritage work in the UK is well structured by guidance from English Heritage or Historic Scotland for example. The tables (Figures 8 & 9, p.67 & p.69) are intended as guidelines for the professional groups working in this field, and provide a clear understanding of how objects should be cared for. These are valuable for the generations now and in the future. In Germany however, a clear overall structure is missing, although each single county has its own guidelines. These guidelines find their base in the international Charter of Venice (1964), which provides a common base structure and understanding of cultural heritage.

In Nordrhein-Westfalen, there are separate departmental responsibilities for each stage of the conservation process. For instance, the inventory department is responsible for what will be protected. However, the significance of cultural heritage is a shared responsibility.

The European Confederation of Conservator-Restorers` Organisation recommends a reliable process in *Competences for Access to the Conservation-Restoration*

Profession, 2011, which is similar to the structure of the conservation plans given by Historic Scotland and English Heritage.

2.4. Conclusion

Having outlined the stages of a conservation project it has really become clear how important structured work is in protecting cultural heritage. The conservation management plan, the philosophy and the process of recording and documenting the building or object are really important in the care of our cultural heritage. The stages of a conservation process help to identify the different recording and documentation processes required and are especially useful in identifying the potential role of virtual imaging. The stages mentioned in this chapter have helped to identify the type of information a single image supports within a conservation project and also supports the decision about whether this would be appropriate information for communication by a virtual image. This discussion will continue in the following chapter.

CHAPTER 3 – Virtual and Digital Modelling Techniques

3. Introduction

For the purpose of this research, virtual imaging and virtual image have specific meanings as defined in Chapter 1 p. 4. Virtual imaging is computer-based process, which involves the non-physical reconstruction of a phase or moment in time. It is a visual documentation tool, which also incorporates information about an object, building or place for instance historical information, future changes and interventions etc. Whilst a Virtual Image is the chosen phase or moment in time.

Whilst digital is a generic term which refers to an image of a physical object generated by a computer a virtual image in comparison is also a digital image which incorporates additional documentation to present a hypothesis of an object such as colour scheme, earlier phase or other details. Both terms – virtual and digital – are used analogous in this research. All the virtual versions are based on research and should not include conjecture, illusion or fake ideas. The advantage of having additional information about an object apart from what is obvious, images can often be supportive in conservation work. Aspects of what might be useful in terms of additional information will be discussed and explored within paragraph *3.1 Overview of IT based techniques used in architectural conservation* under the following subheadings:

- i.) When is virtual imaging appropriate? An overview of whether virtual imaging is appropriate for conservation work;
- ii.) Capturing data – the different methods of capturing data and their

possible outcomes;

iii.) Creating a digital image – current techniques used in the creation of digital images;

iv.) Presentation – an outline of the different forms of presentation possible using IT based techniques and a discussion of relevant examples, which have been created in the context of conservation work.

Paragraph 3.2 *Workflow* analyses the methods of imaging.

Paragraph 3.3 *Examples of the use of virtual imaging* discusses a variety of examples, which have been chosen from several sources to include; the internet, work experience of the author, case studies from academic papers presented at conferences and case studies from Historic England. These examples all use different techniques and methods of virtual imaging. By examining these case studies and examples, the intention is to use them as a way of further discussing and exploring the specific technologies currently used in architectural conservation.

Finally, paragraph 3.4. *Conclusion* compares and analyses these different examples within a table. The table also compares the outcomes of each example and analyses how useful each style of recording and documentation is for each object.

3.1. Overview of IT based techniques used in architectural conservation

In Archaeology, 3D modelling has been in use for a long time compared to the length of time it has been used in building conservation. Therefore, the tools that are used and their outcomes are more precisely understood within the

professional field of archaeology. Attempts within the field of archaeology to push 3D documentation beyond graphic and photographic data is growing and the outcomes so far seem promising (Stanco et al., 2011). This is surely due in part, to the usage of GIS and the laser scanning of archaeological sites, which can then be exactly located and measured. The data from the laser scanner may also allow the possibility of a virtual reconstruction, as it can successfully transport information and data such as measurements. This range of collected data from a particular site, allows the archaeologists to become more informed about the site and therefore understand it in a more precise way.

Due to the extended experience of virtual methods within the field of archaeology and the breath of techniques used, the knowledge gained is therefore more sophisticated. Building conservation work could therefore also benefit from advancement in knowledge of IT based technologies. However, the author is not aware of any current documentation or writing concerning this exchange of knowledge between the two fields, but this potential exchange could certainly be considered as an area for future study.

3.1.1. When is virtual imaging appropriate?

Virtualisation was described by Graziano in 2011 as using computing to create something which does not physically exist (Agrawal, 2016, p.340). The image itself cannot be touched or felt although the device or computer of its creation does exist. However, Graziano recognised that the advances in IT technology means that the range and precision of information collected in the creation of a virtual reconstruction, can produce an authentic presentation of a building.

Nevertheless, caring for cultural heritage means dealing with existing physical objects and buildings, which are considered significant for humankind.

Considering the existing wealth of knowledge about these historic buildings the question about why and for whom a virtual image should be created should now be asked. A definition of the purpose of the creation of a virtual image also needs to be considered. Grellert divides the use of IT technology in the context of cultural heritage into two different spheres a *reconstruction for a scientific discourse* and *an interesting presentation of historic buildings for the public* (Grellert, 2010, p. 189).

When looking at virtual reconstructions within cultural heritage from the perspective of a conservator, the first point in the above definition is crucial. Through the visualisation of the various findings from the research of a building a discussion can then take place, and a hypothesis can be approved or abnegated. A digital reconstruction of a building is based on the information collected beforehand and this gathering of information can include all types of sources, records and documents. Assisting in the development of an understanding of a particular building by surveying and researching it, the conservator (according to the conservator's experience as mentioned in Chapter 2) is able to support the conservation process as part of a team of other professionals involved in the creation of a virtual image. Before this can take place all the professionals involved in a historic site have to decide whether a virtual image is supportive for the on-going conservation work or not. When considering the conservation process, as discussed in Chapter 2, it is clear that several stages can be supported by the creation of images. Documentation, for example, producing accurate survey drawings, with the aid of digital tools such as CAD and terrestrial scanning allows an exact record of the existing building

or part of a building to be created. This record can support the process of repair, as well as document the history of the building. Virtual images showing the past phases of the building can also inform the conservation process by suggesting how the building might have been originally constructed or altered in the past.

This is not to suggest that these past layers of fabric should be removed as they are part of the building's history, however, if they are considered insignificant any demolition work can be informed by what is likely to be located beneath and therefore not put this fabric at risk. Likewise, any repair or intervention work into the existing layers can be designed to avoid damage to what might be hidden beneath. Monitoring – which can be done by using different techniques such as scanning is a process concerning the location of the exact repairs. When repeating this scan the repairs can then be compared over years and therefore immediate work could be carried out before greater decay takes place.

Therefore, this technique may help to reduce the overall costs of repair.

The effectiveness of virtual imaging production should also be considered within the conservation process. Its production should support the actual conservation work, inform the knowledge base concerning the historic building and should also be a good record of the building. Finally, and perhaps most importantly, virtual imaging technologies, should always be appropriate for the building concerned and fulfil the aims set for the protection of cultural heritage.

In the following paragraph the different methods of creating virtual images are discussed and put into context.

3.1.2. Capturing Data

Various techniques are required for producing an accurate digital image, in order that the image can transport useful information in the form of a record, which is then able to support and enhance the conservation process. Two of the techniques currently available are explored under the following subheading.

3.1.2.1. GIS and BIM

GIS is described as a system, which includes hardware, software, data and people. Its purpose is to describe spatial data and information data. Therefore, GIS could be used as a cultural heritage management tool. Having the possibility of collect different data from different sources such as metric surveys, archive investigations or monitoring and be able to interpret this data in one system is a useful tool for managing cultural heritage (Stylianidis and Remondino, 2016, p. 108, 109).

Considering GIS as a documentation tool for cultural heritage, due its ability to link data together in one project, the information could then be used and interpreted by different disciplines.

The most important thing in the use of GIS, is the planning of the project beforehand. Anyone involved in a GIS project needs to develop a defined strategy for any data collection and data entry (Stylianidis and Remondino, 2016, p. 111). As described in Chapter 2, the professionals within a conservation project must work together and therefore the effective communication between each professional involved supports the outcome of the project.

BIM was originally developed for use with new buildings. It was designed to

support the architect and any other professionals within the team in the creation of a virtual, 3D representation of the building or object. The types of data, which can be stored in this type of virtual modelling include buildings geometry, spatial data and the properties and quantities of components used (Stylianidis and Remondino, 2016, p. 114).

In order to use BIM in the field of cultural heritage, first of all a 3D model of the building is required, which includes a metric and cognitive survey in the form of a graphic, visual and iterative visualisation. When this information has been collected, several models can then be created to present possible changes or plans to manage the object in its current state. BIM technology can therefore be used as phase study, which includes ontology.

The use of a combination of GIS and BIM technologies allows a non-geometric and a geometric database to be put together. This combined method might offer potential as an effective documentation tool for cultural heritage in the future.

However, at the moment, as mentioned by (Stylianidis and Remondino, 2016, p. 124), there is still a long way to go in order to achieve BIM as a possible tool for heritage documentation. An example of a BIM model will be presented later in this chapter.

1. Scanning

Laser scanning/ scanning is a technique, which captures information from an object, or building and the accurate measurements produced support the documentation of the physical building. The dimensions and structures may be better understood by using the collected data and information from the scans, and therefore the conservation process and analysis of the object is supported. With the three-dimensional measurements in the form of point clouds, ground

plans or cross sections can also be produced with the aid of CAD software.

Accurate plans of the building could support conservation work as presented within the case study under the sub heading *3.2.3. Metric survey* (p. 100). A three-dimensional recording produced through 3D laser scanning is described in the Guidance Note: *3D Laser Scanning for Heritage*, (English Heritage, 2011, p. 3).

This document points out how important accurate measurements are for recording historic buildings. Different results can be achieved by different scanning techniques, as illustrated in the diagram from Böhler presented at the CIPA symposium held in 2001 (English Heritage, 2011, p. 7). The diagram outlines the three-dimensional survey techniques characterised by scale and object size and (Figure 11, p. 98) gives a rough idea of which tool can be used for which size of the area or building to capture data.

To achieve a successful project outcome, it is very important to use the right technique.

Figure 12 (p.99) presents a list of different scanning systems, its uses, together with their accuracy and operating range.

The accuracy of a scan is dependent on the scale of the object and the scanning system used. Small objects can be scanned with more accuracy due to the distance (operating range) between the scanner and the object.

Triangulation-based scanners reach an accuracy of up to 50 microns by 0.1-1m operating range. Laser scanners such as terrestrial laser scanners, which are used, for scanning building facades can reach an accuracy of up to 5mm to an operating range of 50-100m. The accuracy scanners and laser scanners can achieve is impressive and therefore the measurements only ever have very

small mistakes.

Guidance Note: *3D Laser Scanning for Heritage* (English Heritage, 2011, p. 7), describes the three ranging principles on which the scanners operate:

- triangulation
- time of flight
- phase comparison

Triangulation is a 3D technique, which is based on optical triangulation. It is a combination of an active and a passive method, and produces direct and indirect measurements.³³ Time of flight refers to a system, which uses the travel time of a pulse of laser energy in order to calculate the range.³⁴ And the phase comparison scanner bases its measurements on the range of the differences of the emitted and returning laser pulse.³⁵

³³ Definition in Glossary

³⁴ Definition in Glossary

³⁵ Definition in Glossary

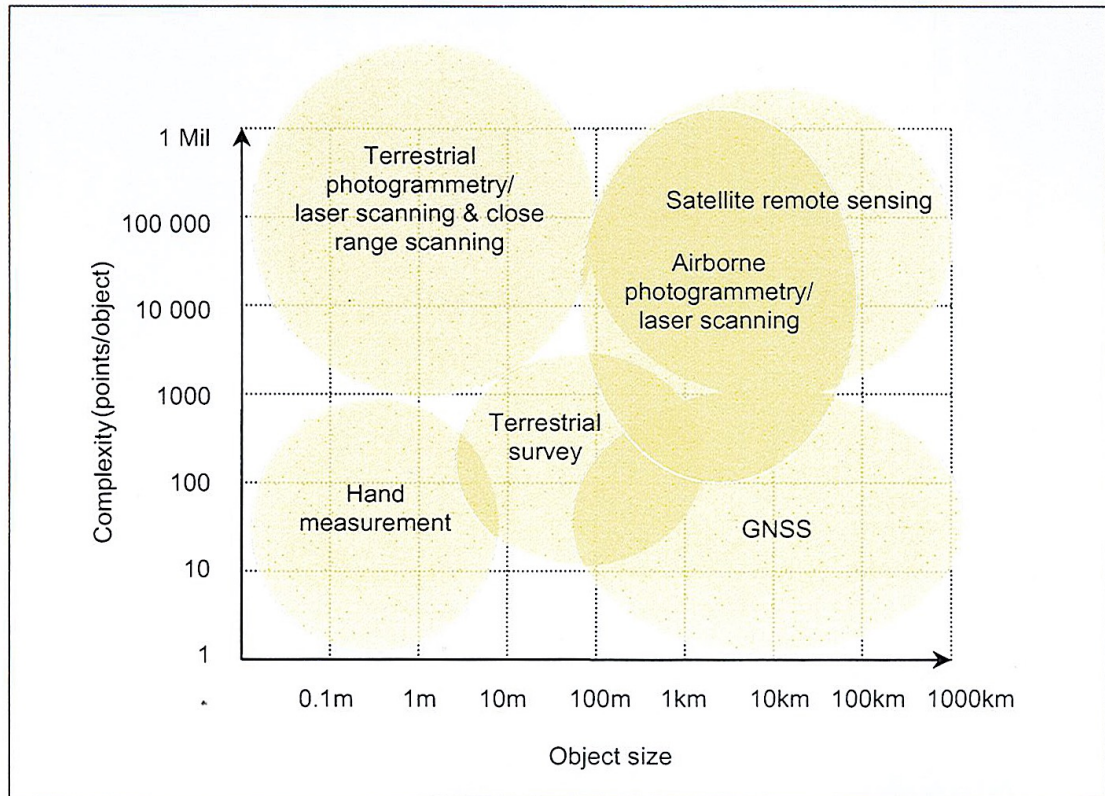

Figure 11: THREE-DIMENSIONAL SURVEY TECHNIQUES

Characterised by scale and object size

Derived from Böhler presentation CIPA Symposium in 2001, Potsdam (English Heritage, 2011, p.3)

Table 1 Laser scanning techniques used in cultural heritage management activities

| scanning system | use | typical accuracy / operating range | |
|---|---|---|----------------------|
| triangulation-based artefact scanners | rotation stage | <ul style="list-style-type: none"> scanning small objects (that can be removed from site) to produce data suitable for a replica of the object to be made | 50 microns / 0.1m–1m |
| | arm mounted | <ul style="list-style-type: none"> scanning small objects and small surfaces can be performed on site if required can be used to produce a replica | 50 microns / 0.1m–1m |
| | mirror/prism | <ul style="list-style-type: none"> scanning small object surface areas <i>in situ</i> can be used to produce a replica | sub-mm / 0.1m–25m |
| terrestrial time-of-flight laser scanners | <ul style="list-style-type: none"> to survey building façades and interiors, resulting in line drawings (with supporting data) and surface models | 3–6mm at ranges up to several hundred metres | |
| terrestrial phase-comparison laser scanners | <ul style="list-style-type: none"> to survey building façades and interiors resulting in line drawings (with supporting data) and surface models – particularly where rapid data acquisition and high point density are required | c 5mm at ranges up to 50–100m | |
| airborne laser scanning | <ul style="list-style-type: none"> to map and prospect landscapes (including in forested areas) | 0.05m+ (depending on the parameters of the survey) / 100m–3500m | |
| mobile mapping | <ul style="list-style-type: none"> to survey highways and railways for city models to monitor coastal erosion | 10–50mm / 100–200m | |

(adapted from Barber, DM, Dallas, RWA and Mills, JP 2006 'Laser scanning for architectural conservation', *J Archit Conserv* 12, 35–52)

Figure 12: Laser Scanning Techniques

(English Heritage, 2011, p. 7)

Scanning techniques vary a little in their detail, however all the aforementioned tools collect the required information as point clouds. The next step is to bring the point clouds from one object together in one piece, using the so-called registration process. Afterwards, the information gathered from the point clouds is more useful when it goes through a process called geometric modelling. In this process the point clouds are converted into a mesh. These points can then be used to extrapolate the shape of the subject (a process called reconstruction).³⁶ If colour information is collected at each point, then the colours on the surface of the building can also be determined. Scanning cannot capture the colour itself, but reproduces the surface. Analysing the flakes of paint, which remain on the surface, allows the right colour to be established. Laser scanning can collect information about the surface of distance objects. The information, which is collected as points, allows the identification of the three-dimensional nature of the surface by collecting many scans and finally bringing them together in a common reference system. This process of alignment is the basis for merging and therefore the creation of a model.³⁷

3.1.2.2. Photogrammetry³⁸

In addition to the various scanning techniques currently available, cameras can also be used to produce 3D models. The most obvious differences between these two methods are that cameras collect coloured information and scanners collect dimensional information. Photogrammetry is also a tool used for producing digital images, which transport useful information about a building.

³⁶ Reconstruction in this context means that the points do form finally a shape which reconstruct the building

³⁷ Definition in Glossary

³⁸ Definition in Glossary

Using targets on the object can use 2D images to produce precise 3D coordinates and this information can be used to create 3D models. The disadvantage of white strip scanning only in comparison to photogrammetry is that the white strip scanning works reliably in dark surroundings and it has to be tripod mounted. (exactmetrology.com, n.d.).

Photogrammetry in comparison to laser scanning is far cheaper and also delivers the texture of the object. With the technique of photogrammetry orthophotos³⁹ can be produced, which means that an image can be produced without distortion and is also true to scale.

Imaging photogrammetry is one process which needs to be mentioned as a useful tool for producing virtual images for documentation purposes. By taking a lot of pictures of the asset with a DSLR (digital single-lens reflex) or DRS (digital reflex camera) camera, the 2D data can then be calculated and converted into 3D points by using *structure from motion* (SfM) tools. SfM describes the process of the 3D surface calculation with 2D image data from different perspectives.

The pictures, which have been taken, are then sorted into an image structure by photogrammetric algorithms.

There are two main methods used for photogrammetry:

- Aerial photogrammetry⁴⁰
- Close-range photogrammetry⁴¹

Aerial photogrammetry is used for example in cartography, environmental studies, and archaeology. The overlapping photographs taken from the air can

³⁹ Distortion-free and true-to-scale illustration

⁴⁰ Definition in Glossar

⁴¹ Definition in Glossar

be put together and a good analysis of the photographed area can then be produced. For building conservation close-range photogrammetry is more useful. With overlapping photographs taken of the building an image-based model can be produced. Photogrammetry is a very useful tool for documentation purposes, because this method captures accurate metric data, which allows stereoscopic reconstruction of an asset by taking different pictures from different positions.

In this section two examples of the use of close-range photogrammetry are listed. These examples show the efficiency of photogrammetry and how much detail can be documented within this technique. It is a useful documentation tool for recording the condition of a surface or structure especially for the use of recording.

Example 1: Vessel



Figure 13: the vessel

The underside of the vessel, photograph - K. Schütte, taken in Pafos 2017

The example used to illustrate photogrammetry, is a small vessel (Figure 13). The author had the opportunity to work with this object at the CIPA summer school in Pafos, Cyprus in 2017. This involved the production of a 3D model using software provided by Agisoft. Here multiple pictures were taken with a DSLR camera. These images were overlapping and taken from different positions to catch the entire object. The images were then uploaded onto a computer and aligned with Agisoft Photo Scan.

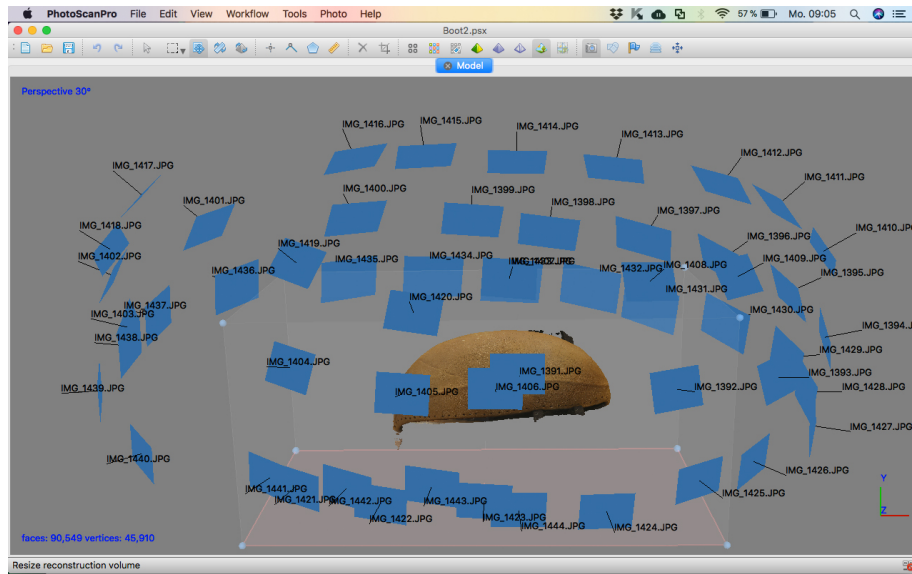

Figure 14: screen-shot from Agisoft Photoscan Pro - image arrangement

K. Schütte, 2017



Figure 15: screen-shot from Agisoft Photoscan Pro

a zoom of the model of the vessel

K. Schütte, 2017

Figure 14 illustrates the image arrangements and Figure 15 show the results of the virtual model of the vessel. The details, which are visible on the surface of the model are a good record of the asset for monitoring and documenting purposes.

Example 2: Wall

In addition to 3D models, photogrammetry is able to produce ortho-images.⁴²

Ortho-images can be useful for recording facades or walls for instance. The example Figure 16 (p.106) shows a wall, which has been photographed with several pictures within a defined distance. The images have then been put together, in order that a ortho-image could be produced.

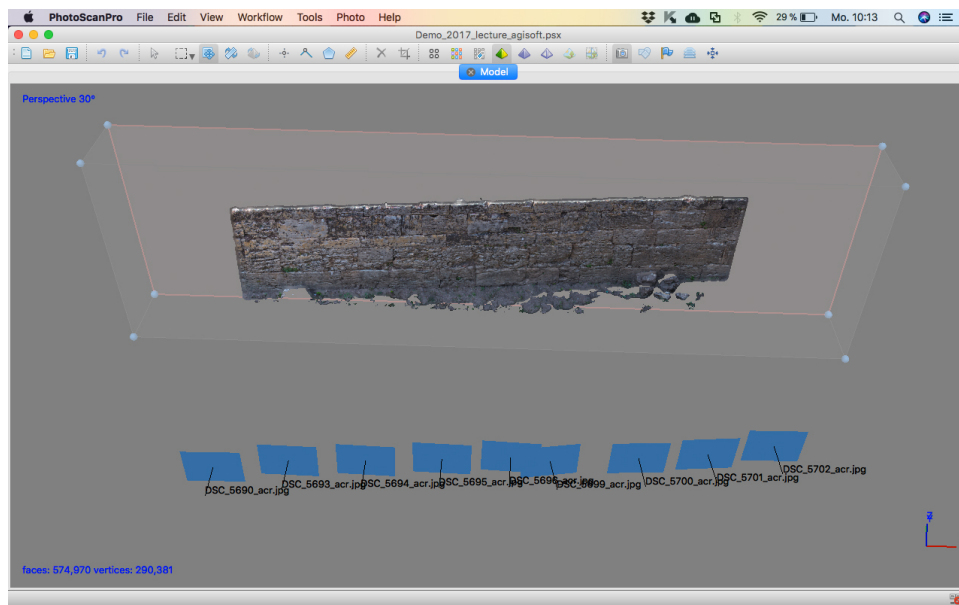

Figure 16: screen-shot from Agisoft PhotoScan, alignment of the images

K. Schütte, 2017

With this image, the wall can be documented and areas which need to be conserved can be marked and according to the conservation process a conservation strategy can be developed.

⁴² Definition in Glossary

3.1.2.3. Software and Hardware

For the technologies mentioned above both software and hardware are necessary. This research does not deal with the technology behind virtual techniques, however to understand the complexity of creating virtual imaging a short introduction to the software and hardware may be useful. English Heritage *3D Laser Scanning* (2011, p.9), describes the software and hardware and this is included in the Appendix 4.

The hardware is the actual instrument which can also be described as a tool.

The scanner, the camera or even the computer itself is the hardware. A specialist contractor usually operates the hardware and the software allows the collected data to be processed.

The different hard and software on the market provides an increasing choice of types and functions as companies make improvements on a regular basis.

However, the graphic card, RAM, disk space, the monitor, and the processor speed and type are also essential for the workstations (English Heritage, 2011, p.9).

Whilst knowing how to use the hardware is crucial, operatives also have to be well trained in using the equipment and understand the software. Regular training should be considered, if professionals are planning to produce records for the future.

3.1.3. Creating and sharing digital image

Understanding the technologies mentioned above, show that they can deliver accurate and precise measurements of a building or site. This is vital for conservation work in particular for recording. However, gathering information is

one issue, but the other issue concerns using the information as an appropriate record or tool for helping to record, document and protect heritage sites. It is important that the data is usable for the professionals who are working in the field of cultural heritage (Cacciotti R., 2015, p. 1).

Considering that different platforms have been created to bring the digitally collected information from heritage sites together and work with this information over several years, a clear exchange of data is still not in place. Museums have created digital archives to make the collections more accessible first of all for their own institutional use, but secondly to curators and visitors interested in the collection. But for heritage sites the exchange and the information platform rarely exist and where they do they are not well known.

Europeana for example is one project, which has been established the following strategic aims in 2011-2015:

- Aggregate – to build the open trusted source for European cultural and scientific heritage content;
- Facilitate – to support the cultural and scientific heritage sector through knowledge transfer, innovation and advocacy;
- Distribute – to make heritage available to users wherever they are, whenever they want it;
- Engage – to cultivate new ways for users to participate in their cultural and scientific heritage.

Between 2015 and 2020 a following up strategy was created, to keep this platform (Foundation, 2012). It is a website, which includes collections and exhibitions from all over Europe. Different countries and museums upload the collections and make it accessible to everyone on the internet. Looking for a specific object via the search button can then be easily found. This platform is a good start for better access to cultural heritage.

The aim of creating digital/ virtual platforms for exchanging historic values

internationally is becoming more and more important for heritage. One answer might be within the building information modelling and semantic web technologies. Peter Pawels believes:

“... BIM applications allow end users to model a building not simply in lines, but in terms of the semantics of its constituent building elements...” (Pauwels, 2014b, p.1).

Qualitative Information - where useful information about a building or a site can be gathered by using BIM could then be made available for the professional world by using Semantic web technologies. Both technologies, BIM applications and semantic web technologies give information of what is behind the surface. This is done with parametric BIM objects, which are geometric, non-geometric information linked with documents and data.

Semantic web technology is an addition to the surface data collected by any metric survey. It is an ontology, which adds knowledge about the cultural heritage by using any terminology. According to Pauwels many examples exist for the usage of semantic web technologies in the creation of virtual heritage artefacts. He refers to the CIDOC⁴³ Documentation Standards Working Group and CIDOC CRM SIG⁴⁴, who agreed to:

“Definitions and a formal structure for describing the implicit and explicit concepts and relationships used in cultural heritage documentation.” (Pauwels, 2014a, p.3).

Documentation of cultural heritage should be available for professionals and therefore it should be globally accessible. Overall the semantic platforms are helpful in order to share and implement other information about cultural

⁴³ Definition in Glossary

⁴⁴ Definition in Glossary

heritage. However, it is not necessarily common that professionals know about such platforms. And therefore, it is not natural that all valid information is gathered. The exchange of information especially at an international level should be a priority, however, the information exchange has to be established nationally first. In the academic world, knowledge about certain platforms might be easily provided, but this information is not disseminated to the professionals in cultural heritage automatically.

An attempt at creating an international database with artefacts has been started, however it is still not completed. However, the establishment of projects such as MONDIS (MONument Damage Information System) does help to inform professionals and make them aware of the possibilities of sharing information about cultural heritage.

One example for semantic web technology is the Finish Culture Sampo (Kulttuurisampo.fi, n.d.).

Not only is the possibility of access to certain information an issue, which still needs to be clarified, but also the issue about copyright must be considered. WIPO⁴⁵ guide for *“Managing Intellectual Property for Museums”* (Pantalony, 2013) includes details about copyright in cultural heritage. The evolving of IT technologies is causing the need to analyse the issue of copyright in regard to the public domain (Pantalony, 2013, p.8).

⁴⁵ World Intellectual Property Organisationsation

3.1.3.1. Introduction to creating virtual images

In Chapter 2 the conservation strategies were explained and in Table1 (p.86) in which stage images are useful for the conservation work has been illustrated.

Some of the tools, which are available for creating IT based images have also been described under 3.1. Overview of IT based techniques used in architectural conservation.

However, there are still questions, which should be answered such as what information should an image transport, which period of time should it display and for whom is the image to be made?

As briefly described in the paragraph 3.1.3. onwards it is important to gather information about an object, creating an ontology, which can help to draw a wider picture of an asset and puts all the relevant information together. The collection of information is necessary in order to understand the building and finally to be able to create a virtual image, a 3-D model or a virtual reconstruction. Gathering all possible information helps to develop an understanding of the building and supports the conservation process (Chapter 2, p.65 onwards).

Other issues may influence the outcome of a virtual image, e.g. personal interpretation of information. Therefore, the professionals involved in the creation of a virtual reconstruction have to be aware of this crucial issue.

Although the key criteria for professionals in the creation of virtual images are that they should be as accurate and authentic as possible (LOPEZ-MENCHERO, 2014, p.6).

3.2. Workflow

The recording of historical objects needs a grounded knowledge of the object itself. Therefore, the research work is the first step as outlined in the conservation process in Chapter 2. A significant object which requires protecting in order to preserve information about our history should be well documented and recorded. By producing appropriate research, the value of the object grows.

When recording a building the intention has to be that the documentation is accurate and reusable, information, which is included must be reliable, the documentation also has to be clear and readable in future. Conservation work and imaging in conservation or cultural heritage should meet these types of expectations, otherwise the document isn't as useful as it should be.

By researching imaging and keeping the purpose of documentation for cultural heritage in mind, the image should contain useful and reliable information.

After gathering and collating all this information, putting it together and identifying a date for each discovery or at least attributing it to a period of time of the building can be established and decision about what will be presented in the virtual image has to be made.

Recording a historically significant object means that certain specific questions should be answered prior to the actual work beginning, they are:

- What should be recorded and why?
- Who is the end-user for this record?
- Which information is necessary?

- How can the record be stored and be reusable for the future generations?

At the start of each project the outcome of the scan data has to be clearly defined. The questions mentioned above have to be considered and put into relation to each project. Each data such as scans can be proved and supported by additional measurements. This action and the workflow is described in figure 17.” (English Heritage, 2011, p.11).

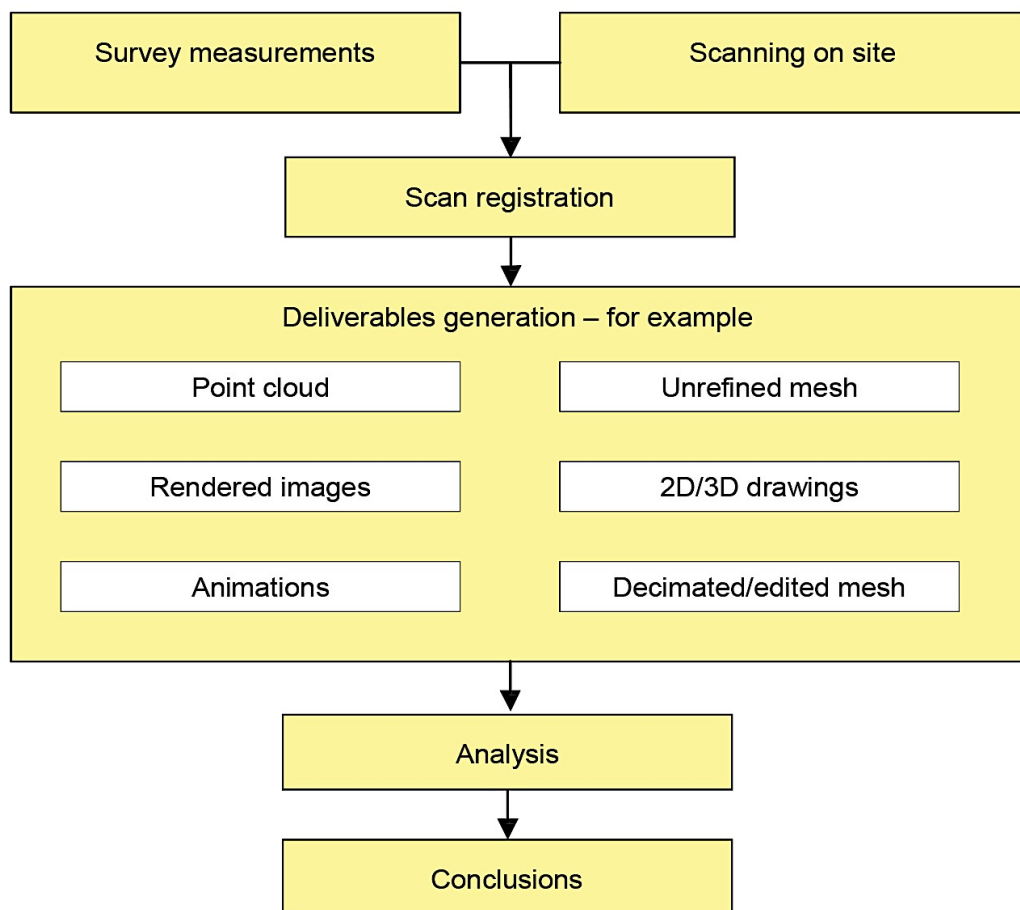

Figure 17: A typical laser scanning workflow
(English Heritage, 2011, p. 11).

In summary, the most important phases of recording cultural heritage are:

1. Understanding the object by identifying and reviewing the documentation in addition to surveying the building.
2. Putting all the collected information together and creating a model.
3. Making visual what is an interpretation.

3.3. Examples of the use of virtual imaging

“Various computer technologies are used to record, preserve, or recreate artefacts, sites, and actors of historic, artistic, religious and cultural significance and to deliver the results openly to a global audience in such a way as to provide formative educational experiences through electronic manipulations of time and space.” (Pauwels, 2014a, p. 1).

The creation of an image can be achieved through various different methods, as discussed in the previous section (p. 65-71). However, the use of different methods can result in very different outcomes. Considering that architectural conservation deals with real buildings, not objects in an enclosed environment such as those in a museum, access to cultural heritage sites through the internet could be the easiest and cheapest way to make them more available to more individuals. As Pauwels points out if this were to happen the overall educational aspect of cultural heritage may be widened. The following examples have been selected in order to explore the information aspect⁴⁶ of a virtual image as a supportive tool within the conservation process.

Today there are many examples of virtual reconstruction. The chosen examples, listed below, were selected from a range of sources to include: internet-based research, English Heritage (2011) *3D Laser Scanning*, conferences and some personal work experience obtained by the author:

- Ishtar Gate of Babylon, Berlin, Germany;
- The Temple of Demeter, Naxos, Greece;
- Hotel Engel, Switzerland;
- Iron Bridge, Coalbrookdale, UK;
- The Book Tower of Ghent, Belgium;
- The mosque of Aleppo.

Each example above has been selected to represent various problems, which

⁴⁶ information aspect – what information a virtual image may present

can arise through the use of virtual imaging in the context of conservation. For example, one of the problems that might occur with the use of virtual imaging is when virtual images are presented out of the context, which may lead to a false interpretation of the object. Also, without any existing documentation a virtual image cannot be produced as a record of the building as a combination of previous documentation and an up to date record is necessary to create a reliable and accurate virtual image.

The Ishtar Gate of Babylon is an example where the object was rediscovered through archaeological excavations and the remains were moved away from the original location and reconstituted⁴⁷ to a museum environment. It has also been reconstructed⁴⁸ virtually. This example was selected in order to consider an object, which has been successfully reconstituted in a museum environment. The ontology of this object is very significant, because it represents an important part in the history of a particular culture.

The second example in this chapter is the Greek Temple of Demeter, which is a straightforward example of a reconstruction, possible because the architecture of Greek temples is already very well known. Again, this example has a major ontology, and when analysing the findings revealed it also appears to still have some secrets to discover. It should demonstrate the ease with which some buildings can be reconstructed when cultural heritage has been thoroughly researched such as the Classical Language of Architecture.

The third example, of a phased study, shows the different stages of the history

⁴⁷ reconstituted means to rebuild with original materials

⁴⁸ reconstructed means to rebuild with non original materials either new or reused from elsewhere or more recently digital data hence a VI can be a reconstruction but never a reconstituted

and development of a former hotel in Switzerland. The history of the building itself was well researched so the phases could be presented in the form of drawings and photographs and with all this information it was possible to create a digital drawing of the development of the building.

The fourth example, the Iron Bridge at Coalbrookdale, UK was chosen because it is part of a UNESCO Heritage Site and the virtual modelling associated with this project. This was created for several reasons, which supported not only the repair of the bridge but also the wider educational aspect.

The Book Tower of Ghent is an example, which was chosen as it has been reconstructed by using BIM and semantic technology. As the fifth example, it clearly illustrates what can be achieved through the use of these tools and what information a virtual reconstruction can transport which may help to better understand the building itself. Finally, the sixth example was chosen for photogrammetry. This example illustrates the achievements with photogrammetry.

The chosen references cover different areas and allow a discussion on the value of IT based tools for cultural heritage documentation. All the examples give different views of virtual reconstruction of cultural heritage, which can be linked to the case studies later in this research (Chapter 4). Table 2 (p. 118) is putting the examples next to each other for analysis reason of the examples. It allowed a comparison especially of the issues related to their production.

| NAME | WHAT | WHY | WHEN | FOR WHOM | BY WHOM | ISSUES |
|----------------------------------|--|--|---|--|----------------------------------|--|
| Ishtar Gate, Babylon, Iraq | Ancient entrance to city of Babylon. 575 BC. | To experience the gateway in its original city context | No date | Visitors to Pergamon Museum, | Digitale-Araeologie.de | Reliability of image/ which sources were used? 3D experience? |
| Temple of Demeter, Naxos, Greece | Sacral building in a rectangular shape. 530 BC | To experience the temple | Reconstruction 2002 | Visitors to the site | Digitale-Araeologie.de | Photorealistic presentation of the surface. Was it never painted? Objects on the roof? |
| Hotel Engel, Switzerland | Hotel from around 1642 to 1912 | To analyse the evolution of the hotel | 2010 | Conservator, architect | W. Odermatt | Phase study according to the findings through documentations and paintings – interpretation? |
| Iron Bridge at Coalbrookdale, UK | Bridge, 1779 | Recording, mapping and scaffolding design | 1999 | Architect, conservator, visitors – educational aspect | Commissioned by English Heritage | Costing? Communication in the team of experts? |
| The Book Tower of Ghent, Belgium | Book Tower, 1933 | To analyse the BIM and semantic web technology | 2014? | University | Pauwels, et al | Reliable information from former documentations? BIM model accurate? |
| Great Mosque of Aleppo, Syria | Great Mosque minaret, 8 th century | Explore photogrammetry as a documentation tool. Due to the destruction | 2015 on going from pictures taken from 1999/ 2000 | Committee for maintenance and restoration of the Great Mosque in partnership with the Engineering Unit of the University of Aleppo | Fangi & Wasbeh | Images from over a decade ago had to be used. |

Table 2: Comparison of examples
K. Schütte, 2017

Looking at these examples will support the exploration of the two case studies in Chapter 4, (p.158).

3.3.1. Virtual Presentation of Ancient Heritage

Example 1: Ishtar Gate, Babylon

The Ishtar Gate, which was “stolen” by German archaeologists after WWI has been rebuilt in an artificial environment by removing its components piece – inside The Pergamon Museum in Berlin, Germany. This museum dedicated to Asian culture is located on Berlin`s Museum Island. A copy of the “stolen gate” has also been reconstructed in its original environment in Babylon. A reconstruction of the gate in the form of a model has also been made by the Pergamon Museum, Germany, because only parts of the gate could be rebuilt within the museum itself. Most of the parts are in storage, therefore the reconstructed model presents the entire greatness of the original gate but does not show its context. A virtual reconstruction of the gate has been modelled by digital archaeology.

The Ishtar Gate⁴⁹ was constructed under the reign of the Babylonian King Nebuchadnezzar II around 575 BC. It was the entrance into the city of Babylon. Its name came from the Babylonian goddess Ishtar, to whom the gate was dedicated. The walls of the gate were highly decorated with sculptures of different animals, that were symbolic representations of different deities. The materials which were used to decorate the gate are glazed bricks and tiles. The

⁴⁹ Brief history Appendix 5

path through the gate led to the temple of Marduk. The buildings of Babylon collapsed and vanished under hundreds of years of desert storms after the city declined.



© Rex Features

Figure 18: Excavations of the ancient city

Resumed after the end of World War I (RexFeatures) (Ruggeri, 2015)



Figure 19: physical Reconstruction of the gate

US and Polish troops used the archaeological site as a base after the 2003 invasion of Iraq, causing extensive damage (Rex Features) (Ruggeri, 2015)



Figure 20: Ishtar Gate in the museum Berlin

Neo-Babylonian | Ishtar Gate | 604-562 BC | Berlin State Museum | Vorderasiatisches Museum, Staatliche Museenzu Berlin | Image and original data provided by Bildarchiv Preussischer Kulturbesitz; bpgate.picturemaxx.com/webgate_cms (The Artstor Blog, 2014)

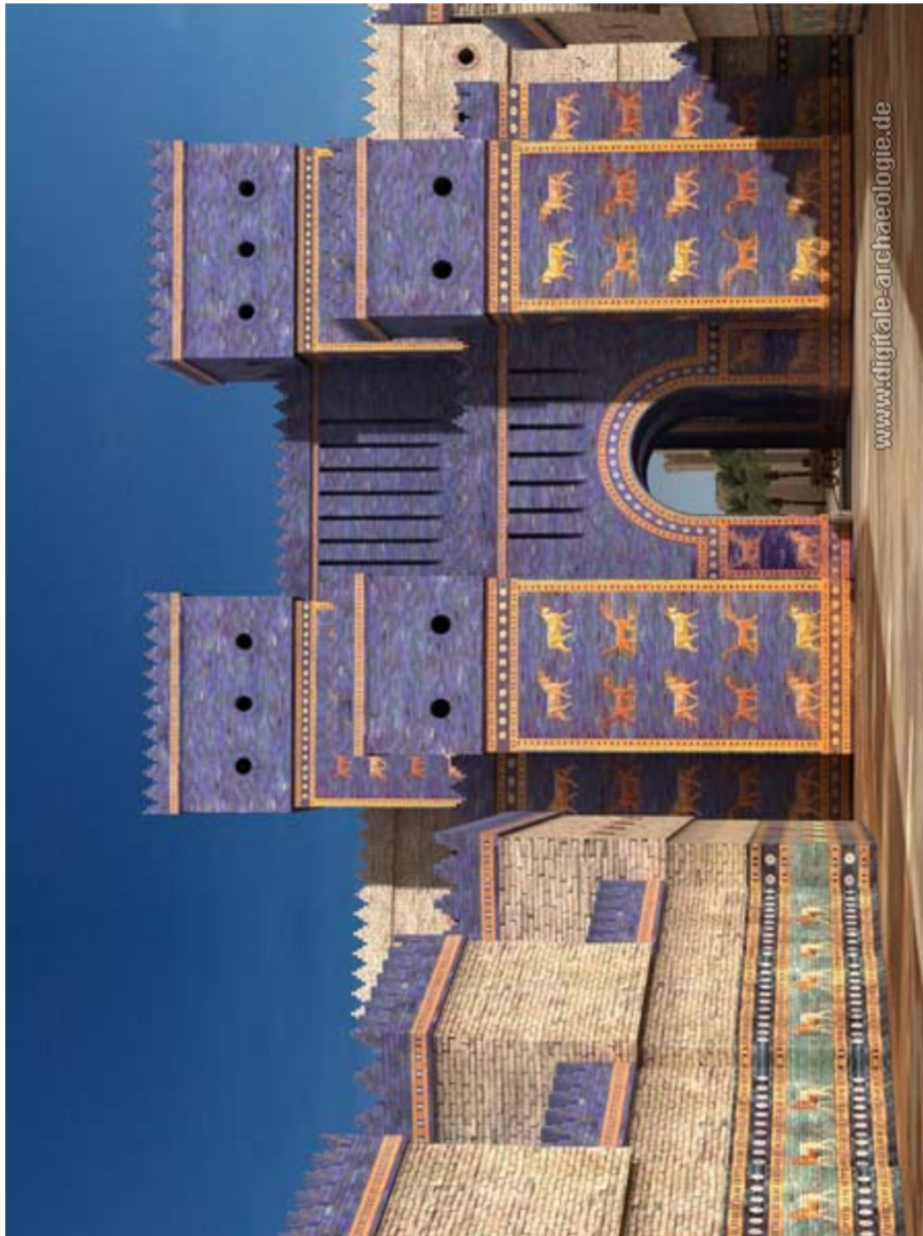

Babylon (Iraq), The Ishtar-Gate and the Processional Route
Construction stage at the time of King Nebuchadnezzar, beginning of the 6th century B.C.

Figure 21: virtual reconstruction of the isthar gate
(Matthias Link, 2014)

Figure 18 (p.121) shows what remained of the gate and its surroundings after the World War I. It was partly excavated in 1899 by archaeologist Robert Koldewey after he noticed brightly coloured fragments on the ground. Most of the fragments of the gate were still there until they were taken to Berlin.

Therefore, the fabric, which has been used in the Museum in Berlin is made up of the original fragments, which were taken to Berlin. The author is not aware of a precise documentation for each fragment, however, it is known that Koldewey documented the excavation as a whole.

Figure 20 (p.123) is a picture from the Vorderasiatischem/ Pergamon Museum, Berlin where parts of the gate have been reassembled. This figure presents a physical reconstitution of original parts of the gate from Babylon.

Next to the reassembled gateway is a physical model of the gateway put in the museum. This model (Figure 22, p. 126, Figure 23, p.127) allows the visitors to examine the greatness of the Istharr Gate on a smaller scale.



Figure 22: physical model of the gateway
Made by A. Hummel year is unknown (1930?)

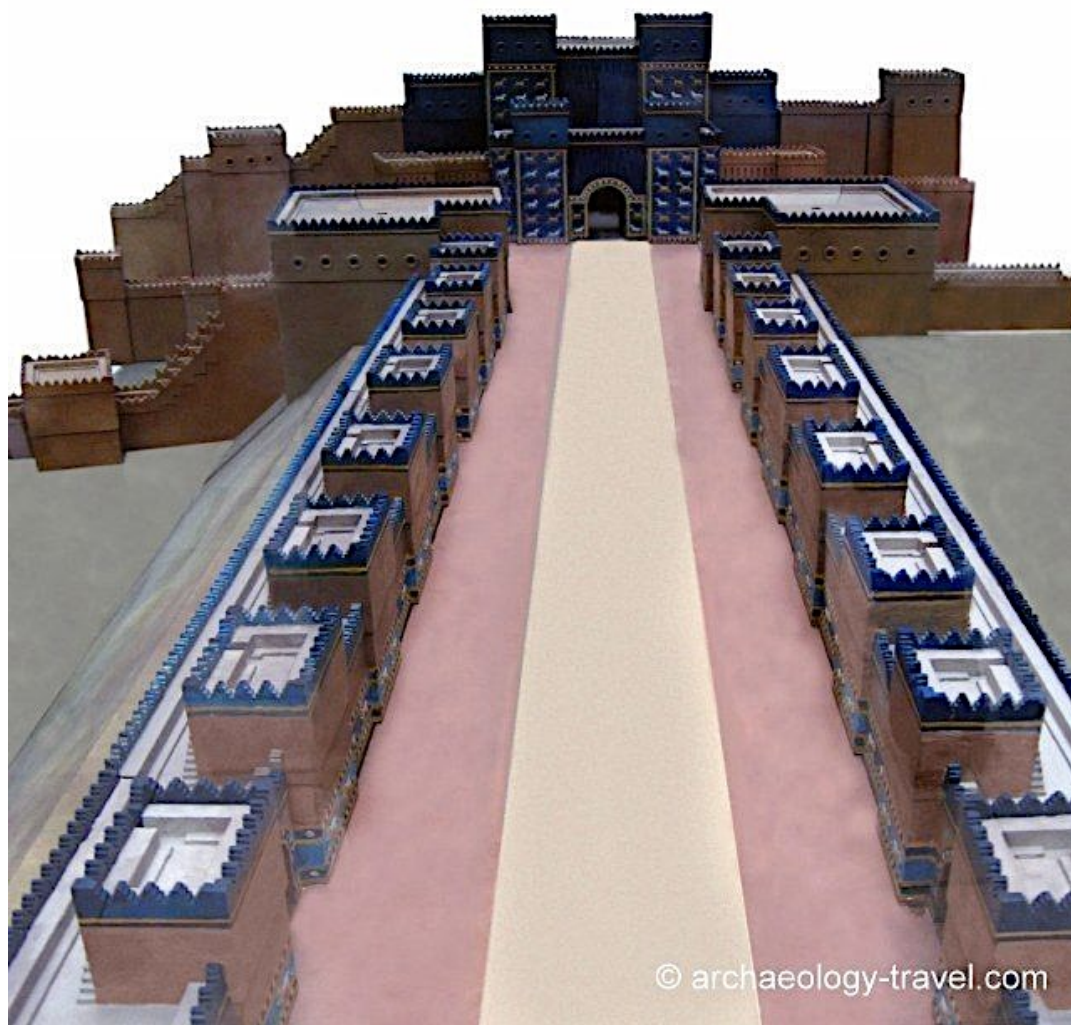

Figure

23: physical model of the gateway
(Dowson, n.d.)

Figure 21 (p. 124) is a virtual reconstruction of the gate and its surroundings as it might have looked originally. The 3D model gives the museum's visitor an opportunity to visualise walking down the processional way towards the gate.

Figure 19 (p.122) is another reconstruction of the gate, however it is a physical reconstruction close to the original site. The size of the reconstructed gate does not correspond to the original size.

This example presents four different ways of reconstructing cultural heritage.

The physical reconstruction, which took place in Iraq itself, which does not appear to use the original dimensions or any of the original materials.

The reconstitution, which took place in Berlin in the museum presents just a small part of the gate itself. It may be the most accurate representation given that it is built from the original bricks, however whether all the materials are original or placed in the same position as they were originally in the building will depend on the accuracy and recording involved in the deconstruction process.

By not knowing the exact number of fragments and the methods of documentation associated with the reconstitution of the gate in the Museum, the amount of conjecture required cannot be identified and discussed in this research. However, it is known that the gateway was reconstituted in smaller dimensions than the original due to the lack of space at the museum. However, information boards with photos, drawings and text have been used to explain the process of reconstructing the gateway.

The virtual reconstruction of the gateway (Figure 21) gives an impressive view of the gateway and its surrounding, which allow the viewer to grasp a feeling of what its surroundings might have been like. However, this image can only be accurate if the context was carefully recorded. The narrative and documentation

concerning the gateway, which have been gathered over several years will need to have influenced the reconstruction otherwise it will not tell an accurate and therefore authentic story about the gateway. The dimensions of the virtual reconstruction may be more accurate than the reconstitution of the gate in Berlin if sufficient documentation was made available giving its actual size. The physical reconstructed model of the gateway and the processional way (illustrated in Figures 18 & 19) were made by E. Andrea Hummel and were photographed by Gryffindor 2007. The author was not able to find out the exact date the model was made, however one indication found on the Artstor Blog. (2014)⁵⁰ suggested that the model dates back as far as 1930. According to Artstor (2014) the design of the layout of the gateway was guided directly by the knowledge gathered from the excavation and the documentation that had previously been carried out. However, whether this physical model is completely accurate cannot be said for sure.

The virtual reconstruction of the gateway is in, the author opinion, based on the physical images that were available. Whether this virtual reconstruction is an accurate representation of the original gateway however is difficult to establish as there is not enough virtual documentation available to verify this.

Nevertheless, this virtual reconstruction does allow people to experience the gateway without travelling to Berlin.

⁵⁰ Artstor is a nonprofit organization committed to digital collection solutions for universities, museums, schools, and libraries worldwide

Example 2: The Temple of Demeter, Naxos, Greece.

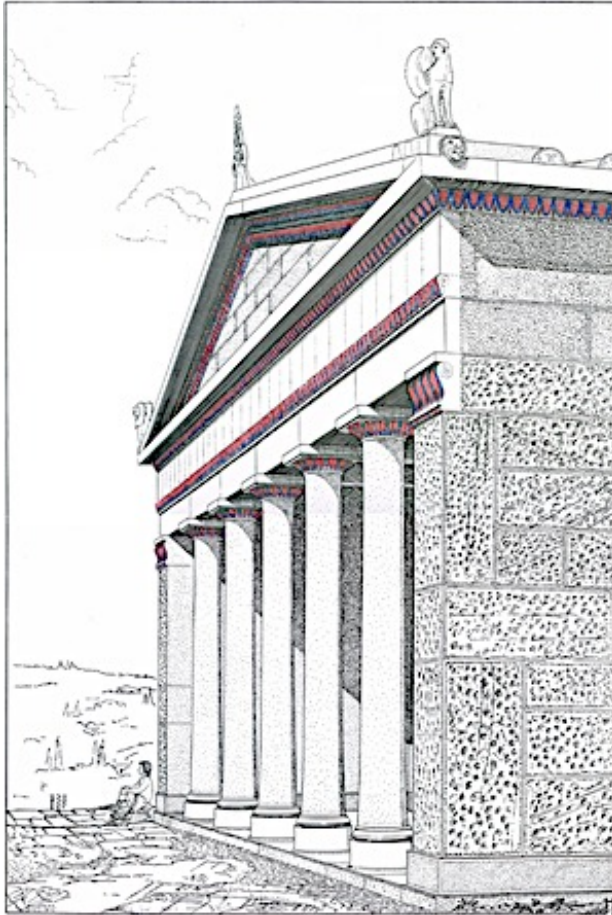

Figure 24: Drawn reconstruction: View of the Temple of DemeterSangri from south-east, with original painting

(M. Korres, A. Ohnesorg) Aenne Ohnesorg, *Naxian and Parian Architecture, General features and new discoveries*, in: M. Yeroulanou – M. Stamatopoulou (Hrsg.), *Architecture and Archaeology in the Cyclades. Papers in honour of J. J. Coulton*. BAR Internat. Ser. 1455 (2005) 140 fig. 4

Ancient Greek architecture has been researched intensely and consequently there is a good understanding of its methods and practices. The history of the Greek temple typology is one of perfecting the aesthetics of the building according to the agreed classical language of architecture with minor changes to the form. This makes Greek temple architecture relatively predictable, even if there are uncertainties in understanding the architectural detailing, the basic structure and shape does not often change. The temple of Demeter was built in 530 BCE near the settlement of Ano Sagri. This Doric temple is part of the

perfectly shaped marble architecture that reflects the Attic-Ionian architecture of the 5th century (Cartwright, 2013).

It is also one example in which the second floor of the cella has been eliminated. This temple and its surrounding have been researched since 1976, which helped to understand the naxi buildings far better. Figure 24 (p.130)

Studying has been developed by researching and measuring single fragments from the site has informed the structure of the temple and the application of paint typical in Greek temple architecture shown in Figure 20. which have been put together like a jigsaw (A. Ohnesorg).

In the case of the temple of Demeter the structure and form differs from the classical rectangular shaped temples. However, understanding the classical language of architecture the structure and form can be reconstructed with little conjecture as presented in Figure 26 (p.133).

Figure 25 (p.133) shows the remains of the temple in 2003. It is basically a ruin of the former temple, which has been partially rebuilt today. Some of the columns appear to have been reconstituted and in other areas there also appears to be some partial reconstruction. However, how accurate these reconstructions are is questionable. The temple was originally constructed from repetitive units, but it is not clear if the fallen pieces have been put back in the same place that they were originally. Does this even matter given the reliability and predictability of the architecture?

Figure 26 is a presentation of a photorealistic image of the temple and its predicted shape, (produced by Digitale Archeologie), which has been influenced by G. Gruben and A. Ohnesorg (*Antike Welt* 33, 2002, 387ff).

Their image differentiates between the authentic parts of the building which survive and those which have been added. The cella was the enclosed part of the temple which contained the deity's statue and also supported the roof. So, an internal colonnade was used either side of the approach to the statue (like the aisles and nave in a church). Because the roof was pitched the colonnade needed to be taller than the columns of the portico, so were often in two tiers, hence the reference to avoiding the use of two tiers by having very tall columns. But how did the authors of the image work this out? The classical language of architecture predetermines the ratio of column height to column width, which varies depending on the Order. So, if the order is known from the surviving capitals and other details and a part of the column shaft still exists then the height can be established.

Similarly, the form and all the decorative features can be determined if the temple is typical. Analysing paint fragments can establish the temple decoration.

Therefore, knowing the classical language of architecture makes it relatively easy to reconstruct both Greek and Roman architecture, sometimes from a few small fragments. Clearly, there is always going to be some conjecture because the original builders may have been inconsistent or for some reason decided to modify the rules.



Figure 25: Temple of Demeter
(Tausch, 2013)

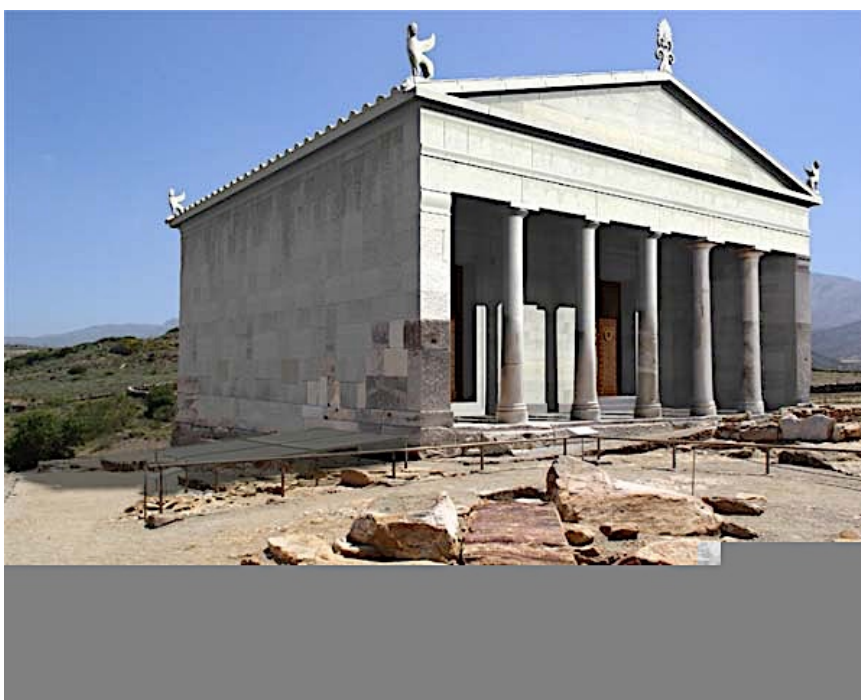

Figure 26: Photorealistic Reconstruction "Temple of Demeter"
(Matthias Link, 2014)

3.3.1.1. Summary of examples 1 & 2

The two examples shown above are virtual images of historic buildings that have been reconstructed from existing documentation based on research and physical remains. These images provide a means of further understanding the buildings and allow people to visualise their former appearance.

Virtual images such as those illustrated in the above examples are accessible by searching the internet.

These examples utilise documentation referencing the building's former appearance within their reconstruction. This type of reconstruction aims to inform the audience about the history of the building and its existence in a previous era. Both examples allow the audience to discover the history behind the building, and the virtual record supports this understanding by literally showing the audience what the building might have looked like and allowing them to consider its purpose. For conservation processes it is supportive in respect of reflecting the importance of former beliefs (such as power for example) and how over time these changes. It represents how people used to live and what they used to believe in as well as depicting the evolution of historic buildings. In both these examples, research and knowledge have allowed the former greatness or value of these buildings to be displayed meaning others can discover and examine this important history for themselves. Due to the partial loss of these buildings, the virtual image supports the conservation process in respect of managing possible future changes. By producing documentation of the building's history and reconstruction, the virtual image also illustrates the importance of maintaining historic buildings, so we know about and understand them today.

One problem with the Ishtar Gate of Babylon contravenes the Faro Convention (art. 5, 7) by removing historic parts of the building to a different environment.

The convention states that when an object is taken out of its original context, such action can cause many problems. However, archaeologists in the 19th and 20th centuries did remove cultural assets and this practice of taking assets from their original environment has caused problems for the generation of today.

According to the Faro Convention (art.5, 9) assets have to be looked after in a respectful way, as not exemplified by the Ishtar Gate of Babylon. Assets need to be cared for and protected as carefully as possible and should be displayed in a way which is appropriate to their significance.

3.3.2. Phase study of a historic building using IT-based imaging

Example 3: Hotel Engel, Engelberg, Switzerland

In order to understand historic buildings, it is important, as mentioned in Chapter 2, to first research and survey the structure and development. Phase study is a very good method to use in attempting to visualise the history of a building.

The example described below is a Hotel in Engelberg, Switzerland. In the 18th century the area became increasingly popular for tourism due to the natural beauty of environment created by the mountains. Its development has been ongoing ever since and today the village of Engelberg describes itself as a high end recreation area (AG).

In 1778, the building was extended with a new main building added onto the southwest elevation, although it appears that the roof and the upper floor were demolished. Many illustrations can be found from around this time illustrating several changes such as the previously mentioned extension. The typology constitutes a development of the “Ob- and Nidwaldnerhauses” in an enlarged and extended version to the standard for construction in 1778. In this phase, the Hotel Engel served as a monastic Inn until 1813 (former documentation of the building, research Odermatt, 2008).

The next phase of the building was around 1860 when another storey was added, and the-roof was changed. At this time the hotel developed a typical

classicist interpretation, which made it the very best hotel in the village at that time (Figure 29, p. 138) (Odermatt, 2008).

In the second half of the 19th century, around 1870, the great hall on the north side of the building was added. The hall is two storeys high. In between the older part of the hotel and the new hall on the north side another addition was realised (Figure 30, p.138).

The next phase was completed at the end of the 19th century when a balcony was added on the south side to the roof of the entrance area.

By beginning of the 20th century this balcony structure was removed and replaced by a vestibule with new balconies as the images show. The last phase took place around 1911/12 when, according to the conservation surveys, the northern hall was extended and some of the rooms were changed (Figure 31, p.138).

These different phases of Hotel Engel were created by the many changes that were made to the building over the years which have been documented by drawings, photographs and prints. However, these changes have more recently been documented by phase drawings created in CAD and illustrate the development and changes of the building in a more diagrammatic way (Figures 32-39, p. 139). The evolution of the structure over its lifetime is illustrated and by colour coding the different phases. These IT based drawings have the advantage of being easily changed and updated when further information knowledge becomes available.



Figure 27: Merian engraving 1642
source W. Odermatt

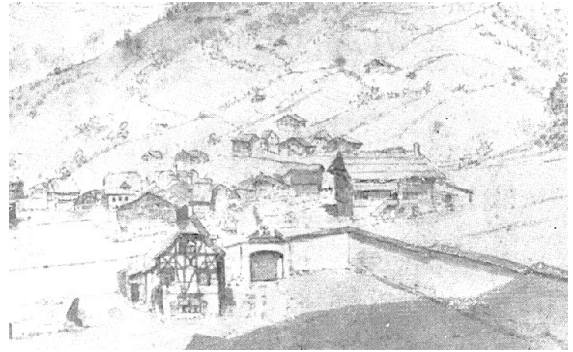

Figure 28: Watercolour painting around 1750
source W. Odermatt



Figure 29: drawing around 1860
source W. Odermatt



Figure 30: Drawing around the end of 19th century
source W. Odermatt



Figure 31: photograph around end of 19th century
Photographer unknown, source W. Odermatt

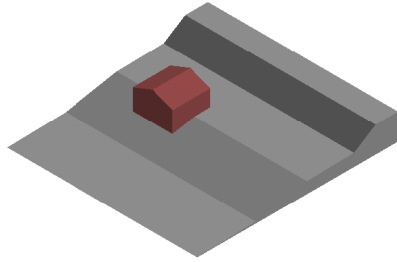

Figure 32: phase 1, CAD drawing
Done by W. Odermatt

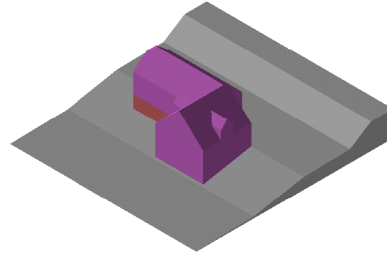

Figure 33: phase 2, CAD drawing
Done by W. Odermatt

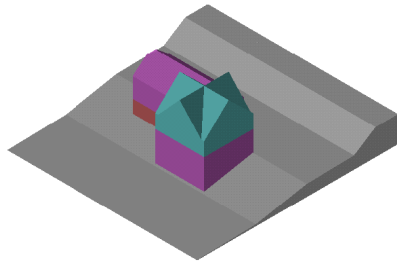

Figure 34: phase 3, CAD drawing
Done by W. Odermatt

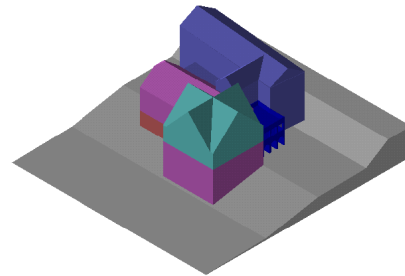

Figure 35: phase 4, CAD drawing
Done by W. Odermatt

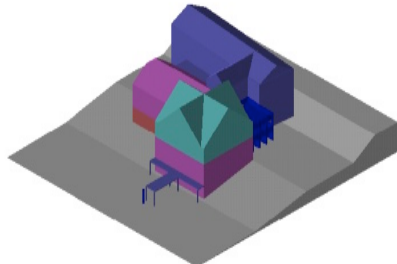

Figure 36: phase 5, CAD drawing
Done by W. Odermatt

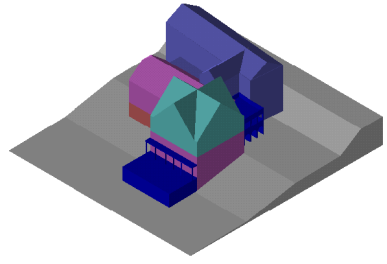

Figure 37: phase 6, CAD drawing
Done by W. Odermatt

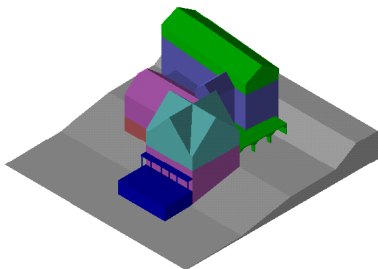

Figure 38: phase 7, CAD drawing
Done by W. Odermatt

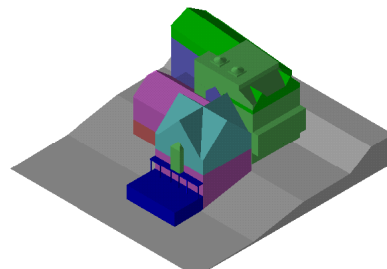

Figure 39: phase 7 minor extension, CAD drawing
Done by W. Odermatt

3.3.2.1. Summary

A phase study of a building is a very useful method to better understand a building and its changes. Dimensional surveys of the structure of the building provide the data for the drawings used for the phase study. Undertaking this activity also develops an understanding of the building's development especially by those who are already informed about the history of its construction. However, documentary research can support the identification of a building's historic phases and confirms observational knowledge. Without the latter information phased drawings are limited.

Different colours can be used in a phase study in order to identify the different periods of time, allowing a building and its structural changes to be clearly understood. However, what is missing in this type of reconstruction is the more specific details such as the building materials used and the window types.

Although this information could be provided using different types of CAD drawing techniques, such as with the reconstruction drawing of the Down House in England (Figure 40, p.141), these drawings are primarily designed to present the evolution of the building according to the analysis of the historical and archaeological surveys as part of the overall documentation related to the building. Although the Figure 40 is only partially representational as much information is omitted e.g. building materials.

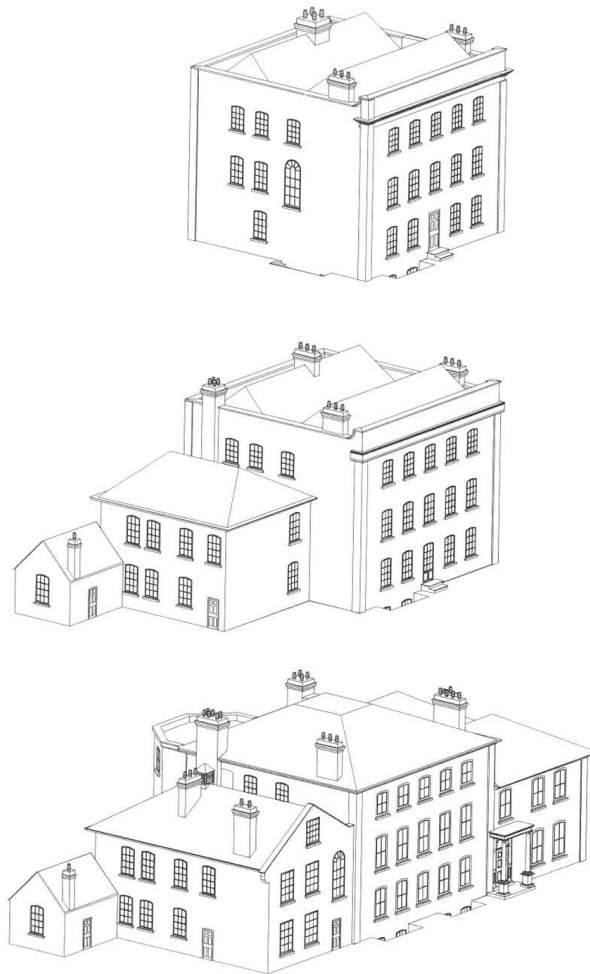

Figure 40: Down House, England, reconstruction drawing
The Presentation of Historic Building Survey in Computer Aided Draughting
(English Heritage, 2005, p. 19).

The phase study of a building supports the conservation work by enabling the development of a better understanding of the building. It is a recording method that documents the evolution of the different building phases and by using the phase drawings to illustrate these changes the conservator is able to present his or her findings to the contractor in an easily understandable visual format. It is also a good tool to discuss and agree the significance of each phase and how they should be conserved or possibly demolished.

3.3.3. Metric Survey

Example 4: The Iron Bridge at Coalbrookdale, UK



Figure 41: “The Cast Iron Bridge near Coalbrookdale”

Oil on canvas 34x40 insigned bl “W.Williams 1780”

From the collection of the “Ironbridge Gorge Museum Trust” ref. no: 1992.12918

The Iron Bridge at Coalbrookdale in the UK is a good example of the use of metric survey. Details of metric survey use have been published by English Heritage in a guidance publication titled *“Measured and Drawn”* (Andrews et al., 2009, p. 43-49). Thomas Farnolls Pritchard’s Iron Bridge at Coalbrookdale, was elected an Ancient Monument in 1934 and is part of a World Heritage Site designated by UNESCO in 1986. It is an example of the earliest major span of iron and became a prototype for iron bridge construction. It was constructed from large cast-iron parts in 1779 under the supervision of Abraham Darby III (1750-91) and Thomas Gregory (dates unknown). The dimension of the central span is 30.12m long; and is made up of five frames supporting a roadway of 42 cast deck-plates support the roadway. The span is an arch semicircle standing on stone abutments (Andrews, 2009, p. 43, 44).

A metric survey of the bridge was required after identifying major surface corrosion prior to repainting and the loss of the bearing between the deck-bearers and the deck in 1999. As part of this process drawings were prepared for the purpose of:

- Scaffolding design
- Marking up the painting regime
- Recording the repairs

(Andrews, 2009, p. 44)

The additional advantages of creating metric survey were within this project that former documentation and records such as photogrammetry (1977) and archaeological investigations did enrich this project. The metric survey data supported also producing a 3D model, which is used to inform the public. Within this project they were also able to record the repair history and to understand the structural performance and predict future failures. (Andrews, 2009, p.44-45).

The range of survey techniques that were used was as follows: TST, hand-survey techniques, laser scanning, photogrammetry, isometric sketches and narrative photography and measured drawings. This combination of techniques helped to create a 3D model of the bridge with almost no gaps. In order to better understand the bridge, it was essential for a team of specialists to work together, who had the knowledge of survey techniques and the history of the bridge and its construction. The figure below presents the plotted photogrammetry (the top image), which still shows gaps in the wire frame. With the help of TST the gaps could be closed and a complete wire frame was prepared (Figure 43, p.145).

The outcome of this project helped to animate construction sequences from the

3D model, which supported the repair of the bridge. The CAD model could also be used for assembling new pieces. The joints and fixings were established with the aid of photogrammetry (Andrews et. al., 2009, p. 48). The methods used in combination with the in-depth surveys led to the development of knowledge that two different casting processes had been used for the iron (Andrews et. al., 2009, p. 48).



Figure 42: Iron Bridge at Coalbrookdale, England

(Andrews et. al., 2009, *Measured and Drawn*, p. 43)

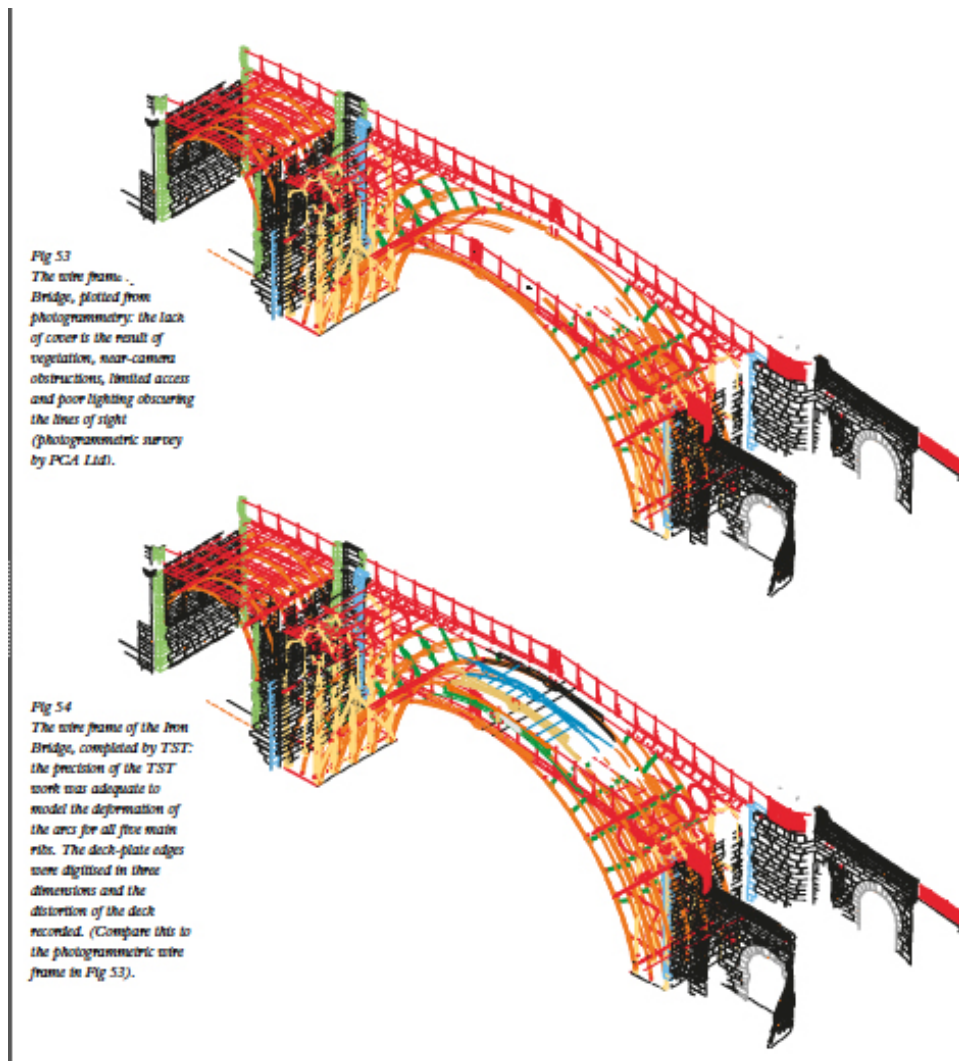

Figure 43: Iron Bridge – wire frame plotted from photogrammetry completed with TST

(Andrews et. al., 2009, *Measured and Drawn*, p. 46)

3.3.3.1. Summary

This example shows that recreating a complex structure in a virtual environment is supportive for the conservation process and the conservator. The combination of many survey techniques allowed the entire bridge to be recorded. This information was then used to reconstruct a digital model incorporating existing documentation, which was useful for more than one purpose. In the case of the Iron Bridge, it was helpful for better understanding of the necessary repairs and for recording those interventions for future

management schemes including painting, predicting and thereby possibly avoiding future failures and assisting with other future projects at the bridge.

The virtual imaging also allows visitors to experience several different viewpoints of the bridge.

Other case studies published by English Heritage in “*3D Laser Scanning for Heritage*” (2011) presented the use of laser scanning for metric surveys, too.

Benefit scanning techniques or photogrammetry is that it comprises are non-contact data collection, so the survey can be carried out from a ground level, which means that no scaffolding or only small scaffolding is needed.

The data collected has in multifunctional uses ways such as for 2D elevation drawings. (English Heritage, 2011, p. 22). However, the dataset produced by laser scanning is massive and this in itself can cause problems. Therefore, a combination of the available technologies such as scanning and photogrammetry should be considered.

The development of IT based imaging has grown and can be used to present an image with a powerful statement (e.g. , p. 153), whether the imaging is based on grounded on-site findings and research or not (see 3.1.1. When is virtual imaging appropriate?). For each conservation project there are different tools on the market to provide different results and outcomes. Deciding which scanner is appropriate depends on the task depending, for instance, whether entire facades, rooms or small objects are to be scanned. Each scanner and the associated technology come with advantages and disadvantages.

In the field of conservation, virtual reconstruction needs to be informed and verified by on-site findings, as demonstrated with the case study of the Iron

Bridge (above). Important stages in this pre-reconstruction phase include historical research, condition survey and a structural survey. If this early research does not take place the reconstruction must be described as conjectural. Sometimes interpretation may be necessary, and this should be discussed and agreed by the conservation team and declared when reconstructing cultural heritage.

The Iron Bridge is a very good example of a well-structured record of the construction of the bridge. The virtual methods used helped to understand the object, which is according to the conservation process a very important stage. This method helped the professionals involved develop a conservation and repair strategy for the bridge. And finally, the recording before the work started supported the final documentation of the bridge.

3.3.4. BIM and Semantic web technology

Example 5: Book Tower of Ghent, Belgium

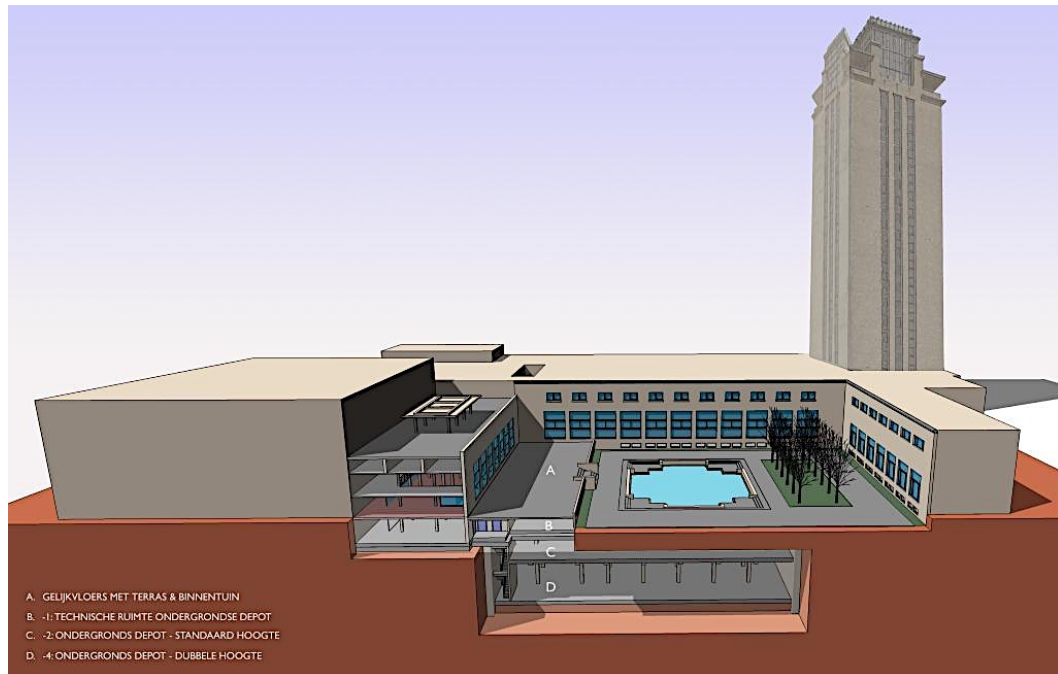

Figure 44: Book Tower, Ghent, Belgium

The Underground Repository Project University Library Ghent cc P: Pauwels #Booktower - model

“The term Building Information Modelling (BIM) is used to describe a collaborative process for the production and management of structured electronic information” (Historic England, 2017, p. 1).

BIM is a method used to describe the material and construction within a virtual model. Within this model the structure can be explored and better identified with regards to semantics.⁵¹ Semantic web technology is able to describe all the relevant information from a building. Semantic technology can be described as linked data within an enterprise.

⁵¹Definition in Glossary

The Book Tower is a project that has been developed in order to test the possibilities of BIM and semantic web technology and consider its effectiveness primarily on the documentation phase.

BIM and semantic web technologies is an attempt to analyse how far the combination of BIM technologies and semantic technologies can support the documentation of cultural heritage. (Pauwels, 2014b, p. 1), This project started several years ago, as it is a rapidly advancing technology, the acknowledgement of BIM has grown to date.

The application of BIM and semantic web technology has been applied to this case study of the Book Tower of Ghent, Belgium, to establish the effectiveness of the technology exclusively on the documentation. The first phase of the project was the documentation process, which included 1. An on-site survey, 2. A literature review, 3. Discussion with local people, 4. Existing 2D CAD drawing (These drawings were provided by the responsible university service) (Pauwels, 2014b, p. 2). The second stage of the project was the reconstruction of the building in a 3D modelling environment by using BIM software (Revit Architecture)⁵². In this environment the project team was able to use semantically rich⁵³ elements, which describe the walls for instance. This phase is supported by ontology used in the application logic of this modelling application. This phase is supported by the phase of analysis. After this the semantic enrichment phase took place, followed by integration phase. (Pauwels, 2014b, p. 3).

⁵² Software from autodesk

⁵³ data models that deliver contextually rich information, properly formatted, and targeted to provide a rich user experience (<https://blogs.sap.com/2016/08/30/the-semantically-rich-data-model-an-abap-based-cds-views-example/>)

The knowledge gained by doing this project was according to Pauwels very good, however the outcome of the reconstruction did not fulfil the accuracy that was expected. Pauwels describes that within a BIM model different information about the object, and its surroundings, can be included in the interface. The information can be gathered and linked together to allow the professionals a wider interpretation of the whole project, this is due to the assembly of more information about the object to include additional information such as its location for example (Pauwels, 2014b, p. 4 & p. 7).

The information from semantic technologies is presented as RDF/ IFC⁵⁴ graphs. Such a graph is presented in Figure 45, p. 151.

⁵⁴ Definition in Glossary

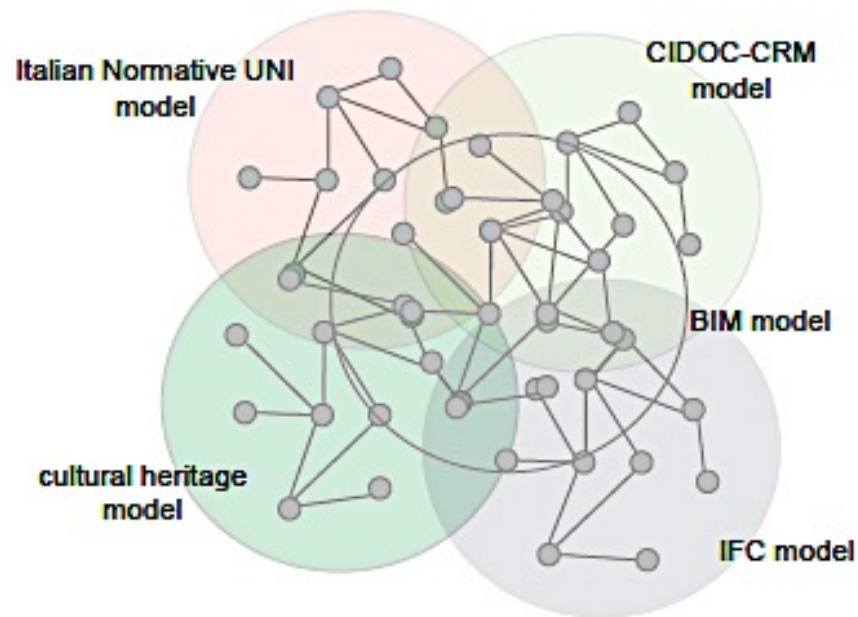

Figure 45: linkage of information

Pauwels, 2013, p. 3, Italian Normative UNI model⁵⁵ CIDOC-CRM⁵⁶

This technology assists the conservator due to the extra information available such as that concerning the building location, or the materials used. This knowledge about the building is then gathered from various different sources and brought together in one place.

This example of the Book Tower presents a way of creating a virtual model, which includes the knowledge about the building, collected firstly through the use of a survey. This project shows that documenting cultural heritage through the use of IT based technologies can be informative in a scientific way and can also be helpful for future maintenance.

⁵⁵ Definition see Glossary

⁵⁶ Definition see Glossary

3.3.4.1. Summary

Solutions such as BIM and semantic web technologies could support the documentation of cultural heritage and inform the conservation process of a building.

However, the research work on the Book Tower is part of an on-going project that has yet to be completed. Therefore, a discussion about the final outcomes is not yet possible. However, a clear structure of the working steps has been proposed and outlined within this project.

As stated under the heading 3.1.2.1, where the use of GIS and BIM were discussed, the use of a combination of different technologies can effectively support a conservation project, by allowing the professionals to gather information from several different sources and put them all in one place. The information collected through these methods can help further understand an object. Another benefit is that it provides an accurate record of the object captured at a particular moment in time, which can then be added to previous documentation and used as new information becomes available.

This method of collecting information gathered by the various professionals involved in cultural heritage may significantly help to support the conservation process. Collecting this amount of diverse data and information in one place gives a more in depth understanding of the building for all the professionals involved and allows them greater ease of collaboration. The records made by the conservators for example can be integrated into a BIM model.

3.3.5. Photogrammetry

Example 6: Great Mosque of Aleppo, Syria

This example the Great Mosque of Aleppo in Syria shows the efficiency of photogrammetry and how much detail can be documented within this technique.

It is a useful documentation tool for recording the condition of a surface.

The team of G. Fangi and P. Grüssenmeyer documented the building photogrammetrically before its destruction ((Stylianidis and Remondino, 2016), p. 50, 51). This type of documentation of a building at risk is very valuable if the decision is made to reconstruct the mosque when hostilities cease and also for research and the presentation of former cultural heritage (, p.153).



Figure 46: reconstructed minaret of the Great Mosque, Aleppo

(Stylianidis and Remondino, 2016), p.51)

3.3.5.1. Summary

Photogrammetry is less expensive than scanning and is a very accurate tool for capturing details of objects such as buildings on a much bigger scale. The data collected is a good record, which can be used for monitoring and recording the condition of the asset over time.

3.4. Conclusion

| Methods | Example | Example | Example | Example | Example | Example | Example | Advantages of Method Used | Disadvantages of Method Used |
|-----------------------------|---|---|--|--|---|--|--|--|------------------------------|
| Virtual recon- struction | Ishtar Gate / | Demeter Temple | Hotel Engel | Iron Bridge | Book Tower | Great Mosque | Supports the understanding of the object and its surrounding. It does support the hypothesis | Understood as a non scientific based image, if it has no explanation with it | |
| Photo realistic | / | / | / | / | / | / | The image is realistic and the observer does understand it as a real object | It may mislead the observer without any explanation or documentation | |
| phase study | / | / | / | / | / | / | A clear presentation of the different phases, which can tell a story of the evolution of a building, | A basic presentation of a building and its evolution without details | |
| metric survey | / | / | / | / | / | / | Supports the conservation process and aids understanding of the building. Former measuring mistakes can be corrected | It has to rely on accurate measurements | |
| BIM & semantic | / | / | / | / | / | / | Virtual reconstruction is based on clear defined puzzles, and it is enriched with information about the building | Needs to be better developed for used in the field of conservation | |
| scanning | / | / | / | / | / | / | Point cloud helps understanding of the building | Expensive and can be disturbed by pedestrians | |
| Photogrammetry | / | / | / | / | / | / | Affordable method which records surfaces | Limitation due to the material which is used. | |
| Information | historical information with a hypothetical presentation of a city gateway | historical information with a hypothetical presentation of a temple | historical information and the evolution of the building | analyses the construction, supports repairs, records the bridge for future generations | historical information about the construction, material, informs the building | Recording the moment of a cultural asset | | | |

Table 3: reflection of different techniques
K. Schütte, 2017

The examples, which have been chosen in this chapter, consider different methods of virtual reconstruction used for the recording and documentation of cultural heritage. The table above summarises these methods and describes what type of information the IT based technology may include.

The virtual presentation of historically significant buildings has been explored within the first two examples. These reconstructions are a form of documentation, which allow a greater understanding and interpretation of the former buildings. Within these two examples the reconstruction also provides educational aspects such as offering different sized models and structures which can be explored by none experts in the context of a museum or exhibition.

With the example of Hotel Engel the conservator involved in the project used a phase study to give an idea about the development of the building. This example presents the evolution of the building in a very straightforward diagrammatic way. This style of presentation of the different phases of the building supports both the conservation and planning process.

The example of the Book Tower of Ghent in Belgium, which used BIM and the semantic technology, illustrates which information a virtual model can successfully include. This project also shows how the use of a combination of different technologies can effectively support a conservation project and allows a deeper understanding of its development.

The market in the field of computer technologies is huge. Understanding the technology, which could be useful for recording and understanding heritage, can be difficult for conservation professional who are often not computer specialists. Fortunately, institutions and organisations such as Historic England and CIPA for instance have published guidance online and in books, which explain the tools, which may be helpful for recording cultural heritage. Conservation specialists need to determine the intended outcome of the recording and documentation before experts can be commissioned to assist with the implementation of IT based technologies. In Chapter 2 the author pointed out how important a structured conservation process is for conservation work. The project budget is a big issue in conservation therefore proposing a record with the aid of IT based technologies of buildings or sites must represent good value for money.

This chapter uses different examples of what can be achieved in terms of virtual image production through the use of IT based technologies. However, it is important to note that good previous documentation of the object needs to be available in order for the conservation team to successfully utilise these techniques, otherwise the virtual image is simply a work of conjecture.

CHAPTER 4 – case studies

4. Introduction

Romanesque portal at St. Kastulus Münster of Moosburg an der Isar, and a part of the Aachener Dom, are two German case studies. The following two case studies have been chosen in order to analysis the research hypothesis and address the research hypothesis in more detail.

Chapter 2 analyses discussed and analysed conservation work with reference to documentation and recording methods at the different stages of conservation work. The table. Table 1 (p. 86) has been developed specifically to highlight illustrate how virtual imaging can be used as a documentation and recording methods can support method within the professional team at different stages process of a conservation process project. This table is used for each stage of with reference to the following two case studies to explore the use of virtual imaging in more detail in order to give each stage a possible working step.

The conservation process in both Great Britain and Germany, which was discussed in depth in Chapter 2 (p. 65 and to support p. 72) compares Great Britain and Germany and further supports the analysis of the work processes.

The comparison of these two countries conservation processes was regarding made possible through the available literature particularly the publications from Historic England. The German processes are not as clearly outlined in tables or the available literature, but the knowledge gathered in Chapter 2 about the conservation processes still supports the analysis of the two case studies.

Chapter 3 compared the different technologies used for imaging in particular for cultural heritage. Table 3 (p. 86) compares the discussed techniques, but also

outlines which can be achieved. The details of understanding computer-based imaging as discussed in Chapter 3 (p. 90 onwards) allows the analysis of the documentation and recording outcomes of the techniques used within the following two case studies.

The focus within this chapter is on documentation and recording, which has been by analysing a Romanesque portal at St. Kastulus Münster of Moosburg an der Isar, and a part of the Aachener Dom, Germany.

The first case study was chosen due to the personal involvement of the author in the conservation process, which has resulted in a good working knowledge of the associated issues regarding its documentation and recording. This project involved a condition survey prior to the conservation work starting, which was carried out by several conservators (including the author). Later in the project another contract was agreed in order to monitor the site through the use of different scanning technologies. A team from the University of Bamberg, Germany undertook this additional work. As part of the future planning of the building the diocese of Munich and Freising was also interested in creation of a virtual reconstruction of a painted phase of the arch. This was the deciding factor in selecting this project as a case study for this research.

The second case study was chosen due to its excellent accessibility and the fact that it was the very first inscribed UNESCO World Heritage Site in Germany, meaning that it is a significant building of high interest within the field of cultural heritage. Due to the status and international interest in this project it has been studied in detail by various different professionals, meaning that the documentation and research work relating to its conservation has been carried

out in depth using current techniques. For instance is the dome virtually reconstructed by Dr. Sebastian Ristow and his team.

The work, that has been carried out on these two case studies is firmly based on the internationally recognised conservation process using conservation management plans as described in Chapter 2 (p.41). Both buildings have been documented using IT based technologies, which allows for a discussion about the different usage and potential outcomes of virtual imaging. The advantages and disadvantages of virtual imaging in terms of the actual conservation work undertaken will also be explored in order to explain the precise role of the conservators in this technique.

Both case studies are based in Germany, which may mean that some of the issues discussed differ ethically from those of similar projects that have been carried out in other countries in Europe. The specific differences between the conservation processes and plans within the field of cultural heritage in Germany and Great Britain, was explored in detail in Chapter 2. The outcome of this comparison highlighted that the conservation work is sometimes not as structured in Germany as it is in the UK and this is, in part, due to the lack of detail in the conservation management plan in the German projects. This makes reviewing specific phases of the work and identifying where documentation and recording has been useful difficult.

Both case studies are designated as part of Germany's cultural heritage, therefore their value and significance has been formally recognised.

As already stated earlier in the research, the conservation of cultural heritage in Germany is based upon the Charter of Venice 1964 (Chapter 2, section 2.5). In 1975, a general law for the protection of cultural heritage was introduced in Germany. Due to federalist policy, each of the total 16 individual counties, issued its own guidelines.

In Great Britain, institutions such as English Heritage, Historic England and Historic Scotland observe in their own projects and recommend through their publications the need for a structured conservation process, which leads to the development of a conservation management plan (Chapter 2). This has influenced other property owning and grant giving organisations. In Germany, such well-structured conservation management plans do not exist, because it is up to each county to decide how to deal with its historic property, the issues associated with this were explored in more detail in Chapter 2.

In the first case study the diocese of Munich and Freising and the Bavarian building authorities in the body of “Bayerisches Landesdenkmalamt” (Monument Office of Bavaria) are responsible for the property of St. Kastulus Münster.

Therefore, the guidelines of the Bavarian monument office and the diocese of Munich and Freising, must be adopted for the work in Moosburg a. d. Isar.

(More detail in Appendix 6)

For the second case study, Aachen Dom, which is based in Nordrhein-Westfalen, a different approach is followed because it is a World Heritage Site, meaning UNESCO guidelines have to be adopted (whc.unesco.org, 2012).

For the purpose of this research, a conservation management plan has been outlined which points out at what stage of the planning process for a historic

monument a conservator could use imaging in order to support their work. The same question is also considered once the actual conservation work has started. Using a conservation management plan as a theoretical outline in the analysis of the case studies aims to test the practical significance and effectiveness of imaging as a form of documentation and recording in two professional conservation projects.

4.1. Case Study Method:

From the literature review a framework was developed which maps the actions in the conservation process against the different recording methods and highlights the particular role of virtual imaging in both. The role of images, documentation and drawings are also analysed according to which specialist in the process produced or used such documentation. The study was undertaken in six single stages that map the conservation process. Table 4 illustrates the framework and is showing the single stages. These stages have been discussed in detail in Chapter 2 p.79.

| Stage | Historic Building - Actions | Recording Methods | Action carried out by | Imaging |
|-------|---|----------------------|--------------------------|---------|
| 1.A | Capturing information about the object/ building/ place (Data collection) | | | |
| 1B | Interpretation and presentation of collected data | | | |
| 2. | Analysis | | | |
| 3. | Diagnosis | | | |
| 4. | Action plan | | | |
| 5. | Conservation Work | | | |
| 6. | Documentation | | | |

Table 4: Case Study framework

Stage 1: Capturing information about the object

In this stage information was gathered in order to understand the conservation objects' location in the building and its wider surroundings, in order to support the development of an understanding about the different material or structural changes over time. This includes accessing historical information about the

conservation objects existing documentation (Hildebrandt, 2005) to include documents with images (historic images) and written words.

Stage 2: Analysis

This stage looks at the analysis of the building by surveying it in terms of the condition of the building.

Stage 3/ 4: Diagnosis/ action plan

Stage 3 outlines the process of gathering and compiling records and outlining the conservation work in the form of one compilation document. Stage 4 includes a study of how all the information from stage 2 and 3 were collected and collated and how this led to a precise action plan to be completed by the architect.

Stage 5: Conservation work

This stage covers how the conservation work is recorded. This includes the production of detailed documentation of the works that includes photographic records and a detailed mapping of any repairs undertaken.

Stage 6: Documentation

The final stage is the gathering of the full documentation into a package.

4.1.1. Specialists in the conservation process

In the conservation process a range of different specialists is involved including:

- Conservator, - Building Surveyor, - Architect, - Architecture/Art Historian, -
Archaeologists, - Monument officer.

Each of these uses documentation such as drawings, conservation guidelines, photos and virtual imaging in a different way. Therefore, the materials used are mapped against the particular specialist and at what stage in the process this occurs.

The list (Table 5) is a general overview of the professionals and the documents they might use in projects.

| Profession | Role | Supportive Documents |
|---|---|---|
| Conservator | Researching documentation observing and interpreting existing fabric, establishing significance, Specialist survey, preparing an action plan, recording the conservation work, conservation work. | Historic images, historic reports, historic and actual ground- and elevation plans, up to date images |
| Building surveyor | Dimensional/ metric survey, condition survey | Survey drawings |
| Architect | Overall project management | Conservation management plan, all the documents produced by the specialists as Conservator, Surveyors, etc. |
| Architecture/ Art Historian; Archaeologist | Researching documentation observing and interpreting existing fabric, establishing significance | Historic images, historic reports, historic plans |
| Monument officer | Ensuring compliance with legislation, giving advice | Available documents and images collected and created by all professionals involved. |

Table 5: list of professionals and their role

K. Schütte (2018)

4.1.2. The Case Study Buildings

The first case study focuses on a Romanesque portal at St. Kastulus Münster of Moosburg an der Isar, Germany (Figure 47, p.168). This project involved a condition survey prior to the conservation work starting, which was carried out by conservators (including the author). Later in the project another contract was agreed in order to monitor the site through the use of different scanning technologies. This additional work was undertaken by a team from the University of Bamberg, Germany. As part of the future planning of the building the diocese of Erzdiözese Munich and Freising were also interested in creating a virtual reconstruction of an earlier painted phase of the arch (Figure 48, p. 169). This was the deciding factor in selecting this project as a case study for this research.



Figure 47: Photography of the portal

Photography taken after the cleaning in 2010 for conservator's documentation-Planungsbüro S. Herkner



Figure 48: virtual imaging of the colour scheme

Created for Diocese München/ Freising under the instruction of Planungsbüro S. Herkner, 2011

Role of the author: This was chosen due to personal involvement of the author in the conservation process and a good working knowledge of the associated issues regarding its documentation and recording.

The second case study that will be discussed in relation to documentation and recording of cultural heritage is a project that focused on the conservation of part of Aachener Dom, Aachen, Germany. This asset was chosen due to its excellent accessibility and the fact that it was the very first UNESCO World Heritage Site in Germany, meaning that it is a significant building of high interest within the field of cultural heritage. Due to the international interest in this project it has been studied in detail by various different professionals, meaning that the documentation and research work relating to its conservation has been carried out in depth and should be well founded.

Figure 49 and Figure 50 (p. 171 & 172) illustrate a traditional hand drawing compared to a drawing based on photogrammetry. Both figures are examples from Aachener Cathedral.

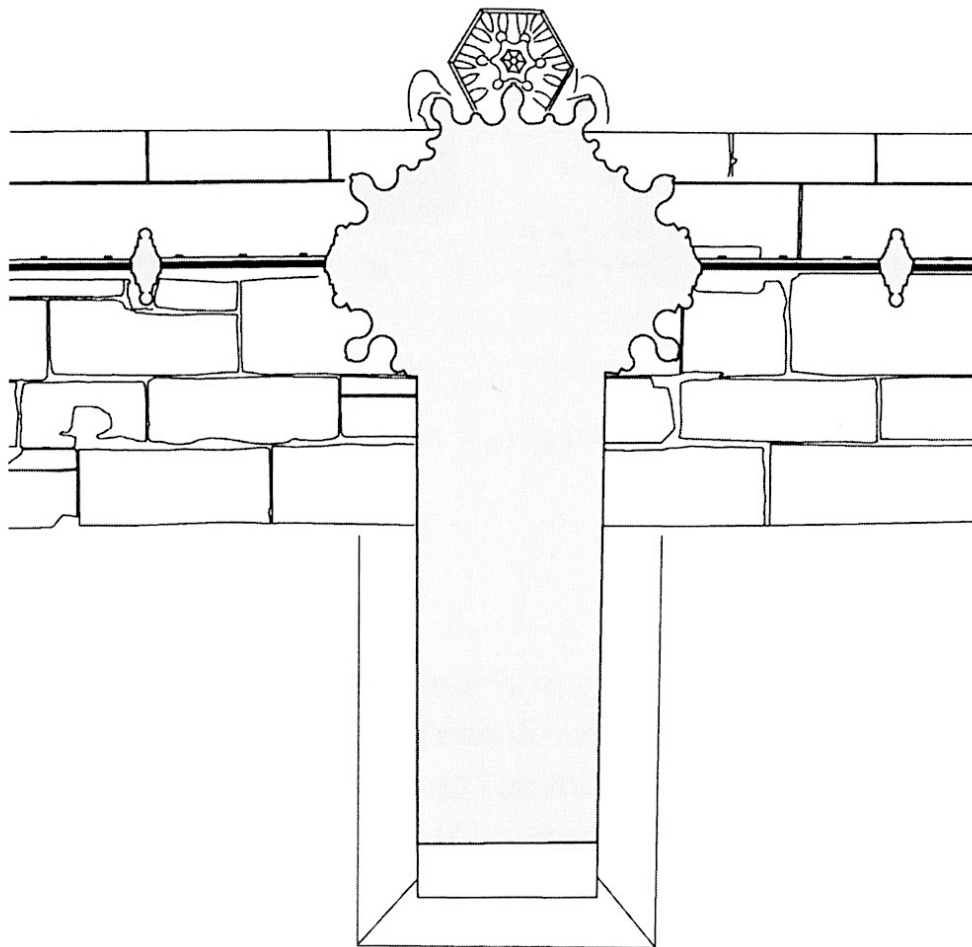

Figure 50: Pillar plan, drawing based on photogrammetry

Drawing: H.D.Heckes, Photogrammetry: Bildmessung GmbH
(LVR, 2002, p. 140)

Role of the author: The author was not involved in the second case study; however, this is a very good example due to accessibility of thorough in depth documentation of the work. The author also had the opportunity to get information from Dr. S. Ristow regarding the virtual imaging of the northern basilica, which has been reason for analysing. (see Figure 2, p. 13).

The work, that has been carried out in these two examples is firmly based on the internationally agreed conservation process using conservation management plans that were described in Chapter 2, p.

65 onwards. Both buildings have been documented by IT based technologies, which allows a discussion about the different usage and outcomes for virtual imaging. The advantages and disadvantages of virtual imaging in terms of the actual conservation work undertaken will also be closely explored to explain the role of the conservators.

Location of the Case Studies:

Both case studies are based in Germany, which may mean that some of the issues discussed differ ethically from those of similar projects that have been carried out in other countries in Europe. The specific differences between the conservation processes and plans within the field of cultural heritage in Germany and Great Britain, has already been explored in detail in Chapter 2, p.74. The outcome of this comparison highlighted that the actual conservation work is sometimes not as structured in Germany as it is in the UK and this is in part due to the lack of detail in the conservation management plan. This makes reviewing specific phases of the work and identifying where documentation and recording has been useful, difficult. Although not in these two case studies as they both use conservation management plans.

4.1.3. Summary

Both case studies are designated historic building, therefore their value and significance in the context of cultural heritage has been formally recognised.

These two buildings allow the author to explore the complexity of conservation work, the meaning of documentation in terms of cultural heritage and to consider the issues around the role of virtual imaging in building conservation.

4.2. Case study 1 – St. Kastulus Münster, Moosburg a.d.Isar, Germany

4.2.1. Stage 1 – capturing information about the object

| Stage | Historic Building - Actions | Recording Methods | Action carried out by | Imaging |
|-------|--|--|----------------------------|---------|
| 1.A | Collecting, collating and researching information about the church and its surroundings in addition to more detailed information on the portal | Initial Surveying of building; Research of documentary evidence, including historic pictures, photographs, etc. | Conservator | Yes |
| | | | Building Surveyor | Yes |
| | | | Architect | Yes |
| | | | Architecture/Art Historian | Yes |
| | | | Archaeologists | Yes |
| | | | Monument officer | Yes |
| 1B | Interpretation and presentation of collected data | Analysing the records – compilation of Historic and Architectural Evaluation Reports | Conservator | Yes |
| | | | Architect | Yes |
| | | | Building Surveyor | Yes |
| | | | Architecture/Art Historian | Yes |
| | | | Building Surveyor | Yes |

Table 6: The Role of imaging in Stage 1
(K. Schütte, p. 86)

This project focused upon the repair of a portal, which was the main entrance to the Münster of St. Kastulus. Therefore, the first stage of the project focused upon understanding the history of the church and its' context. The developmental phasing could then be identified in assist in the establishment of significance of the building and in particular the portal. Knowing about the portal's location in the building and its wider surroundings could support the conservator in understanding the process of decay due to weathering and use, or the impact of fire or other human influences from the past. A close investigation of the portal, especially from a historic perspective, and a comparison of this with its condition today, leads to an understanding of the changes made to the portal over time. Identifying historic documentation to

allow the comparison of images, architects' plans and historic descriptions of the object as briefly outlined in Chapter 1, supports the development of an understanding of the portal's phasing including the addition of different material or structural changes. This comparison could also inform the conservation work when combined with condition survey description.

Location of Moosburg a.d. Isar:

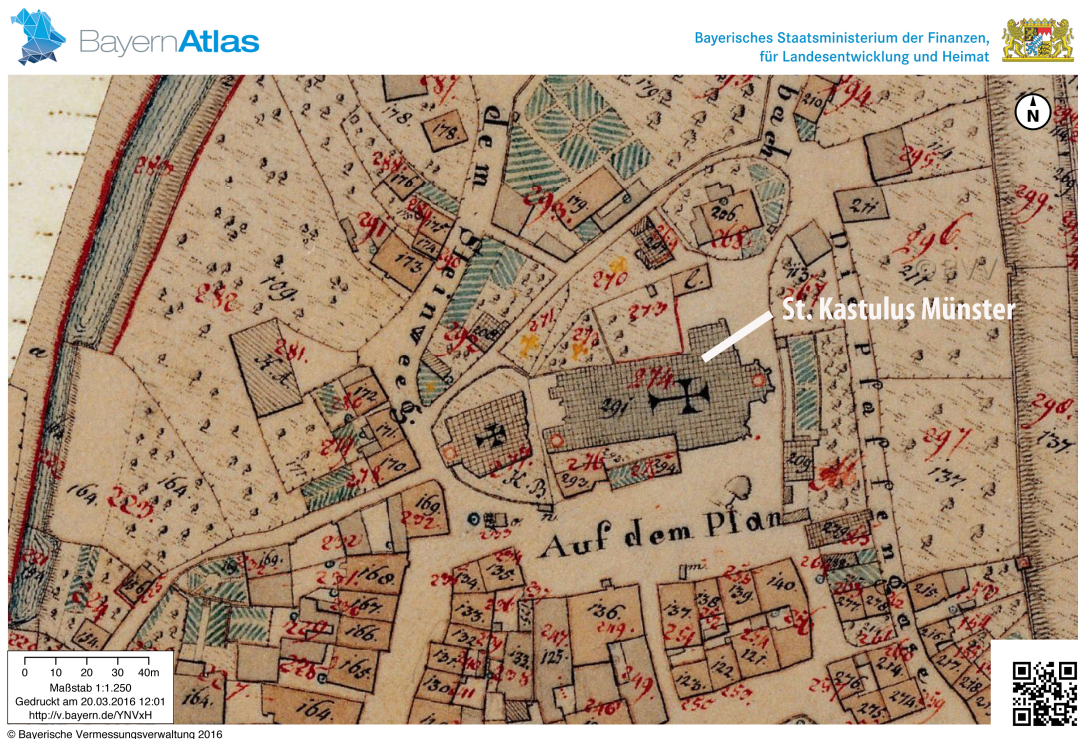

Figure 51: central Moosburg (1817-1841)
(VERMESSUNGSDATEN, B. 2016)

The starting point for Stage 1 of this project was to understand the location of the Münster. Moosburg an der Isar, which is the oldest city in Oberbayerischen county of Freising and is about 45 km northeast of Munich. The city is situated between two rivers called Isar and Amper. Locating historic documents can explain the history of the site. This work is carried out by Art Historians. Figure 51 (p. 175) is a historic map (1817-1841), which shows the centre of the town of Moosburg. The location of the church is shown in the centre of the map, marked with a cross.

Due to the location of Moosburg a.d. Isar, in between two rivers, it was concluded by the conservators' team (including scientist) that the building

materials used for the church were not necessarily local, as it would have been easy to import materials from other areas via boat. This assumption about the likely origin of the building stones was finally supported by a geological analysis. Knowing where the stones originally came from helps the conservator to understand the material better, which supports the conservation work in respect of choosing appropriate repair material.

Figure 52 (p. 177) shows a drawing of the portal of St. Kastulus Münster dated 1160-1170 and on the left-hand side is St. Kastulus Münster depicted from the west side. On the top of the drawing in the centre is Freisinger Cathedral, and in the right-hand corner is the chapel in Freising. On the right-hand side St. Peter's Church, Straubing is illustrated.

Figure 52 (one example of a known historic image) shows one phase (date unknown) in the history of the portal and its location on the west elevation of the church. Other churches situated close by are illustrated in the image

Figure 52, p. 177) and help us to understand the past importance of the portal due to its relationship to other churches in the region. This importance is a criterion for evaluating the value and significance of this specific object. This image outlines, at least partially, how the Catholic Church influenced this specific area due to its presence.

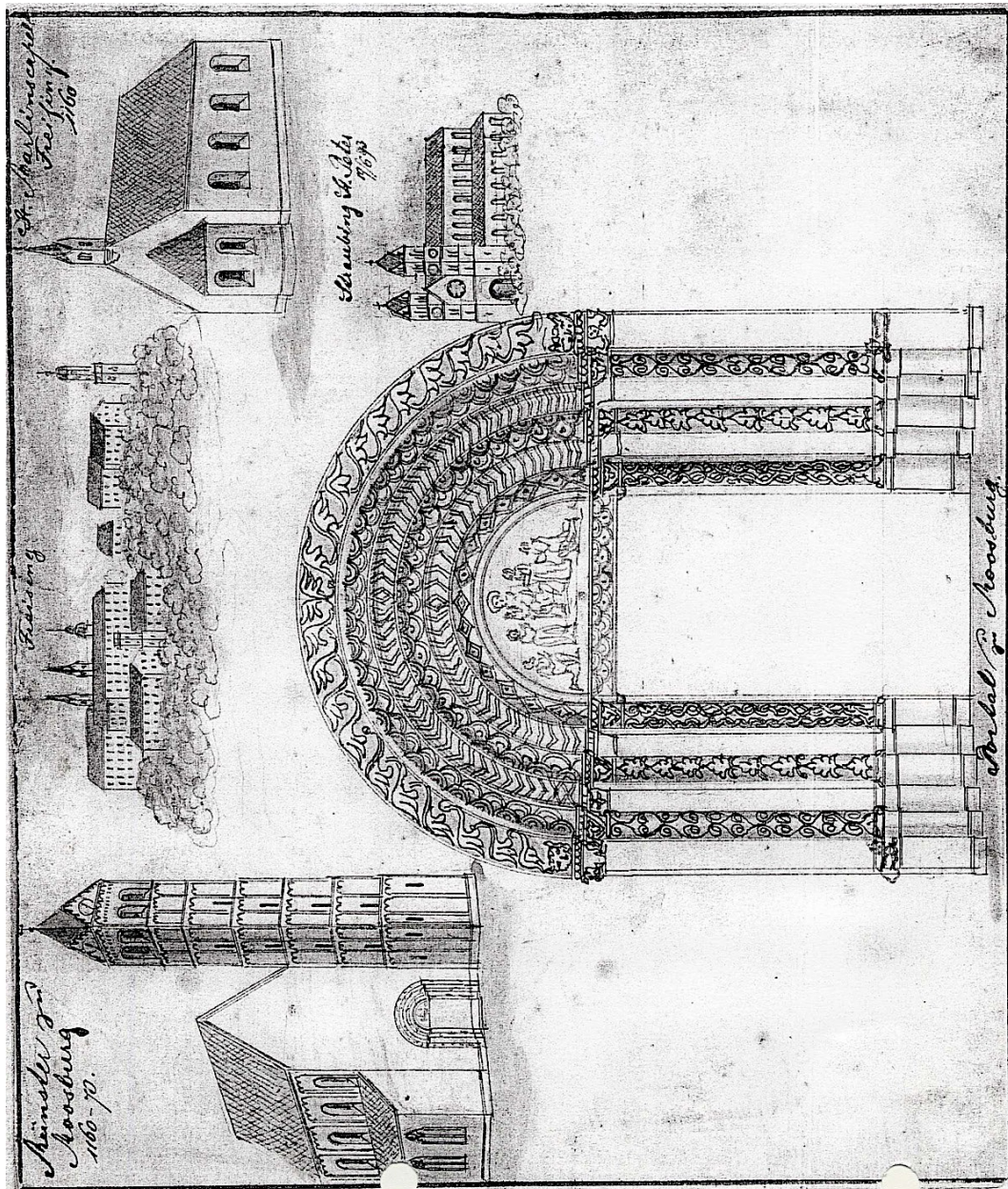

Figure 52: Hand drawing

Which shows the portal before dismantling the lobby (Date unknown) (Hildebrandt, 2005)

Description of the portal

The portal at the west side of the church, which is the main area of interest for this research, is a Romanesque portal, which was built after a huge fire around 1159. It is a projecting semi-circular portal of repetitive stepped jambs containing ornamented columns supporting concentric half round arches, in the typical Romanesque style (the period in England often called England Norman) (Erzbistum-Muenchen, 2013).

On the top of each side pier, two stone lions symbolically guard the entrance and are therefore called the guardians. The portal is divided into two main sections; the upper one with the concentric arches which inscribes a tympanum containing sculpture in the spandrel, and the lower section including the columns and piers together with the entrance door with a decorative lintel.

The embedded circular columns are decorated with textile-like patterns. These carvings symbolize or depict straw, chains and a zigzag (chevron) pattern. This is again typical of the Romanesque period. The base of each column is fluted and the capitals are half cushion. The left capital is decorated with a leaf pattern and the right with a bow pattern. The rectangular piers situated at the front corners, have relieved capitals that depict dancers and musicians (Figure 53, p. 179).

The tympanum itself shows a scene with Christ and two Saints, which is described in more detail in the appendix 7. The portal has been built in stone.

The columns are green sandstone, and the tympanum and the arches are built in malm limestone. The decorative parts are carved stone. The walls around the portal are masonry, which has been plastered with a lime plaster. The materials have been identified through surveying and in particular by laboratory analysis.



Figure 53: Overview of the Romanesque Portal To St. kastulus 1900/ 1940

Fotoarchiv Marburg, photograph taken around 1900/ 1940 Romanesque portal to St. Kastulus taken between 1900 and 1940



Figure 54: Detail Lions and Capitals

Detailed photograph of the rectangular pillar and columns on the left-hand side of the portal 1900 to 1940, Marburger Fotoarchiv

Conservation history

In the archival research undertaken first by Hildebrandt (art historian) (2005) and later adopted by Herkner (conservator) (2008), instructions were found on the products that were used in 1972, which could be responsible for the hydrophobic properties of the rock surfaces. The conservation history of this building is described in more detail in Appendix 7.

Therefore, the first stage of the process of conserving the portal has been informed by the existing documentation (Hildebrandt, 2005), which included historic images, and written report prepared by Hildebrandt. As described in Chapter 2, this process of gathering knowledge is a very important methodology in order to properly understand the building.

This documentation informed the recent analysis of the fabric of the portal by the scientist by helping to build a better understanding of how it had decayed in the past, for example, the weathering of the hydrophobic stone surfaces. The scientist, who analysed the stone types, their origin and the decay, was also informed by this documentary knowledge gathered beforehand. This demonstrates how important past knowledge is in planning the care of the buildings today.

4.2.2. Stage 2 - analysis

| Stage | Historic Building - Actions | Recording Methods | Action carried out by | Imaging |
|-------|-----------------------------|---|--|---------|
| 2. | Analysis | Analysing the building by surveying in terms of the condition of the building | Conservator/ Archaeologist/ Architect | Yes |

Table 7: The Role of imaging in Stage 2
(K. Schütte, p. 86)

Stage 2 of the conservation process took the form of a condition survey which the diocese Moosburg/ Freising agreed to and which was carried out directly on site by a conservation team. The architect produced a hand drawing of the portal. The conservators first observed the surface of the portal and mapping the decay. The condition survey was mapped onto a paper print of a digital photograph of the portal, which was taken before the scaffolding was erected. The condition survey was then digitised in the office with AutoCAD software. The digital mapping supports the analysis of the decayed areas including outlining the size and scale. For future maintenance work this mapping can be reused and possible decaying process can be analysed for example overlaying images and re-mapping the decayed areas.

Figure 55 (p.57) shows an example mapping which was carried out to identify specific decay.



Figure 55: Mapping of the Portal

Has been undertaken by K. Schütte for Dipl. Rest. S. Herkner 2010

Legend:

Yellow areas = Defective plaster

Blue and Pink areas = Damaged stonework

After the condition survey was completed a laboratory analysis of the decay took place (done by scientist Dr. E. Wendler). First of all, the different rock types were identified: - Malm limestone, - Glaukonitischer green sandstone ("*Regensburger*" chalk), - Reddish quartz sandstone (Wendler, 2008), and the plastered masonry above the portal.

Subsequently, the damage was described in the condition report in more detail: A significant type of damage on the Portal is caused by weathering of "Malm" limestone. This includes shell loss, efflorescence of rock components and damage to rock components as a result of active processes such as granular degeneration in the form of dusting, flaking and shattering. Numerous types of pollution are also causing sulphation crusts, in addition to bird droppings, biological growth, etc. especially in the ornamented area such as the tympanum, where there was a serious decay problem.

During the survey of the portal (Stage 2) the remaining particles of paint fragments that were discovered allowed the conservators to identify the original, historic colour scheme. An exclusive hand drawn mapping of the remaining pigments was prepared by the conservator S. Herkner. For the precise classification of the paint layers a close analysis of the painted surface was carried out. For that analysis, thin sections of paint flakes were produced and then when these flakes were studied under the microscopy two layers of paint were discovered. This analysis was carried out by a professional laboratory in Bamberg, Germany. Following the laboratory analysis, the conclusion was that the polychrome painted tympanum had been repainted at least twice in its past and the paint had been applied onto the stonework itself without any plaster layers underneath. Figure 56 (p. 192) shows a fragment of a painted surface on

stone and Figure 61 (p. 192) shows a cross section of a paint flake under the microscope. Figure 62 (p. 193), the untrained eye would not have discovered the colours and therefore would possibly recognise the portal as plain unpainted stonework. Figure 58 (p. 193) the red, blue and yellow coloured areas indicate where in the condition survey the remains of the paint flakes were on the portal. The mapping (Figure 58, p. 193) helped to argue in favour of a reconstruction of the painted portal. However, a reapplication of the paintwork to physically reconstruct this 12th or 13th century colour scheme has not been considered. Instead it was suggested that the work be undertaken as a virtual reconstruction, which could then be presented within an exhibition. The condition survey was brought together in a report. This included the digitised mapping, photography's of the decayed areas and description.

4.2.3. Stage 3 & stage 4 – diagnosis/ action plan

| Stage | Historic Building - Actions | Recording Methods | Action carried out by | Imaging |
|-------|---|--|--|---------|
| 3. | Diagnosis: Agreement that Preservation was the appropriate approach for the Portal | Preparing Project drawings and specifications incorporating the recommendations of the specialists and consultants. | Architect, Conservator, Scientist, monument officer | Yes |
| 4. | Action plan: the project planning, finance, insurance and compliance with legislation including Health & Safety | Preparing the Project programme for conservation work incorporating the individual programmes of the specialists and consultants together with recognising clients' and regulatory requirements. | Architect, Conservator, Scientist, project manager, monument officer | Yes |

Table 8: The Role of imaging in Stage 3 and 4
(K. Schütte, p. 86)

With the knowledge gathered from stage 1 and 2, a conservation strategy for conservation was accomplished by recognising a set of aims in order to effectively protect and conserve the portal. The architect, the monument officer and the client, who reached the decision for the action plan, have discussed the report provided by the conservators.

Mock-ups were carried out by the conservators to test and analyse the conservation materials over a certain period of time.

They were aimed at solving the following problems:

- Strengthening the damaged paint layers. Here it is especially important to let the preservative penetrate behind the layers of paint and allow a connection of tempera paint layers to the hydrophobic limestone.
- Cleaning the rock surfaces. Different methods were tested by the conservator: mechanical removal of debris using brushes and steam; micro-particle beam

method with a separate cleaning substrate, operating pressure, nozzle size and working distance, and laser cleaning; and chemical treatments using ion exchanger, ammonium carbonate, etc.

- Poultice for reducing the salts.
- Consolidating friable stone surfaces. Preservatives should be tested that consolidate the granular dusting of limestone and the dusting and flaking of the sandstone. Also, other materials are to be tested which enable the connection of dissolved rock shells from weathered nonhydrophobised rock.
- Shelter coat of highly rugged surfaces in order that the gaps between crater-like decayed surfaces in limestone should be filled.

The conservation team developed the concept and proposed treatment, which were incorporated into the overall action plan. This agreement included the conservation philosophy, which recommended minimal treatment according to the guidelines of the Bavarian monument office (which is included in Appendix 6). Because the doorway contained by the portal was still used by the public during the entire work process the architect carried out a risk assessment before the project started on site.

The finished examination including the development of a concept regarding how to treat the surface of the portal was presented to the owners, the *Denkmalamt*, the architect and the members of the church by the conservator. The conservation team (conservator, architect for research and survey, scientist) also presented the costing to the project manager.

Imaging and written documents, which supported the decisions made in Stage 3, also supported the following stages.

Stage 4 - the action plan: Collecting and collating all the information from Stages 2 and 3 allowed a precise action plan to be completed by the architect. The first step was mapping the actions, followed by stage 2, which was an analysis of the findings. This step included the building's condition effects regulatory requirements such as Health and Safety and also Risk Assessment. The conservation team and the scientist were involved in stage 3 and 4 and put together the results of the findings. The final documentation regarding appropriate future action was presented to the monument officer and the representative of the Diocese of Munich and Freising, who agreed to the proposed action plan.

4.2.4. Stage 5 - Conservation work

| Stage | Historic Building - Actions | Recording Methods | Action carried out by | Imaging |
|-------|-----------------------------|---------------------------------|---------------------------------|---------|
| 5. | Conservation Work | Recording the conservation work | Conservator/ Crafts people etc. | Yes |

Table 9: The Role of imaging in Stage 5
(K.Schütte, p.86)

At this stage the actual work has been carried out. That included the hands on work, which has been agreed within the action plan. Throughout the entire conservation work a detailed documentation of the works was carried out to include photographic records and a detailed mapping of the repairs undertaken.

4.2.5. Stage 6 – Documentation

| Stage | Historic Building - Actions | Recording Methods | Action carried out by | Imaging |
|-------|-----------------------------|---|-----------------------|---------|
| 6. | Documentation | The Records put together in a final documentation | Conservator/ etc. | Yes |

Table 10: The Role of imaging in Stage 6
(K. Schütte, p. 86)

Documentation of the conservation work took the form of a detailed photographic record, a description of the work in words and an illustration of the decayed areas by hand drawn mappings as shown in Figure 55 (p.183). The project was successfully completed according to the conservation management plan however, Miss S. Herkner was subsequently asked to put a team together for the creation of a virtual image of this portal for a planned exhibition called: *"KULT RAUM KULTUR RAUM"* (Freising, 2011). The team for the work included:

- Otto-Friedrich-University of Bamberg, Germany, which is well equipped with scanners and technicians who produced an accurate scan of the portal for remodelling.

- A graphic designer, who made a virtual model of this portal and put the colour layers on top.
- A moviemaker, who created an augmented reality image. However, this part is not relevant for this research, because it only considers imaging in conservation and not augmented reality or similar interventions.

The scanning processes

The scan of the portal was created with a terrestrial scanner for the entire portal and its surroundings. A white light hand scanner was then used to capture the details of the surfaces. Data processing: Terrestrial scanner:

The selection of the standpoints was strongly influenced by the surroundings and possibility of pedestrians. The distinctive features of the portal and the characteristics of the equipment employed have been taken into consideration.

The aim was to get a full coverage of the portal with the terrestrial scanner and produce good superimpositions between the different scanned images, so as to be able to perform the subsequent union of the clouds through homologous points. (Galizia, 2015, p. 2).

For monitoring purposes, the scans produced by the expert team from Otto-Friedrich-University of Bamberg, were subsequently analysed. The scans showed the exact location of repairs and the precise depth of the repair mortar.

This scan is an accurate record of the conservation work at the portal.

Recording the conservation work by scanning the surface and using this data for monitoring was one purpose. The scan and the information gathered in Stage 1 also supported the creation of a virtual reconstruction. This virtual image has been produced for an exhibition with the aim of presenting a former

colour scheme. The knowledge from the research work and the analysis, which was carried out prior to the conservation work, is a crucial aspect of a reconstruction. Without any background knowledge, the colour scheme could have been interpreted wrongly and the audience perception could therefore be incorrect.

Workflow for the reconstruction

After the scan was produced the computer scientist was able to model the portal virtually with additional hand measurements and drawings. The computer scientist needed to understand the shape and form of the portal, so that he was able to produce an accurate model. The next step was to apply the paint layers to the surface. This was teamwork with the computer scientist producing the model virtually and the conservator indicating which colour needed to be where. This was difficult because the vocabulary of terms used by the computer scientist and the conservators were slightly different. It appeared that an understanding of what was meant by certain words such as “shine” for example caused some initial confusion and problems. However, the outcome of the reconstruction was satisfactory, and the exhibit was a success. Figure 59 p.194 shows a series of images of the portal from left to right as follows: the physical portal before any conservation work took place, the physical portal after the conservation work, the virtual reconstruction of the portal, and finally a detail of the virtual reconstruction of the portal. The parts, which are not coloured in the virtual reconstruction, point out the unknown areas of the colour scheme.



Figure 56: Close up of remaining paint

Photograph of a remaining painted layer in the tympanum, photo taken by S. Herkner 2006

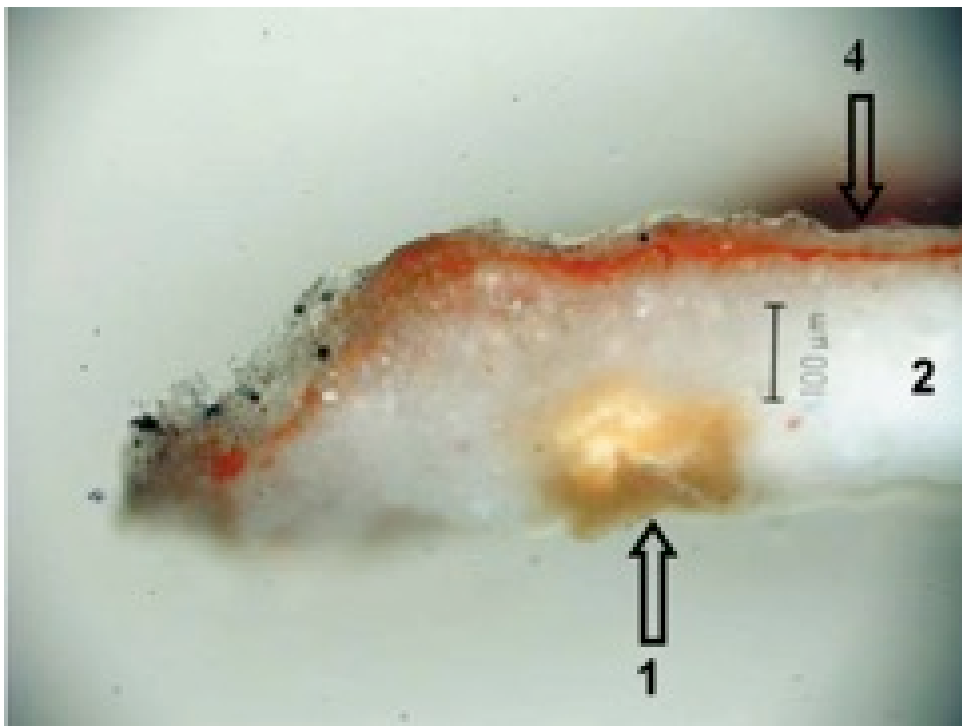

Figure 57: Cross section of paint flake

Thin section: ground layer oil glue mixture; 1 – binder cherry gum; 2 – primer chalk

4 – Two-layer binder animal glue and chalk with pigments red. by S. Herkner 2006

really helped to understand the layering of the paint. The scientific analysis was also able to identify what binder had been used for the pigments. However, it was the condition survey that drew attention to the remaining flakes.

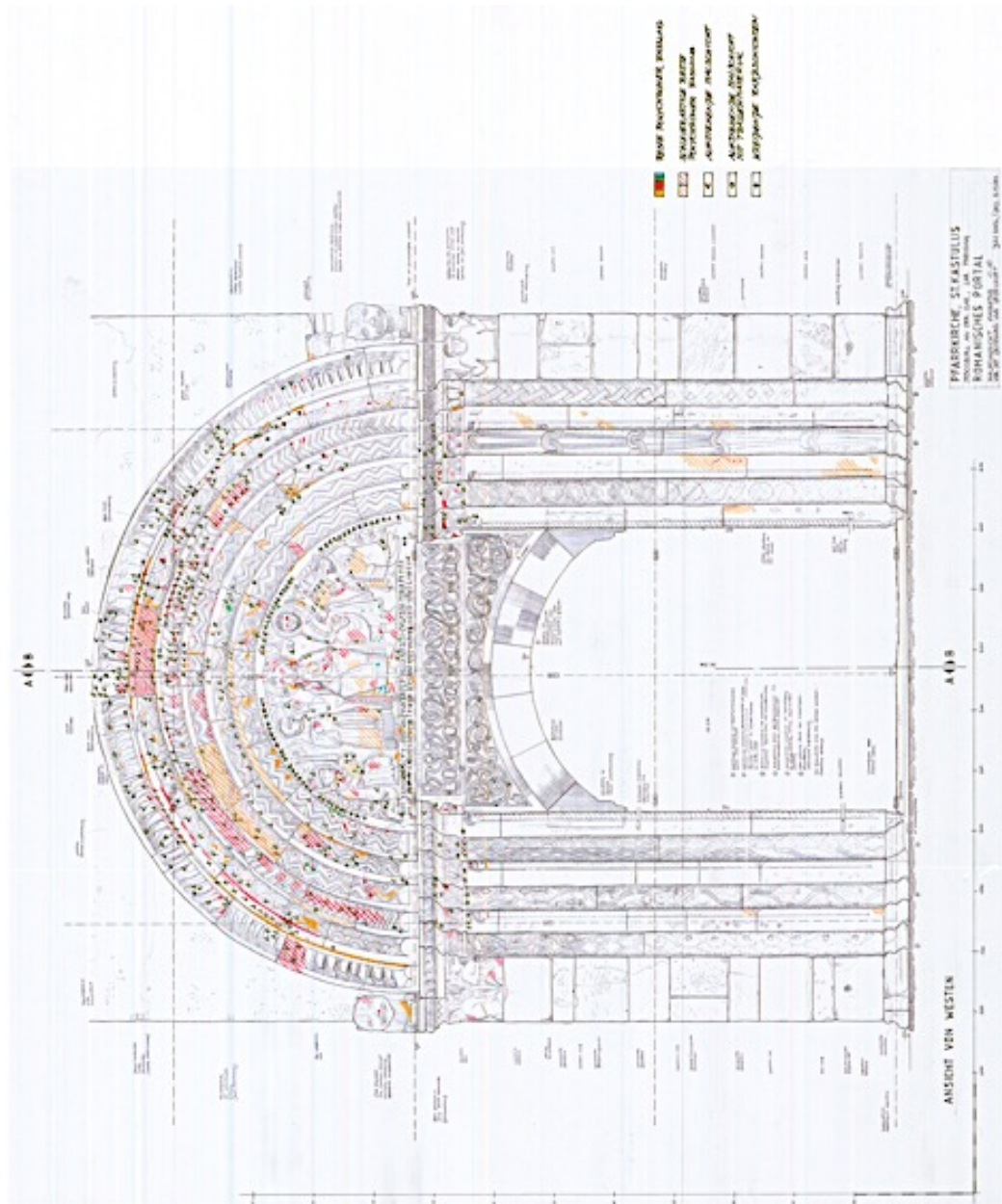

Figure 58: Mapping

The hand mapping, which has been carried out on site with pencils on a drawing of the portal, has been created by S. Herkner shows in detail the remains of different painted areas.



Figure 59: Details of the Portal

from left to right: portal before conservation, portal after conservation, virtual reconstruction with polychrome colour scheme white areas left white because of unknown colour, detail of the virtual reconstruction Kunsthistorischer Verein booklet (Freising, 2011, p. 70, 71)

4.2.6. Summary

According to the author's conservation management plan created in Chapter 2 (p.82) each step described within this case study illustrates that images are supporting the actions. When the historical aspects of the portal in Moosburg an der Isar, Germany, were being analysed and researched, the conservator as the art historian was involved, because this kind of work includes researching archives and historic documentations as analysing the findings. The knowledge from this research work was used to support the work by historical descriptions accompanied by historic images support a deeper understanding of the asset and this understanding informs the decision-making and interpretation process of the conservation work.

The professionals involved in the research and analysis stage of the conservation process were able to propose a conservation plan to the owners and the institution. With the help of scanning, in this case a terrestrial laser scanner and a white strip scanner, the repair process was monitored and documented. Repeating the monitoring process means that there is a follow up proposal in place. According to the diagram in Appendix 2, this provides a schedule of future work for the object (Corr, 2011, p. 40-43). The advantage of repeat monitoring at regular intervals after the completion of a project should reduce extensive and costly conservation work in the future. However, this means that someone has to be responsible for this monitoring and ensures it is undertaken. In the case of the portal of St. Kastulus Münster, Moosburg a.d. Isar, this has not happened yet.

The initial interest in producing a scan for monitoring purposes seemed high, but later enthusiasm for this often wains so it may be forgotten when future

maintenance work takes place. The author asked Otto-Karl University of Bamberg whether further monitoring had been carried out at the portal of St. Kastulus church in Mossburg an der Isar, however Prof. Dr. Drewello, who was in charge, has not yet responded.

The conservation philosophy, for this portal was minimal intervention. This required that the conservation work carried out at this site was to have minimal impact to achieve the aim of appearing to keep everything as it was found. The virtual reconstruction of the colour scheme did not affect the actual portal. However, it is a valid and useful documentary image and record of what the building was like in its past for future generations. This is an important record as the actual paint flakes and layers may disappear over the years and without this record the colour richness of the portal may forgotten.

The conditions for exploring virtual imaging, from the starting point of initial research to the final result, were perfect. It included a team of professionals working together including a computer scientist, art historians and even a filmmaker. However, this combination of professionals turned out to be a challenge. The different professions which were involved in the project and were needed in order to produce the virtual images, as mentioned in Chapter 2, have very different understandings of certain words and terms such as colour glazing for example. Therefore, the precise terminology of words, which are used to describe historic buildings, need to be consistent and clear for all professionals.

4.3. Case study 2 – Aachen Cathedral, Germany

Case study 2 analyses the Palatine Chapel, which is one of the oldest structures on the site of Aachen Cathedral. With this building the conservation process will be examined. Therefore, the conservation process developed in Chapter 2 and its stages are considered for the work undertaken within this chapel building. Finally, a virtual reconstruction of the northern basilica will be presented, because a virtual reconstruction of the Palatine Chapel was not available for the author.

4.3.1. Stage 1 – capturing information about the object

| Stage | Historic Building - Actions | Recording Methods | Action carried out by | Imaging |
|-------|--|--|----------------------------|---------|
| 1.A | Capturing information about the object/ building/ place (Data collection and collation) | Initial Survey of building by observation (Level 1); Recording documentary evidence, historic pictures, photographs, etc. | Conservator | Yes |
| | | | Building Surveyor | Yes |
| | | | Architect | Yes |
| | | | Architecture/Art Historian | Yes |
| | | | Archaeologists | Yes |
| | | | Monument officer | Yes |
| 1B | Interpretation of documentation and preparation of findings | Compilation of Historic and Architectural Evaluation Report | Conservator | Yes |
| | | | Architect | YES |
| | | | Building Surveyor | Yes |
| 1C | Dimensional/ metric Survey | Prsentation of measured drawings | Architect | Yes |
| | | | Building Surveyor | Yes |
| | | | Conservator | Yes |

Table 11: The Role of imaging in Stage 1 of Aachen Cathedral's Palatine Chapel's Conservation Project (K. Schütte, p. 86)

Location of the Aachen Cathedral

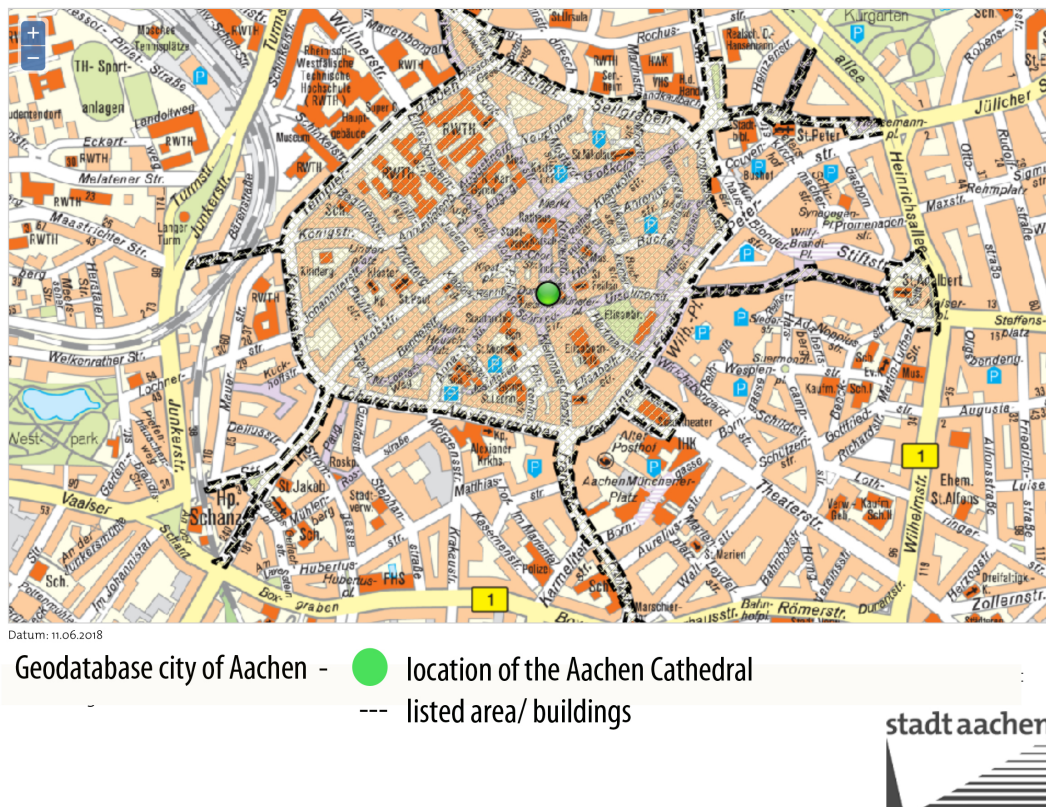

Figure 60: section of Aachen
 (Geoportal.aachen.de. n.d.)

The city of Aachen is located in Northrhine Westphalia, near the boarder with Belgium in western Germany. Today`s city centre is the oldest part of the settlement, which has been developed over time initially under the influence from Charlemagne. Figure 60 (p. 198) shows central Aachen and the location of the Cathedral marked with a green dot. The cathedral complex is made up of an ensemble of different buildings, Figure 58 (p.197). The current ground plan of the Palatine Chapel includes the extensions added during the Gothic and the Baroque to the original Carolingian structure.

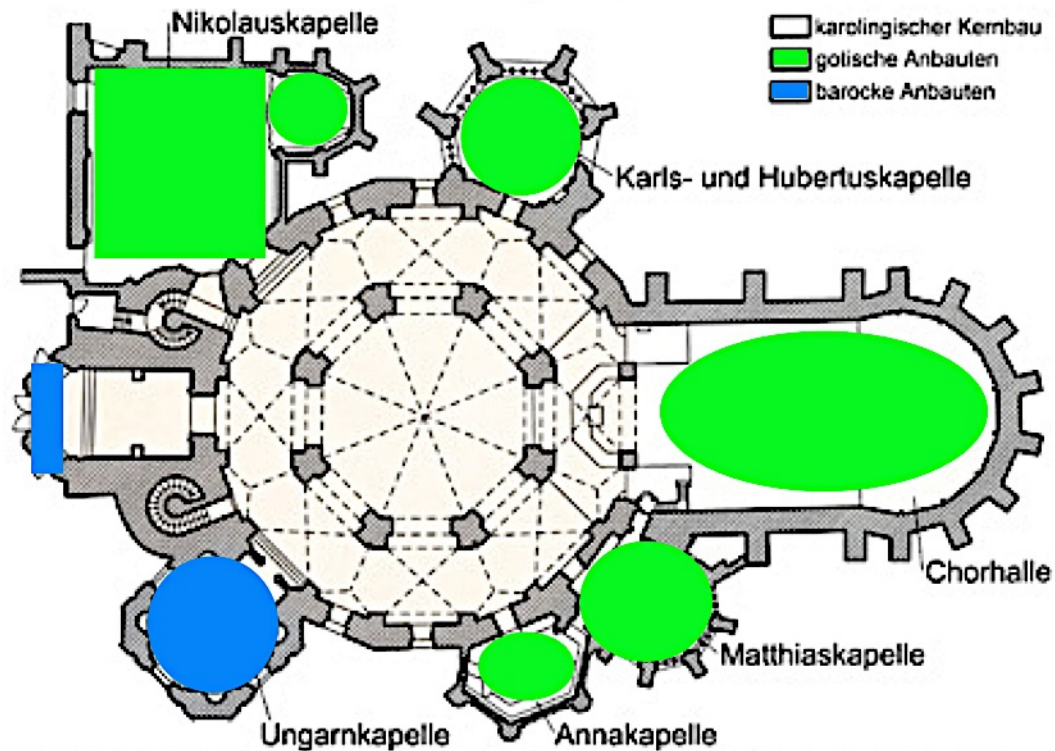

Figure 61: Palatine Chapel

Carolingian Period with the gothic (green) and baroque (blue) extensions, (LVR, 2012, p. 120)

Description

The Aachen Cathedral is a major cultural heritage site in Germany due to its long and influential history. This history is summarised briefly below:

- Palatine Chapel built between 793 – 813 AD as part of a palace by Charlemagne Emperor of the Holy Roman Empire and inspired by the churches of the Eastern part of that Empire; it symbolised unification of the West.
- In the 14th century it became an important place of pilgrimage to the north of the Alps therefore enlargement of the chapel was required, with the choir hall completed in 1414
- 14th/ 15th century side chapels were added
- 1656 a fire damaged the church
- 1802-1827 the “Münster” was raised to a Cathedral Church
- Major restoration and changes in the 19th century

- 1978 the cathedral became the first German building inscribed on the list of UNESCO World Heritage Sites.

In the UNESCO's Nomination File significance of Aachen Cathedral is described as:

"Integrity

Aachen Cathedral contains all the elements necessary to express the Outstanding Universal Value and is of appropriate size. All features and structures to convey its significance, as Emperor Charlemagne's own Palatine Chapel are present.

Authenticity

Form and design, material and substance, use and function as church and most important pilgrimage site north of the Alps have remained unchanged."
UNESCO (1992 - 2016)

The history of the "Aachen Cathedral" is unique and its construction impressive.

(A more detailed description of the building can be read in the Appendix 8).

The following ground plan in Figure 58 gives a good overview of the Cathedral complex in Aachen and includes all the different buildings named and drawn to scale.

Knowledge about the history of the building is complex and its documentation assisted in understanding the Palatine Chapel's history and possible former states. A good example of this is represented in the historic images and attitudes to decoration in the surface of external walling. According to a recent description of the Palatine Chapel, the masonry seemed to have been originally plastered and painted (LVR, 2012, p. 155). It is likely that this plaster was removed in the 19th century when the purification of historic religious buildings was common in Europe. Therefore, today's appearance is of multi coloured masonry due to the different stone types and pointing mortars that were never intended to be visible until the plaster finish was removed. Evidence of the earlier finish is seen in an oil painting from an unknown artist around 1622

which gives the impression of a bright plastered wall to the chapel (Figure 64, p. 204). Another painting by Michael Neher shows the chapel around 1853 with a greyish coloured finish, which is likely to have been after its purification (Figure 65, p. 205). The images impart an impression that the masonry might have been originally plastered. However, these images are paintings and rely on interpretation. Still these types of records do give an indication of the history and knowledge of contemporary architecture of the time helps confirm the likelihood of painted plaster finishes.

The knowledge gathered about the Aachener Cathedral by analysing the historic documents and images allows a step forward to the next stage in the process with an informed eye. However, it should be noted that according to the monument office of Rhinelandpfalz different professionals such as archaeologists and art historians for example are still investigating and researching this monument and its surroundings. Therefore stage 1 in the context of this cultural heritage is not concluded. LVR – Landesverband Rhineland.

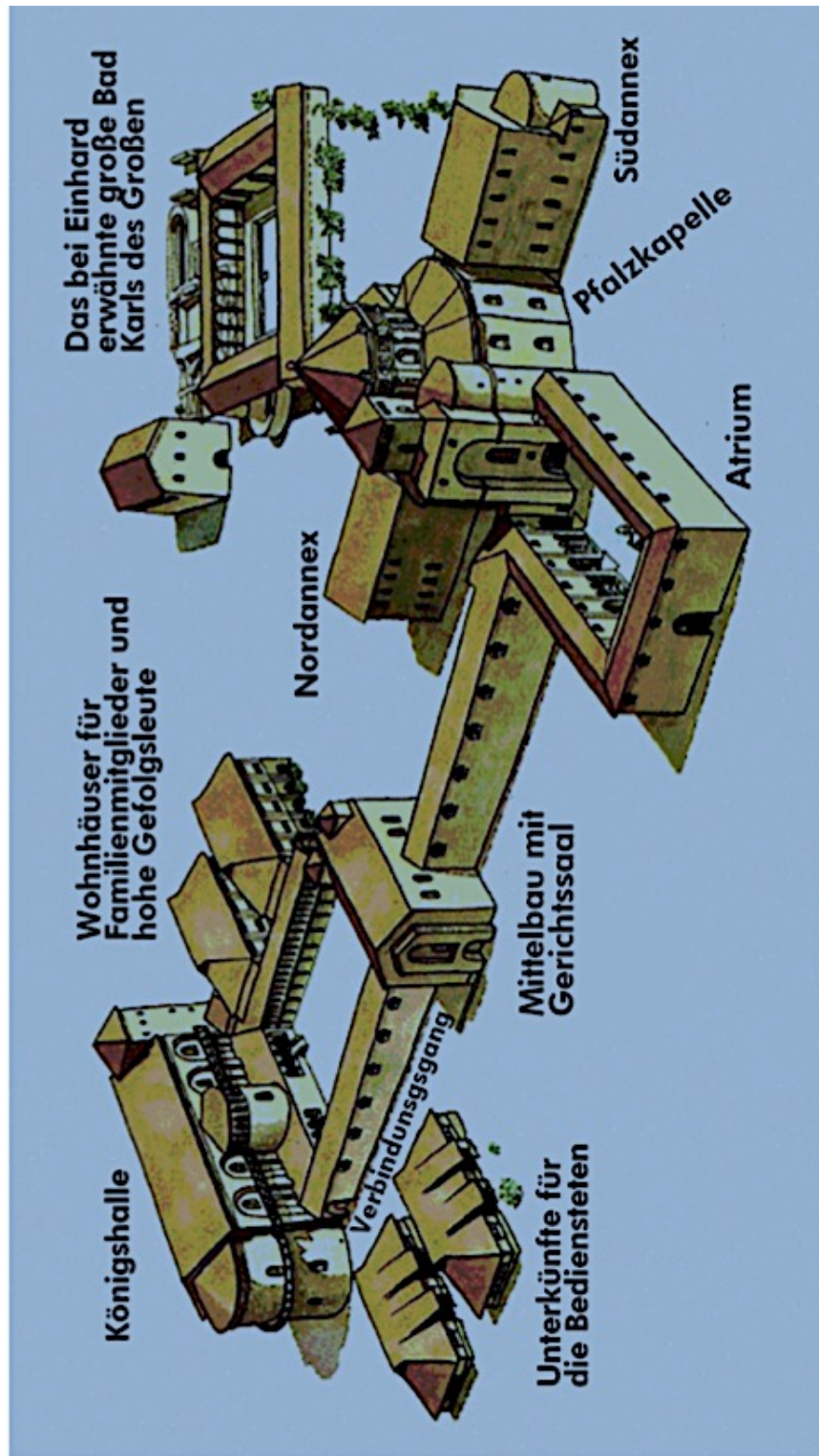

Figure 62: a hypothetical model drawing of the “Pfalzgrafanlage”

(Packbierpeter.de, n.d.)

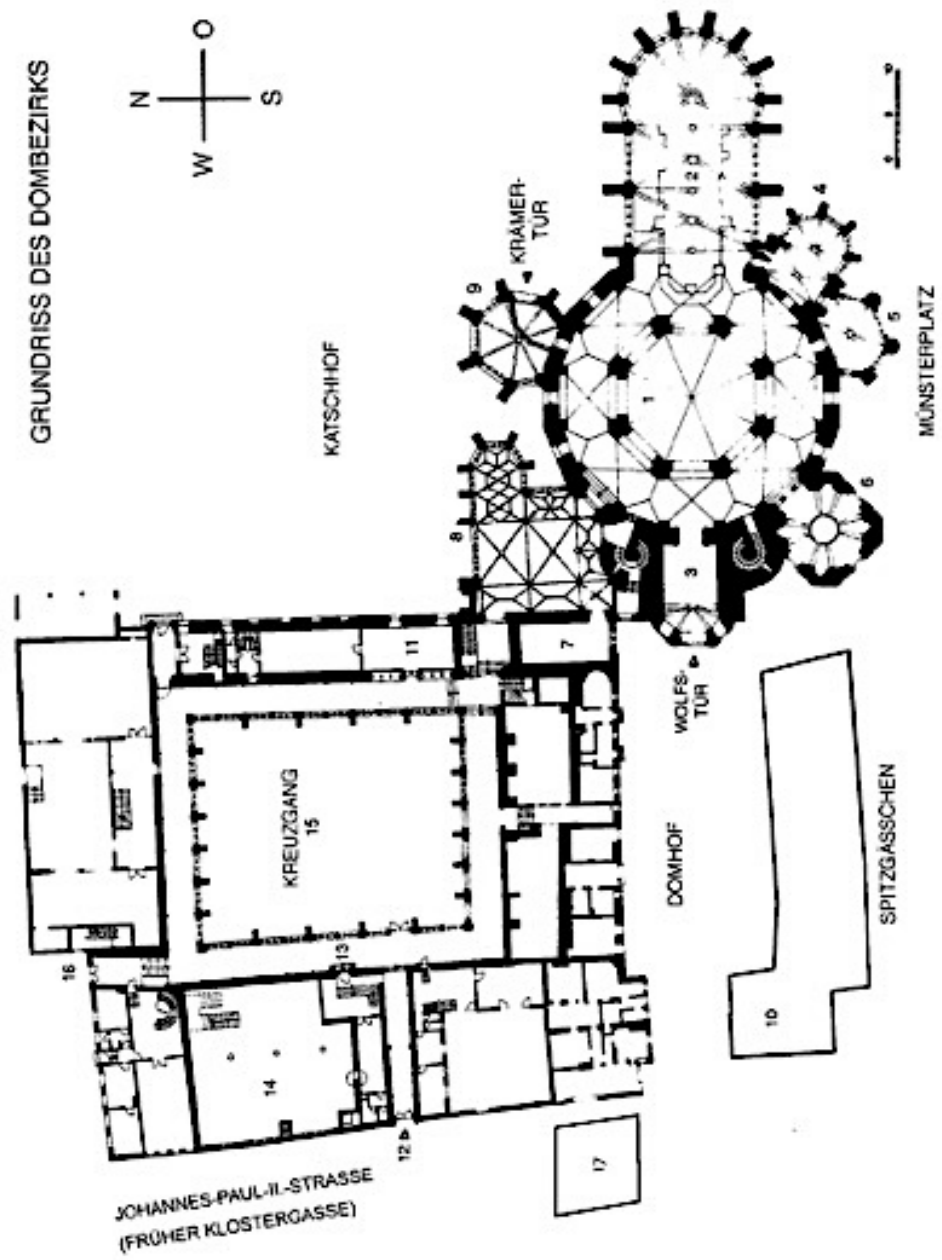

Figure 63: Ground plan of the Cathedral
(LVR, 2012, p. 121)



Figure 64: unknown artist around 1622

(LVR, 2012, p. 156)



Figure 65: Aachen Münster 1853

Artist M. Neher oil painting (section of the painting (LVR, 2012, p. 158))

4.3.2. Stage 2 – analysis

| Stage | Historic Building - Actions | Recording Methods | Action carried out by | Imaging |
|-------|-----------------------------|---|--|---------|
| 2. | Analysis | Analysing the building by surveying in terms of the condition of the building | Conservator/ Archaeologist/ Architect | Yes |

Table 12: The Role of imaging in Stage 2 of Aachen Cathedral's Palatine Chapel's Conservation Project (K. Schütte, p. 86)

With the informed eye gathered from the investigations in stage 1 an analysis of the condition of the masonry took place. Due to the size of the Aachen Cathedral the analysis of the Carolingian masonry of the Palatine Chapel is presented as an example of how stage 2 has been carried out within this historic building (LVR, 2012, p. 73, p.121).

First of all different stone types were identified as having been used for the walling and a mapping of the masonry was carried out. This documentation allowed the observer to identify most of the stone types according to the description of masonry and its origins undertaken by Karl Faymonville. (Faymonville, 2016, p. 82-83).

Both the stone types and also the pointing mortar were investigated and with the visual examination of the masonry and analysis of the pointing mortar the different phases such as repairs or even extensions of the stonework were identified by observation and analysis (LVR, 2012, p. 123-125).

An investigation of the masonry wall led also to knowledge about the construction of the walls, which were built as solid masonry walls (LVR, 2012, p. 129).

Figure 67 is an example of the stone type mapping. The conservators involved identified 13 different stone types, which are marked on this elevation with different colours (Figure 67, p.210). The white areas are unidentified materials. The image of this mapping indicates that the walling was built using different stone types, but also indicates different historic phases of repairs. It is known that the stone type “Herzogenrather” sandstone has been used for repairs (bright yellow on the mapping, date of the repairs is unknown).

All the facts gathered through the analysis of the masonry, its stone types and its mortar, was very important as it informed the intervention work.

Knowledge about the former plaster on the wall identified in Stage 1 made the conservators aware of the likelihood of fragments of this former plaster.

According to the observation work carried out by LVR, the technique of plastering used was called *pietra-rasa*. This technique, which was used during the Carolingian period, is still remaining on the façade even after the removal of the plaster in the 19th century (LVR, 2012, p. 143.)

“Pietra Rasa is a historic technique that combines grouting with plastering on field and quarry stone walls. The excess setting mortar smoothly spreads to the stone surfaces, but the stone heads remain uncovered and visible. Following this, a joint can be pulled with the trowel.”

(Angela Weyer et al. (Ed.): *EwaGlos*. Petersberg 2015, p. 40).



Figure 66: Outside wall of the ruin Ruchenberg: Pietra Rasa with grout marks

The discoveries of the fragments of the plaster also suggest the original colour scheme of the Palatine Chapel according to the research from the LVR (LVR, 2012, p. 149) to be a deep reddish colour.

However, this cannot be confirmed, as the colour scheme is not documented in the form of definite images or descriptions. The fragments of the reddish plaster, discovered on most of the walls, could be of later periods therefore it is still conjecture. After the 12th century minor changes to the Palatine Chapel were documented however the colour might have already been changed by then. Never the less there is an assumption that the reddish colour scheme must be pre 12th century.

In addition to documenting and researching the different colour schemes and the stone varieties from the different stages or building phases of the Palatine Chapel LVR also evaluated the building`s structural performance. For instance,

the octagonal ring beam, which supports the dome over the chapel, was investigated.

According to the conservation management plan stage 2 is well founded through the analysis of the observational findings supported by the historical research results. Still historic buildings always carry secrets, which might never be discovered. As J. Cox writes in her chapter about assessment and recording in the book "Concerning Buildings" (Cox 1996, p. 125) under the heading "*non-intervention*", how frustrating it can be to assess an object without being able to dig a bit deeper. Although new information may be found later in the conservation process when intervention can lead to the discovery of historic evidence including more knowledge of structural performance. The cultural significance of Aachen Cathedral attracts researchers, so it is likely more and more historic evidence will be discovered.

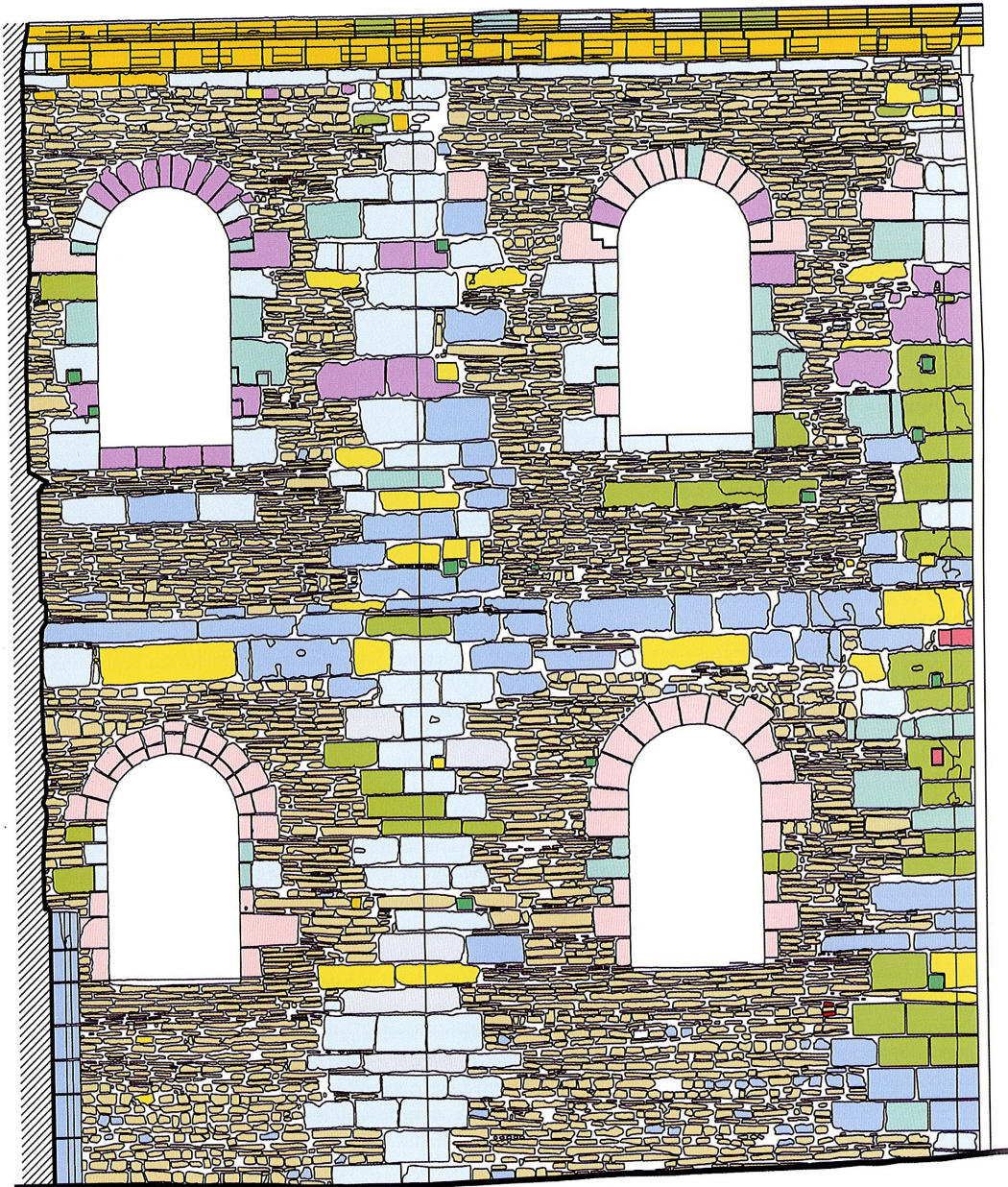

Material

| | | |
|--------------------------|---------------------|----------------------------|
| Grauwacke | Lothring. Kalkstein | Drachenfelder Trachyt |
| Herzogenrather Sandstein | Euville - Kalkstein | Weiberner/Riedener Tuff |
| Pfälzer (?) Sandstein | Jaumont - Kalkstein | Ziegel |
| Roter Eifelsandstein | Travertin | unidentifiziertes Material |
| Blaustein | Savonnières | |

Figure 67: example of one elevation of the material mapping

done by LVR: 96 north elevation material mapping, U.Heckner/ Schaab; drawing by Gottfried Reinhard LVR-ADR (LVR, 2012, p. 170). The legend on the mapping describes the different stone types of the masonry

4.3.3. Stage 3 and 4 – Diagnosis/ Action Plan

| Stage | Historic Building - Actions | Recording Methods | Action carried out by | Imaging |
|-------|--|--|--|---------|
| 3. | Diagnosis Agree and design appropriate actions | Gathered records put together in one documentation – preparing project drawings and specifications incorporating the recommendations of the specialists and consultants. | Conservator, Building Surveyor Structural Engineer, Architect, other Specialists | Yes |
| 4. | Action plan – The project planning, finance, insurance and compliance with legislation including health and safety | Outlining conservation work in form of a document – Preparing the Project programme incorporating the recommendations of the specialists and consultants. | Architect, Conservator, Building Surveyor, Structural Engineer, Project Manager | Yes |

Table 13: The Role of imaging in Stage 3 and Stage 4 of Aachen Cathedral's Palatine Chapel's Conservation Project
(K. Schütte, p. 86)

The different findings from the conservators, the surveyors, the archaeologists and the architects helped to develop an understanding of the Chapel. This included a greater knowledge about its' structure and fabric, which has gone through several changes throughout its history. This is likely to be as significant to the public if this information is displayed, as for the team involved in protecting the structure (LVR, 2012, p. 202).

In addition, the results of Stages 1 and 2 allowed the creation of finite element models, because having knowledge about the construction of the masonry makes it easier to accurately calculate the movements and behaviour of the building. Parts of the chapel and the choir were modelled and incorporated into one comprehensive single model of the entire cathedral (Figure 68, p.213). (LVR, 2012, p. 242). This model was particularly important in the context of

earthquake stability of the building as the model can simulate any movement caused by an earthquake or similar event. It can predict the damage, which may be caused by these sorts of extreme events. These findings from both the surveying and the conservation field from the above stages gave an understanding of the building and its surroundings. This helped the architects and other professionals to create a diagnosis for the site. An action plan could be developed in the following stage (LVR, 2012, p. 242).



Figure 68: entire model of the Aachen cathedral Palatine Chapel and the Choir

(LVR, 2012, p. 242)

The two companies that made the virtual reconstruction of Aachen Cathedral are Narmer Architecture Studio, Budapest (Zsolt Vasáros, Gábor Nagy) and ArchaeoPlanRistow, Köln (Sebastian Ristow).

Gathering all the information about the building, especially for this case study is very complex-because of the development and changes the building has gone through. According to Dr. S. Ristow it is:

“Crucial not to ignore the written evidence from the past, but still be critical about it, because it was and still is well known that written evidence can be part of propaganda.” (Ristow, 2015, p. 369).

Therefore, using the well-known facts about a building gathered by art historians, conservators and archaeologists and leaving out any unreliable speculations based on scant evidence should be the method adopted for a reconstruction. However, Dr. S. Ristow also mentioned that it is crucial not to change any findings, for example bringing the axial curves into a straight relationship with the building. That, as he said would be a misleading or falsifying the facts of the building. It is very important that all the professionals involved in creating a virtual reconstruction should maintain the creation of the real structure and shapes and should never be adjust things to suit a `perfect world`. (Ristow, 2015, p. 365).

4.3.4. Stage 5 – Conservation Work

| Stage | Historic Building - Actions | Recording Methods | Action carried out by | Imaging |
|-------|------------------------------------|--|--|---------|
| 5. | Implementing the Conservation Work | Recording the conservation work in progress and incorporating new knowledge into documentation | Conservator/ Crafts people, Architect, Structural Engineer, Project Manager, other Specialists | Yes |

Table 14: The Role of imaging in Stage 5 of Aachen Cathedral's Palatine Chapel's Conservation Project

(K. Schütte, p. 82)

The action plan agreed within the committee allowed a start to the physical work on the building. The work is being carried out by trained people and over a period of time. Due to the size of the building the work will be on going to protect and keep the structure of the whole Aachen cathedral.

4.3.5. Stage 6 – Documentation

| Stage | Historic Building - Actions | Recording Methods | Action carried out by | Imaging |
|-------|---|---|-----------------------|---------|
| 6. | Post Project Evaluation and Documentation | The Records put together in a final documentation | Conservator/ etc. | Yes |

Table 15: The Role of imaging in Stage 6 of Aachen Cathedral's Palatine Chapel's Conservation Project (K. Schütte, p. 82)

The work was documented and recorded during and after the project. The repairs, which were undertaken, were documented as visual documentation by mapping, finite element models and photographs (LVR, 2012, p. 73 – 76). Each single record including the recording of the decay and analysis of the structure supported the actual work during its implementation and putting all the information together, has produced a well-founded documentation of the building.

The concept of the virtual model

A virtual reconstruction can be made in different ways. Aachen Cathedral has been reconstructed using a CAD based ground plan. From there onwards the building has been modelled.

All the information previously gathered which was non-conjectural was used to begin the model. However, a crucial cooperation with LVR was essential to complete the reconstruction. Although parts of the model could not be authentically reconstructed, as reliable information was not available, the parts, which were based on conjecture, were made clear.

The following illustration shows the process of the reconstruction of the northern basilica. As mentioned earlier these images of the northern basilica were available for the author.

“The 3D reconstruction and animations were done in software Autodesk - 3D Studio MAX, based on the vectored CAD drawings of the excavations. Naturalistic representation of the materials and shading were created with V-Ray renderer, based on findings and photographic materials of the area.” (Ristow, 2015, interview)

Figure 69 (p.218) is the ground plan of the northern basilica which includes findings from an archaeological dig. The two colours in the image present the different findings.

Figure 70 (p.218) is a vectored CAD drawing of the northern basilica.

Finally, Figure 71 (p.219) shows the reconstruction of the external form of the northern basilica.

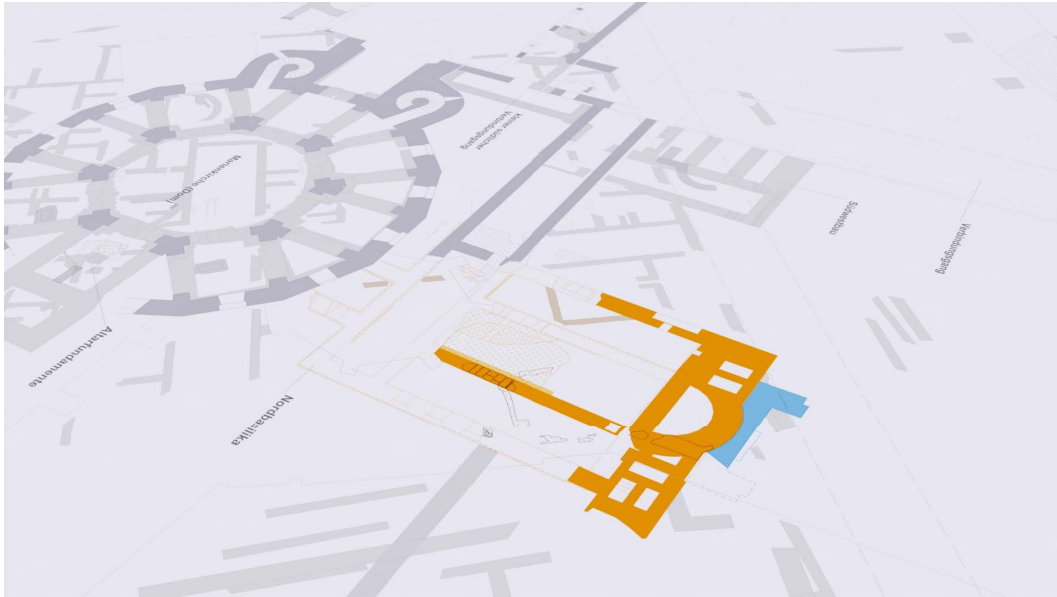

Figure 69: ground plan of the northern basilica

For these figures all rights reserved by Narmer Architecture Studio, Budapest (Zsolt Vasáros, Gábor Nagy), ArchaeoPlanRistow, Köln (Sebastian Ristow)

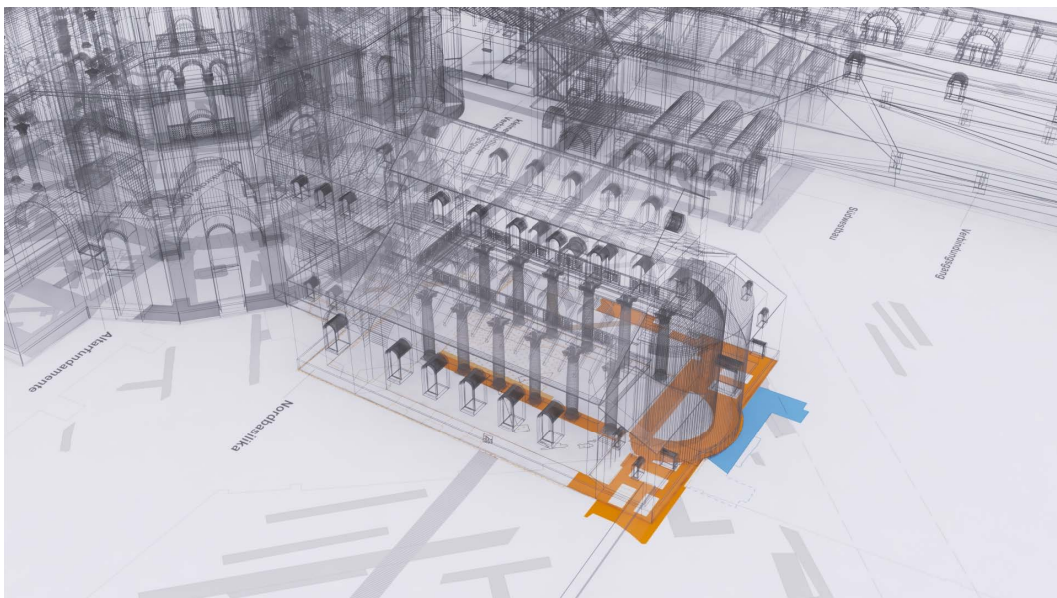

Figure 70: vectorised CAD drawing

For these figures all rights reserved by Narmer Architecture Studio, Budapest (Zsolt Vasáros, Gábor Nagy), ArchaeoPlanRistow, Köln (Sebastian Ristow)

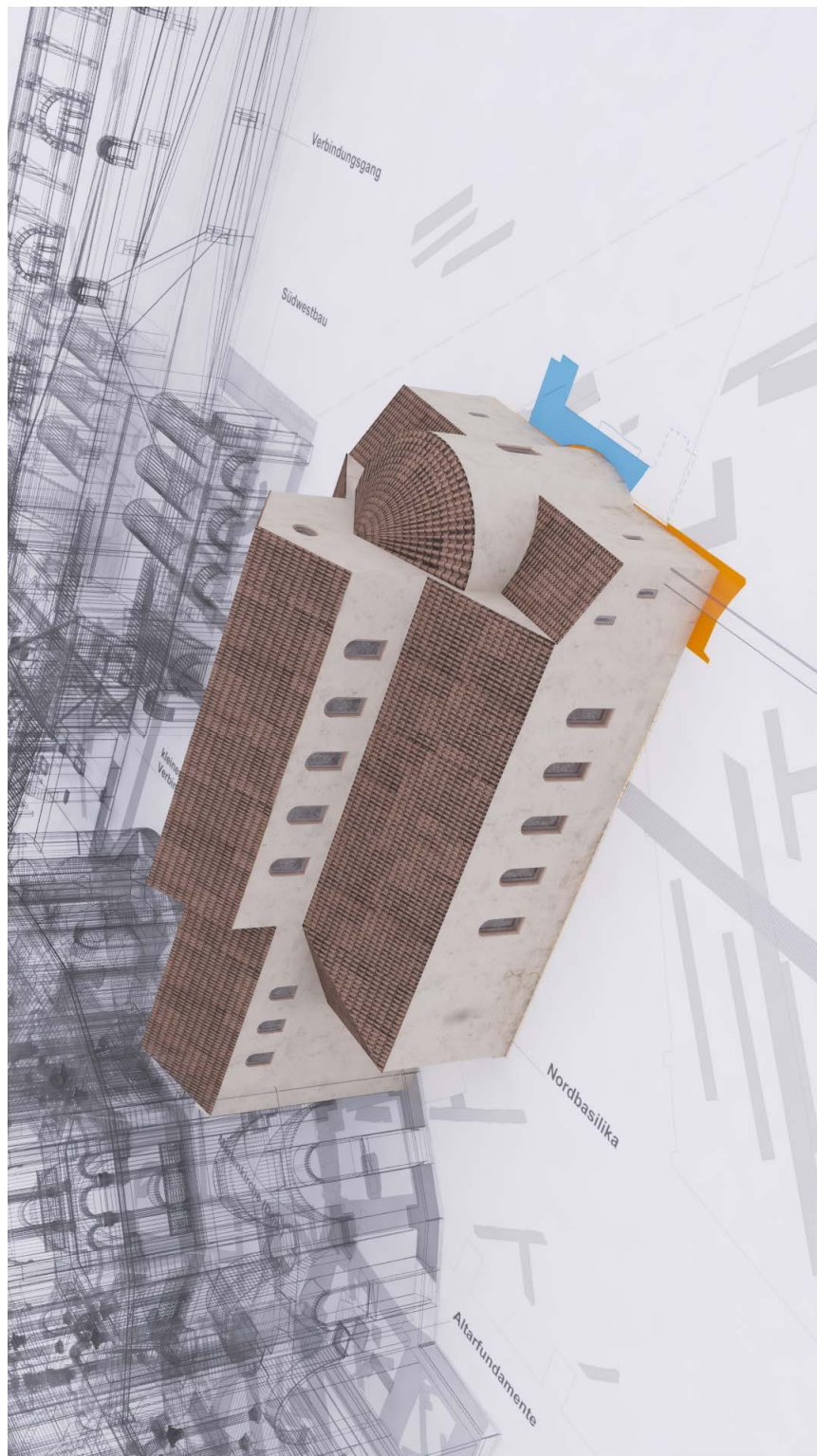

Figure 71: reconstruction

All rights reserved Narmer Architecture Studio, Budapest (Zsolt Vasáros, Gábor Nagy),

ArchaeoPlanRistow, Köln (Sebastian Ristow).

4.3.6. Summary

| Stage | Historic Building - Actions | Recording Methods | Action carried out by | Imaging |
|-------|---|---|---|---------|
| 1. A | Capturing information about the object/ building/ place (Data collection) | Initial survey by observation (Level 1); Recording documentary evidence, historic pictures, photographs, etc. | Conservator | Yes |
| | | | Building Surveyor | Yes |
| | | | Architect | Yes |
| | | | Architecture/ Art Historian | Yes |
| | | | Archaeologists | Yes |
| 1. B | Interpretation of documentation and preparation of findings | Compilation of Historic and Architectural Evaluation Report | Monument officer | Yes |
| | | | Conservator | Yes |
| | | | Building Surveyor | Yes |
| | | | Architecture/ Art Historian | Yes |
| | | | | |
| 2. | Analysis: Establishing the building's condition, understanding materials and construction | Surveying the condition of the building and prepare a report. Risk assessment. Specialists and consultants' reports | Conservator/ Archaeologist/ Architect | Yes |
| 3. | Diagnosis: Agree and design appropriate actions (what is to be done, how and why) | Preparing Project drawings and specifications incorporating the recommendations of the specialists and consultants. | Architect/ Conservator/ Building Surveyor/ Structural Engineer/ other Specialists | Yes |
| 4. | Action plan: The project planning, finance, insurance and compliance with legislation including Health & safety | Preparing the Project programme incorporating the recommendations of the specialists and consultants. | Architect/ Conservator/ Building Surveyor/ Structural Engineer/ Other Specialists/ Project Manager | Yes |
| 5. | Implementation the Conservation Work | Recording the Work in progress and incorporating new knowledge into documentation | Conservator/ Craftspeople/ Structural Engineer/ Other Specialists | Yes |
| 6. | Post Project Evaluation and Documentation | Recording the work in progress and incorporating new knowledge into documentation | Conservator/ Architect/ Project Manager | Yes |

Table 16: The Role of imaging in Stage 1-6 of Aachen Cathedral's Palatine Chapel's Conservation Project (K. Schütte, p.86)

All the stages were followed in detail and good documentation of the work itself was undertaken. Because it is a World Heritage Site all the documentation is accessible to the public and for professionals to understand the building and the intervention, which took place between the years 2000 – 2004.

In this case study photogrammetry supported the conservation work in particular, because through the use of the exact elevations of the facades the mapping of each single stone was possible for both the description and the analysis. The location and the type of each stone also helped to understand the changes, which occurred during the history of the building including the history of its repair.

Reconstructing a virtual model of a historic building is a task which needs a lot of commitment. According to the charters mentioned in Chapter 1 and in Chapter 2 authenticity is crucial.

The infinite model helped and supported an understanding of the building and the conservation work.

Identifying which questions a virtual reconstruction can answer and whether a virtual reconstruction can support scientific research such as archaeology or conservation must be identified and planned in advance. The basis of a good virtual reconstruction is in detailed research work. All the information gathered by professionals such as conservators, architects/art historians and archaeologists are important and only by collecting it all can an authentic virtual reconstruction be created. The result of such a virtual reconstruction is able to show dimensions but may present problems representing the very early construction for example. However, Dr. S. Ristow also mentioned that reconstructions based on CAD drawings can be changed or even extended and when additional information becomes available a new reconstruction of the building can be created (Ristow, 2015, p. 366).

Dr. S. Ristow also mentioned in his article that the interpretation of findings could relate to the understanding of the available research of similar building typologies. Although its value depends upon the quality of the research undertaken. He also warns that research might be influenced by the individual beliefs of the author and political actions (Ristow, 2015, p. 369).

The second case study which focused on the Aachen Cathedral's Palatine Chapel is a good example of documentation and research work. This may be as a result of its World Heritage Site status, but consequently all the information about the building is well archived and accessible. But a virtual reconstruction with reliable facts was not easy to produce. It required a good relationship between the LVR (national bureau of monuments - Rhineland) and the virtual reconstruction companies to ensure all the essential information was exchanged and included in the virtual model.

The importance of this was stressed in the interview with Dr. S. Ristow. The virtual reconstruction is according to Ristow, Figure 71 not accessible to the public, due to a political attitude. However, the author had no further information on this issue.

4.4. Discussion

The case studies used present two independent examples of virtual imaging. Both case studies follow the conservation process discussed in the earlier chapters. Therefore, not only has a virtual image been created but it has also been founded upon strong research work.

The information, which was collected for the first case study about the portal's earlier colour scheme, is now presented in a virtual image, which is a close

representation of the reality. Whether an audience would understand this image is unknown. There is no explanation attached to the image itself, therefore the image could mislead the viewer.

The image itself transports information about the portal's past state and allows professionals to interpret the record. It also can be used for further study. If the virtual image is stored in an appropriate way so it is accessible, it is useful not only for conservators but also for other professions within the field of cultural heritage for identifying and being aware of former colour scheme.

The first case study was also scanned in 2010 after the completion of the conservation work, so the repairs have been documented. The IT technologies used within this case study contain a huge opportunity for future maintenance work. Therefore, the documentation about this work should be accessible for future maintenance work. This can only be the case if a monitoring plan is in place and subsequently carried out. According to the authors' information this has not been accomplished, which reduces the achievement of the work undertaken at the time of the conservation work.

In the first case study the virtual imaging stood alone as an isolated technique. It would be helpful if future generations built a BIM model to keep all the information together. This would allow more information to be incorporated over time especially if the documentation is accessible. However, the development of BIM models for heritage is an on-going research work to become a methodology for the near future (Stylianidis, 2016, p. 114/ 115).

The second case study is, in comparison to the first case study, in a slightly different position due to its status as a UNESCO World Heritage Site. It has been given more attention not only by the public but also within the professional field. Its conservation observes the guidelines of UNESCO. These guidelines define the purpose of all the conservation actions. The cathedral's condition survey is in that case an on going work. The virtual infinite model (p.213) supports the understanding of the structure and its movement, together with the decay of the fabric and the reasons for that decay. Therefore, the model continues to be a useful tool in order to protect this building by knowledge of its structure and fabric. This model can minimise risk through predicting the impact of natural phenomena.

Documentation of the former phases of the site have been incorporated into a virtual image to explain the cathedral's history. This understanding informs the conservation work and management of the site. In addition, having a virtual image means any changes to the building can be incorporated for future evaluation and understanding.

The virtual image also provides comprehensive documentation if parts of the building or the entire building is lost (Lane, 2016, p.1.).

In Chapter 3, the Great Mosque of Aleppo is used as an example of an asset which has been presented, even though the building has been lost (Chapter 3, p. 144).

Therefore, such a virtual record can inform future generations about their past. Lastly the financing of virtual imaging needs to be mentioned. The case studies demonstrate that documentation informs conservation work so it is vital that its cost is always included in the costing of any conservation project (Wood, 1996).

Although virtual imaging may involve further expense when it is incorporated in addition to its use during the conservation project it provides a tool for on-going maintenance and future conservation work as long as the data is made available and the conservation team recognise its value. Several Charters such as *Venice Charter* (1964), and *the Principles for the Recording of Monuments, Groups of Buildings and Sites* (1996), to mention at least two, emphasise that any conservation work should include a well-structured record and documentation.

4.5. Conclusion

Having investigated the role of virtual reconstruction in two case studies, the differences in the reconstructions and their outcomes are obvious. However, in both cases the crucial starting point is thorough research beforehand.

Understanding the building by gathering all the possible information available supports the creation of the most accurate and informed reconstruction as possible. Integrated documentation such as that of the case study from Aachen Cathedral presented an overall collection of data which included historic, archaeological and architectural information (Stylianidis, 2016, p. 253.).

However, as stated earlier in Chapter 2 the purpose of a record needs to be outlined beforehand. Therefore, the purpose of the reconstruction in both cases was certainly defined and fulfilled.

A structured conservation process is needed for the safeguarding of cultural heritage and this includes a structured recording and documentation of the building or object. Therefore, virtual imaging is useful for this field, as it supports the conservation process not only with images, but also with the data behind those images. Nevertheless, without written descriptions and an appropriate

environment in which to present a virtual image the miss-interpretation of it could be possible.

The learning curve during the investigation of the case studies informed the conclusion that not only does a lot of research have to be done before the reconstruction, but also highlighted how important the exchange of information between the professionals involved in the project is. Communication before, during and after the work is crucial for a reliable and accurate image of the building to be developed, as it is across the entire field of cultural heritage. The presentation of virtual imaging is in the first case study temporary, due to the limitations of the exhibit.

As long as the virtual image is preserved well, it could be useful for future presentations. However, there will be a similar problem as with the monitoring. That is remembering what data has been made, where the data is saved and who actual has access to it.

But the most important aspect of virtual reconstruction is the temporary state of a presentation of a building. It represents a moment in time. Knowledge and understanding from any further research can be added to that model to create a more authentic model. But to enable-remodelling the working process creating the data has to be well documented and the data also needs to be exchangeable (London Charter, 2009/ 2013). Also, it can be used to understand the building and inform professionals and the public through remote platforms such as the World Wide Web.

Chapter 5 - Conclusion

The aim of this research was to explore whether there is a role for virtual imaging in building conservation based on the following objectives:

- i.)* To present the internationally agreed conservation process and explain how the conservator interfaces with that process.
- ii.)* To identify the documentation necessary at each stage of the process with an emphasis upon the documentation required by the conservator.
- iii.)* To establish the purpose of imaging in conservation and explore the technology required producing virtual images including issues that arise through its usage, in particular appropriateness and ease of interpretation when creating a reconstruction of cultural heritage.
- iv.)* To identify and critically assess examples which utilise virtual imaging as a documentation tool to establish where imaging fits in the conservation process.
- v.)* To investigate two case studies which have successfully integrated virtual imaging in their conservation project.
- vi.)* To reflect on the issues identified to establish the advantages and disadvantages of the technique and how it can benefit a conservation project.

Due to the professional background of the author the research is focused on the work of conservators and establishing exactly how virtual imaging can support

conservation work. The hypothesis in Chapter 1 stated: “Conservation work is strongly influenced by IT based technologies today. Can the increase of IT based imaging support the documentation, recording, interpretation and specification in building conservation?”

In Chapter 1, the relevant literature was explored, discussed and key concepts have been identified in relation to imaging. Within the literature there are charters, guidelines and principles, which are important for identifying ethical beliefs in conservation and these must be followed even when producing virtual images of historic buildings as is stated in the Principles of Seville. All practitioners should respect the code of ethics and not mislead the public with false information about a building. The literature concerning virtual and digital methods for imaging was also analysed and the technology being used is vast and still developing meaning the results are becoming more and more accurate. This is an advantage for the documentation of cultural heritage as the more exact the measurements, the better the structure of the building can be explored, or the materials of the building can be better analysed and be more precisely understood. The management of the building also becomes easier, because more accuracy means more detailed information about the building. Being able to widen the knowledge base regarding the usage of the different tools makes the outcome is even better. As mentioned in the literature a lot of the methods discussed have been used within the area of archaeology first, and then a transfer of knowledge from this field into the conservation field is possible.

In Chapter 2 Table 1 (p. 86) was created to demonstrate the stages where a conservator could be involved and also where an image is supportive in this process. The table shows that each stage can be supported by images, although the type of image depends on the aim of the project. The table also explains what value and information an image can add and it has been developed to relate specifically to the work of a conservator regarding documentation within the conservation process. This method has allowed attention to be drawn to documentation within the conservation process and how supportive imaging can be in understanding historic buildings.

All historic assets, including buildings and objects should be well recorded at the start of the conservation project as pointed out in Chapter 2.

Chapter 1 and 2 explored how important it is to understand historic buildings, especially when creating a virtual record (ICOMOS, 1979, 1981, 1988).

Documentation including past images, supports informed observation when establishing the historical development of a building. The narrative of the building is as important as the physical building itself. This knowledge allows an understanding of both tangible and intangible values to establish the significance of the building (Lane 2016).

Through the examples presented in Chapter 3, reviewing the technologies available on the market and presenting an analysis of how they are used within the field of cultural heritage and considering the outcomes and success of their use have examined virtual imaging. The findings suggest that the value of virtual imaging is dependant on the questions asked before hand, not all virtual images are supportive of the conservation process or the final documentation

process. Understanding historic buildings was discussed in relation to the key concepts, which included the relevance of documentation. Documentation is here referred to as a collection of records, which includes imaging as well as the written word. However, the purpose and use of virtual images needs to be carefully considered.

However, a precise strategy must be outlined first as to what will be recorded with the virtual image. Being aware that IT-based technologies will be used more and more for documentation purposes in cultural heritage means that the production process of the virtual image must be recorded as well. This is a crucial issue as Wood (1996) points that out. Without any knowledge about the technology used, the virtual documentation is not helpful for future generations. A conservator can support the conservation process in different stages depending upon the work experience as described in the E.C.C.O booklet and explained in a diagram (Appendix 3), (Hutchings and Corr, 2011).

The established conservation process is a framework, which helps to identify the need for single imaging. It is clearly stated by UNESCO how important documentation is for World Heritage Sites, as is shown in the second case study in Chapter 4.

Chapter 3 analyses virtual modelling techniques more generally. This chapter gives an overview of common IT-based techniques used in cultural heritage for documentation. GIS, BIM and different scanning techniques such as terrestrial laser and white light scanners and photogrammetry are explored.

The examples investigated have been chosen from the World Wide Web, from the author's work experience, from conferences and from Historic England's booklets. Overall these examples of the use of documentation as a tool are positive. The selected project aims vary so the methods used for capturing data also vary from one project to another. Most projects use a combination of several tools, as shown in the examples-in Chapter 3 including Iron Bridge, by English Heritage. One of the advantages of combining different techniques within a virtual record of a building is that more information about material, measurements and ontology can be incorporated. Another advantage of combining different tools is that the virtual images and the virtual records can be used for more than one purpose, again as shown at Iron Bridge, where English Heritage has included a public educational aspect.

Two examples in Chapter 3 presented under the paragraph 3.3.1. Virtual Presentation of Ancient Heritage allows the visualisation of former impressive buildings. The Ishtar Gate and the Temple of Demeter have been chosen from the World Wide Web as they are useful examples of how images such as this may be falsely interpreted without knowledge or understanding of the building. Only by comprehensively explaining how the image was created and whether any conjecture was used can the historic building be fully understood. Without any explanation, there will be much less educational benefit for the user. Therefore, digital images should always be introduced with reference to the documentation process used in its production to avoid any misunderstanding.

The Ishtar Gate was a good example to use in order to illustrate a reconstitution using original fabric and both actual and virtual reconstruction. The Booktower of Ghent was presenting BIM and semantic technologies. With this example, the recording methods especially for conservation work can be supported.

A virtual reconstruction within a documentation keep the future generations informed about its appearance, dimensions, depths of walling, information about former colour scheme, for instance. The advantage of having a digital record is certainly in the improved quality a content of information included and the possibility of continually extending the document.

Chapter 4 investigated two case studies, which were chosen to illustrate the conservation work and the alignment of the virtual imaging in a conservation process. The first case study, the portal of St. Kastulus Münster, Moosburg a.d.I, Germany, was a project, which was restored by the author herself.

Therefore, good access to and knowledge about the project supported the analysis. In the conservation process imaging was found to be supportive at each stage. The virtual reconstruction of a former colour scheme had been produced from the structured mapping and an analysis of the remaining fragments of paint layers on the exterior of the portal. The purpose of the virtual reconstruction was for display in an exhibition encouraged by the diocese of Munich/ Freising, Germany. The colour scheme of the former phase of the portal, which was reconstructed, is not obvious to the untrained eye. Therefore, the image presented was a surprise for some in the audience and therefore informed them about the history of the object. The advantage of using a virtual

image such as this is that it is `reversible` and does not influence the physical portal and its appearance today. Also, any additional information that comes to light about the portal can subsequently be added to a virtual image.

The scanning of the surface of the portal was used for monitoring purposes.

The conservation work has been recorded and the data could be used to inform future management about the portal. According to the maintenance plan the monitoring should be repeated after five years. Unfortunately, this did not happen according to Dr. H. Rohrman, the person responsible for this project from the diocese of Munich/ Freising. The reason is unknown but the opportunity to undertake regular monitoring with the aid of a virtual image remains an advantage.

The second case study was the Aachen Cathedral. This building was chosen due to its status as a World Heritage Site. The recording and documentation methods were of a high standard and therefore the building`s management and conservation team have been well informed, although there are still a lot of unknown areas where research work is continuing. The virtual reconstruction did support the hypothesis of both the archaeologists and the other researchers in the construction of the former buildings.

Virtual imaging is certainly a valid recording tool for building conservation, and the technologies related to it should be used more and more in conservation.

For instance, models such as a finite model used to simulate daily impacts of construction on a buildings fabric and structural performance can support the conservation management plan. Methods such as BIM, photogrammetry or

even phase studies can support the conservation work; the main issue is that a good record is needed for authentic virtual reconstruction, but also a good record of the virtual reconstruction.

Both case studies show how the conservator may be supported by virtual images. One example of this is during the research stage, project virtual images can assist in developing an understanding of the building. This knowledge can then inform decision-making and later support the actual work and future monitoring. In fact, in all the processes with which the conservator could be involved under the supervision of the professionals in charge.

The crucial issue for virtual imaging as a recording and documentation tool is certainly in the planning beforehand. Which techniques should be used and for what purpose all need to be defined by the project team of various professional experts before an overall strategy is put into place. Another issue, which can arise, is a language problem between the different disciplines that need to be involved in the creation of a virtual image. Therefore, a nomenclature for the usage of IT based technologies in the field of cultural heritage should be developed and unambiguous definitions agreed internationally.

Virtual imaging is certainly a valid recording tool for heritage, and the technologies should be used more and more in conservation. However, the IT based technologies, which are supporting the recording of cultural heritage, could be listed on an information platform. This platform should be accessible to all professionals involved in conservation work.

The framework of the research allowed the author to identify the limitations of virtual imaging in the conservation work. As outlined in Chapter 2, successful conservation work is based on effective teamwork. The experts involved in a project should inform each other and the available money should be spending wisely. Therefore, communication is crucial in order to achieve the best possible result. The field of conservation has been widened to include many different professionals due to the use of IT based technologies, however the knowledge gathered especially by the conservators should be more involved in the overall process.

Issues such as available techniques and what is achievable regarding historic buildings should be identified and put together on an available and accessible platform. It is important to find solutions for the questions about how to make IT based technologies more worthwhile in building conservation and the tendency to create virtual images of historic buildings without any purpose should be controlled.

IX. Glossary

This section includes the nomenclature of specific words used in this research.

3D –

Having three-dimensions characterised by Cartesian (x, y, z) co-ordinates. (English Heritage, 2011, p. 19)

3D reconstruction –

A creation of a three dimensional model from a set of images

Assets –

Valuable building

Authenticity -

Means the credibility or truthfulness of the surviving evidence and knowledge of the cultural heritage value of a place. Relevant evidence includes form and design, substance and fabric, technology and craftsmanship, location and surroundings, context and setting, use and function, traditions, spiritual essence, and sense of place, and includes tangible and intangible values. Assessment of authenticity is based on identification and analysis of relevant evidence and knowledge, and respect for its cultural context. (ICOMOS NZ 2010, p. 9)

Building Conservation -

The process of managing change to a significant place in its setting in ways that will best sustain its heritage values, while recognising opportunities to reveal or reinforce those values for present and future generations, *Conservation Principles*, English Heritage, 2008, p. 71

“All operations designed to understand a property, know its history and meaning, ensure its material safeguard and, if required, its restoration and enhancement.” The Nara Document on Authenticity (ICOMOS 1994)

CAD –

Computer-aided design (CAD) is the use of computer technology to aid in the design and especially the drafting (technical drawing and engineering drawing) of a part or product, including entire buildings. It is both a visual (or drawing) and symbol-based method of communication, whose conventions are particular to specific technical field. (Andrews, 2009, p. 62)

Charter –

Regarded as central and internationally recognized guideline in the preservation of monuments. It defines key values and procedures for the conservation and restoration of monuments. (ICOMOS Venice Charter, 1964)

CIDOC CRM –

Conceptual Reference Model (CRM) provides definitions and a formal structure for describing the implicit and explicit concepts and relationships used in cultural heritage documentation.

The CIDOC CRM is intended to promote a shared understanding of cultural heritage information by providing a common and extensible semantic framework that any cultural heritage information can be mapped to. It is intended to be a common language for domain experts and implementers to formulate requirements for information systems and to serve as a guide for good practice of conceptual modelling. In this way, it can provide the "semantic glue" needed to mediate between different sources of cultural heritage information, such as that published by museums, libraries and archives. <http://www.cidoc-crm.org>

CIDOC CRM (Conceptual Reference Model)–

is the culmination of over 10 years work by the CIDOC Documentation Standards Working Group and CIDOC CRM SIG which are working groups of CIDOC (Cidoc-crm.org, n.d.)

(International Council of Museums (ICOM), 2013)

Code of ethics in conservation–

Is understood as statements internationally agreed for the protection of cultural heritage, which is founded on a few strong principles. (Bell 1997, p. 27)

Truthful and honest

Conjecture –

Conjectural work in conservation means re-creating s.th. As nearly as possible to some conjectured (and thus unproven) traditional state. (Council, 1997/ 98)

Conservation Management Plan -

A conservation plan, which also sets out, a specific set of actions or proposals for the management of the site. (Clark, 2001)

Conservation plan -

Means an objective report which documents the history, fabric, and cultural heritage value of a place, assesses its cultural heritage significance, describes the condition of the place, outlines conservation policies for managing the place, and makes recommendations for the conservation of the place. (ICOMOS NZ, 2010, p. 9)

Conservation process –

Conservation management plan

Conservation work –

Managing changes of significant buildings

Cultural Heritage –

Cultural Heritage is an expression of the ways of living developed by a community and passed on from generation to generation, including customs, practices, places, objects, artistic expressions and values. Cultural Heritage is often expressed as either Intangible or Tangible Cultural Heritage

It is a material and spiritual resource, providing a narrative of historical development. (ICOMOS, 1999)

Cultural Significance –

Means aesthetic, historic, scientific, social or spiritual value for past, present or future generations.

Cultural significance is embodied in the place itself, its fabric, setting, use, associations, meanings, records, related places and related objects.

Places may have a range of values for different individuals or groups. (ICOMOS Burra Charter, 1979, 1981, 1988) Art. 1, 1.2

Digital –

Is defined for this research as: virtual version of a physical object.

Digital and virtual imaging –

In this research the term digital and virtual imaging has been used as: IT-based imaging.

Documentation -

The collection of all records

Means collecting, recording, keeping, and managing information about a place and its cultural heritage value, including information about its history, fabric, and meaning; information about decisions taken; and information about physical changes and interventions made to the place. (ICOMOS NZ, 2010), p. 9)

Fabric –

Means all the physical material of a place, including subsurface material, structures, and interior and exterior surfaces including the patina of age; and including fixtures and fittings, and gardens and plantings. (ICOMOS NZ, 2010, p. 10)

Guidelines –

Agreed standards

Historic Building –

House, castle, etc., from a certain period of time, which is seen as having historically significant to the public.

Historic Building documentation –

Is documentation, about building

IFC – “Industry Foundation Class, an object-based open standard for the exchange of BIM information between different software. Developed by ‘building SMART’, a global alliance specialising in open standards for BIM, IFC is an official standard, BS ISO 16739, and contains geometric as well as other data.” (Historic England, 2017, p. 66)

Italian Normative UNI –

“Italian Normative UNI 10838 - Building.Terminology for users, performances, quality and building process,”1999. - “Italian Normative UNI 8290 - Residential building. Building elements. Classification and terminology,” 1981. (Pauwels, 2013)

Laser –

“Light amplification by stimulated emission of radiation: an electronic- optical device that emits coherent light radiation.” (English Heritage, 2011, p.19)

Laser Pulse –

See Laser and Pulse Duration

Laser Scanning –

“Laser scanning is a method for the automated mass capture of 3-D points at fixed intervals. The scanner is used to create a” point cloud” of the surface of the subject. These points can be used to exploit the shape of the subject. If colour or reflectance intensity information is also collected at each point, then this can also be mapped.” (Andrews, 2009, p. 63)

Mapping –

The action of map; it is a form of a condition survey

Measurements, direct and indirect –

“**Direct measurement** is the method of measurement in which an object whose measurements are needed, is measured directly. According to **indirect measurement** technique, the object whose measurements are required, is not measured directly; on the other hand, some other object is measured.” (Anon, 2018)

Model –

“An expression that should be qualified by the type of model, e.g. geometric model. A geometric model is, typically, a digital representation of a three-dimensional shape.” (English Heritage, 2011, p.19)

Object –

Anything not (now) fixed to or incorporated within the structure of a place, but historically associated with it, (Drury, 2008, p. 72)

Photogrammetry –

The technique of using photographs to obtain measurements of what is photographed, esp. in surveying and mapping.

Point cloud –

See laser scanning (Andrews, 2009, p. 63)

Point density –

The average distance between XYZ co-ordinates in a point cloud. (English Heritage, 2011, p. 19)

Preserve –

To keep safe from harm⁵⁷

Process -

A series of actions or steps taken in order to achieve a particular end.

Property -

A building with land belonging to it

Principles –

Guidelines

Pulse Duration -

“A measurement of the total amount of time that a pulse is emitted; also known as pulse width.” (Teanecklaserdentist.com, n.d.)

Range –

Distance

⁵⁷ The legal interpretation established in *South Lakeland DC v Secretary of State for the Environment and Rowbotham*

[Aachen Cathedral] Aachen Cathedral L.P.R. Aachen Cathedral

RDF - Resource Description Framework

Standard model for data interchange on the Web

Reality –

1 what exists or is real; that which underlies and is the truth of appearances or phenomena.

2 the quality of being real or having an actual existence.

5 a real thing, fact, or state of affairs; the real nature of something b that which constitutes the actual thing, as opp. To what is merely apparent or external.

6 resemblance to what is real or to an original.

Reassembled –

Bring together again

Reconstitution –

“Describes the piece-by-piece reassembly of a structure either in situ or on a new site. Reconstitution may be the result of disasters such as wars and earthquakes or it may be caused by land use changes which necessitate the relocation of a building.”

(lp51.icomos.org, n.d.)

Reconstruction -

Means’ returning a place to a known earlier state and is distinguished from restoration by the introduction of new material into the fabric. (ICOMOS, 1979, 1981, 1988) Art. 1, 1.8

“Means to build again as closely as possible to a documented earlier form, using new materials. “(ICOMOS NZ, 2010)

Record/ Recording -

In this research the term record is defined as a part of a documentation, which is describing the building, e.g. in a written, photographic, drawn form.

Replication –

Exact copy of an original object

Reproduction –

The act or process of reproducing

Restoration –

To return a place to a known earlier state, on the basis of compelling evidence, without conjecture

Ruin –

The state of a fabric or structure, which has given way and fallen down; esp. the remains of a decayed and fallen building, town, etc.

Semantic Web Technology –

Enable people to create data stores on the Web, build vocabularies, and write rules for handling data

(W3.org, 2015)

Scientific based work –

Accurate documentary information

Significance –

Described in “Conservation principles, policies and guidance” from English Heritage: Significance [of a place]The sum of the cultural and natural heritage values of a place, often set out in a statement of significance

Significant place –

A place, which has heritage value(s)

Site –

A collective term for places, buildings, landscapes and locations

Terrestrial laser Scanning –

“Any ground- based laser device that collects 3D co ordinates of a given region of a surface automatically and in a systematic pattern at a high rate achieving the results in (near) real time.” (English Heritage, 2011, p. 19)

TST –

Total station theodolite (Andrews, 2009, p. 63)

Value –

“Conservation of cultural heritage in all its forms and historical periods is rooted in the values attributed to the heritage. Our ability to understand these values depends, in part, on the degree to which information sources about these values may be understood as credible or truthful. Knowledge and understanding of these sources of information, in relation to original and subsequent characteristics of the cultural heritage, and their meaning, is a requisite basis for assessing all aspects of authenticity.” (ICOMOS, 1994, p. 46/ 47)

Virtual –

“Computer based Visualisation: the process of representing information visually with the aid of computer technologies London.” (Denard, 2009)

Virtual imaging –

“Virtual Imaging” is computer-based process, which involves the non-physical reconstruction of a phase or moment in time. It is a visual documentation tool, which also incorporates information about an object, building or place for instance historical information, future changes and interventions etc.

Virtual reconstruction –

“This involves using a virtual model to visually recover a building or object made by humans at a given moment in the past from available physical evidence of these buildings or objects, scientifically-reasonable comparative inferences and in general all studies carried out by archaeologists and other experts in relation to archaeological and historical science.” (LOPEZ-MENCHERO, 2011, p. 3)

White light Scanner –

“Scan data is obtained shot by shot, as a grid of light is projected and laid over the component being scanned.”
(Exactmetrology.com, n.d.)

X. Appendices

Appendix 1: Ethical approval form

RE: Outcome of research ethics application - Kathrin Schuette

01.01.18, 14:09

RE: Outcome of research ethics application

Claire Butcher on behalf of Arts Research Ethics

Thu 26/05/2016 10:15

Inbox

To: Kathrin Schuette <kathrin.schuette@plymouth.ac.uk>;

Cc: Linda Watson <L.Watson-2@plymouth.ac.uk>;

Dear Kathrin

Thank you for submitting your revised ethics application. I am pleased to confirm that you have addressed the committee's concerns and you now have ethics approval for your research.

Kind regards

Claire

From: Kathrin Schuette
Sent: 16 May 2016 16:07
To: Claire Butcher
Cc: Linda Watson; Katharine Willis
Subject: Re: Outcome of research ethics application

Dear Claire,

please find enclosed my ethical form application.

I hope this one can be approved.

Kind regards,
Kathrin Schuette

From: Claire Butcher
Sent: 29 April 2016 16:49:09
To: Kathrin Schuette
Cc: Linda Watson
Subject: Outcome of research ethics application

Dear Kathrin

The outcome of your application for research ethics approval is attached.

Regards

Project title:
“The Role of Virtual Imaging in Building Conservation”

MPhil Researcher: Kathrin Schuette
Contact details: *kathrin.schuette@plymouth.ac.uk*

Academic Supervisors: Linda Watson and Katharine Willis,
School Architecture, Design & Environment, Plymouth University

Information Sheet

Project: Is there a role for virtual imaging in building conservation?

What is this project about?

Computer animated reconstruction of cultural heritage has become a popular tool in recent years for art historian, archaeologist but also for conservators.

The focus of my research is on ruins and lost buildings and their restoration and the role of virtual imaging. This interview is to understand your role in the conservation process and how you may have used virtual imaging in the conservation project. The interview will last approx. 30 minutes and will be voice recorded.

I am hoping that interviewing experts in virtual reconstruction will enrich the literature I considered and allows to present the thoughts of experts according to virtual reconstruction in building conservation. My case studies do need the knowledge from the people who have been involved in these projects therefore I do believe that interviewing them will lighten up the case studies.

Confidentiality

You will be acknowledged and named in the thesis. This is because Your role in the conservation process is important the description for the research. You will be named in the MPhil thesis and You will be given a copy to review before the final submission is made. All information gathered during the course of the project will be securely stored and archived for 10 years as per the University of Plymouth Ethical Policy.

The right to withdraw

As a participant, if you decide you do not want to participate you will be given the opportunity to withdraw up to the end of the survey-gathering period on 31st May 2016.

Planned Outputs

After data collection, the results will be included in an MPhil thesis that will be submitted to the School of Architecture, Design and Environment and maybe published in academic journals at a later date.

Debrief

Participants will be contacted at the end of the project with information about the outcomes of the research. This will be the latest by the end of 2016. You will be informed by email (If you do not want to be included in this debrief process please let me know.)

Feedback: Please contact *me* at any time if you have questions regarding the informed consent or this research study. Furthermore, you may obtain information on my progress / request copies of outputs at any time *kathrin.schuette@plymouth.ac.uk*

If you have any questions about the project or your information, please contact me.

This work is being undertaken as part of an MPhil in Plymouth University School Architecture, Design & Environment

2010 - 2016

Questions for the participants:

- 1.) What was the intention behind creating a computer-based reconstruction?
5. 2.) What type of base material such as surveys etc. did you use for the reconstruction?
- 3.) What type of technique has been used and why?
6. 4.) Who was part of the team? And why? Or why not?
- 5.) How did the reconstruction help/ support your work?
7. 6.) Is it supportive for conservation work?
- 7.) Is your reconstruction used as a recording tool/ analysis tool?

Appendix 2: Questionnaire

Fragebogen - BLfD/ Diözese

Kathrin Schütte

Herangehensweise der Konservierungsarbeiten am St. Kastulus Münster, Mossburg a.d.Isar

Westportal

Meine Thesis betrachtet virtuelle Rekonstruktionen/ virtuelle Technologien, die in der Konservierung zur Anwendung kommen können und diese Arbeit ggf. unterstützt.

Fragen:

1. Anhand welcher Erkenntnisse vor allem vom wem (Architekt/ Denkmalpfleger/ Diözese) wurde eine notwendige Maßnahme am Portal festgestellt?
- diese Frage bezieht sich auf den Prozess, der für Maßnahmen an Denkmälern durchlaufen werden sollte, bezogen auf „Regeln“ basierend auf Carta von Venedig und den Richtlinien der Denkmalpflege (BLfD) und der Diözese. Hat die Diözese München/ Freising eigene Richtlinien in Bezug auf Herangehensweise/ Arbeitsschritte/ Maßnahmenplan?
2. Welche Arbeitsgruppen waren im Findungsprozess eingebunden? - Wurde der Zustand im Vorfeld vom Denkmalamt oder dem Bauherrn beurteilt?
3. Welche Fachleute wurden dann involviert?
4. Ab welchem Zeitpunkt der Findungsphase wurden Restauratoren einbezogen?
5. Wer hat das Monitoring des Portals initiiert? Und unter welcher Begründung?
6. Was war der Grund für eine virtuelle Rekonstruktion des Portals? (diese Frage ist glaube nicht von Ihnen zu beantworten, da dies eine freie Entscheidung der Diözese war, oder?)
7. Welche Vor- oder Nachteile können nach Abschluss der Rekonstruktion gezogen werden? Im Besonderen aus der Perspektive der Konservierung.

Is there a role of virtual imaging in building conservation?

Translation of the questionnaire:

1. On the basis of which knowledge, especially by whom (architect / monument conservator / diocese) was a necessary measure determined on the portal? This question refers to the process that should be followed for action on monuments related to "rules" based on Carta of Venice and the Guidelines of Conservation (BLfD) and the diocese. Does the Diocese of Munich / Freising have their own guidelines regarding the approach / working steps / action plan?
2. Which working groups were involved in the identification process? - Did the Monument Office or the client assess the condition in advance?
3. Which experts were involved then?
4. At what point in the identification phase were restorers involved?
5. Who initiated the monitoring of the portal? And under what grounds?
6. What was the reason for a virtual reconstruction of the portal? (This question is not to be answered by you, since this was a free decision of the diocese, right?)
7. What advantages or disadvantages can be drawn after completion of the reconstruction? In particular, from the perspective of conservation.

Appendix 3: 2 Diagrams taken from: Corr, 2011, p. 40-43, *Competences for access to the conservation-restoration profession*

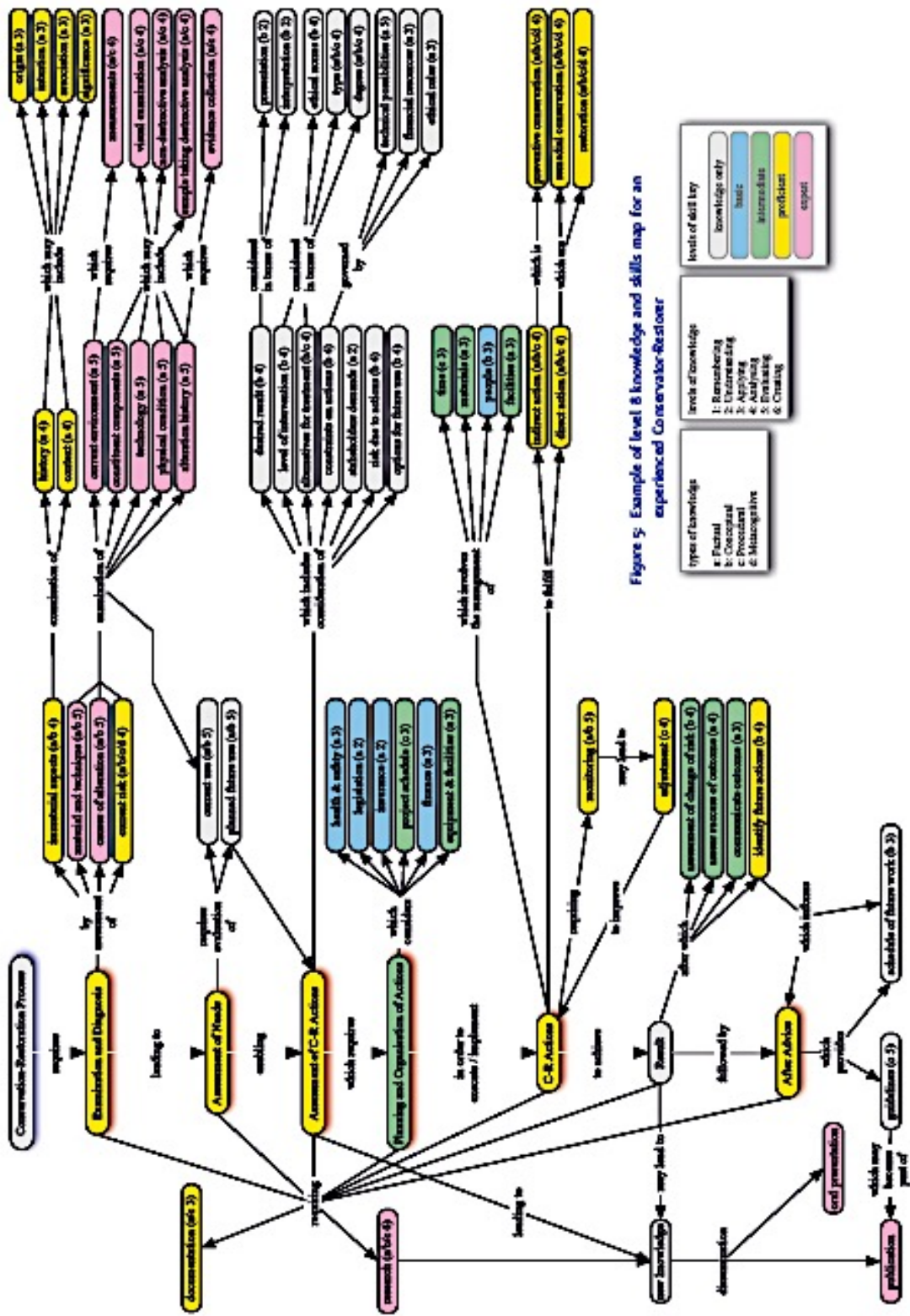

Figure 5: Example of level 8 knowledge and skills map for an experienced Conservator-Restorer

(Corr, 2011), p. 40, 41

Appendix 4: English Heritage, 2011, *3D Laser Scanning*, p.9

“2.2 Software

Computer software is required at each stage of the laser scanning process. This includes the operation of the scanner, the processing of the collected data and the visualisation and utilisation of any delivered digital product. Operation of the scanner is likely to be handled by a contractor. Here the discussion is restricted to describing software for processing the collected data (also likely to be done by the contractor, but given here to provide an overview), and software that a user may need for viewing and using the final deliverables.

The choice of software will be based

on a number of factors, including data quantity, the type of deliverable output required and user expertise and skill. The process of turning a point cloud into useful information is covered in section 5 below. However, it is useful to highlight here

the significant components of software specially designed to be used with point cloud data. Such software will offer a three-dimensional viewer that can be used to preview the dataset. It will enable the view to be rotated, zoomed and panned, colours to be changed and data to be clipped from view. The software will have been designed specifically to handle large volumes of three-dimensional measurements. Mainstream software for CAD, GIS or 3D modelling was not originally designed to handle the large datasets now routinely generated by laser scanning. In some cases specialist point cloud processing engines can be obtained to improve the performance of these mainstream tools, making it possible to use a familiar software environment; also, many software providers are currently in the process of repackaging their software to meet the needs of laser scanning data.

A user who is commissioning a laser scanning survey is unlikely to need to consider exactly what software to use to process the collected data; rather, he or she will need to ensure that the methodology is appropriate for the needs of the project. The user will, however, need to ensure that the final product, generated from the point cloud, can be used for the task intended.

It may be necessary to manipulate this within a standard desktop CAD or GIS package, or may require specialist software to enable easier visualisation and analysis.

Free viewers designed for standard and proprietary formats are available, and low cost tools, designed to give a little more flexibility (such as the ability to make simple measurements), can be readily obtained. A good data provider should be able to provide a client with information on appropriate software to meet his or her needs. For more information on particular products, see section 7 Where to find out more.

2.3 Computer hardware

A standard desktop PC designed for general office use may be insufficiently powerful

to take full advantage of the generated product, or for the proposed analysis.

However, desktop PCs with computing power and specifications suitable for the day-to-day use of large geometric models (assuming appropriate software is installed) are now widely accessible and less expensive. Those planning to buy a new computer or upgrade an existing one in preparation for the use of three-

dimensional data should refer to the minimum recommendations of individual software packages and consider the following points.

- 3D graphics acceleration: Having a dedicated 3D graphics card is one of the most important features. Note some off-the-shelf machines provide 3D acceleration through integrated cards that share the computer's standard memory. Although less expensive this type of card should be avoided.
- RAM: The more the better. Memory is normally installed in pairs of modules, so when buying a new computer, consider what will be the most cost-effective way to add more memory in the future.
- Hard disk: Significant disk space will be required for day-to-day storage. Consider using an external hard disk to provide a local backup.
- Display: Do not underestimate the value of choosing a good quality monitor.
- Processor speed and type: While having a fast processor may improve general performance, it is less important than are graphics card and RAM.”

Appendix 5

Garcia, B., 2013:

“The Ishtar Gate was constructed by the Babylonian King Nebuchadnezzar II circa 575 BCE. It was the eighth gate of the city of Babylon (in present day Iraq) and was the main entrance into the city. The Ishtar Gate was part of Nebuchadnezzar's plan to beautify his empire's capital and during the first half of the 6th century BCE, he also restored the temple of Marduk and built the renowned wonder: the Hanging Gardens as part of this plan. The magnificence of the Ishtar Gate was so well known that it made the initial list of the Seven Wonders of the Ancient World. However, it was later replaced by the Lighthouse of Alexandria, but some authors (Antipater of Sidon and Callimachus of Cyrene) wrote that the "Gates of Ishtar" and "Walls of Babylon" should still be considered one of the wonders.

THE ISHTAR GATE & DEITIES

The Ishtar Gate is named so, because it was dedicated to the Babylonian goddess Ishtar, although Nebuchadnezzar pays homage to other Babylonian deities through various animal representations. The animals represented on the gate are young bulls (*aurochs*), lions, and dragons (*sirrush*). These animals are symbolic representations of certain deities: lions are often associated with Ishtar, bulls with Adad, and dragons with Marduk. Respectively, Ishtar was a goddess of fertility, love, war, and sex, Adad was a weather god, and Marduk was the chief or national god of Babylon.

MATERIALS & CONSTRUCTION

The front of the gate is adorned with glazed bricks with alternating rows of dragons and bulls. The beasts are furnished in yellow and brown tiles, while the bricks surrounding them are blue. The blue enamelled tiles are thought to be of lapis lazuli, but there is some debate to this conjecture. The gates measured more than 38 feet (11.5 m) high with a vast antechamber on the southern side.

Through the gatehouse is the Processional Way, which is a brick-paved corridor over half a mile long with walls over 50 feet tall (15.2 m) on each side. The walls are adorned with over 120 sculptural lions, flowers, and enamelled yellow tiles. The Processional Way was used for the New Year's celebration, through which statues of the deities would parade down and the path paved with red and yellow stones (rows of red stone on the outer layers and a yellow row in-between). Each one of these stones has an inscription underneath: a small prayer from King Nebuchadnezzar to the chief god Marduk. It was this processional way that led to the temple of Marduk.

DEDICATION PLAQUE

On the Ishtar Gate, there is a dedication plaque written from Nebuchadnezzar's point of view that explains the gate's purpose and describes it in some detail.

Nebuchadnezzar, King of Babylon, the faithful prince appointed by the will of Marduk, the highest of princely princes, beloved of Nabu, of prudent counsel, who has learned to embrace wisdom, who fathomed their divine being and

reveres their majesty, the untiring governor, who always takes to heart the care of the cult of Esagila and Ezida and is constantly concerned with the well-being of Babylon and Borsippa, the wise, the humble, the caretaker of Esagila and Ezida, the firstborn son of Nabopolassar, the King of Babylon.

Both gate entrances of Imgur-Ellil and Nemetti-Ellil following the filling of the street from Babylon had become increasingly lower.

Therefore, I pulled down these gates and laid their foundations at the water table with asphalt and bricks and had them made of bricks with blue stone on which wonderful bulls and dragons were depicted.

I covered their roofs by laying majestic cedars length-wise over them. I hung doors of cedar adorned with bronze at all the gate openings.

I placed wild bulls and ferocious dragons in the gateways and thus adorned them with luxurious splendour so that people might gaze on them in wonder

I let the temple of Esiskursiskur (the highest festival house of Marduk, the Lord of the Gods a place of joy and celebration for the major and minor gods) be built firm like a mountain in the precinct of Babylon of asphalt and fired bricks.

EXCAVATION & RECONSTRUCTION

The Ishtar gate was excavated between 1902 to 1914 CE during which 45 feet (13.7 m) of the original foundation of the gate was discovered. The material excavated by Robert Koldewey was used in a reconstruction of the Ishtar Gate and the Processional Way. In 1930 CE, the reconstruction was finished at the **Pergamon** Museum in Berlin, Germany.

Due to size restrictions at the Pergamon Museum, the Ishtar Gate is neither complete nor its original size. The gate was originally a double gate, but the Pergamon Museum only utilizes the smaller, frontal part. The second gate is currently in storage. Originally, the gate had a door and roof made of cedar and bronze, which was not built for the reconstruction. A smaller reconstruction of the Ishtar Gate was built in Iraq under Saddam Hussein as the entrance to a museum. However, this reconstruction was never finished due to war.

There are several museums in the world that have received portions of the Ishtar Gate: the Istanbul **Archaeology** Museum, the Detroit Institute of Art, the Royal Ontario Museum, the Louvre, Munich's State Museum of **Egyptian Art**, New York's Metropolitan Museum of Art, the Oriental Institute of Chicago, and many others.”

Appendix 6: Guidelines from the Bavarian Monument Office

**Bavarian Law for the Protection and Preservation of
Monuments
(Monument Protection Law)**

from 25th June 1973 (BayRS 2242-1-K), last revised 27th July 2009 (GVBl 2009 p. 385, 390f.)

I. SCOPE

Article 1 Definitions

(1) Monuments are man-made things or parts thereof from a past epoch whose preservation, because of their historic, artistic, urban design, scientific or folkloristic significance, is in the interests of the general public.

(2) Built monuments are structures or parts thereof (including historic decorative details) from erected by Paragraph 4. Movable objects can also be historic decorative details if they are an integral part of an original interior design or a comparable historic refurbishing or redesign. Gardens are also considered to be built monuments insofar as they fulfill the requirements listed in Paragraph 1.

(3) Built monuments can also include more than one structure (historic district or Ensemble); every individual building in the Ensemble need not fulfil the requirements of Paragraph 1, if the townscape, square or streetscape as a whole is worthy of preservation.

(4) Archaeological monuments are movable and immovable monuments, which are or were in the earth and in general date from prehistorical or early historical times.

Article 2 Monument List

(1) For informational purposes-built monuments and archaeological monuments should be saltation with the local government. Entry can be suggested by the legally responsible parties and by the appropriate Local Heritage Conservator (/Heimatpfleger/). Entry in the list must be recorded in the building development plan. The list can be inspected by anyone.

(2) Movable monuments, insofar as they are not covered by Paragraph 1, can be entered in the list at the request of the legally responsible parties in especially important cases.

Article 3 Validity

(1) The provisions for protection in this law are valid for built monuments, for archaeological monuments and for all listed movable monuments.

(2) In the course of their public functions (above all within the framework of master planning) local governments must consider interests of monument protection and monument care, especially to the preservation of Ensembles.

n-State Conservation Office in country is made by the entered in a list (the Monument List). va past epoch which possess the significance listed in Paragraph 1, insofar as they are not co

Article 4 Preservation of Built Monuments

party must maintain, repair and appropriately treat their built monuments and protect them. If the party is not the direct occupant, then the provisions of Sentence 1 are also valid for the direct occupant, insofar as he has the possibility to act accordingly.

Written consent of the Highest Monument Protection Authority is necessary for decisions which are binding on the federal government or state governments. The Monument Protection Authority can carry out the measures or allow them to be carried out. The parties having legal responsibility for the real property can be obligated to allow the measures to be carried out. The costs of the measures must be borne by the persons named in Paragraph 1, insofar as they were or could have been obligated to carry out the measures according to Paragraph 2; in other cases, costs are borne by the Compensation Fund (Article 21, Paragraph 4).

(4) Treatments, which damage or endanger a built monument can be forbidden.

Article 5 Use of Built Monuments

Built monuments should be used for their original purpose, to the extent that this is possible. The party having legal responsibility over the use should strive for a use, which is similar, or equipment's historic fabric should be chosen. If various uses are possible, that use which has the least adverse effect on the built monument and its appurtenances should be chosen. The state, insofar as the provisions of Article 4 Paragraph 2 are fulfilled, the owner and those parties otherwise having legal responsibility over the use can be obligated to implement a certain type of use; insofar as they are not obligated to implement this use, they can be obligated to allow certain types of use.

Article 6 Measures on Built Monuments

(1) Whoever wishes to

1. Demolish, alter or relocate built monuments or
2. Demolish, alter, relocate or remove protected appurtenances from built monuments

must have permission. Permission is also required for anyone who wishes to erect, alter or remove a structure, if the alteration concerns a structure, which is for itself a built monument, or if this could affect the appearance of the Ensemble.

(2) Under the provisions of Paragraph 1 Sentence 1 No. 1 and 2, permission can be prohibited insofar as important reasons favour the unaltered preservation of the existing condition. Under a-y must appearance of one of the built monuments.

Whoever wishes to alter an Ensemble only-remove a structure in the vicinity of built monuments, if this could affect the condition. The local governments and other bodies should support owners and occupy-term preservation of the monuments. If this is not possible, a use which ensures the longer not used according to their original purpose, the owner or those otherwise having legal responsibility over the use (2). A ruling according to Paragraph 2 does not exist, the responsible Ministry and an enforceable

(3) If the condition of a built monument requires measures for maintenance, repair or protection, the owner or those otherwise having legal responsibility over the use can be obligated to allow measures to be carried out by others. The priority to their other responsibilities and obligations. Insofar as they cannot carry out these measures themselves, this can be reasonably demanded, giving due consideration, in whole or in part, insofar as a-

(2) The persons named in Paragraph 1 can be obligated to carry out certain preservation measures from danger. If the owner or another party having legal responsibility for real property disposes of real property for the disposition of real property (1) The owners and those otherwise having legal

responsibility. **BUILT MONUMENTS 2**

the provisions of Paragraph 1 Sentence 2, permission can be denied if the planned action would lead to an adverse effect on the character, the appearance or the artistic effect of a built monument and important reasons favor the unaltered preservation of the existing condition.

(3) If a building permit or in its place a building inspection consent or an inspection permit to dig off is required, than the [above-mentioned] permission is not required. If in the case of ing inspection consent is not required, but in accordance with Article 63 Paragraph 1 Sentence ing to this law includes the consent in particular cases according to Article 18 paragraph 2 BayBO and the variance according to Article 63 Paragraph 1 Sentence 1 BayBO.

(4) In case of decisions in accordance with Paragraph 1 through 3 the interests of disabled persons and persons with other mobility injuries must consider.

III. ARCHAEOLOGICAL MONUMENTS

Article 7 Excavation of Archaeological Monuments

(1) Permission is necessary for anyone wishing to excavate archaeological monuments on a property or to undertake excavation work on a property for other purposes, if he knows, or supposes, or circumstances support the assumption that archaeological monuments are located logical monument.

(2) Specific properties suspected of containing archaeological monuments can be designated tion Area, all work which could endanger archaeological monuments requires permission. tecton Areas must be designated in the land use plan.

(3) Paragraph 1 and Paragraph 2 do not apply to excavations which are undertaken or ordered by or with the participation of the State Conservation Office.

(4) Permission is required for anyone wishing to erect, alter or remove a structure which is in the vicinity of archaeological monuments which are wholly or in part recognizable above the earth's surface if this could affect the condition or appearance of one of these archaeological monuments. Article 6 Paragraph 2 Sentence 2 and Paragraph 3 are applicable accordingly.

(5) The owner of a property can be obligated to allow an excavation if the State Conservation Office has determined that the excavation is of particular public interest. The holder of the excavation permit must compensate the owner for damages which arise.

Article 8 Discovery of Archaeological Monuments

ly with the Local Monument Protection Authority or with the State Conservation Office. This obligation applies to the owner or the occupant of the property as well as to the contractor or ties releases the others from this obligation. If the finder was engaged as an employee on the ployer or project director.

m-work which led to the discovery, he is released from this obligation by reporting to his er-project director for the measures which led to the discovery. Registration by one of these pat-(1) Anyone finding an archaeological monument is obligated to register his discovery prompo-Article 6 Paragraph 2 Sentence 2 and Paragraph 3 are applicable accordingly. Excavation Prc-riacts. Within an Excavation Proteas Excavation Protection Areas through decrees by the disto-Permission can be refused, insofar as this is necessary for the protection of an archaethere. d-used by the capacity as a monument is required, the permission accorvariance caa 1 BayBO d a building permit or a built of the Bavarian Building Code (BayBO) Article 18 Paragraph 2 3

(2) Discovered objects and their sites must be left unaltered for one week after the date of attenuation of the work previously.

(3) Paragraphs 1 and 2 do not apply to work which is undertaken or ordered by or with the participation of the State Conservation Office.

(4) Owners, those having legal responsibility for the disposition of real property, and direct gated to allow the measures necessary for a professional salvage of the artefacts, as well as for archaeological monuments on the property.

Servation Office or to a Monument Protection Authority for safekeeping.

Article 9 Analysis of Findings

The owner of a movable archaeological monument, those having legal responsibility for it, fice for a limited time for scientific analysis and documentation.

IV. LISTED MOVABLE MONUMENTS

Article 10 Obligation to Secure Permission

(1) Permission is required for anyone wishing to destroy, alter or relocate a listed movable monument. Permission can be denied if this is necessary for the protection of the monument.

tion Office. The seller and the buyer are obligated to register the transaction.

V. PROCEDURAL REGULATIONS

Article 11 Monument Protection Authorities

(1) The Local Monument Protection Authorities are the county government offices. Local governments that gave assumed the functions of the Local Building Authority from the county ragraph 2 of the Municipal Code is applicable accordingly.

(2) The Upper Monument Protection Authorities are the district governments.

(3) The Highest Monument Protection Authority is the Bavarian State Ministry of Sciences, Research and the Arts.*

(4) Unless otherwise specified, the Local Monument Protection Authority is responsible for enforcement of this law. Under the provisions of Article 73 Paragraph 1 BayBO the Upper thorities

. u-Monument Protection Authorities is taking the place of the Local Monument Protection Aa-shall also assume the functions of the Local Monument Protection Authority. Article 115 Pa-(2) The sale of a listed movable monument must be

promptly reported to the State Conserve-o the State Conservation and the direct occupant can be required to hand over the object TN-(5) If danger of their loss

exists, discovered objects must be given promptly to the State -the clarification of the circumstances of the discovery and for the protection of further occupants of a

property on which archaeological monuments have been found can be obtained, unless the Local Monument Protection Authority clears the objects or allows

coregistr4

Ornaments, they are delegated functions.

Article 12 State Conservation Office

Monument protection and monument care. It is directly subordinate to the State Ministry. *

tion in the protection of monuments. Monument care also encompasses monument research,

1. participation in the enforcement of this law and other pertinent regulations, as provided in these regulations and others which have been promulgated;
2. issuance of guidelines for the care of monuments, in cooperation with local organizations;
3. preparation and continuation of the inventories and the monument lists;
4. conservation and restoration of monuments, insofar as their conservation and restoration is not carried out by other responsible state offices;

Monument protection and monument care;

6. Supervision of excavations, as well as the supervision and recording of the accumulated movable archaeological monuments;

tered by the state.

The State Ministry * can assign other relevant functions to the State Conservation Office.

kes remain unchanged.

Article 13 Local Heritage Conservators

(1) The Local Heritage Conservators advise and support the Monument Protection Authorities and the State Conservation Office in questions of monument care and monument protection. The Monument Protection Authorities must give the conservators ample time to comment on relevant cases within the scope of their duties.

(2) The Monument Protection Authorities and the State Conservation Office should avail themselves in appropriate cases of the support of local offices and private initiatives.

Article 14 State Monument Advisory Board

(1) The State Monument Advisory Board has the task of advising the state government and of participating in important issues concerning monument care. The State Monument Advisory Board must participate in the listing of a historic district (Ensemble). The members of the pointment for members is for the duration of the legislative period. The members perform ministry *, the State Ministries of the Interior (Highest Building Authority) and for Development and Environmental Problems as well as the State Conservation Office must be invited to all discussions by the State Monument Advisory Board.

(2) The State Monument Advisory Board consists of:

n-The State duties without pay. They choose a chairman from among their members. Paragraph 2b through l thereby from nominations by the authorities concerned. The term of aa-PMonument Advisory Board are appointed by the State Parliament, the members listed in a-ctions of the Bavarian Administration of State Palaces, Gardens and L(3) The existing funs-7. care of local museums and similar collections, insofar as these are not otherwise adminio-5. provision of professional advisory services and consultation reports in all aspects of mlar: u-compatible with them. It has the following responsibilities in particsservation Office and are n-as far as such projects are directly connected with the other responsibilities of the State Coa-Office involve the care of monuments and particip(2) The duties of the State Conservation o-(1) The State Conservation Office is the specialized state office for all issues concerning mv (5) The functions of the Monument Protection Authorities

are state functions; for local go5

- a) six members of the State Parliament,
- b) one representative of the Association of Bavarian Cities, and the Association of Bavarian Counties,
- c) one representative of the Association of Bavarian Districts,
- d) two representatives each from the Catholic Church and the Protestant-Lutheran Church in Bavaria,
- e) three representatives of private monument owners,
- f) one representative of the Bavarian Academy of Fine Arts,
- g) one representative each from the architectural community and the Bavarian Chapter of the German Academy for Urban Design and State Planning,
- h) one representative of the State Monument Advisory Board,
- i) one representative of the Bavarian Association of Farmers,
- k) two experts in the fields of art history and early and ancient history, to be proposed by the State Ministry, *
- l) up to five further members, to be proposed by the State Ministry.*

(3) Political groups in the State Parliament which otherwise do not have a member on the Board according to Paragraph 2a receive one seat.

(4) For clarification of specialized issues, the State Monument Advisory Board may appeal to experts, who serve in a non-voting capacity.

(5) The State Ministry * is authorized to establish regulations concerning the organization, the number of the members and provisions for the compensation of travel expenses.

Article 15 Procedures for Permission and Restitution

(1) An application for issuance of permission according to Articles 6, 7, and 10 Paragraph 1 and concerning obligations of the property owner according to Article 7 Paragraph 5 must be submitted in writing to the local government, which must submit its opinion promptly to the Local Monument Protection Authority. Articles 75 and 76 of the Bavarian Building Code are valid in cases involving Articles 6, 7 and 8 Paragraph 2.

(2) The Local Monument Protection Authority shall consult the State Conservation Office according to Paragraph 1 Sentence 3 of the Bavarian Building Code is applicable accordingly. according to Chapter II through IV of this law.

(3) If actions according to Articles 6, 7, 8 Paragraph 2 or Article 10 Paragraph 1 are carried out, the Local Monument Protection Authority can require restitution of the original condition, insofar as this is possible; for listed monuments and listed movable monuments can be required.

(4) Whoever unlawfully, deliberately or in a grossly negligent way destroys or damages a built monument, an archaeological monument or a listed movable monument is obligated, independently from the imposition of a fine, to make restitution for the damages he caused to their full extent.

u-possible; or the restoration in some other fashion of built monuments, archaeological monuments or movable monuments. If a monument is damaged without the required permission, the Bavarian Building Code is applicable accordingly for permissions according to Paragraph 2a) Article 6 Paragraph 5 before making a decision according to Sections II through IV of this law. Article 6 Paragraph 5 Sentence 1 and the management of the Monument Advisory Board, as well as the appointment of the members of the Board shall be as follows:
h) one representative of the Bavarian State Association for Conservation of the Local Heritage
b) one representative each from the Association of Bavarian Local Governments, the Association of Bavarian Cities, and the Association of Bavarian Counties

ing permit, building code consent or exploitation permit for a maximum of two years, if this is search on the monument and its surroundings).

Article 16 Rights of Access and Information

cerned, if this appears to be urgently necessary for the preservation of a built monument, an archaeological monument or a listed movable monument.

able monuments and other legally responsible parties are obligated to give the Monument Protection Authorities and the State Conservation Office all information necessary for the enforcement of this law.

Article 17 Exemption from Costs

No costs are imposed for official acts involving this law. If a permission according to Article 6 Paragraph 3 Sentence 2 includes the consent in particular cases according to Article 18 Paragraph 2 BayBO or the variance according to Article 63 Paragraph 1 Sentence 1 BayBO, cost are imposed for the consent or the variance according to the law of costs.

VI. EXPROPRIATION

Article 18 Admissibility of Expropriation

(1) If a danger to the condition or appearance of a built monument, archaeological monument or listed movable monument cannot otherwise effectively be averted, then expropriation is neffment, archaeological monument or listed movable monument is one of the statutory functions of the legal entity and if, giving due consideration to all the circumstances, preservation of the monument appears to be assured.

(2) Expropriation for the benefit of the state is also admissible for movable archaeological monuments, if their preservation is within the special interests of the public. Application for cases according to Sentence 1 can only be made if the complete salvage of the archaeological fore the time of application.

Article 19 Right of Pre-Emption

(1) The Free State of Bavaria has the right of pre-emption in the event of the sale of historic appurtenances which are protected as part of listed built monuments according to Article 1 Paragraph 2, and in the event of the sale of listed movable monuments. The right of pre-emption of the listed movable monuments should be made accessible to the public or should be nances or of listed movable monuments sells these to his/her spouse or to another person who is related directly or as an in-law, or in a side lineage up to the third degree. The right of pre-emption does not exist if th-preserved in their totality. The right of pre-emption can only be exercised if the common good justifies it, and especially if the appurte-monument has not been known to the State Conservation Office for longer than one year bu-term preservation of the built mon-it of a legal private entity is permissible if the longe-allowable, for the benefit of the state or another legal public entity. Expropriation for the bv-(2) Owners and occupants of built monuments, archaeological monuments and of listed mon-servation Office have the right to enter a property, even against the will of the persons con-the State Co(1) For the enforcement of this law, the Monument Protection Authorities and ery for the clarification of the interests of monument protection (in particular, for rnessad (5) The responsible office can defer a decision regarding an application for permission, buil7

emption for the purchase of appurtenances does not apply if these are being sold together with the built monument and are to remain within the built monument.

(2) The right of pre-emption can only be exercised by the State Conservation Office within three months of notification to the State Conservation Office of the sale contract. Sections 463 through 468 Paragraph 1, Section 469 Paragraph 1 and Section 471 of the Civil Law Code (BGB) are applicable. The right of pre-emption is nontransferable. It has precedence over all other rights of pre-emption, except those provided by federal law. With the acquisition of property through the exercise of the right of pre-emption, other contractual rights of pre-emption expire.

Article 20 Expropriation Measures

erty ownership (Article 14 Paragraph 2 of the German Constitution, Article 103 Paragraph 2 and Article 158 of the Constitution of the Free State of Bavaria), the person concerned is to be granted monetary compensation, according to the provisions of the Bavarian law concerning the obligation to compensate for expropriation. Tax advantages based on monument listing are in all cases to be deducted to the appropriate extent from the compensation.

(2) The county government establishes the amount of compensation, after application by the party concerned. The provisions of the Bavarian law concerning expropriation with obligatory compensation are valid accordingly for the establishment of the compensation.

(3) If, on the basis of a new application, a decision is handed down which is more favorable sponds to the disadvantage caused. Paragraph 2 is applicable accordingly. An overpayment must be returned, insofar as the person receiving the compensation still has profited.

Article 21 Burden of Compensation Expenses

ensation together. Claims for compensation are to be made to the Free State of Bavaria. The Compensation Fund repays the Free State of Bavaria for the compensation payments granted to the affected parties. The district government is responsible for asserting the repayment claim.

(2) The Highest Monument Protection Authority establishes and administers a Compensation Fund as a state special capital fund, without its own legal status valid as of 1st January of the year following the year in which this law goes into effect. Half of the annual contributions to the fund are to be supplied by the Free State of Bavaria and half by the local governments. In tence 3 can be established through legal regulations according to Paragraph 4 with the consent of the State Parliament; after the Bavarian Association of Cities and the Bavarian Association of Local Governments have been heard, the final obligation of the communities can be raised to up to 50 % of the amount required by the State in the previous year according to Paragraph 1 Sentence 2 in combination with Article 20 and according to Article 4 Paragraph 3, if themeans in the fund are not enough to cover the costs of the payments.

(3) The contribution of the individual communities to the total amount of the Compensation Fund according to Paragraph 2 is determined according to the relevant apportionment for the

n-. Contributions in a different amount from Segeneral this amounts to 5 million EURO eachm-State of Bavaria and its communities must carry the burden of co(1) In principle the Free e-t it corring to Paragraph 1, then in all cases the compensation must be decreased so thad-for the party receiving the expropriation than is the decision on the compensation sum accorp ffects exceeding the social constraints of pro(1) Insofar as the enforcement of this law has e8

ration Law).

ticularly procedures for payment and charges, through legal regulations in agreement with the State Ministries of Interior and Finance. It can be provided that the State Office for Statistics and Data Processing computes and establishes the contributions and that the charges are made to the local governments by means of a bill to the counties.

(5) If an expropriation due to an expropriation procedure favors a public corporation which is not a territorial authority or favors a private corporation, then the corporation must bear the compensation costs.

VII. FINANCING

Article 22 Financial Contributions

(1) Notwithstanding existing obligations, the Free State of Bavaria assists with the costs of get appropriations for the costs of monument protection and monument care respectively. The extent of financial participation depends on the importance and the urgency of the case and on the financial capabilities of the owner.

(2) The local governments participate to an appropriate extent in the costs of the measures named in Paragraph 1 within the framework of their financial capabilities.

VIII. ADMINISTRATIVE OFFENCES

Article 23

ately or negligently:

1. undertake actions according to Article 4 Paragraph 4, although these have been forbidden by enforceable orders;
2. carry out measures on a built monument without the necessary permit or taking its place the building code consent or the exploitation permit according to Article 6 Paragraph 1, Article 7 Paragraph 4 Sentence 1 or Article 10 Paragraph 1;
3. excavate archaeological monuments without the necessary permit according to Article 7 danger archaeological monuments in an Excavation Protection Area without the necessary permit according to Article 7 Paragraph 2;
4. do not promptly report required information according to Article 8 Paragraph 1 or Article 10 Paragraph 2;
5. do not leave unaltered discovered objects and sites, according to Article 8 Paragraph 2;

graph

(2) The prosecution of these offenses is subject to a five year statute of limitations.

IX. GENERAL PROVISIONS AND CONCLUDING PROVISIONS

Article 24 Limitation on Constitutional Rights

5. a-6. do not promptly fulfill the obligation to surrender objects according to Article 8 Parn-t work which could eParagraph 1 or undertake excavations for another purpose or carry our-(1) Fines of up to two hundred fifty thousand EURO can be levied on persons who delibed-restoration, preservation, stabilization, and excavation of monuments according to state bur-(4) The Highest Monument Protection Authority is authorized to determine the details, paa nning fiscal year (article 18 Paragraph 3, Article 21 Paragraph 3 of the Financial Compens9

The basis right of the immunity of one's residence (Article 13 of the German Constitution, Article 106 Paragraph 3 of the Constitution), of personal freedom (Article 2 Paragraph 1 of the German Constitution, Article 101 of the Constitution) and of property (Article 14 of the German Constitution, Article 103 of the Constitution) are restricted by this law.

Article 25 Issuance of Certifications for Tax Purposes

Certifications for the attainment of tax benefits are issued by the State Conservation Office subject to ulterior provisions.

Article 26 Ecclesiastical Monuments

(1) Article 10 Sections 3 and 4 of the Concord with the Holy See from 29th March 1924 and Articles 18 and 19 of the contracts between the Free State of Bavaria and the Protestant-Lutheran Church in Bavaria Right of the Rhine from 15th November 1924 remain unaltered.

(2) If decisions are to be made involving built or archaeological monuments or listed movable tantclared church-related concerns of the relevant church offices. The churches must be allowed to participate in procedures. If the Local and Upper Monument Protection Authorities do not accept the asserted interests of the church, the decision is to be made by the appropriate church superior authority in consultation with the Highest Monument Protection Authority. Concerning other acknowledged religious communities, which are legal public corporations, sentence 1 through 3 are applicable correspondingly.

Article 27 Changed Regulations

(no longer valid)

Article 28 Effective Date

(1) This law takes effect 1 October 1973. **

(2) (no longer valid)

Notes

tural Affairs

** Applies to the version from 25th June 1973

Key to the laws

BayRS = Revised Collection of Bavarian Laws;

GVBI = Table of Laws and Ordinances

I-* At the time the law was passed (1973): the Bavarian State Ministry of Education and Cue-Lutheran Church, the Monument Protection Authorities must consider the d- s monuments which directly serve devotional purposes of the Catholic Church or the Prote10

Appendix 7: A description of the Church St. Kastulus

Appendix: Description of the church

“The early building history of the church can testify two main building periods: the second one refers to a partial rebuild after some components had collapsed after a huge fire around 1159. In that time the Romanesque portal has been built. Under bishop Adalbert von Freising (1158-1184 AD) who is illustrated in the tympanum, the inauguration took place around 1180 place. Another fire around 1207 destroyed the castle of the Earl of Moosburg, which was standing next to the church. The church suffered from this fire, too, and some parts needed to be rebuilt. After the rebuilt of the church it was inaugurated in the year 1212 again. This re-erection of the church took place under bishop Otto II von Freising and Hartwig von Eichstätt.” ((Hildebrandt, 2005) taken from (Herkner, 2008))

“Today the church has a three-aisled nave, which was extended with a choir in the 15th century. This component is taller than the nave and brings more light into the inner church. The cloister, a few chapels and the lobby in front of the west portal were demolished in the early 19th century.” ((Hildebrandt, 2005) taken from (Herkner, 2008))

Conservation History:

- 09/09/1972, restorer Eberhard Worch, Wolbeck, measures proposed to BLfD⁵⁸. "(...) The stone based Pebble acetate / methyltriethoxysilane is solidified and preserved with local subsequent aid of synthetic resin (Akrylharzlösung) (...) finally again to Impregnate."
- 18/10/1972, Doerner Institute (Dr. Riederer) the substantive review four cost offers / proposals for action to LfD: (...) to propose for the portal of Castulus minster I recommend, therefore, to accept the offer of the Lord Worch or the firm Mayer. (...)
- 1973 consolidation work carried out by Messrs. Worch. (Hildebrandt, 2005) (Huber, P. BLfD, Email 07.08.2007)

⁵⁸ Bayerisches Landesdenkmalamt (monument office)

Appendix 8: Aachener Dom

A short description of the construction from the “Dombaumeister”

“Plan and construction shape of the Aachen cathedral testify the meaning changing in the course of the centuries and use of this church construction. In wide parts unscathed is the karolingische (Carolingian) construction, domed octagon. The parting of the dome – an octagonal cloister vault – lies at 31.40-m height, its span amounts to 14.45 m. The octagon is surrounded by a 2-storey, 16 angular contact and is provided with a mighty input front. In the west yoke of the high-level cathedral the medieval throne which is to be dated according to the latest investigations in the Carolingian time is put up. In the east the Gothic choral construction which is formed as nave hall construction with two yokes and a 9/14-choral end connects. This statically unique construction is dominated by the about 26 m high window roads. Five chapel constructions formed with irregular plans which are explained by the majority as double-storey arrangements in Gothic time lean upon the outer walls of the 16 corner.”

(Dombaumeisterev.de, n.d.)

XI. Bibliography

ADAMS, A. T. 2016. *Drawing for Understanding*, Historic England.

AG, E.-T. T. 2016. *Medientext: Ort und Geschichte* [Online]. Engelberg Tourismus. Available at: http://www.engelberg.ch/fileadmin/redakteur/Headerlink/Media/Pressetexte/engelberg_medien_pressetexte_ort_u_geschichte_130123_en_as.pdf [Accessed 2016].

AGRAWAL, N., CHOUKSEY, P. and TANDAN, S.R. 2016. Development of Virtual Infrastructure in Academic Premises for Better Utilization of Computing Resources. *International Journal for Research in Applied Science & Engineering Technology (IJRASET)*, 4, 340-345.

ANDREWS, D., Bedford, J., BLAKE, B., BRYAN, P., CROMWELL, T. and LEA, R. 2009. *Measured and Drawn, Technique and practice for the metric survey of historic buildings*, England, English Heritage. Anon, 2018. <https://math.tutorvista.com/geometry/indirect-measurement.html>. [online] Available at: <https://math.tutorvista.com/geometry/indirect-measurement.html> [Accessed Jan. 2018].

BEDFORD, J. 2017. *Photogrammetric Applications for Cultural Heritage. Guidance for Good Practice.*, Swindon, Historic England.

BELL, D. 1997. *Historic Scotland Guide to International Conservation Charters*, Edinburgh, Historic Scotland.

Bldf.bayern.de. n.d. *Landesamt*. [online] Available at: <http://www.blfd.bayern.de/landesamt/index.php> [Accessed 2014].

BSI 2013. *Guide to the Conservation of Historic Buildings*, BSI.

CAMERON, C. 2009. The Evolution of the Concept of Outstanding Universal Value. In: Stanley-Price, N. and King, J. (EDITORS) *Conserving the Authentic: Essays in Honour of Jukka Jokilehto*, ICCROM, 127 - 141. [Online]. Available at: http://www.iccrom.org/ifrcdn/pdf/ICCROM_ICCS10_JukkaFestchrift_en.pdf [Accessed September 2017].

CARTWRIGHT, M. 2013. *Naxos*. [online] Ancient History Encyclopedia. Available at: <https://www.ancient.eu/Naxos/> [Accessed 2015].

Cidoc-crm.org. n.d. *Home / CIDOC CRM*. [online] Available at: <http://www.cidoc-crm.org> [Accessed 32016].

CLARK, K. 1999. *Conservation Plans: A guide for the perplexed...*, English Heritage

CLARK, K. 2001. *Informed Conservation*, English Heritage.

CLARK, K. 2004. *Informed Conservation leaflet*. English Heritage.

CORR, S. E. A. 2011. *Competences for access to the conservation-restoration profession*, Brüssel, E.C.C.O.

COUNCIL, T. N. M. 1997/ 98. *Conservation Principles*.

Council of Europe 2005. *Framework Convention on the Value of Cultural Heritage for Society, Faro*

COX 1996. *Assessment and Recording - A practitioner's View*. In: MARKS, S. & FEILDEN, B. M. 1996. *Concerning buildings studies in honour of Sir Bernard Feilden*, Oxford etc., Architectural Press.

CRABBEN, J. 2012. *Model of the Ishtar Gate*. [online] Ancient History Encyclopedia. Available at: <http://www.ancient.eu/image/735/>. [Accessed 2015].

DENARD, H. 2009. *London Charter*, Kings College, London.

Denkmalpflege.lvr.de. n.d. *Aufgaben - LVR-Amt für Denkmalpflege im Rheinland*. [online] Available at: http://www.denkmalpflege.lvr.de/de/aufgaben/aufgaben_1.html [Accessed 2017].

DEPARTMENT FOR COMMUNITIES AND LOCAL GOVERNMENT 2012
National Planning Policy Framework

Dombaumeisterev.de. n.d. *Dom Aachen I Dombaumeister E.v.* [online] Available at: <http://dombaumeisterev.de/?dom=dom-zu-aachen> [Accessed 2015].

DOWSON, T. n.d. *The Ishtar Gate in the Pergamon Museum – Archaeology Travel*. [online] Archaeology Travel. Available at: <https://archaeology-travel.com/photo-album/ishtar-gate-in-the-pergamon-museum/> [Accessed 2015].

DRURY, P. A. M., A. 2008. *Conservation Principles, Policies and Guidance for the Sustainable Management of the Historic Environment*, English Heritage.

DRURY, P. 2012. *Conservation: An Evolving Concept*, Building Conservation Directory

- E.C.C.O. 2002. *Professional Guidelines I* [Online]. BE-1000 Bruxelles, Belgique: E.C.C.O.
- E.C.C.O. 2016/ 2017. *European Confederation of Conservator-Restorers Organisation* [Online]. Available at: <http://www.ecco-eu.org/about-ecco/mission-vision/> [Accessed September 2017].
- EPPICH, R. and CHABBI, A., eds. 2007. *Recording, Documentation and Information Management for the Conservation of Heritage Places: Illustrated Examples*. Los Angeles, CA: Getty Conservation Institute. [online] Available at: http://hdl.handle.net/10020/gci_pubs/recordim_vol2
- ENGLISH HERITAGE 2011. *3D Laser Scanning for Heritage*. 2nd ed. England: English Heritage.
- ERZBISTUM-MUENCHEN. 2013. Available at: <https://www.erzbistum-muenchen.de/Page004750.aspx> [Accessed 2013].
- Exactmetrology.com. n.d. *White Light Scanning I White Light Scanner*. [online] Available at: <http://www.exactmetrology.com/3d-scanning-technology/white-light-scanning> [Accessed 2016].
- FECKER, H. 1992. *Stuttgart Die Schlösser und Ihre Gärten*, Stuttgart, J.F. Steinkopf Verlag GmbH.
- FEILDEN, B. 1994. *Conservation of Historic Buildings*, Butterworth-Heinemann Ltd.
- FEILDEN, B. and JOKILEHTO, J. 1993. *Management Guidelines for World Cultural Heritage Sites*, ROME, ICCROM
- FOUNDATION, E. 2012. *Europeana* [Online]. Europeana Foundation. Available at: https://www.bundesarchiv.de/archivgut_online/laufende_projekte/europeana/ [Accessed 2016].
- FREISING, K. D. I. E. M. U. 2011. *Kultraum Kulturraum*, München, Hans-Jürgen Denmark & Norbert Jocher.
- GALIZIA, M. S., C. 2015. *3D VIRTUAL RECONSTRUCTION OF AN URBAN HISTORICAL SPACE: A CONSIDERATION ON THE METHOD*. Digital Heritage. Marseille.
- GARCIA, B. 2013. *Ishtar Gate* [Online]. Available at: http://www.ancient.eu/Ishtar_Gate/. [Accessed 2015].
- Geoportal.aachen.de. n.d. *Stadt Aachen – Geodatenportal*. [online] Available at: <https://geoportal.aachen.de/extern/> [Accessed 2017].

- GREENGRASS, M., HUGHES, L. (EDITOR) 2008. *The virtual representation of the past*, Ashgate Publishing Company.
- GRELLERT, M. S., H. 2010. Rekonstruktion ohne Befund? *Befund und Rekonstruktion. Mitteilungen der Deutschen Gesellschaft für Archäologie des Mittelalters und der Neuzeit*, 22, 292.
- GRUBEN, G.; OHNESORG, A. et al., 2002. *Naxos – Das Heiligtum von Gyroula bei Sangri*, *Antike Welt* 33, 2002 (H. 4) 387-406
- Gsk.ch. n.d. *INSA | Gesellschaft für Schweizerische Kunstgeschichte*. [online] Available at: <https://www.gsk.ch/de/insa.html> [Accessed 30.Sept. 2018].
- HERKNER, S. and MARR, B. 2008. *Das romanische Portal der Pfarrkirche St. Kastulus in Moosburg an der Isar; Untersuchung zur Farbfassungen*.
- HILDEBRANDT, M. M. A. 2005. Archivalische Bauforschung Archivrecherchen.
- HISTORIC ENGLAND 2016. *Definition* [Online]. Available: www.historicengland.org.uk [Accessed 2016].
- HISTORIC ENGLAND 2018. *3D Laser Scanning for Heritage: Advice and Guidance on the Use of Laser Scanning in Archaeology and Architecture*. Swindon. Historic England
- HISTORIC ENGLAND 2016. *Local Heritage Listing Historic England Advice Note 7* Historic England.
- HISTORIC ENGLAND 2017. *BIM for Heritage: Developing a Historic Building Information Model*, Swindon, Historic England.
- HISTORIC SCOTLAND 2000. *Conservation Plans: A Guide to the Preparation of Conservation Plans*, Edinburgh: Historic Scotland.
- HOPPE, S. A. S., G. 2012. *Historical objects and digital modelling: Current concepts, strategies, standards*. Electronic Media and Visual Arts (EVA) Conference. Berlin.
- HORN, F. 2003. *Digital imaging a tool of preventive conservation*. Diploma, Siegl Verlag.
- HUBEL, A. 2011. *Denkmalpflege*, Stuttgart, Reclams Universal-Bibliothek.
- HUTCHINGS, J AND CORR, S. 2011. *A framework for access to the conservation–restoration profession via the mapping of its specialist competencies*.

ICOMOS 1964. *Venice Charter*, Italy, International Council on Monuments and Sites

ICOMOS 1979, 1981, 1988 revised 2013. *The Burra Charter*, Great Britain, International Council on Monuments and Sites UK.

ICOMOS 1983. *Appleton Charter for the Protection and Enhancement of the Built Environment*.

ICOMOS 1990. *The Charter of Lausanne - Charter for the Protection and Management of the Archaeological Heritage* (1990)

ICOMOS 1994. THE NARA DOCUMENT ON AUTHENTICITY.

ICOMOS 1996. *Principles for the Recording of Monuments, Groups of Buildings and Sites*, Sofia

ICOMOS 1999. *International Cultural Tourism Charter. Principles And Guidelines For Managing Tourism At Places Of Cultural And Heritage Significance*. International Cultural Tourism Committee.

ICOMOS New Zealand Charter revised 2010. *ICOMOS New Zealand Charter for the Conservation of Places of Cultural Heritage Value* Auckland, ICOMOS New Zealand (Inc.).

ICOMOS 2012. *Monumenta I - Internationale Grundsätze und Richtlinien der Denkmalpflege*, München, Fraunhofer IRB Verlag.

ICOMOS 2014. *Nara 20+ - ON HERITAGE PRACTICES, CULTURAL VALUES, AND THE CONCEPT OF AUTHENTICITY*, Japan

INTERGOVERNMENTAL COMMITTEE FOR THE PROTECTION OF THE WORLD, C., NATURAL, H., UNESCO & WORLD HERITAGE, C. 2016. *Operational guidelines for the implementation of the World Heritage Convention*, Paris, Unesco World Heritage Centre.

International Council of Museums (ICOM) 2013. "The CIDOC Conceptual Reference Model," 2013 [online] Available at: <http://www.cidoc-crm.org/> last [Accessed 01.Jan. 2018].

ip51.icomos.org. n.d. [online] Available at: http://ip51.icomos.org/~fleblanc/projects/19831992_HC/brochures%20%20publications/p_hc_1980_pub_definitionse.pdf [Accessed 2016].

JOKILETHO, J. 2006. *Considerations on authenticity and integrity in world heritage context*. City & Time 2 (1): 1. [online] Available at: URL:<http://www.ct.ceci-br.org>

KERR, J.S. 1982. *The Conservation Plan: A Guide to the Preparation of Conservation Plans for Places of European Cultural Significance*, The National Trust of Australia, Sydney

KERR, J.S. 2013. *Conservation Plan*, Australia ICOMOS

Kulturgutschutz-deutschland.de. n.d. *Kulturgutschutz – Denkmalschutz*. [online] Available at: http://www.kulturgutschutz-deutschland.de/DE/AllesZumKulturgutschutz/Rechtsgrundlagen/NationalesRecht/Denkmalschutz/denkmalschutz_node.html [Accessed 2016].

Kulttuurisampo.fi. n.d. *Kulttuurisampo - suomalainen kulttuuri semanttisessa web 2.0:ssa*. [online] Available at: <http://www.kulttuurisampo.fi/?lang=en>. [Accessed 2016].

LANE, R. 2016. *Understanding Historic Buildings*, Historic England.

LETELLIER, R., SCHMID, W. and LeBLANC, F. 2007. *Recording, Documentation, and Information Management for the Conservation of Heritage Places: Guiding Principles*. Los Angeles, CA: Getty Conservation Institute. http://hdl.handle.net/10020/gci_pubs/recordim

LOPEZ-MENCHERO, V. M. G., ALFREDO 2011. *THE PRINCIPLES OF THE SEVILLE CHARTER*.

LVR 2012. *Die karolingische Pfalzkapelle in Aachen*, Wernersche Verlagsgesellschaft mbH, Worms, Dr. Andrea Pufke, LVR Amt für Denkmalpflege im Rheinland.

MAAS, W. 2013. *Aachener Dom*, Regensburg, Schnell & Steiner Verlag.

MARKS, S. & FEILDEN, B. M. 1996. *Concerning buildings studies in honour of Sir Bernard Feilden*, Oxford etc., Architectural Press.

MARTIN, B. 1998. *Information Liberation*, London, Freedom Press.

MATTHIAS LINK, F. 2014. *Digital Archaeology I 3D-Stills*. [online] Digital-archaeology.com Available at: http://www.digital-archaeology.com/index.php?nav_id=7 [Accessed 2015].

MENUGE, A. 2006. *Understanding Historic Buildings: A Guide to Good Recording Practice*. English Heritage.

- MESSEMER, H., 2016: *The Beginnings of Digital Visualization of Historical Architecture in the Academic Field*, in: Stephan Hoppe and Stefan Breittling (eds.) with the assistance of Heike Messemer: *Virtual Palaces, Part II. Lost Palaces and their Afterlife. Virtual Reconstruction between Science and Media*, München 2016, pp. 21-54 (= PALATIUM e-Publications, vol. 3).
- Ministerium des Inneren des Landes Nordrhein-Westfalen, R. 1980. *Gesetze und Verordnungen I Landesrecht NRW*. [online] Recht.nrw.de. Available at: https://recht.nrw.de/lmi/owa/br_text_anzeigen?v_id=5720031106092634017 [Accessed 2016].
- MONUMENTS, I. C. O. & SITES 1990. *Guide to Recording Historic Building*, Butterworth Architecture.
- MÜNSTER, C. n.d. Dehio – Das Handbuch [online] Dehio.org. Available at: <http://www.dehio.org/handbuch/index.html> [Accessed 2015].
- ODERMATT, W., 2008. *Dokumentation Hotel Engel*
- OHNESORG, A. 2005 *Naxian and Parian Architecture, General features and new discoveries*, in: M. Yeroulanou – M. Stamatopoulou (Hrsg.), *Architecture and Archaeology in the Cyclades*. Papers in honour of J. J. Coulton. BAR Internat. Ser. 1455 (2005) 140 fig. 4
- Packbierpeter.de. n.d. [online] Available at: <http://www.packbierpeter.de/joomla/images/pdf/acpfalz.pdf> [Accessed 2017].
- PANTALONY, R.E. 2013 *WIPO Guide on Managing Intellectual Property for Museums*, World Intellectual Property Organization (WIPO), CH
- PAUWELS, P. 2014a. Interpreting metadata and ontologies of virtual heritage artefacts
- PAUWELS, P. D. M., DANILO; DE MEYER, RONALD 2014b. Integrating building information modelling and semantic web technologies for the management of built heritage information.
- RICHMOND, A. & BRACKER, A. L. 2009. *Conservation: principles, dilemmas and uncomfortable truths*, Oxford, Butterworth-Heinemann in association with the Victoria and Albert Museum London.
- RISTOW, S. 2015. Von Aquileia bis Aachen, Deutung und Rekonstruktion, Erfassung und Beurteilung von Befunden aus Spätantike und Frühmittelalter. *NON SOLUM...SED ETIAM. Festschrift für Thomas Fischer zum 65. Geburtstag*. Rahden/ Westfl.: Heinrich, P.; Miks, Ch.; Obmann, J.; Wieland, M.

- RUGGERI, A. 2015. *The Great Gate of Ishtar: A door to wonder*.
[online] Bbc.com. Available at: <http://www.bbc.com/culture/story/20150302-ancient-babylons-greatest-wonder> [Accessed 2016].
- SHARP, J., PETERS, J., HOWARD, K. (2002). *The Management of a Student Research Project*. London: Routledge.
- STAATSKANZLEI, B. 25.06.1973. *Bayern.Recht* [Online]. Available at:
<http://www.gesetze-bayern.de/Content/Document/BayDSchG> [Accessed 2014].
- STANCO, F., BATTIATO, S. and GALLO, G. 2011. *Digital Imaging for Cultural Heritage Preservation: Analysis, Restoration, and Reconstruction of Ancient Artworks*, CRC Press, Inc.
- STANLEY-PROCE, N. and KING, J. 2009. *Conserving the authentic essays in honour of Jukka Jokilehto*, Rome, ICCROM.
- STYLIANIDIS, E. and REMONDINO, F. 2016. *3D recording, documentation and management of cultural heritage*, Caithness, Scotland, Whittles Publishing.
- THALLER, M. (2008). *Part III The Virtual Representation of Space and Time in the chapter: Which? What? When? On the Virtual Representation of Space and Time*. In: Greengrass, M. Hughes, L. (editor) 2008. *The virtual representation of the past*, Ashgate Publishing Company
- TAUSCH, O. (2013). [image] Available at:
<https://commons.wikimedia.org/w/index.php?curid=31523319>
[Accessed 2018].
- Teanecklaserdentist.com n.d. [online] Available at:
<http://www.teanecklaserdentist.com/assets/docs/LaserDefinitions.pdf>
[Accessed 20 Jan. 2018].
- The Artstor Blog. 2014. *From Babylon to Berlin: The rebirth of the Ishtar Gate*.
[online] Available at:
<https://artstor.wordpress.com/2014/0327the-rebirth-of-the-ishtar-gate/>
[Accessed 2015].
- UNESCO. 1978. *Germany Aachen Cathedral* [Online]. Available at:
<http://whc.unesco.org/archive/periodicreporting/EUR/cycle01/section2/3-summary.pdf> [Accessed 2016].
- UNESCO. 1992-2018. *Aachen Cathedral*. [online] Whc.unesco.org. Available at:
<http://whc.unesco.org/en/list/3/> [Accessed 2016].

- UNESCO. 2016. *Promotion and Use of Multilingualism and Universal Access to Cyberspace* [Online]. Available at: <http://www.unesco.org/new/en/communication-and-information/about-us/how-we-work/strategy-and-programme/promotion-and-use-of-multilingualism-and-universal-access-to-cyberspace/> [Accessed 2016].
- URQUHART, D. 2007. *Conversion of Traditional Buildings - Application of the Scottish Building Standards*, Edinburgh, Historic Scotland C Crown copyright.
- VERMESSUNGSDATEN, B. 2016. *Historische Karten* [Online]. Available at: https://geoportal.bayern.de/bayernatlas/?X=5368920.29&Y=4494652.63&zoom=11&lang=de&topic=ba&bgLayer=historisch&catalogNodes=122&layers=KML%7C%7Chttp:%2F%2Fwww.geodaten.bayern.de%2Ffreizeitwege%2FAmmer-Amper-Radweg_Oberammergau-Moosburg_a_d_Isar_Bayernnetz_fuer_Radler.gpx%7C%7Ctrue [Accessed 2015].
- WALFORD, A. 2007. *Photogrammetry* [Online]. Available at: www.photogrammetry.com [Accessed 2016].
- WENDLER, E. 2008. *Moosburg, St. Kastulus Romanisches Westportal - Naturwissenschaftliche Begleituntersuchungen zur Restaurierung*.
- WEYER, A., et al (Ed.), 2015, *Ewa Glos European Illustrated Glossary of Conservation Terms for Wall Paintings and Architectural Surfaces*, Petersberg
- Whc.unesco.org. 2012. [online] Available at: <http://whc.unesco.org/archive/opguide12-en.pdf> [Accessed 2017].
- WOOD, J. 1996. *Record Making and the Historic Environment* [Online]. Building Conservation Directory. Available at: www.buildingconservation.com [Accessed 31.10.2017].
- WORTHING D. & BOND, S. 2017. *Managing Built Heritage: The Role of Cultural Significance*, Blackwell Publishing
- W3.org.2015. *Semantic Web – W3C*. [online] Available at: <https://www.w3.org/standards/semanticweb/> [Accessed 2016].
- ZABERN, P. (Hsg.) 2002. *Antike Welt - Zeitschrift für Archäologie u.Kulturgeschichte* 33. Jahrgang 2002